

FEATURES

Full-Featured Evaluation Board for the AD7798
Stand alone USB Interface
Various Linking Options
PC Software for Control of AD7798

INTRODUCTION

This Technical Note describes the evaluation board for the AD7798 which is a Low Power, 16-Bit Sigma Delta ADC. The AD7798 is a complete analog front end for low frequency measurement applications. It contains three differential inputs and includes a low noise instrumentation amplifier, reference detect and a low side power switch. The update rate can be varied from 4.17 Hz to 500 Hz. It also has an on-board clock, eliminating the need for an external clock. It employs a sigma-delta conversion technique to realize up to 16 bits of no missing codes performance. The input signal is applied to an analog modulator. The modulator output is processed by an on-chip digital filter. The analog input channel of the AD7798 accepts analog input signals of $\pm V_{REF}/Gain$, with Gain equal to 1 to 128. With a gain of 64 and the update rate programmed to 16.7 Hz, the rms noise is 65 nV. Simultaneous 50 Hz/ 60 Hz rejection is available at this data update rate also.

Full data on the AD7798 is available in the AD7798 datasheet available from Analog Devices and should be consulted in conjunction with this Technical Note when using the evaluation board.

The evaluation board interfaces to the USB port of an IBM compatible PC. Software is available with the evaluation board which allows the user to easily communicate with the AD7798. **N.B.!! The AD7798 Evaluation Board Software should be installed BEFORE connecting the AD7798 Evaluation board to the PC.**

Other components on the AD7798 Evaluation Board include the ADP3303 which is a high precision, low power, 3.3V output, voltage regulator, which is used to power the USB/SPI interface .

OPERATING THE AD7798 EVALUATION BOARD Power Supplies

The board is powered via the 5V supply from the USB connector, J1. This 5V supply may be used to power the AD7798 directly or a 3.3V Regulated voltage from the on board ADP3303, high precision, low power, 3.3V output, voltage regulator may also be used. Alternatively, the AD7798 may be powered using an external 3V or 5V power supply via J3.

FUNCTIONAL BLOCK DIAGRAM

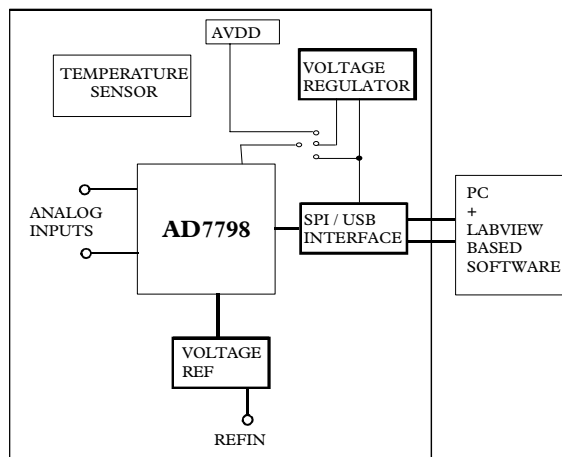

Figure 1. Functional Block Diagram

Rev. Pr A

Information furnished by Analog Devices is believed to be accurate and reliable. However, no responsibility is assumed by Analog Devices for its use, nor for any infringements of patents or other rights of third parties that may result from its use. Specifications subject to change without notice. No license is granted by implication or otherwise under any patent or patent rights of Analog Devices. Trademarks and registered trademarks are the property of their respective companies.

There are ten link options which must be set for the required operating setup before using the evaluation board. The functions of these link options are outlined below.

Table 1. Evaluation Board Link Settings

Link	Default	Description
LK1, LK2	In	These links are used to connect the AIN1(+) and AIN1(-) inputs to a reference voltage which equals $AV_{DD}/2$. With this configuration, a noise analysis can be performed. With these links removed, an external voltage may be applied to AIN1 using the SMB connectors.
LK3, LK4, LK5, LK6	Out	These links are used to connect the on board temperature demonstration circuit to the ADC, and must all be in place when attempting to measure ambient temperature. When LK3 and LK4 are inserted, the $1K\Omega$ thermistor is connected to AIN2. With LK5 and LK6 in place, a $5K\Omega$ precision resistor is used to generate the reference. This results in a ratiometric configuration.
LK7, LK8	In	A resistor divider network generates a voltage equal to $AV_{DD}/2$ which can be used as the reference for the AD7798. With LK7 and LK8 in place, $AV_{DD}/2$ is connected to REFIN(+) and REFIN(-) is connected to GND. To use another reference source, remove LK7 and LK8.
LK9	B	LK9 is used to select the power source for AV_{DD} on the AD7798. LK9 in position A selects an external power supply, supplied via J3. LK9 in position B selects the 3.3V regulated output from the onboard ADP3303 voltage regulator. LK9 in position C selects the 5V supply from the USB connector, J1.
LK10	In	LK10 is used to test the on chip low side power switch. With LK10 in place, enabling the low-side power switch in software by setting a bit in the configuration register turns on the LED, D2. Clearing this bit turns off the LED.

SET-UP CONDITIONS

Care should be taken before applying power and signals to the evaluation board to ensure that all link positions are as per the required operating mode. Table 1 shows the position in which all the links are set when the evaluation board is sent out.

Table 2: Initial Link and Switch Positions

Link No.	Position	Function
LK1 - LK2	In	AIN1(+) and AIN1(-) are shorted to the reference voltage
LK3 - LK6	Out	The demonstration circuit is disconnected from the AD7798
LK7 - LK8	In	The reference voltage is set to 1.65V ($3.3V/2$)
LK9	B	The 3.3V supply is used as AV_{DD} for the AD7798.
LK10	In	LED D2 is connected to the Low Side Power Switch of the AD7798

EVALUATION BOARD INTERFACING

Interfacing to the evaluation board is via a standard USB Connector, J1. J1 is used to connect the evaluation board to the USB port of a PC. A standard USB connector cable is included with the AD7798 evaluation board to allow the evaluation board to interface with the PC's USB port. As the board is powered via the USB connector, there is no need for an external power supply, although one may be connected if preferred via J3.

Communication between the AD7798 and the PC is over the USB/SPI interface. The onboard USB controller (U2) controls this communication. Remember, the AD7798 Evaluation Board Software should be installed (using the supplied AD7798 Evaluation Board CD ROM) BEFORE connecting the board to the PC.

After the AD7798 Evaluation Board Software has been installed, connect the board to the PC via J1 on the AD7798 Evaluation Board and the USB port on the PC using the supplied USB connector cable. The PC will automatically find the new USB device and will identify it as: AD7798 Evaluation Board. Follow the onscreen instructions that appear automatically. During the installation process if the following window appears:

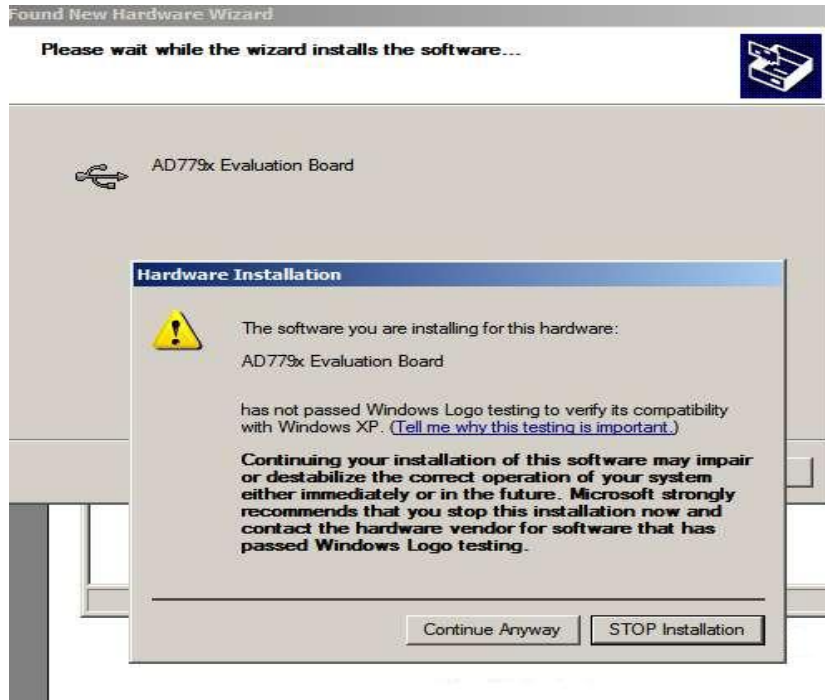

Hit Continue Anyway in order to successfully complete the installation of the AD7798 Evaluation Board.

SOCKETS

There are five sockets relevant to the operation of the AD7798 on this evaluation board. The functions of these sockets are outlined in Table 3.

Table 3. Socket Functions

Socket	Function
AIN1+	Sub-Miniature BNC (SMB) Connector. The analog input signal for the AIN1(+) input of the AD7798 is applied to this socket.
AIN1-	Sub-Miniature BNC (SMB) Connector. The analog input signal for the AIN1(-) input of the AD7798 is applied to this socket.
REFIN+	Sub-Miniature BNC (SMB) Connector. This socket is used in conjunction with REFIN(-) to apply an external reference to the AD7798. The voltage for the REFIN(+) input of the AD7798 is applied to this socket.
REFIN-	Sub-Miniature BNC (SMB) Connector. This socket is used in conjunction with REFIN(+) to apply an external reference to the AD7798. The voltage for the REFIN(-) input of the AD7798 is applied to this socket.
J2	34 Pin (2x16) pin Straight Header. This Socket is used in conjunction with the prototype area to interface any signal to the AD7798. It is specifically designed as a socket for a 34 pin header.

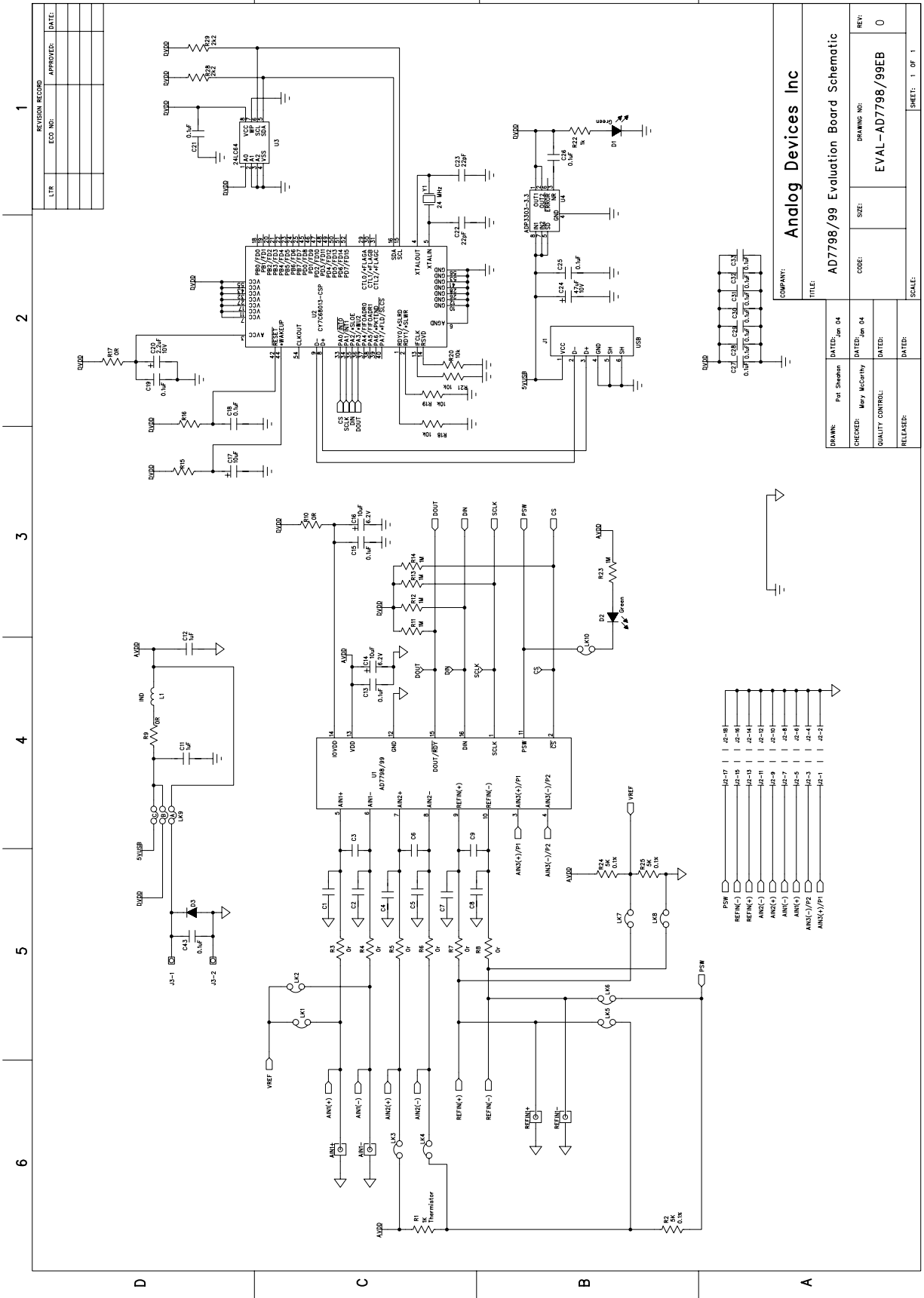

REVISION RECORD		APPROVED:	DATE:
LTR	ECO NO:		

DRAWN: Pat Sheehan		DATE: Jun 04	COMPANY: Analog Devices Inc	
CHECKED: Mary McConthy		DATE: Jun 04	TITLE: AD7798/99 Evaluation Board Schematic	
QUALITY CONTROL:		DATE:	CODE:	SIZE:
RELEASE:		DATE:	SCALE:	REV: 0
		DATE:	DRAWING NO: EVAL-AD7798/99EB	
		DATE:	SHEET: 1 OF 1	

[查询"EVAL-AD7798EB"供应商](#)

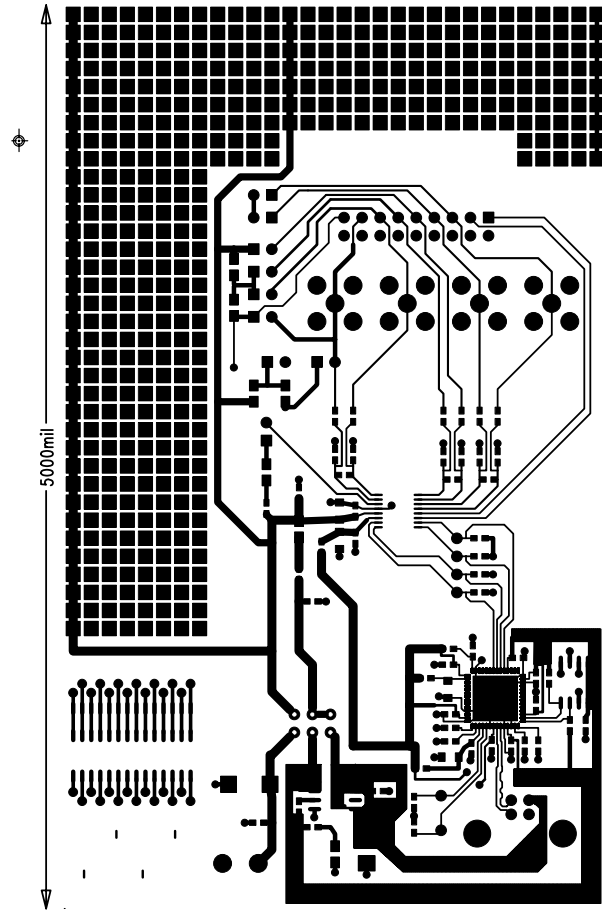

AD7798/99EB Rev. A (Component Side View) Component Side

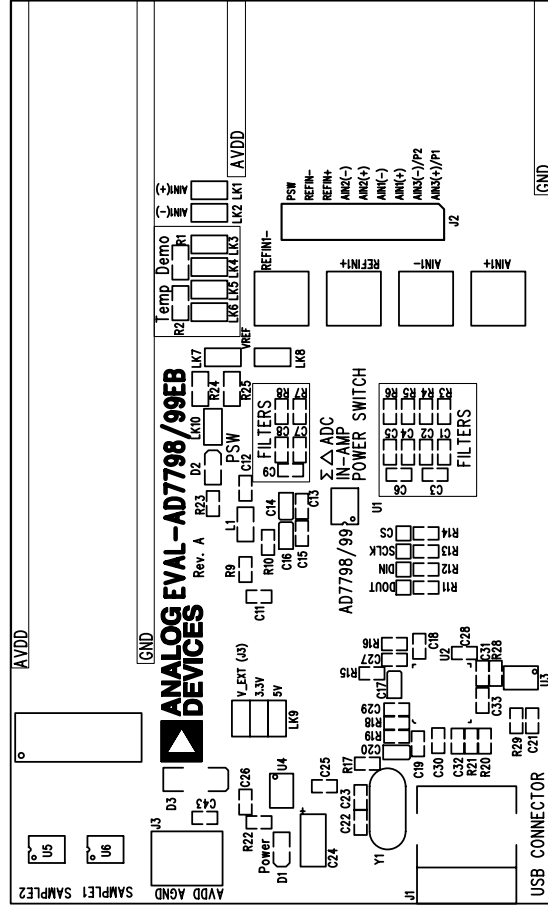

Eval-AD7798/99EB Rev. A (Component Side View)

Silkscreen



