

PRELIMINARY DATA

FEATURES

- 16-bit resolution
- 10MHz sampling rate
- Functionally complete
- No missing codes over full military temperature range
- Edge-triggered
- $\pm 5V$, $\pm 12V$ or $\pm 15V$ supplies, 1.5 Watts
- Small, 40-pin, ceramic TDIP
- 82dB SNR, $-86dB$ THD
- Ideal for both time and frequency-domain applications

GENERAL DESCRIPTION

The ADS-939 is a 16-bit, 10MHz sampling A/D converter. This device accurately samples full-scale input signals up to Nyquist frequencies with no missing codes. The dynamic performance of the ADS-939 has been optimized to achieve a signal-to-noise ratio (SNR) of 82dB and a total harmonic distortion (THD) of $-86dB$.

Packaged in a 40-pin TDIP, the functionally complete ADS-939 contains a fast-settling sample-hold amplifier, a subranging (two-pass) A/D converter, an internal reference, timing/control logic, and error-correction circuitry. Digital input and output levels are TTL. The ADS-939 only requires the rising edge of the start convert pulse to operate.

Requiring $\pm 5V$ supplies and either $\pm 12V$ or $\pm 15V$ supplies the ADS-939 dissipates 3.0 Watts. The device is offered with a bipolar ($\pm 2.75V$) or a unipolar (0 to $-5.5V$) analog input range. Models are available for use in either commercial (0 to $+70^\circ C$) or military (-55 to $+125^\circ C$) operating temperature ranges. A proprietary, auto-calibrating, error-correcting circuit enables the device to achieve specified performance over the full military temperature range. Typical applications include medical imaging, radar, sonar, communications and instrumentation.

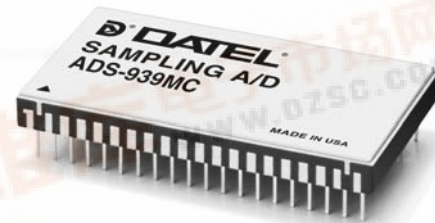

INPUT/OUTPUT CONNECTIONS

PIN	FUNCTION	PIN	FUNCTION
1	+3.2V REF. OUT	40	+12V/+15V
2	UNIPOLAR	39	-12V/-15V
3	ANALOG INPUT	38	+5V ANALOG SUPPLY
4	ANALOG GROUND	37	-5V SUPPLY
5	OFFSET ADJUST	36	ANALOG GROUND
6	GAIN ADJUST	35	COMP. BITS
7	DIGITAL GROUND	34	OUTPUT ENABLE
8	NC	33	OVERFLOW
9	NC	32	EOC
10	NC	31	+5V DIGITAL SUPPLY
11	NC	30	DIGITAL GROUND
12	START CONVERT	29	BIT 1 (MSB)
13	BIT 16 (LSB)	28	BIT 1 (MSB)
14	BIT 15	27	BIT 2
15	BIT 14	26	BIT 3
16	BIT 13	25	BIT 4
17	BIT 12	24	BIT 5
18	BIT 11	23	BIT 6
19	BIT 10	22	BIT 7
20	BIT 9	21	BIT 8

POWER AND GROUNDING	
+5V ANALOG SUPPLY	38
+5V DIGITAL SUPPLY	31
-5V SUPPLY	37
ANALOG GROUND	4, 36
DIGITAL GROUND	7, 30
-12/-15V ANALOG SUPPLY	39
+12/+15V ANALOG SUPPLY	40

POWER AND GROUNDING	
+5V ANALOG SUPPLY	38
+5V DIGITAL SUPPLY	31
-5V SUPPLY	37
ANALOG GROUND	2, 4, 36
DIGITAL GROUND	7, 30
NO CONNECTION	39, 40

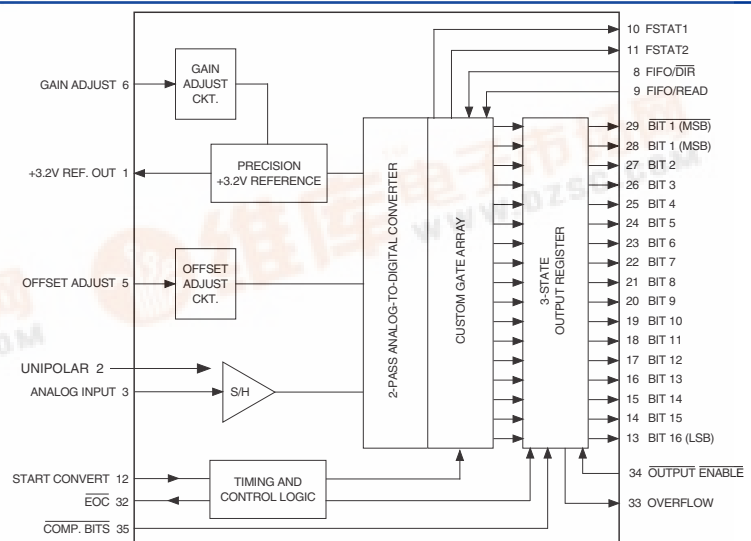

Figure 1. ADS-939 Functional Block Diagram



For full details go to
www.murata-ps.com/rohs

查询"ADS-939MM"供应商

16-Bit, 10MHz Sampling A/D Converters

ABSOLUTE MAXIMUM RATINGS

PARAMETERS	LIMITS	UNITS
+5V Supply (Pins 31, 38)	0 to +6	Volts
-5V Supply (Pin 37)	0 to -6	Volts
+12V/+15V Supply (pin 40)	0 to +16V	Volts
-12V/-15V Supply (pin 39)	0 to +16V	Volts
Digital Inputs (Pins 8, 9, 12, 34, 35)	-0.3 to +VDD +0.3	Volts
Analog Input (Pin 3)	±5	Volts
Lead Temperature (10 seconds)	+300	°C

PHYSICAL/ENVIRONMENTAL

PARAMETERS	MIN.	TYP.	MAX.	UNITS
Operating Temp. Range, Case	0	—	+70	°C
	-55	—	+125	°C
Thermal Impedance	—	4	—	°C/Watt
	—	18	—	°C/Watt
Storage Temperature Range	-65	—	+150	°C
Package Type	40-pin, metal-sealed, ceramic TDIP			
Weight	0.56 ounces (16 grams)			

FUNCTIONAL SPECIFICATIONS

(TA = +25°C, ±VCC = ±12/15V, +VDD = ±5V, 10MHz sampling rate, and a minimum 3 minute warm-up ① unless otherwise specified.)

ANALOG INPUT	+25°C			0 to +70°C			-55 to +125°C			UNITS
	MIN.	TYP.	MAX.	MIN.	TYP.	MAX.	MIN.	TYP.	MAX.	
Input Voltage Range										
Unipolar	—	0 to -5.5V	—	—	0 to -5.5V	—	—	0 to -5.5V	—	Volts
Bipolar	—	±2.75	—	—	±2.75	—	—	±2.75	—	Volts
Input Resistance (Pin 3)	—	400	—	—	400	—	—	400	—	Ω
(Pin 2)	—	480	—	—	480	—	—	480	—	Ω
Input Capacitance	—	10	15	—	10	15	—	10	15	pF
DIGITAL INPUTS										
Logic Levels										
Logic "1"	+2.0	—	—	+2.0	—	—	+2.0	—	—	Volts
Logic "0"	—	—	+0.8	—	—	+0.8	—	—	+0.8	Volts
Logic Loading "1"	—	—	+20	—	—	+20	—	—	+20	μA
Logic Loading "0" ②	—	—	-20	—	—	-20	—	—	-20	μA
Start Convert Positive Pulse Width ③	20	50	—	20	50	—	20	50	—	ns
STATIC PERFORMANCE										
Resolution	—	16	—	—	16	—	—	16	—	Bits
Integral Nonlinearity	—	±1	—	—	±1.5	—	—	±2	—	LSB
Differential Nonlinearity (fin = 10kHz)	-0.95	±0.5	+1.0	-0.95	±0.5	+1.0	-0.95	±0.5	+1.5	LSB
Full Scale Absolute Accuracy	—	±0.15	±0.3	—	±0.3	±0.5	—	±0.5	±0.8	%FSR
Bipolar Zero Error (Tech Note 2)	—	±0.1	±0.2	—	±0.2	±0.4	—	±0.4	±0.6	%FSR
Bipolar Offset Error (Tech Note 2)	—	±0.1	±0.2	—	±0.2	±0.4	—	±0.4	±0.6	%FSR
Gain Error (Tech Note 2)	—	±0.15	±0.3	—	±0.3	±0.5	—	±0.5	±0.8	%
No Missing Codes (fin = 10kHz)	16	—	—	16	—	—	16	—	—	Bits
DYNAMIC PERFORMANCE										
Peak Harmonics (-3dB)										
dc to 500kHz	—	-87	TBD	—	-87	TBD	—	-82	TBD	dB
500kHz to 5MHz	—	-82	TBD	—	-82	TBD	—	-78	TBD	dB
Total Harmonic Distortion (-3dB)										
dc to 500kHz	—	-86	TBD	—	-86	TBD	—	-81	TBD	dB
500kHz to 5MHz	—	-81	TBD	—	-81	TBD	—	-77	TBD	dB
Signal-to-Noise Ratio										
(w/o distortion, -3dB)										
dc to 500kHz	TBD	86	—	TBD	86	—	TBD	80	—	dB
500kHz to 5MHz	TBD	85	—	TBD	85	—	TBD	80	—	dB
Signal-to-Noise Ratio ④										
(& distortion, -3dB)										
dc to 500kHz	TBD	82	—	TBD	82	—	TBD	78	—	dB
500kHz to 5MHz	TBD	81	—	TBD	81	—	TBD	75	—	dB
Noise	—	80	—	—	80	—	—	80	—	μVrms
Two-Tone Intermodulation										
Distortion (fin = 200kHz, 240kHz, fs = 10MHz, -3dB)	—	-87	-85	—	-87	-85	—	-87	-82	dB
Input Bandwidth (-3dB)										
Small Signal (-20dB input)	—	25	—	—	25	—	—	25	—	MHz
Large Signal (-0.5dB input)	—	15	—	—	25	—	—	15	—	MHz
Feedthrough Rejection	—	90	—	—	90	—	—	90	—	dB
(fin = 1MHz)	—	90	—	—	90	—	—	90	—	dB
Slew Rate	—	±400	—	—	±400	—	—	±400	—	V/μs
Aperture Delay Time	—	4	—	—	4	—	—	4	—	ns
Aperture Uncertainty	—	0.2	—	—	0.2	—	—	0.2	—	ps rms
S/H Acquisition Time	—	40	—	—	40	—	—	45	—	ns
(to ±0.001%FSR, 5.5V step)	—	40	—	—	40	—	—	45	—	ns
Overvoltage Recovery Time ⑤	—	100	—	—	100	—	—	100	—	ns
A/D Conversion Rate	10	—	—	10	—	—	10	—	—	MHz

DYNAMIC PERFORMANCE (Cont.)	+25°C			0 TO +70°C			-55 TO +125°C			UNITS
	MIN.	TYP.	MAX.	MIN.	TYP.	MAX.	MIN.	TYP.	MAX.	
ANALOG OUTPUT										
Internal Reference										
Voltage	—	+3.2	—	—	+3.2	—	—	+3.2	—	Volts
Drift	—	±30	—	—	±30	—	—	±30	—	ppm/°C
External Current	—	5	—	—	5	—	—	5	—	mA
DIGITAL OUTPUTS										
Logic Levels										
Logic "1"	+2.4	—	—	+2.4	—	—	+2.4	—	—	Volts
Logic "0"	—	—	+0.4	—	—	+0.4	—	—	+0.4	Volts
Logic Loading "1"	—	—	-4	—	—	-4	—	—	-4	mA
Logic Loading "0"	—	—	+4	—	—	+4	—	—	+4	mA
Output Coding ⑥	(Offset) Binary / Complementary (Offset) Binary / Two's Complement / Complementary Two's Complement									
POWER REQUIREMENTS										
Power Supply Ranges ⑦										
+5V Supply	+4.75	+5.0	+5.25	+4.75	+5.0	+5.25	+4.9	+5.0	+5.25	Volts
-5V Supply	-4.75	-5.0	-5.25	-4.75	-5.0	-5.25	-4.9	-5.0	-5.25	Volts
+12V Supply ⑧	+11.5	+12.0	+12.5	+11.5	+12.0	+12.5	+11.5	+12.0	+12.5	Volts
-12V Supply ⑧	-11.5	-12.0	-12.5	-11.5	-12.0	-12.5	-11.5	-12.0	-12.5	Volts
+15V Supply ⑧	+14.5	+15.0	+15.5	+14.5	+15.0	+15.5	+14.5	+15.0	+15.5	Volts
-15V Supply ⑧	-14.5	-15.0	-15.5	-14.5	-15.0	-15.5	-14.5	-15.0	-15.5	Volts
Power Supply Currents										
+5V Supply	—	+50	—	—	TBD	—	—	TBD	—	mA
-5V Supply	—	-36	—	—	TBD	—	—	TBD	—	mA
-12/15V Supply ⑧	—	-25	—	—	TBD	—	—	TBD	—	mA
+12/15V Supply ⑧	—	+70	—	—	TBD	—	—	TBD	—	mA
Power Dissipation	—	1.5	TBD	—	TBD	TBD	—	TBD	TBD	Watts
Power Supply Rejection	—	—	±0.07	—	—	±0.07	—	—	±0.07	%FSR/%V
Footnotes:										
① All power supplies must be on before applying a start convert pulse. All supplies and the clock (START CONVERT) must be present during warm-up periods. The device must be continuously converting during this time.					⑤ This is the time required before the A/D output data is valid once the analog input is back within the specified range.					
② When COMP. BITS (pin 35) is low, logic loading "0" will be -350µA.					⑥ See table 2a, Setting Output Coding Selection.					
③ A 10MHz clock with a 50nsec positive pulse width is used for all production testing. See Timing Diagram for more details.					⑦ The minimum supply voltages of +4.9V and -4.9V for ±VDD are required for -55°C operation only. The minimum limits are +4.75V and -4.75V when operating at +125°C.					
④ Effective bits is equal to: $\frac{(\text{SNR} + \text{Distortion}) - 1.76}{6.02} + \left[20 \log \frac{\text{Full Scale Amplitude}}{\text{Actual Input Amplitude}} \right]$					⑧ ±12V only or ±15V only required.					

TECHNICAL NOTES

- Obtaining fully specified performance from the ADS-939A requires careful attention to pc-card layout and power supply decoupling. The device's analog and digital ground systems are connected to each other internally. For optimal performance, tie all ground pins (4, 7, 30 and 36) directly to a large **analog** ground plane beneath the package. For the best performance it is recommended to use a single power source for both the +5V analog and +5V digital supplies. Bypass all power supplies and the +3.2V reference output to ground with 4.7µF tantalum capacitors in parallel with 0.1µF ceramic capacitors. Locate the bypass capacitors as close to the unit as possible.
- The ADS-939A achieves its specified accuracies without the need for external calibration. If required, the device's small initial offset and gain errors can be reduced to zero using the adjustment circuitry shown in Figure 2. When using this circuitry, or any similar offset and gain calibration hardware, make adjustments following warm-up. To avoid interaction, always adjust offset before gain. Tie pins 5 and 6 to ANALOG GROUND (pin 4) if not using offset and gain adjust circuits.
- Pin 35 (COMP. BITS) is used to select the digital output coding format of the ADS-939A. See Tables 2a and 2b. When this pin has a TTL logic "0" applied, it complements all of the ADS-939A's digital outputs. When pin 35 has a logic "1" applied, the output coding is comple-

mentary (offset) binary. Applying a logic "0" to pin 35 changes the coding to (offset) binary. Using the MSB output (pin 29) instead of the MSB output (pin 28) changes the respective output codings to complementary two's complement and two's complement.

Pin 35 is TTL compatible and can be directly driven with digital logic in applications requiring dynamic control over its function. There is an internal pull-up resistor on pin 35 allowing it to be either connected to +5V or left open when a logic "1" is required.

- To enable the three-state outputs, connect OUTPUT ENABLE (pin 34) to a logic "0" (low). To disable, connect pin 34 to a logic "1" (high).
- Applying a start convert pulse while a conversion is in progress (EOC = logic "1") will initiate a new and probably inaccurate conversion cycle. Data from both the interrupted and subsequent conversions will be invalid.
- Do not enable/disable or complement the output bits or read from the FIFO during the conversion process (from the rising edge of EOC to the falling edge of EOC).
- The OVERFLOW bit (pin 33) switches from 0 to 1 when the input voltage exceeds that which produces an output of all 1's or when the input equals or exceeds the voltage that produces all 0's. When COMP BITS is activated, the above conditions are reversed.

CALIBRATION PROCEDURE

Connect the converter per Figure 2. Any offset/gain calibration procedures should not be implemented until the device is fully warmed up. To avoid interaction, adjust offset before gain. The ranges of adjustment for the circuits in Figure 2 are guaranteed to compensate for the ADS-939's initial accuracy errors and may not be able to compensate for additional system errors.

A/D converters are calibrated by positioning their digital outputs exactly on the transition point between two adjacent digital output codes. This is accomplished by connecting

LED's to the digital outputs and performing adjustments until certain LED's "flicker" equally between on and off. Other approaches employ digital comparators or microcontrollers to detect when the outputs change from one code to the next.

For the ADS-939, offset adjusting is normally accomplished when the analog input is 0 minus 1/2 LSB (-42µV). See Table 2b for the proper bipolar output coding.

Gain adjusting is accomplished when the analog input is at nominal full scale minus 1 1/2 LSB's (+2.749874V or -5.499874V).

Note: Connect pin 5 to ANALOG GROUND (pin 4) for operation without zero/offset adjustment. Connect pin 6 to pin 4 for operation without gain adjustment.

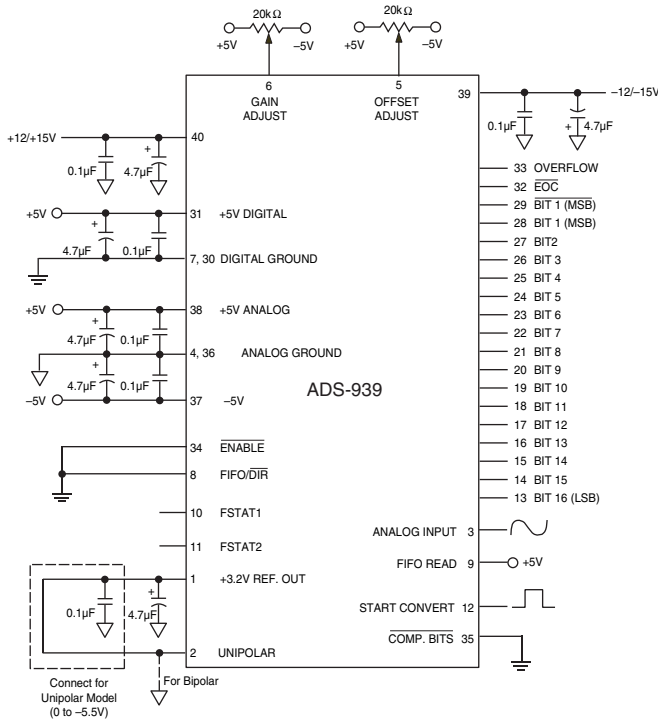

Figure 2. Connection Diagram

Table 2a. Setting Output Coding Selection (Pin 35)

OUTPUT FORMAT	PIN 35 LOGIC LEVEL
Complementary (Offset) Binary	1
(Offset) Binary	0
Complementary Two's Complement (Using MSB, pin 29)	1
Two's Complement (Using MSB, pin 29)	0

Zero/Offset Adjust Procedure

1. Apply a train of pulses to the START CONVERT input (pin 12) so that the converter is continuously converting.
2. For zero/offset adjust, apply -42µV to the ANALOG INPUT (pin 3).
3. For bipolar operation - Adjust the offset potentiometer until the code flickers between 1000 0000 0000 0000 and 0111 1111 1111 1111 with pin 35 tied high (complementary offset binary) or between 0111 1111 1111 1111 and 1000 0000 0000 0000 with pin 35 tied low (offset binary).

For unipolar operation - Adjust the offset potentiometer until all outputs are 1's and the LSB flickers between 0 and 1 with pin 35 tied high (complementary binary) or until all outputs are 0's and the LSB flickers between 0 and 1 with pin 35 tied low (binary).

4. For bipolar, Two's complement coding requires using BIT 1 (MSB) (pin 29). With pin 35 tied low, adjust the trimpot until the output code flickers between all 0's and all 1's.

Gain Adjust Procedure

1. For gain adjust, for bipolar apply +2.749874V and for unipolar mode 5.499874V to the ANALOG INPUT (pin 3).
2. Adjust the gain potentiometer until all output bits are 0's and the LSB flickers between a 1 and 0 with pin 35 tied high (complementary (offset) binary) or until all output bits are 1's and the LSB flickers between a 1 and 0 with pin 35 tied low ((offset) binary).
3. For bipolar, Two's complement coding requires using BIT 1 (MSB) (pin 29). With pin 35 tied low, adjust the gain trimpot until the output code flickers equally between 0111 1111 1111 1111 and 0111 1111 1111 1110.
4. To confirm proper operation of the device, vary the applied input voltage to obtain the output coding listed in Table 2b.

Table 2b. Output Coding

INPUT RANGE 0 to -5.5V	UNIPOLAR SCALE	COMP. BINARY		BINARY		COMP. TWO'S COMP.		TWO'S COMP.		INPUT RANGE ±2.75V	BIPOLAR SCALE
		MSB	LSB	MSB	LSB	MSB	LSB	MSB	LSB		
0 -1 LSB	-0.000084	1111	1111 1111 1111	0000	0000 0000 0000	0111	1111 1111 1111	1000	0000 0000 0000	+2.749916	+FS -1 LSB
0 -1 1/2 LSB	-0.000126	LSB "1" to "0"		LSB "0" to "1"		LSB "1" to "0"		LSB "0" to "1"		+2.749874	+FS -1 1/2 LSB
0 - 1/8 FS	-0.687500	1110	0000 0000 0000	0001	1111 1111 1111	0110	0000 0000 0000	1001	1111 1111 1111	+2.062500	+3/4 FS
0 - 1/4 FS	-1.375000	1100	0000 0000 0000	0011	1111 1111 1111	0100	0000 0000 0000	1011	1111 1111 1111	+1.375000	+1/2 FS
-1/2 FS -1/2LSB	-2.749958	1000	0000 0000 0000	0111	1111 1111 1111	0000	0000 0000 0000	1111	1111 1111 1111	0.000000	0
-1/2 LSB	-2.750000	0111	1111 1111 1111	1000	000 000 0000	1111	1111 1111 1111	0000	0000 0000 0000	-0.000084	-1 LSB
-3/4 FS	-4.125000	0100	0000 0000 0000	1011	1111 1111 1111	1100	0000 0000 0000	0011	1111 1111 1111	-1.375000	-1/2 FS
-7/8 FS	-4.812500	0010	0000 0000 0000	1101	1111 1111 1111	1010	0000 0000 0000	0101	1111 1111 1111	-2.062500	-3/4 FS
-FS +1 LSB	-5.499916	0000	0000 0000 0001	1111	1111 1111 1110	1000	0000 0000 0001	0111	1111 1111 1110	-2.749916	-FS +1 LSB
-FS + 1/2 LSB	-5.499958	LSB "0" to "1"		LSB "1" to "0"		LSB "0" to "1"		LSB "1" to "0"		-2.749958	-FS + 1/2 LSB
-FS	-5.500000	0000	0000 0000 0000	1111	1111 1111 1111	1000	0000 0000 0000	0111	1111 1111 1111	-2.750000	-FS
		OFFSET BINARY		COMP. OFF. BIN.		TWO'S COMP.		COMP. TWO'S COMP.			

THERMAL REQUIREMENTS

All DATEL sampling A/D converters are fully characterized and specified over operating temperature (case) ranges of 0 to +70°C and -55 to +125°C. All room-temperature (TA = +25°C) production testing is performed without the use of heat sinks or forced-air cooling. Thermal impedance figures for each device are listed in their respective specification tables.

These devices do not normally require heat sinks, however, standard precautionary design and layout procedures should be used to ensure devices do not overheat. The ground and power planes beneath the package, as well as all pcb signal runs to and from the device, should be as heavy as possible to help conduct heat away from the package. Electrically insulating, thermally-conductive "pads" may be installed

underneath the package. Devices should be soldered to boards rather than "socketed", and of course, minimal air flow over the surface can greatly help reduce the package temperature.

In more severe ambient conditions, the package/junction temperature of a given device can be reduced dramatically (typically 35%) by using one of DATEL's HS Series heat sinks. See Ordering Information for the assigned part number. See page 1-183 of the DATEL Data Acquisition Components Catalog for more information on the HS Series. Request DATEL Application Note AN-8, "Heat Sinks for DIP Data Converters," or contact DATEL directly, for additional information.

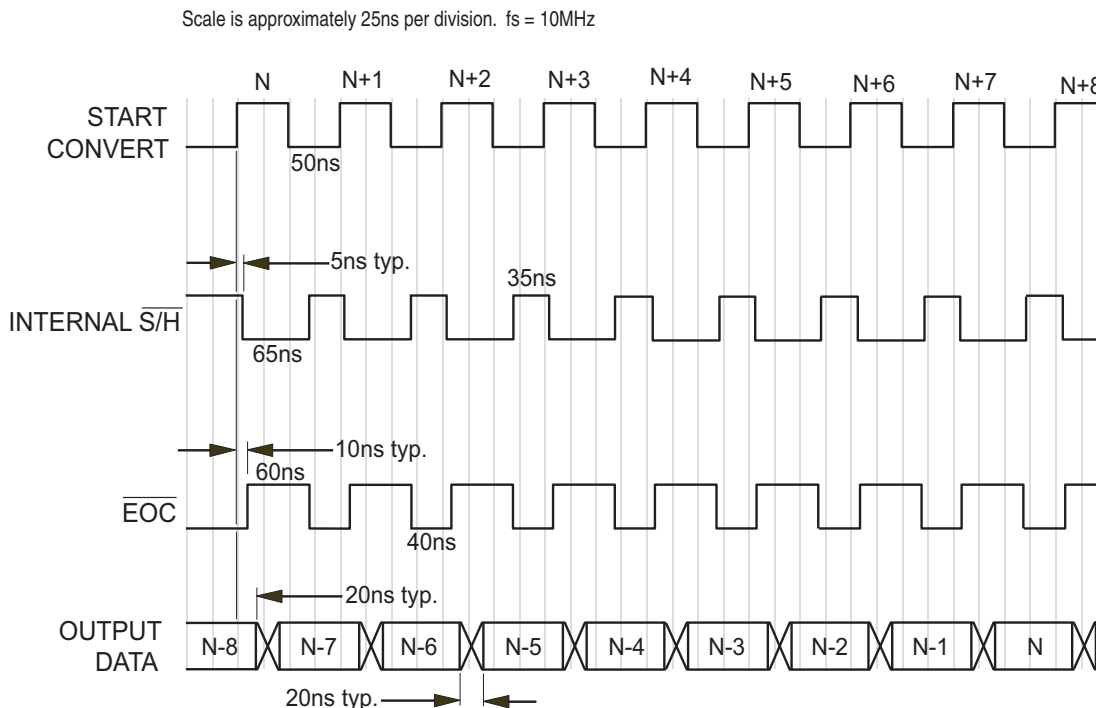
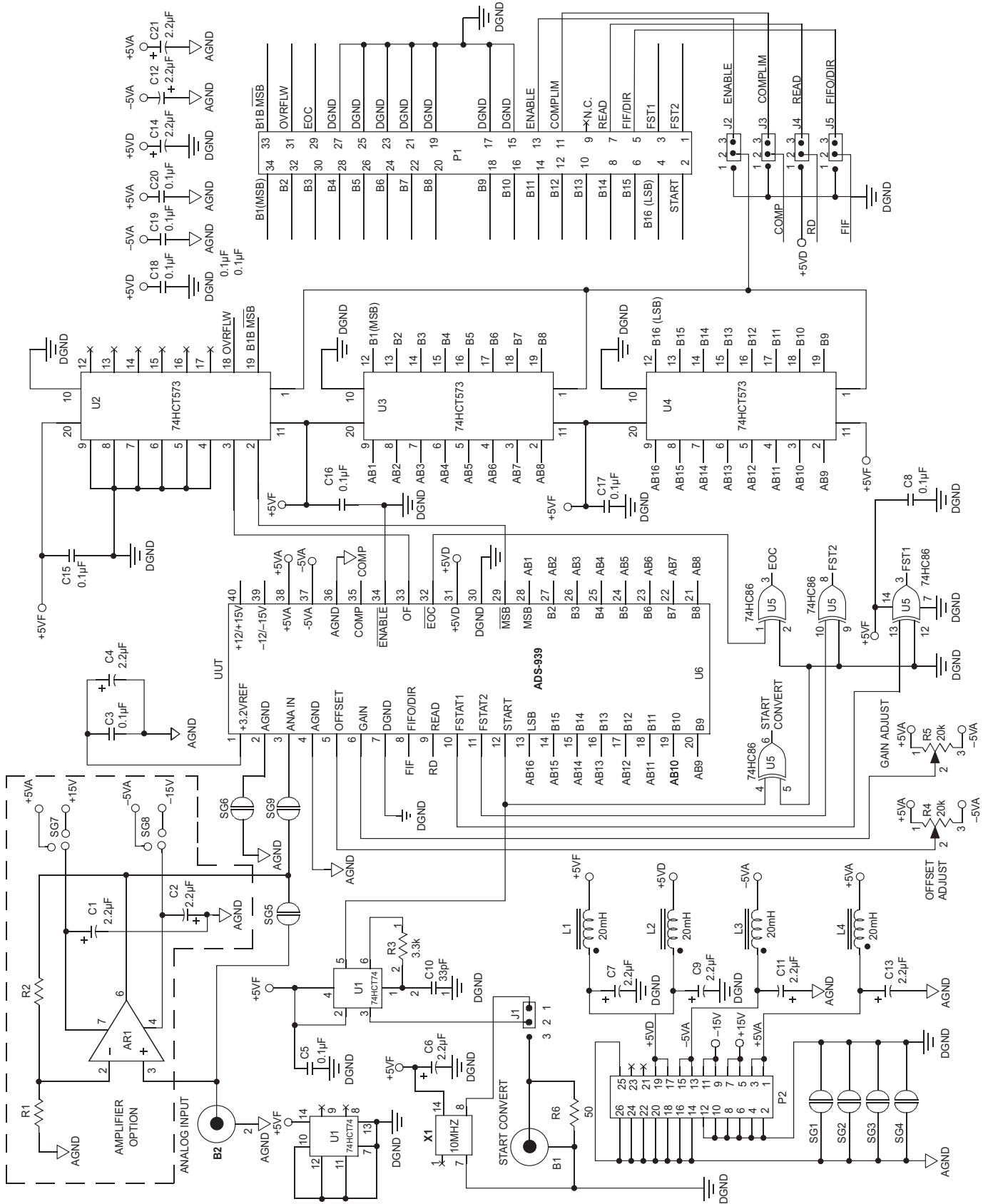

Figure 3. ADS-939 Timing Diagram



Preliminary Evaluation Board - Modified ADS-B933 to include ±12V or ±15V Supplies to U6

Figure 4. ADS-939 Evaluation Board Schematic.

MECHANICAL DIMENSIONS INCHES (mm)

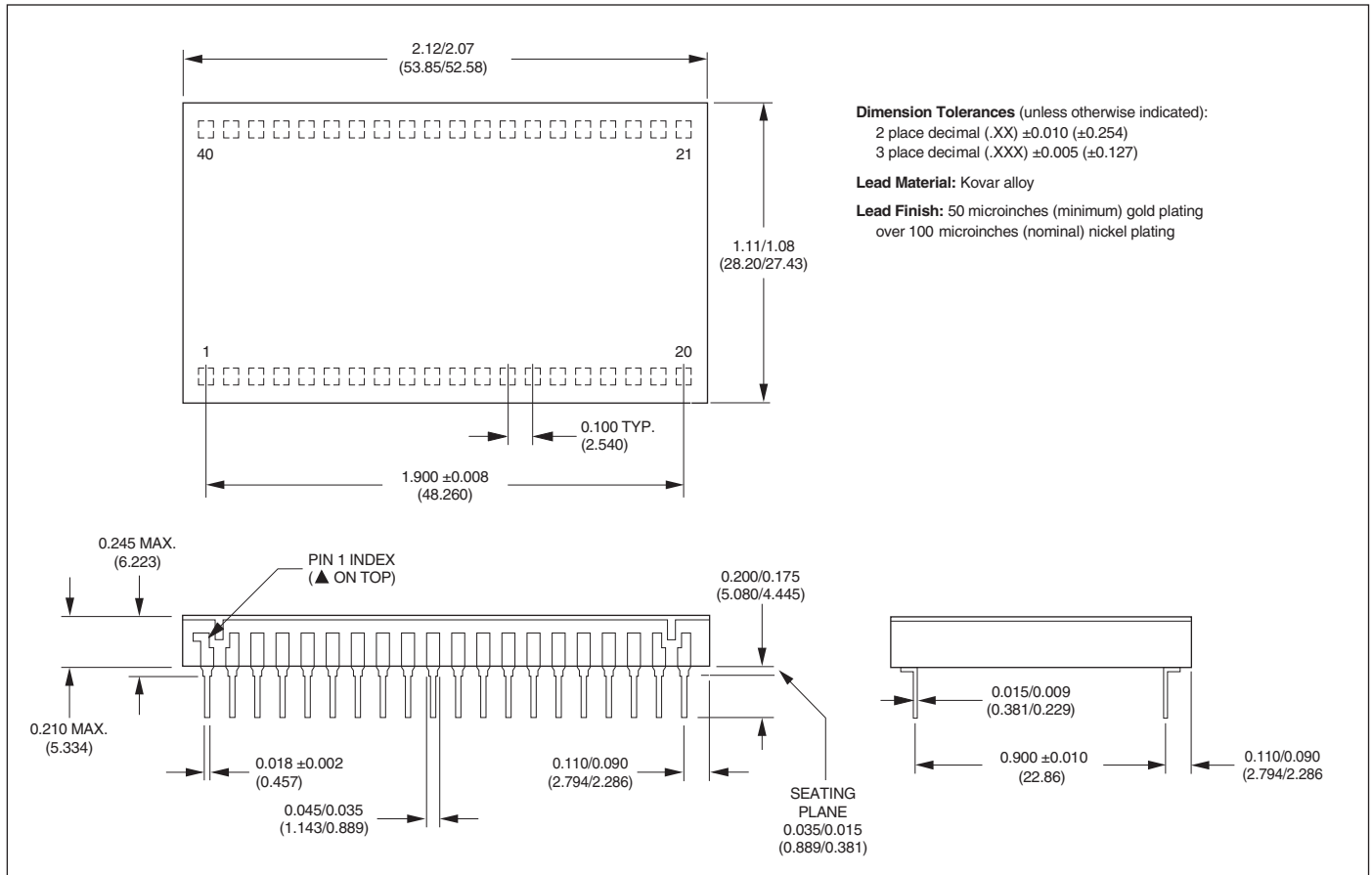

ORDERING INFORMATION

MODEL	OPERATING TEMP. RANGE	ACCESSORIES
ADS-939MC	0 to +70°C	ADS-B939 Evaluation Board (without ADS-939)
ADS-939MM	-55 to +125°C	HS-40 Heat Sink for all ADS-939 models

Receptacles for PC board mounting can be ordered through AMP, Inc., Part # 3-331272-8 (Component Lead Socket), 40 required. For MIL-STD-883 product, or surface mount packaging, contact DATEL.