

BRIGHT LED ELECTRONICS CORP.

查询"BL-HUB36D"供应信息 SURFACE MOUNT CHIP LED LAMP SPECIFICATION

●COMMODITY : SURFACE MOUNT CHIP LED LAMP

●DEVICE NUMBER : BL-HUB36D

PAGE: 2

●ELECTRICAL AND OPTICAL CHARACTERISTICS (Ta=25°C)

REVISION: 1.1

| Chip | | | Lens Appearance | Absolute Maximum Rating | | | | Electro-optical Data (At 20mA) | | | | Viewing Angle 2θ 1/2 (deg) |
|---------------|-----------------------------|---------------------------------|--------------------|-------------------------|---------|---------|-------------|--------------------------------|------|---------|------|----------------------------------|
| Emitted Color | Peak Wave Length λ p(nm) | Dominant Wave Length λ d(nm) | | Δ λ (nm) | Pd (mW) | If (mA) | Peak If(mA) | Vf(V) | | Iv(mcd) | | |
| | | | | | | | | Typ. | Max. | Min | Typ. | |
| Super Red | 645 | 632±5 | Water Clear | 22 | 80 | 30 | 100 | 2.1 | 2.6 | 28.0 | 50.0 | 120 |

Remark : Viewing angle is the Off-axis angle at which the luminous intensity is half the axial luminous intensity.

●ABSOLUTE MAXIMUM RATINGS (Ta=25°C)

Reverse Voltage 5V
 Reverse Current (VR=5V) ≤100μA
 Operating Temperature Range -25°C ~ 80°C
 Storage Temperature Range -30°C ~ 85°C

●PACKAGE DIMENSIONS

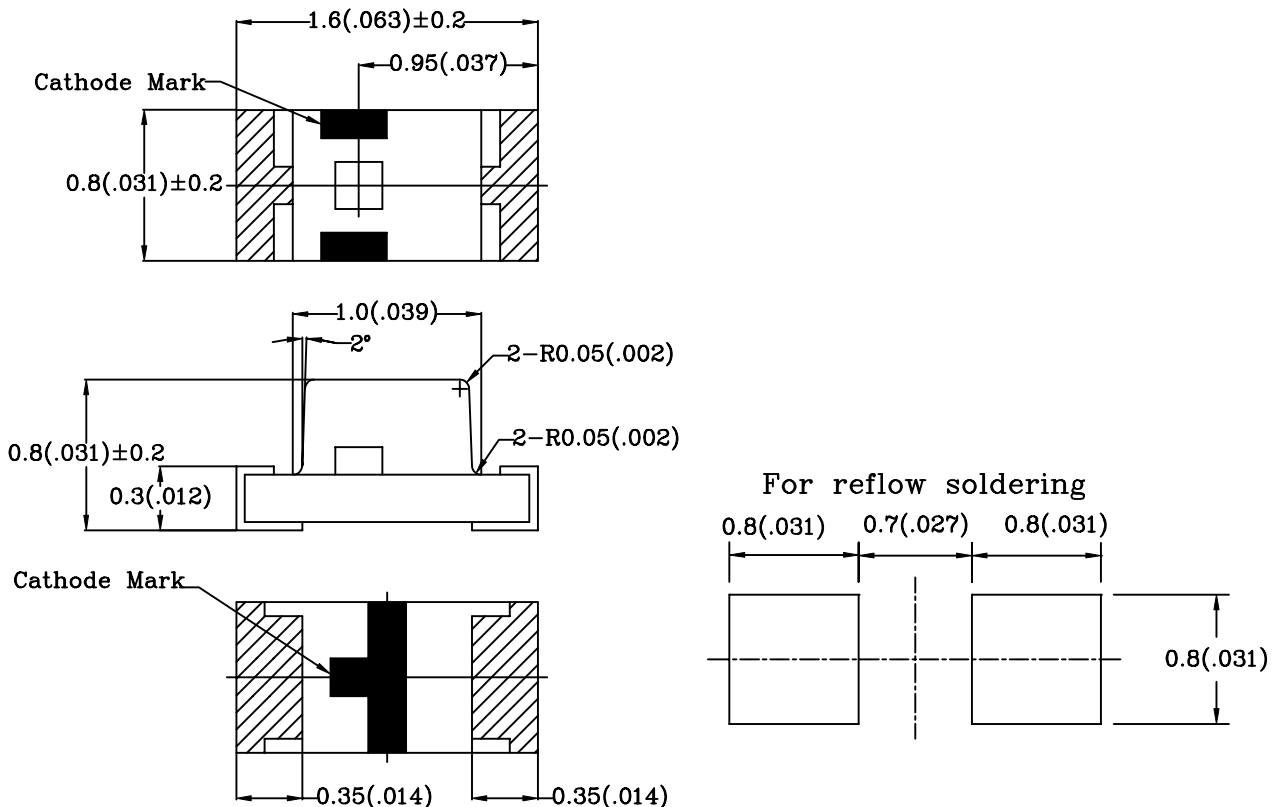

- NOTES: 1.All dimensions are in millimeters (inches).
 2.Tolerance is ± 0.10mm (0.004) unless otherwise specified.
 3.Specifications are subject to change without notice.
 4.Condition for IFp is pulse of 1/10 duty and 0.1msec width.

BRIGHT LED ELECTRONICS CORP.

查询"BL-HUB36D-TRB"供应商

SURFACE MOUNT CHIP LED LAMP SPECIFICATION

● COMMODITY : SURFACE MOUNT CHIP LED LAMP

● DEVICE NUMBER : BL-HUB36D

● ELECTRICAL AND OPTICAL CHARACTERISTICS (Ta=25°C)

PAGE: 3

REVISION: 1.1

Fig.1 RELATIVE INTENSITY VS. WAVELENGTH

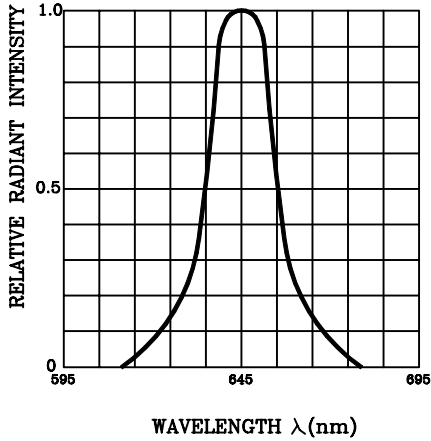

Fig.2 FORWARD CURRENT DERATING CURVE

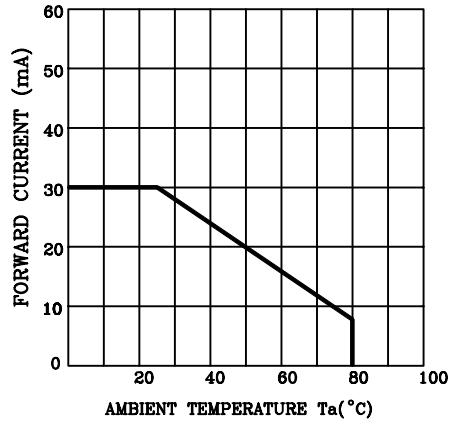

Fig.3 FORWARD CURRENT VS. FORWARD VOLTAGE

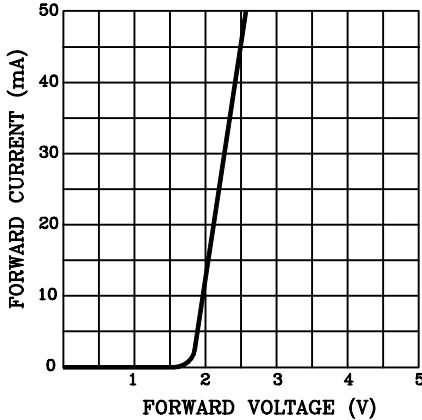

Fig.4 RELATIVE LUMINOUS INTENSITY VS. AMBIENT TEMPERATURE

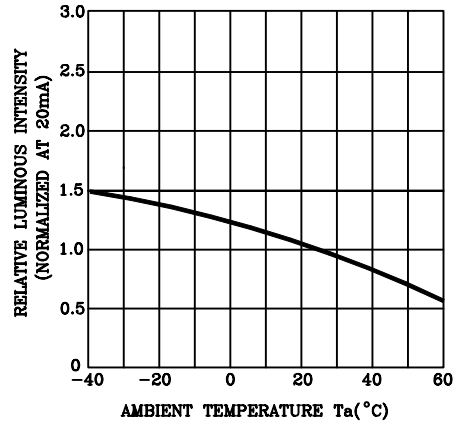

Fig.5 RELATIVE LUMINOUS INTENSITY VS. FORWARD CURRENT

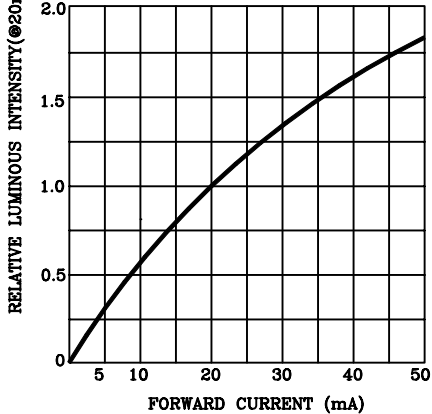
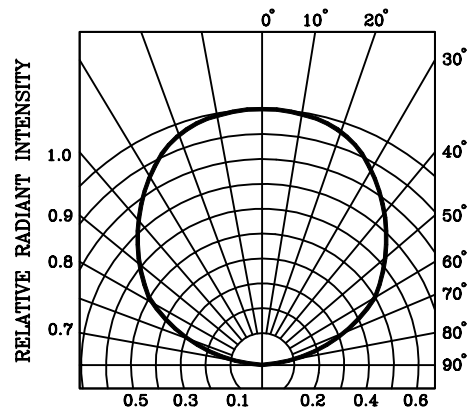

Fig.6 RADIATION DIAGRAM



BRIGHT LED ELECTRONICS CORP.

SURFACE MOUNT CHIP LED LAMP SPECIFICATION

[查询"BL-HUB36D-TRB"供应商](#)

●COMMODITY : SURFACE MOUNT CHIP LED LAMP

●DEVICE NUMBER : BL-HUB36D-TRB

PAGE: 4

●-TRB: TAPPING & REELING, BLACK CAMRIER TAPE, ESD RESISTED.

REVISION: 1.1

●TAPPING AND PACKAGING SPECIFICATION

●ELECTRICAL AND OPTICAL CHARACTERISTICS (Ta=25°C)

| ITEM | SYMBOL | SPECIFICATION | | | |
|--|----------------|---------------|-------|---------|-------|
| | | Minimum | | Maximum | |
| | | mm | inch | mm | inch |
| Tape Feed Hole Diameter (DIA) | D ₀ | 1.40 | 0.055 | 1.60 | 0.063 |
| Feed Hole Location | E | 1.65 | 0.064 | 1.85 | 0.073 |
| Centers Line Dimensions Length Direction | F | 3.45 | 0.135 | 3.55 | 0.139 |
| Compartment Depth | K ₀ | 0.94 | 0.037 | 1.14 | 0.045 |
| Compartment Pitch | P | 3.90 | 0.153 | 4.10 | 0.161 |
| Sprocket Hole Diameter | P ₀ | 3.90 | 0.153 | 4.10 | 0.161 |
| Centers Line Dimensions Length Direction | P ₂ | 1.95 | 0.076 | 2.05 | 0.080 |
| Carrier Tape Thickness | t | — | — | 0.30 | 0.012 |
| Carrier Tape Width | W | 7.70 | 0.303 | 8.30 | 0.326 |
| Flange Diameter | A | 178.0 | 7.008 | 180.0 | 7.087 |
| Hub Spindle Hole | C | 12.50 | 0.492 | 13.50 | 0.531 |
| Hub Diameter | D ₂ | 70.00 | 2.755 | 72.00 | 2.830 |
| Fixing Tape Width | W ₁ | 5.25 | 0.206 | 5.35 | 0.210 |
| Flange Space Between Flanges | T | 12.50 | 0.492 | 13.50 | 0.531 |
| Compartment Length | A ₀ | 0.98 | 0.039 | 1.18 | 0.046 |
| Compartment Width | B ₀ | 1.78 | 0.070 | 1.98 | 0.078 |

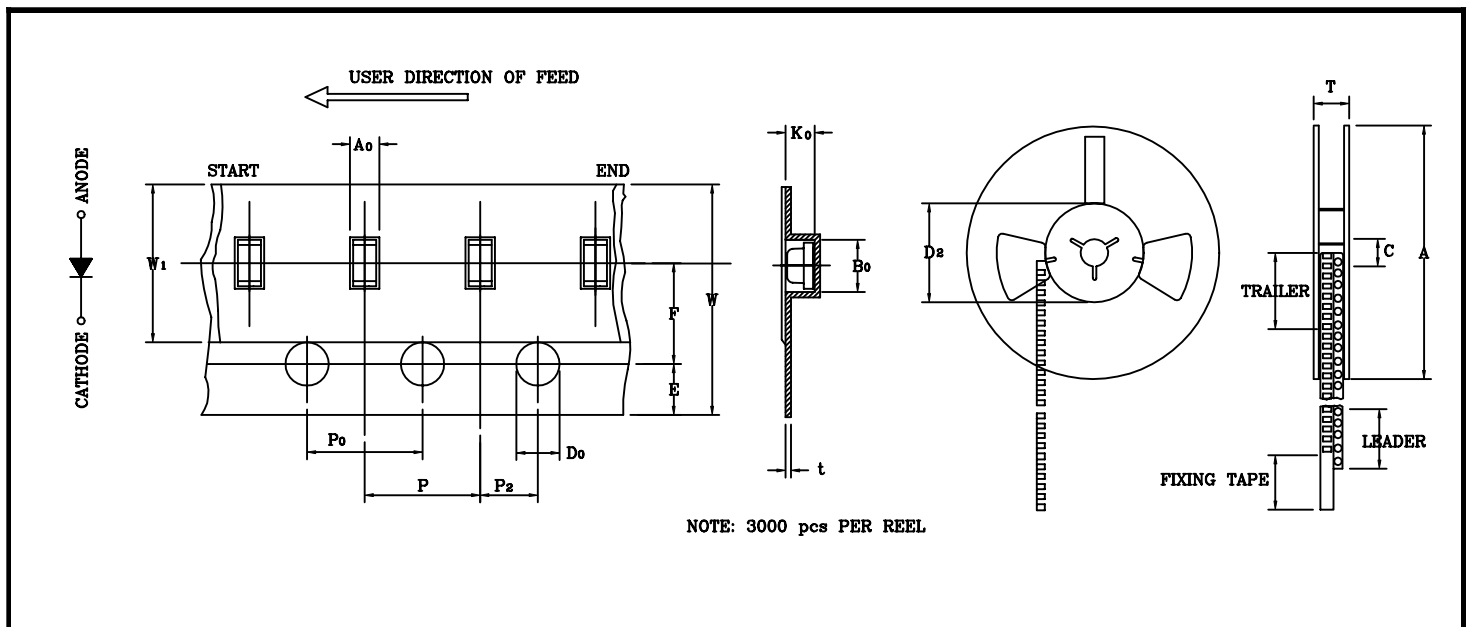

BRIGHT LED ELECTRONICS CORP.

SURFACE MOUNT CHIP LED LAMP SPECIFICATION

RELIABILITY TEST

PAGE: 5

REVISION: 1.0

| Classification | Test Item | Reference Standard | Test Conditions | Result |
|--------------------|--|---|---|--------|
| Endurance Test | Operation Life | MIL-STD-750:1026 MIL-STD-883:1005 JIS C 7021 :B-1 | Connect with a power $I_f=20\text{mA}$ T_a =Under room temperature Test time=1,000hrs | 0/20 |
| | High Temperature High Humidity Storage | MIL-STD-202:103B JIS C 7021 :B-11 | $T_a=+65^\circ\text{C}\pm 5^\circ\text{C}$ RH=90%-95% Test time=240hrs | 0/20 |
| | High Temperature Storage | MIL-STD-883:1008 JIS C 7021 :B-10 | High $T_a=+85^\circ\text{C}\pm 5^\circ\text{C}$ Test time=1,000hrs | 0/20 |
| | Low Temperature Storage | JIS-C-7021 :B-12 | Low $T_a=-35^\circ\text{C}\pm 5^\circ\text{C}$ Test time=1,000hrs | 0/20 |
| Environmental Test | Temperature Cycling | MIL-STD-202:107D MIL-STD-750:1051 MIL-STD-883:1010 JIS C 7021 :A-4 | $-35^\circ\text{C} \sim +25^\circ\text{C} \sim +85^\circ\text{C} \sim +25^\circ\text{C}$ 60min 20min 60min 20min Test Time=5cycle | 0/20 |
| | Thermal Shock | MIL-STD-202:107D MIL-STD-750:1051 MIL-STD-883:1011 | $-35^\circ\text{C}\pm 5^\circ\text{C} \sim +85^\circ\text{C}\pm 5^\circ\text{C}$ 20min 20min Test Time=10cycle | 0/20 |
| | Solder Resistance | MIL-STD-202:201A MIL-STD-750:2031 JIS C 7021 :A-1 | Preheating : $140^\circ\text{C} - 160^\circ\text{C}$, within 2 minutes. Operation heating : $235^\circ\text{C}(\text{Max.})$, within 10seconds. (Max.) | 0/20 |

JUDGMENT CRITERIA OF FAILURE FOR THE RELIABILITY

| Measuring items | Symbol | Measuring conditions | Judgement criteria for failure |
|--------------------|------------------|----------------------|--------------------------------|
| Forward voltage | V_F (V) | $I_f=20\text{mA}$ | Over $U_x1.2$ |
| Reverse current | $I_r(\text{uA})$ | $V_r=5\text{V}$ | Over U_x2 |
| Luminous intensity | I_v (mcd) | $I_f=20\text{mA}$ | Below $SX0.5$ |

Note: 1.U means the upper limit of specified characteristics. S means initial value.

2.Measurment shall be taken between 2 hours and after the test pieces have been returned to normal ambient conditions after completion of each test.

BRIGHT LED ELECTRONICS CORP.

SURFACE MOUNT CHIP LED LAMP SPECIFICATION

PAGE: 6

REVISION: 1.0

1. SOLDERING:

● **Manual Of Soldering**

The temperature of the iron tip should not be higher than 300°C (572°F) and Soldering within 3 seconds per solder-land is to be observed.

● **Reflow Soldering**

Preheating : 140°C~160°C±5°C, within 2 minutes.

Operation heating : 235°C (MAX.) within 10 seconds.(Max)

Gradual Cooling (Avoid quenching).

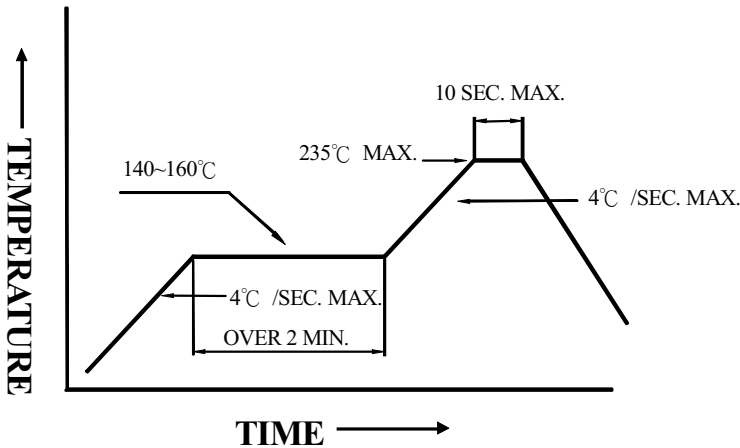

● **DIP soldering (Wave Soldering)**

Preheating : 120°C~150°C, within 120~180 sec.

Operation heating : 245°C±5°C within 5 sec. 260°C (Max)

Gradual Cooling (Avoid quenching).

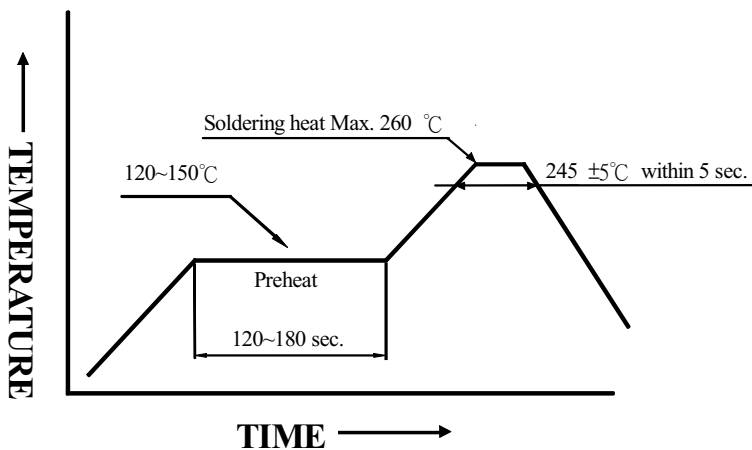

2. Handling :

Care must be taken not to cause to the epoxy resin portion of BRIGHT LEDs while it is exposed to high temperature.

Care must be taken not rub the epoxy resin portion of BRIGHT LEDs with hard or sharp article such as the sand blast and the metal hook.