

## 4-BRIDGE SERIAL INTERFACE MOTOR DRIVER

 Check for Samples: [DRV8823](#)

### FEATURES

- **PWM motor Driver with Four H-Bridges**
  - Drives Two Stepper Motors, One Stepper and Two DC Motors, or Four DC Motors
  - Up to 1.5-A Current Per Winding
  - Low On-Resistance
  - Programmable Maximum Winding Current
  - Three-Bit Winding Current Control Allows up to Eight Current Levels
  - Selectable Slow or Mixed Decay Modes
- **8-V to 32-V Operating Supply Voltage Range**
- **Internal Charge Pump for Gate Drive**
- **Built-in 3.3-V Reference**

- **Serial Digital Control Interface**
- **Fully Protected Against Undervoltage, Overtemperature, and Overcurrent**
- **Thermally Enhanced Surface Mount Package**

### APPLICATIONS

- **Printers**
- **Scanners**
- **Office Automation Machines**
- **Gaming Machines**
- **Factory Automation**
- **Robotics**

### DESCRIPTION/ORDERING INFORMATION

The DRV8823 provides an integrated motor driver solution for printers and other office automation equipment applications.

The motor driver circuit includes four H-bridge drivers. Each of the motor driver blocks employ N-channel power MOSFETs configured as an H-bridge to drive the motor windings.

A simple serial interface allows control of all functions of the motor driver with only a few digital signals. A low-power sleep function is also provided.

The motor drivers provide PWM current control capability. The current is programmable, based on an externally supplied reference voltage and an external current sense resistor. In addition, eight current levels (set via the serial interface) allow microstepping with bipolar stepper motors.

Internal shutdown functions are provided for over current protection, short circuit protection, under voltage lockout and overtemperature.

The DRV8823 is packaged in a 48 pin HTSSOP package (Eco-friendly : RoHS & no Sb/Br).

#### ORDERING INFORMATION<sup>(1)</sup>

T <sub>A</sub>	PACKAGE <sup>(2)</sup>		ORDERABLE PART NUMBER	TOP-SIDE MARKING
-40°C to 85°C	PowerPad™ (HTSSOP) - DCA	Reel of 2000	DRV8823DCAR	DRV8823
		Tube of 40	DRV8823DCA	

(1) For the most current package and ordering information, see the Package Option Addendum at the end of this document, or see the TI web site at [www.ti.com](http://www.ti.com).

(2) Package drawings, thermal data, and symbolization are available at [www.ti.com/packaging](http://www.ti.com/packaging).



Please be aware that an important notice concerning availability, standard warranty, and use in critical applications of Texas Instruments semiconductor products and disclaimers thereto appears at the end of this data sheet.

PowerPad, PowerPAD are trademarks of Texas Instruments.

[查询 DRV8823 知识库](#)

FUNCTIONAL BLOCK DIAGRAM

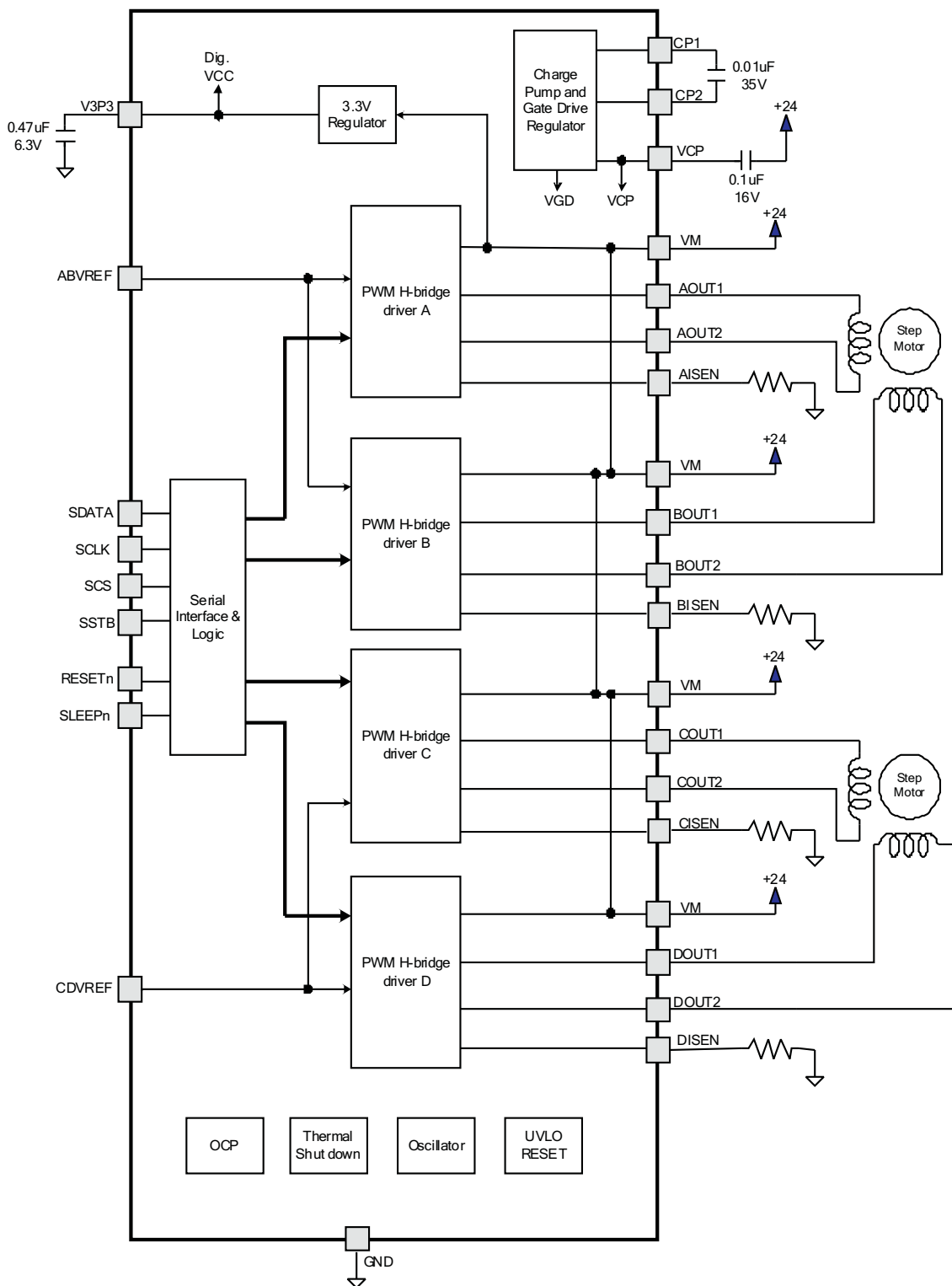

**TERMINAL FUNCTIONS**

NAME	NO.	I/O <sup>(1)</sup>	DESCRIPTION	EXTERNAL COMPONENTS OR CONNECTIONS
<b>POWER AND GROUND</b>				
VM (4 pins)	1, 2, 23, 24	-	Motor supply voltage (multiple pins)	Connect all VM pins together to motor supply voltage. Bypass to GND with several 0.1- $\mu$ F, 35-V ceramic capacitors.
V3P3	16	-	3.3 V regulator output	Bypass to GND with 0.47- $\mu$ F, 6.3-V ceramic capacitor.
GND	10 - 15, 34 - 39	-	Power ground (multiple pins)	Connect all PGND pins to GND and solder to copper heatsink areas.
CP1	7	IO	Charge pump flying capacitor	Connect a 0.01- $\mu$ F capacitor between CP1 and CP2
CP2	8	IO		
VCP	9	IO	Charge pump storage capacitor	Connect a 0.1- $\mu$ F, 16 V ceramic capacitor to V <sub>M</sub>
<b>MOTOR DRIVERS</b>				
ABVREF	17	I	Bridge A & B current set reference voltage	Sets current trip threshold.
AOUT1	5	O	Bridge A output 1	Connect to first coil of bipolar stepper motor 1, or DC motor winding.
AOUT2	3	O	Bridge A output 2	
ISENA	4	-	Bridge A current sense	Connect to current sense resistor for bridge A.
BOUT1	48	O	Bridge B output 1	Connect to second coil of bipolar stepper motor 1, or DC motor winding.
BOUT2	46	O	Bridge B output 2	
ISENB	47	-	Bridge B current sense	Connect to current sense resistor for bridge B.
CDVREF	18	I	Bridge C & D current set reference voltage	Sets current trip threshold.
COU1	27	O	Bridge C output 1	Connect to first coil of bipolar stepper motor 2, or DC motor winding.
COU2	25	O	Bridge C output 2	
ISENC	26	-	Bridge C current sense	Connect to current sense resistor for bridge C.
DOU1	22	O	Bridge D output 1	Connect to second coil of bipolar stepper motor 2, or DC motor winding.
DOU2	20	O	Bridge D output 2	
ISEND	22	-	Bridge D current sense	Connect to current sense resistor for bridge D.
<b>SERIAL INTERFACE</b>				
SDATA	31	I	Serial data input	Data is clocked in on rising edge of SCLK.
SCLK	33	I	Serial input clock	Logic high enables serial data to be clocked in.
SCS	45	I	Serial chip select	Logic high latches serial data.
SSTB	30	I	Serial data strobe	Active low resets serial interface and disables outputs.
RESETn	43	I	Reset input	Active low input disables outputs and charge pump.
SLEEPn	42	I	Sleep input	
<b>TEST PINS</b>				
TEST	19, 28, 29, 32	I	Test inputs	Do not connect these pins - used for factory test only.

(1) Directions: I = input, O = output, OZ = 3-state output, OD = open-drain output, IO = input/output, PU = internal pullup

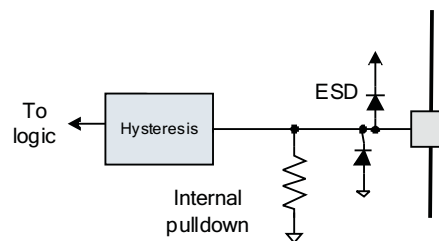

**Figure 1. Logic Inputs**

[查询 DRV8823 供货情况](#)

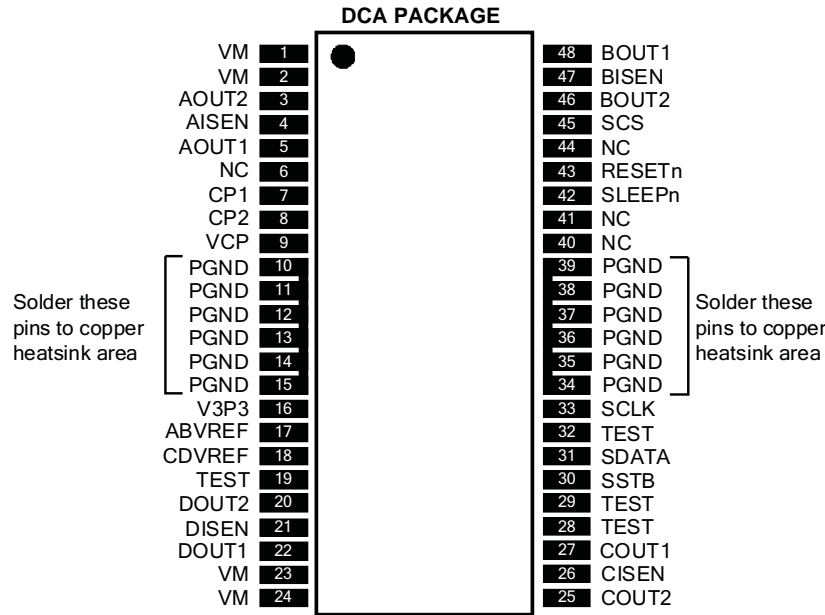

**ABSOLUTE MAXIMUM RATINGS<sup>(1) (2)</sup>**

over operating free-air temperature range (unless otherwise noted)

$V_M$	Power supply voltage range	-0.3 to 34	V
$V_I$	Logic input voltage range <sup>(3)</sup>	-0.5 to 5.75	V
$I_{O(peak)}$	Peak motor drive output current, $t < 1 \mu s$	Internally limited	
$I_O$	Motor drive output current <sup>(4)</sup>	1.5	A
$P_D$	Continuous total power dissipation	See Dissipation Ratings Table	
$T_J$	Operating virtual junction temperature range	-40 to 150	°C
$T_A$	Operating ambient temperature range	-40 to 85	°C
$T_{stg}$	Storage temperature range	-60 to 150	°C

- (1) Stresses beyond those listed under "absolute maximum ratings" may cause permanent damage to the device. These are stress ratings only, and functional operation of the device at these or any other conditions beyond those indicated under "recommended operating conditions" is not implied. Exposure to absolute-maximum-rated conditions for extended periods may affect device reliability.
- (2) All voltage values are with respect to network ground terminal.
- (3) Input pins may be driven in this voltage range regardless of presence or absence of  $V_M$ .
- (4) Power dissipation and thermal limits must be observed.

**DISSIPATION RATINGS**

BOARD	PACKAGE	$R_{\theta JA}$	DERATING FACTOR ABOVE $T_A = 25^\circ C$	$T_A < 25^\circ C$	$T_A = 70^\circ C$	$T_A = 85^\circ C$
Low-K <sup>(1)</sup>	DCA	75.7°C/W	13.2 mW/°C	1.65 W	1.06 W	0.86 W
Low-K <sup>(2)</sup>		32°C/W	31.3 mW/°C	3.91 W	2.50 W	2.03 W
High-K <sup>(3)</sup>		30.3°C/W	33 mW/°C	4.13 W	2.48 W	2.15 W
High-K <sup>(4)</sup>		22.3°C/W	44.8 mW/°C	5.61 W	3.59 W	2.91 W

- (1) The JEDEC Low-K board used to derive this data was a 76-mm x 114-mm, 2-layer, 1.6-mm thick PCB with no backside copper.
- (2) The JEDEC Low-K board used to derive this data was a 76-mm x 114-mm, 2-layer, 1.6-mm thick PCB with 25-cm<sup>2</sup> 2-oz copper on back side.
- (3) The JEDEC High-K board used to derive this data was a 76-mm x 114-mm, 4-layer, 1.6-mm thick PCB with no backside copper and solid 1-oz internal ground plane.
- (4) The JEDEC High-K board used to derive this data was a 76-mm x 114-mm, 4-layer, 1.6-mm thick PCB with 25-cm<sup>2</sup> 1-oz copper on back side and solid 1-oz internal ground plane.

## RECOMMENDED OPERATING CONDITIONS

over operating free-air temperature range (unless otherwise noted)

		MIN	NOM	MAX	UNIT
$V_M$	Motor power supply voltage range	8		32	V
$I_{MOT}$	Continuous motor drive output current <sup>(1)</sup>		1	1.5	A
$V_{REF}$	VREF input voltage	1		4	V

(1) Power dissipation and thermal limits must be observed.

## ELECTRICAL CHARACTERISTICS

over operating free-air temperature range (unless otherwise noted)

PARAMETER	TEST CONDITIONS	MIN	TYP	MAX	UNIT	
<b>POWER SUPPLIES</b>						
$I_{VM}$	$V_M$ operating supply current	$V_M = 24\text{ V}$ , no loads		5	8 mA	
$V_{UVLO}$	$V_M$ undervoltage lockout voltage	$V_M$ rising		6.5	8 V	
$V_{CP}$	Charge pump voltage	Relative to $V_M$		12	V	
$V_{V3P3}$	$V_{V3P3}$ output voltage	3.20	3.30	3.40	V	
<b>LOGIC-LEVEL INPUTS (INTERNAL PULLDOWNS)</b>						
$V_{IL}$	Input low voltage			0.7	V	
$V_{IH}$	Input high voltage	2			V	
$V_{HYS}$	Input hysteresis	0.3	0.45	0.6	V	
$I_{IN}$	Input current (internal pulldown current)	$V_{IN} = 3.3\text{ V}$		100	$\mu\text{A}$	
<b>OVERTEMPERATURE PROTECTION</b>						
$T_{TSD}$	Thermal shutdown temperature	Die temperature		150	$^{\circ}\text{C}$	
<b>MOTOR DRIVERS</b>						
$R_{ds(on)}$	Motor #1 FET on resistance (each individual FET)	$V_M = 24\text{ V}$ , $I_O = 0.8\text{ A}$ , $T_J = 25^{\circ}\text{C}$		0.25	$\Omega$	
		$V_M = 24\text{ V}$ , $I_O = 0.8\text{ A}$ , $T_J = 85^{\circ}\text{C}$		0.31 0.37		
$R_{ds(on)}$	Motor #2 FET on resistance (each individual FET)	$V_M = 24\text{ V}$ , $I_O = 0.8\text{ A}$ , $T_J = 25^{\circ}\text{C}$		0.30	$\Omega$	
		$V_M = 24\text{ V}$ , $I_O = 0.8\text{ A}$ , $T_J = 85^{\circ}\text{C}$		0.38 0.45		
$I_{OFF}$	Off-state leakage current			$\pm 12$	$\mu\text{A}$	
$f_{PWM}$	Motor PWM frequency <sup>(1)</sup>	45	50	55	kHz	
$t_{BLANK}$	ITRIP blanking time <sup>(2)</sup>		3.75		$\mu\text{s}$	
$t_F$	Output fall time	50		300	ns	
$t_R$	Output rise time	50		300	ns	
$I_{OCP}$	Overcurrent protect level	1.5	3	4.5	A	
$t_{OCP}$	Overcurrent protect trip time	2.5			$\mu\text{s}$	
$t_{MD}$	Mixed decay percentage	Measured from beginning of PWM cycle		75	%	
<b>CURRENT CONTROL</b>						
$I_{REF}$	xVREF input current	$xVREF = 3.3\text{ V}$		-3	3 $\mu\text{A}$	
$\Delta I_{CHOP}$	Chopping current accuracy	$xVREF = 2.5\text{ V}$ , derived from V3P3; 71% - 100% current		-5	5	%
		$xVREF = 2.5\text{ V}$ , derived from V3P3; 20% - 56% current		-10	10	

(1) Factory option 100 kHz.

 (2) Factory options for 2.5  $\mu\text{s}$ , 5  $\mu\text{s}$  or 6.25  $\mu\text{s}$ .

### TIMING REQUIREMENTS

over operating free-air temperature range (unless otherwise noted)

			MIN	MAX	UNIT
1	$t_{CYC}$	Clock cycle time	62		ns
2	$t_{CLKH}$	Clock high time	25		ns
3	$t_{CLKL}$	Clock low time	25		ns
4	$t_{SU(SDATA)}$	Setup time, SDATA to SCLK	5		ns
5	$t_{H(DATA)}$	Hold time, SDATA to SCLK	1		ns
6	$t_{SU(SCS)}$	Setup time, SCS to SCLK	5		ns
7	$t_{H(SCS)}$	Hold time, SCS to SCLK	1		ns

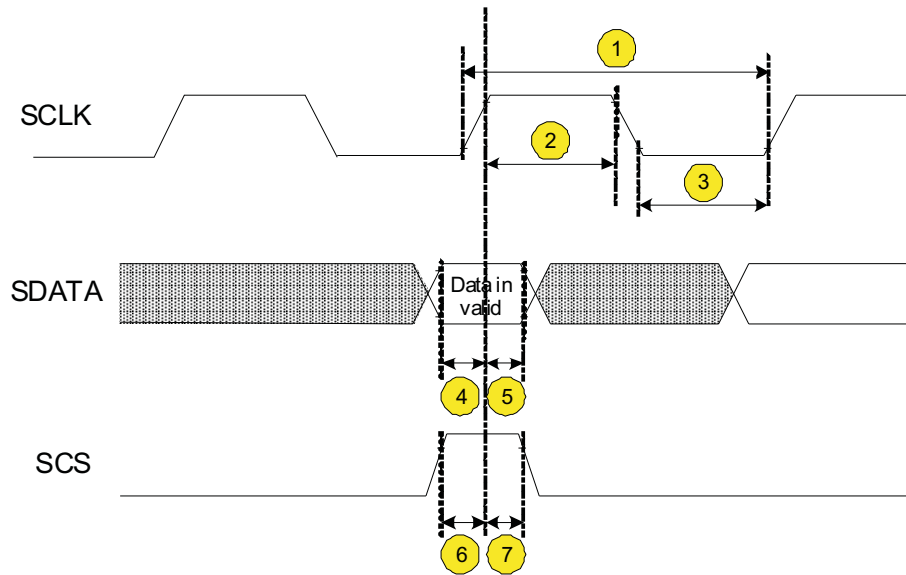

## FUNCTIONAL DESCRIPTION

### PWM Motor Drivers

The DRV8823 contains four H-bridge motor drivers with current-control PWM circuitry. A block diagram showing drivers A and B of the motor control circuitry (as typically used to drive a bipolar stepper motor) is shown below. Drivers C and D are the same as A and B (though the rds(on) of the output FETs is different).

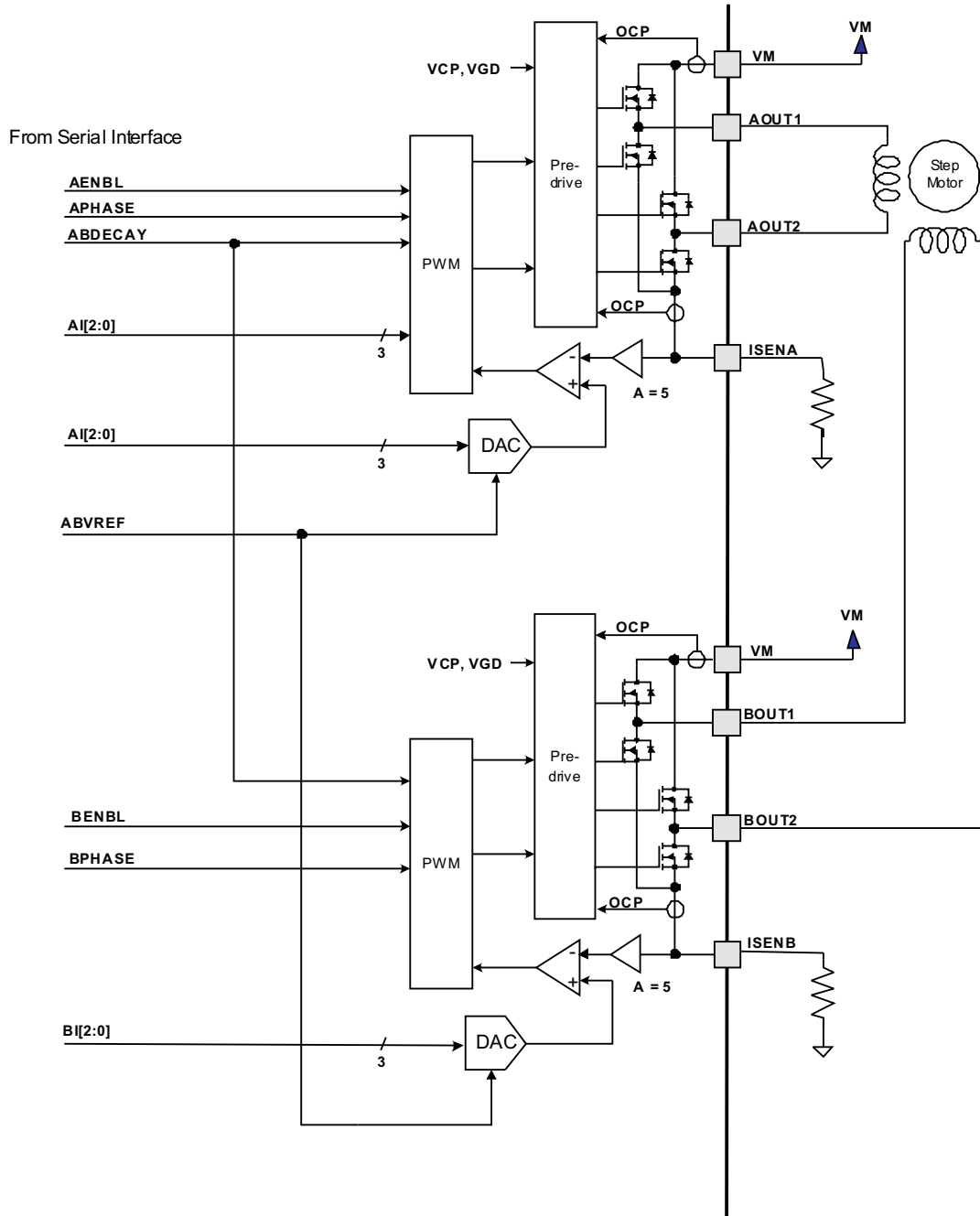

Figure 2. Block Diagram

Note that there are multiple VM motor power supply pins. All VM pins must be connected together to the motor supply voltage.

## Bridge Control

The xENBL bits in the serial interface registers enable current flow in each H-bridge when set to "1".

The xPHASE bits in the serial interface registers control the direction of current flow through each H-bridge. The following table shows the logic:

xPHASE	xOUT1	xOUT2
1	H	L
0	L	H

## Current Regulation

The motor driver employs fixed-frequency PWM current regulation (also called "current chopping"). When a winding is activated, the current through it rises until it reaches a threshold, then the current is switched off until the next PWM period.

The PWM frequency is fixed at 50 kHz. It may also be set to 100 kHz via factory option.

The PWM chopping current is set by a comparator which compares the voltage across a current sense resistor connected to the xISEN pins, multiplied by a factor of 5, with a reference voltage. The reference voltage is input from the VREF pin.

The full-scale (100%) chopping current is calculated as follows:

$$I_{CHOP} = \frac{V_{REFX}}{5 \cdot R_{ISENSE}} \quad (1)$$

Example:

If a 0.5-Ω sense resistor is used and the VREFx pin is 2.5 V, the full-scale (100%) chopping current is 2.5 V/(5 \* 0.5 Ω) = 1 A.

Three serial interface register bits per H-bridge (xI2, xI1 and xI0) are used to scale the current in each bridge as a percentage of the full-scale current set by the VREF input pin and sense resistance. The function of the bits is shown below:

xI2	xI1	xI0	Relative Current (% full-scale chopping current)
0	0	0	20
0	0	1	38
0	1	0	56
0	1	1	71
1	0	0	83
1	0	1	92
1	1	0	98
1	1	1	100

## Blanking Time

After the current is enabled in an H-bridge, the voltage on the xISEN pin is ignored for a fixed period of time before enabling the current sense circuitry. This blanking time is fixed at 3.75 μs. Note that the blanking time also sets the minimum on time of the PWM.



## Decay Mode

During PWM current chopping, the H-bridge is enabled to drive through the motor winding until the PWM current chopping threshold is reached. This is shown in Figure 3 as case 1. The current flow direction shown indicates positive current flow in the step table below.

Once the chopping current threshold is reached, the H-bridge can operate in two different states, fast decay or slow decay.

In fast decay mode, once the PWM chopping current level has been reached, the H-bridge reverses state to allow winding current to flow in a reverse direction. As the winding current approaches zero, the bridge is disabled to prevent any reverse current flow. Fast-decay mode is shown in Figure 3 as case 2.

In slow-decay mode, winding current is re-circulated by enabling both of the low-side FETs in the bridge. This is shown in Figure 3 as case 3.

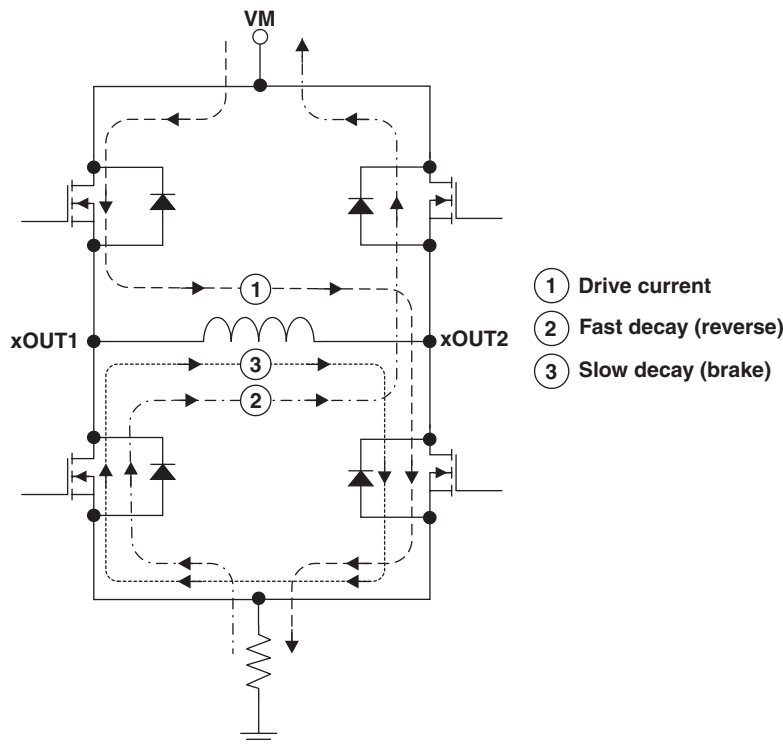

Figure 3. Decay Mode

The DRV8823 supports slow decay and also a mixed decay mode. Mixed decay mode begins as fast decay, but at a fixed period of time (75% of the PWM cycle) switches to slow decay mode for the remainder of the fixed PWM period.

Slow or mixed decay mode is selected by the state of the xDECAY bits in the serial interface registers. If the xDECAY bit is 0, slow decay is selected. If the xDECAY bit is 1, mixed decay is selected.

[查询 DRV8823 供应链](#)

## Protection Circuits

The DRV8823 is fully protected against undervoltage, overcurrent and overtemperature events.

### Overcurrent Protection (OCP)

All of the drivers in DRV8823 are protected with an OCP (Over-Current Protection) circuit.

The OCP circuit includes an analog current limit circuit, which acts by removing the gate drive from each output FET if the current through it exceeds a preset level. This circuit will limit the current to a level that is safe to prevent damage to the FET.

A digital circuit monitors the analog current limit circuits. If any analog current limit condition exists for longer than a preset period, all drivers in the device will be disabled.

The device is re-enabled upon the removal and re-application of power at the VM pins.

### Thermal Shutdown (TSD)

If the die temperature exceeds safe limits, all drivers in the device will be shut down.

The device will remain disabled until the die temperature has fallen to a safe level. After the temperature has fallen, the device may be re-enabled upon the removal and re-application of power at the VM pin.

### Undervoltage Lockout (UVLO)

If at any time the voltage on the VM pins falls below the undervoltage lockout threshold voltage, all circuitry in the device will be disabled. Operation will resume when VM rises above the UVLO threshold. The indexer logic will be reset to its initial condition in the event of an undervoltage lockout.

### Shoot-Through Current Prevention

The gate drive to each FET in the H-bridge is controlled to prevent any cross-conduction (shoot through current) during transitions.

### Serial Data Transmission

Data transfers consist of sixteen bits of serial data, shifted into the SDATA pin LSB first.

On serial writes to DRV8823, additional clock edges following the final data bit will continue to shift data bits into the data register; therefore, the last 16 bits presented will be latched and used.

One of two registers is selected by setting bits in an address field in the four upper bits in the serial data transferred (ADDR in the tables below). One 16-bit register is used to control motor #1 (bridges A & B), and a second 16-bit register is used to control motor 2 (bridges C & D).

Data can only be transferred into the serial interface if the SCS input pin is active high.

Data is initially clocked in to a temporary holding register. This data is latched into the motor driver on the rising edge of the SSTB pin. If the SSTB pin is tied high at all times, the data will be latched in after all 16 bits have been transferred.

**Data Format**
**Table 1. Motor 1 Command (Bridges A & B)**

Bit	D15 - D12	D11	D10	D9	D8	D7	D6	D5	D4	D3	D2	D1	D0
<b>Name</b>	ADDR (= 0000)	BDECAY	B12	B11	B10	BPHASE	BENBL	ADECAY	A12	A11	A10	APHASE	AENBL
<b>Reset Value</b>	x	0	0	0	0	0	0	0	0	0	0	0	0

**Table 2. Motor 2 Command (Bridges C & D)**

Bit	D15 - D12	D11	D10	D9	D8	D7	D6	D5	D4	D3	D2	D1	D0
<b>Name</b>	ADDR (= 0001)	DDECAY	D12	D11	D10	DPHASE	DENBL	CDECAY	C12	C11	C10	CPHASE	CENBL
<b>Reset Value</b>	x	0	0	0	0	0	0	0	0	0	0	0	0

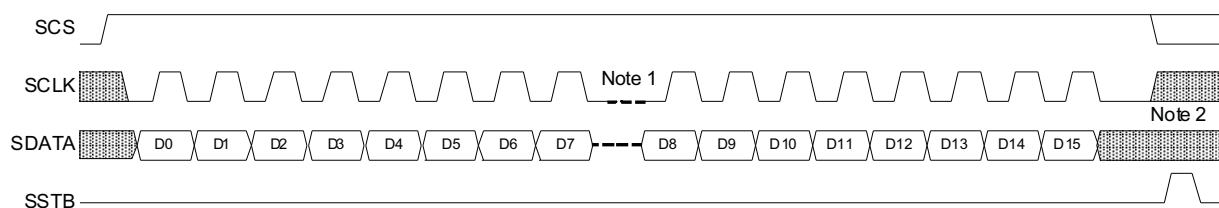
**Serial Data Timing**

**Figure 4. Serial Data Timing Diagram**

Note 1: Any amount of time is allowed between clocks, or groups of clocks, as long as SCS stays active. This allows 8- or 16-bit transfers.

Note 2: If more than 16 clock edges are presented while transferring data (while SCS is still high), data will continue to be shifted into the data register.

## THERMAL INFORMATION

### Thermal Protection

The DRV8823 has thermal shutdown (TSD) as described above. If the die temperature exceeds approximately 150°C, the device will be disabled until the temperature drops to a safe level.

Any tendency of the device to enter thermal shutdown is an indication of either excessive power dissipation, insufficient heatsinking, or too high an ambient temperature.

### Power Dissipation

Power dissipation in the DRV8823 is dominated by the power dissipated in the output FET resistance, or  $R_{DS(ON)}$ . Average power dissipation when running a stepper motor can be roughly estimated by [Equation 2](#).

$$P_{TOT} = 4 \cdot R_{DS(ON)} \cdot (I_{OUT(RMS)})^2 \quad (2)$$

where  $P_{TOT}$  is the total power dissipation,  $R_{DS(ON)}$  is the resistance of each FET, and  $I_{OUT(RMS)}$  is the RMS output current being applied to each winding.  $I_{OUT(RMS)}$  is equal to the approximately 0.7x the full-scale output current setting. The factor of 4 comes from the fact that there are two motor windings, and at any instant two FETs are conducting winding current for each winding (one high-side and one low-side). Remember that the DRV8823 has two stepper motor drivers, so the power dissipation of each must be added together to determine the total device power dissipation.

The maximum amount of power that can be dissipated in the DRV8823 is dependent on ambient temperature and heatsinking. The thermal dissipation ratings table in the datasheet can be used to estimate the temperature rise for typical PCB constructions.

Note that  $R_{DS(ON)}$  increases with temperature, so as the device heats, the power dissipation increases. This must be taken into consideration when sizing the heatsink.

### Heatsinking

The PowerPAD™ package uses an exposed pad to remove heat from the device. For proper operation, this pad must be thermally connected to copper on the PCB to dissipate heat. On a multi-layer PCB with a ground plane, this can be accomplished by adding a number of vias to connect the thermal pad to the ground plane. On PCBs without internal planes, copper area can be added on either side of the PCB to dissipate heat. If the copper area is on the opposite side of the PCB from the device, thermal vias are used to transfer the heat between top and bottom layers.

For details about how to design the PCB, refer to TI application report [SLMA002](#), "PowerPAD™ Thermally Enhanced Package" and TI application brief [SLMA004](#), "PowerPAD™ Made Easy", available at [www.ti.com](#).

In general, the more copper area that can be provided, the more power can be dissipated. [Figure 5](#) shows thermal resistance vs. copper plane area for both a single-sided PCB with 2-oz copper heatsink area, and a 4-layer PCB with 1-oz copper and a solid ground plane. Both PCBs are 76 mm x 114 mm, and 1.6 mm thick. It can be seen that the heatsink effectiveness increases rapidly to about 20 cm<sup>2</sup>, then levels off somewhat for larger areas.

Six pins on the center of each side of the package are also connected to the device ground. A copper area can be used on the PCB that connects to the PowerPAD™ as well as to all the ground pins on each side of the device. This is especially useful for single-layer PCB designs.

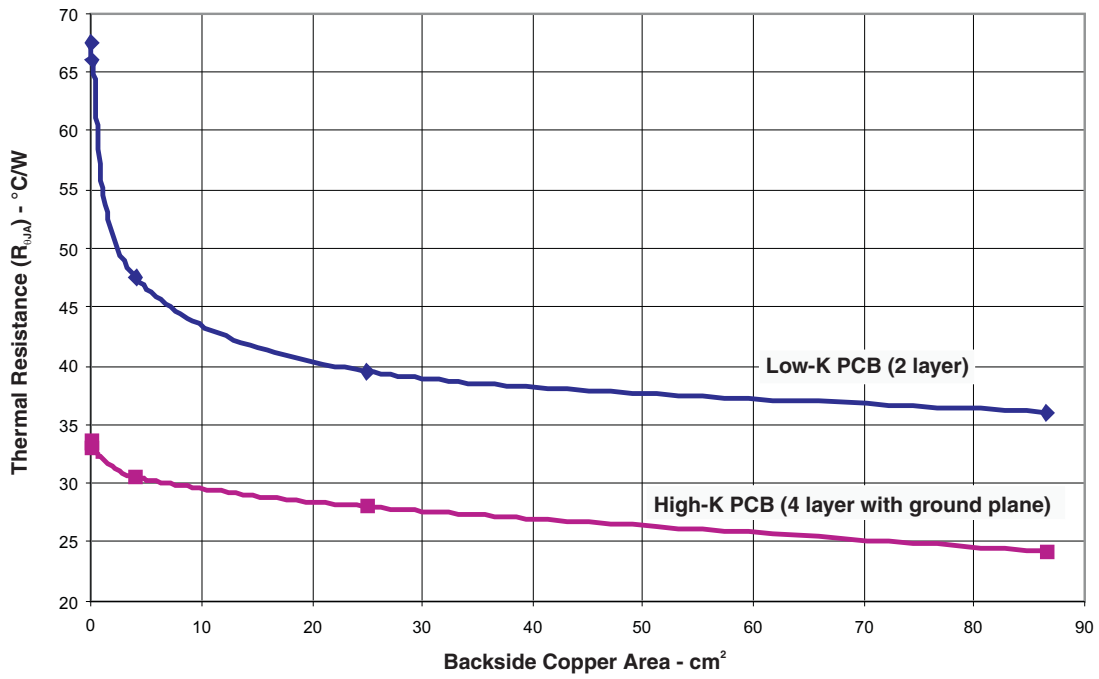

Figure 5. Thermal Resistance vs. Copper Plane Area

**PACKAGING INFORMATION**

Orderable Device	Status <sup>(1)</sup>	Package Type	Package Drawing	Pins	Package Qty	Eco Plan <sup>(2)</sup>	Lead/Ball Finish	MSL Peak Temp <sup>(3)</sup>
DRV8823DCA	ACTIVE	HTSSOP	DCA	48	40	Green (RoHS & no Sb/Br)	CU NIPDAU	Level-3-260C-168 HR
DRV8823DCAR	ACTIVE	HTSSOP	DCA	48	2000	Green (RoHS & no Sb/Br)	CU NIPDAU	Level-3-260C-168 HR

<sup>(1)</sup> The marketing status values are defined as follows:

**ACTIVE:** Product device recommended for new designs.

**LIFEBUY:** TI has announced that the device will be discontinued, and a lifetime-buy period is in effect.

**NRND:** Not recommended for new designs. Device is in production to support existing customers, but TI does not recommend using this part in a new design.

**PREVIEW:** Device has been announced but is not in production. Samples may or may not be available.

**OBsolete:** TI has discontinued the production of the device.

<sup>(2)</sup> Eco Plan - The planned eco-friendly classification: Pb-Free (RoHS), Pb-Free (RoHS Exempt), or Green (RoHS & no Sb/Br) - please check <http://www.ti.com/productcontent> for the latest availability information and additional product content details.

**TBD:** The Pb-Free/Green conversion plan has not been defined.

**Pb-Free (RoHS):** TI's terms "Lead-Free" or "Pb-Free" mean semiconductor products that are compatible with the current RoHS requirements for all 6 substances, including the requirement that lead not exceed 0.1% by weight in homogeneous materials. Where designed to be soldered at high temperatures, TI Pb-Free products are suitable for use in specified lead-free processes.

**Pb-Free (RoHS Exempt):** This component has a RoHS exemption for either 1) lead-based flip-chip solder bumps used between the die and package, or 2) lead-based die adhesive used between the die and leadframe. The component is otherwise considered Pb-Free (RoHS compatible) as defined above.

**Green (RoHS & no Sb/Br):** TI defines "Green" to mean Pb-Free (RoHS compatible), and free of Bromine (Br) and Antimony (Sb) based flame retardants (Br or Sb do not exceed 0.1% by weight in homogeneous material)

<sup>(3)</sup> MSL, Peak Temp. -- The Moisture Sensitivity Level rating according to the JEDEC industry standard classifications, and peak solder temperature.

**Important Information and Disclaimer:**The information provided on this page represents TI's knowledge and belief as of the date that it is provided. TI bases its knowledge and belief on information provided by third parties, and makes no representation or warranty as to the accuracy of such information. Efforts are underway to better integrate information from third parties. TI has taken and continues to take reasonable steps to provide representative and accurate information but may not have conducted destructive testing or chemical analysis on incoming materials and chemicals. TI and TI suppliers consider certain information to be proprietary, and thus CAS numbers and other limited information may not be available for release.

In no event shall TI's liability arising out of such information exceed the total purchase price of the TI part(s) at issue in this document sold by TI to Customer on an annual basis.

**TAPE AND REEL INFORMATION**

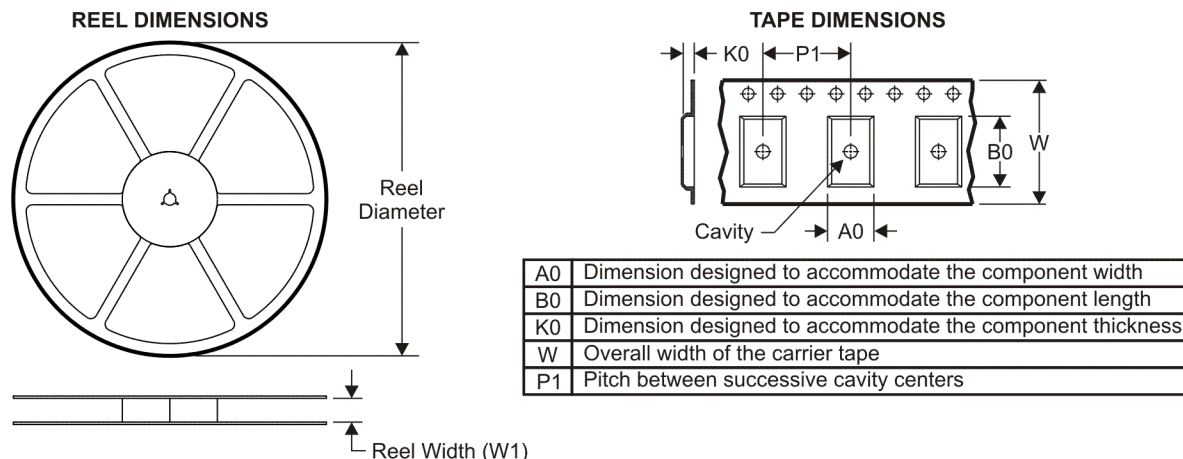

**QUADRANT ASSIGNMENTS FOR PIN 1 ORIENTATION IN TAPE**

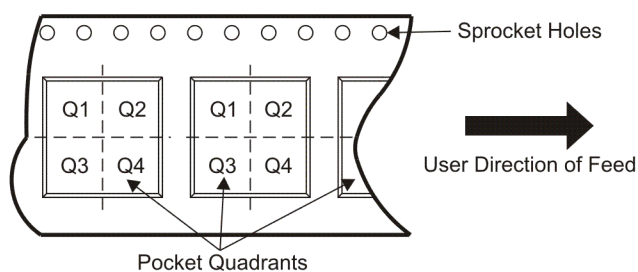

\*All dimensions are nominal

Device	Package Type	Package Drawing	Pins	SPQ	Reel Diameter (mm)	Reel Width W1 (mm)	A0 (mm)	B0 (mm)	K0 (mm)	P1 (mm)	W (mm)	Pin1 Quadrant
DRV8823DCAR	HTSSOP	DCA	48	2000	330.0	24.4	8.6	15.8	1.8	12.0	24.0	Q1

**TAPE AND REEL BOX DIMENSIONS**



\*All dimensions are nominal

Device	Package Type	Package Drawing	Pins	SPQ	Length (mm)	Width (mm)	Height (mm)
DRV8823DCAR	HTSSOP	DCA	48	2000	346.0	346.0	41.0



DCA (R-PDSO-G48)

PowerPAD™ PLASTIC SMALL-OUTLINE

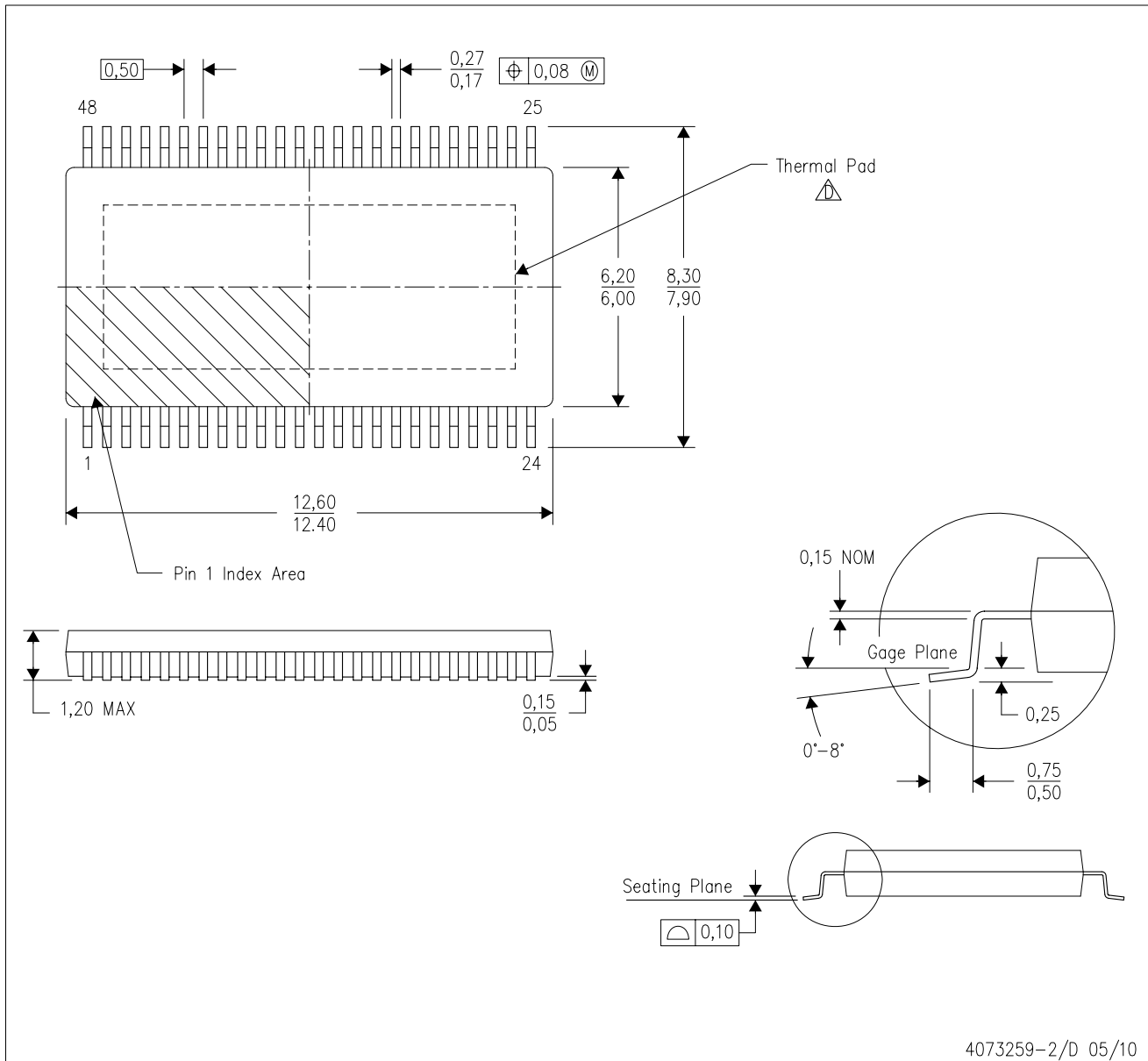

- NOTES:
- All linear dimensions are in millimeters. Dimensioning and tolerancing per ASME Y14.5M-1994.
  - This drawing is subject to change without notice.
  - Body dimensions do not include mold flash or protrusion not to exceed 0,15.
  - This package is designed to be soldered to a thermal pad on the board. Refer to Technical Brief, PowerPad Thermally Enhanced Package, Texas Instruments Literature No. SLMA002 for information regarding recommended board layout. This document is available at [www.ti.com](http://www.ti.com) <<http://www.ti.com>>.
  - Falls within JEDEC MO-153

PowerPAD is a trademark of Texas Instruments.

THERMAL INFORMATION

This PowerPAD™ package incorporates an exposed thermal pad that is designed to be attached to a printed circuit board (PCB). The thermal pad must be soldered directly to the PCB. After soldering, the PCB can be used as a heatsink. In addition, through the use of thermal vias, the thermal pad can be attached directly to the appropriate copper plane shown in the electrical schematic for the device, or alternatively, can be attached to a special heatsink structure designed into the PCB. This design optimizes the heat transfer from the integrated circuit (IC).

For additional information on the PowerPAD package and how to take advantage of its heat dissipating abilities, refer to Technical Brief, PowerPAD Thermally Enhanced Package, Texas Instruments Literature No. SLMA002 and Application Brief, PowerPAD Made Easy, Texas Instruments Literature No. SLMA004. Both documents are available at [www.ti.com](http://www.ti.com).

The exposed thermal pad dimensions for this package are shown in the following illustration.

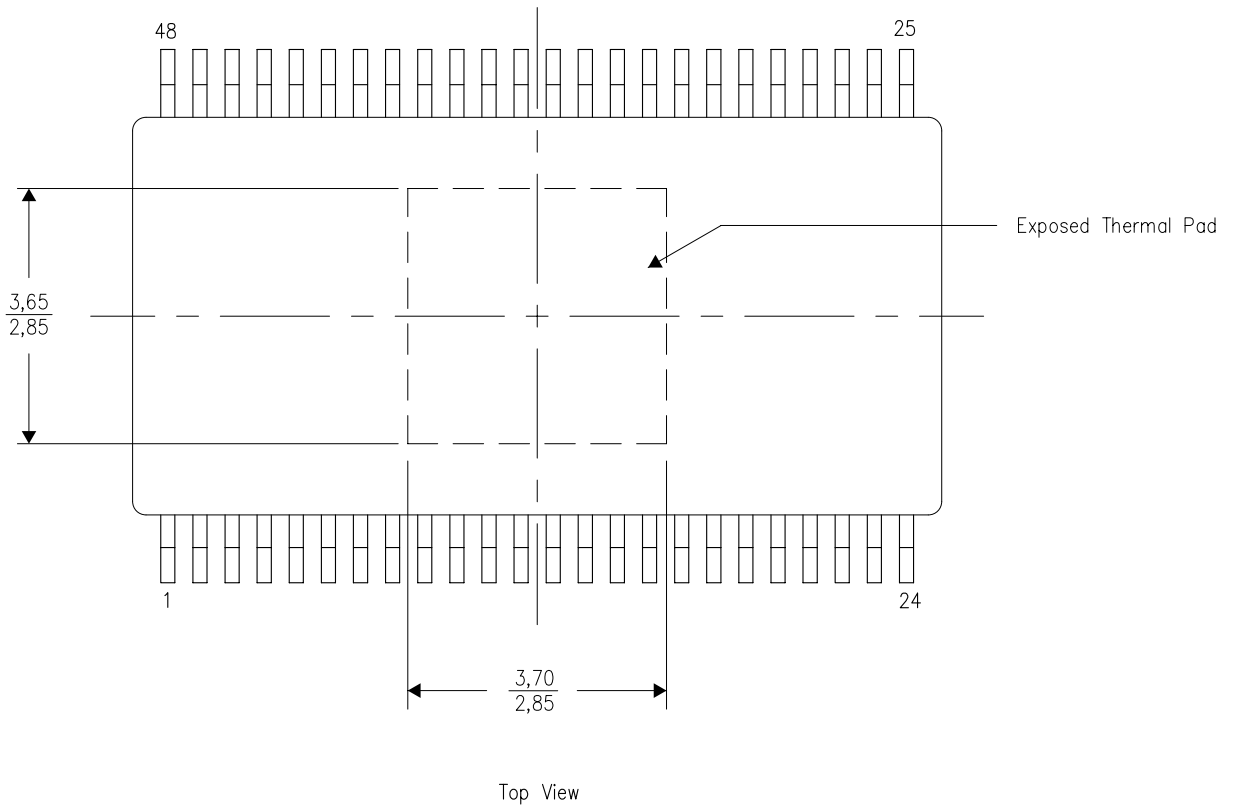

NOTE: All linear dimensions are in millimeters

Exposed Thermal Pad Dimensions

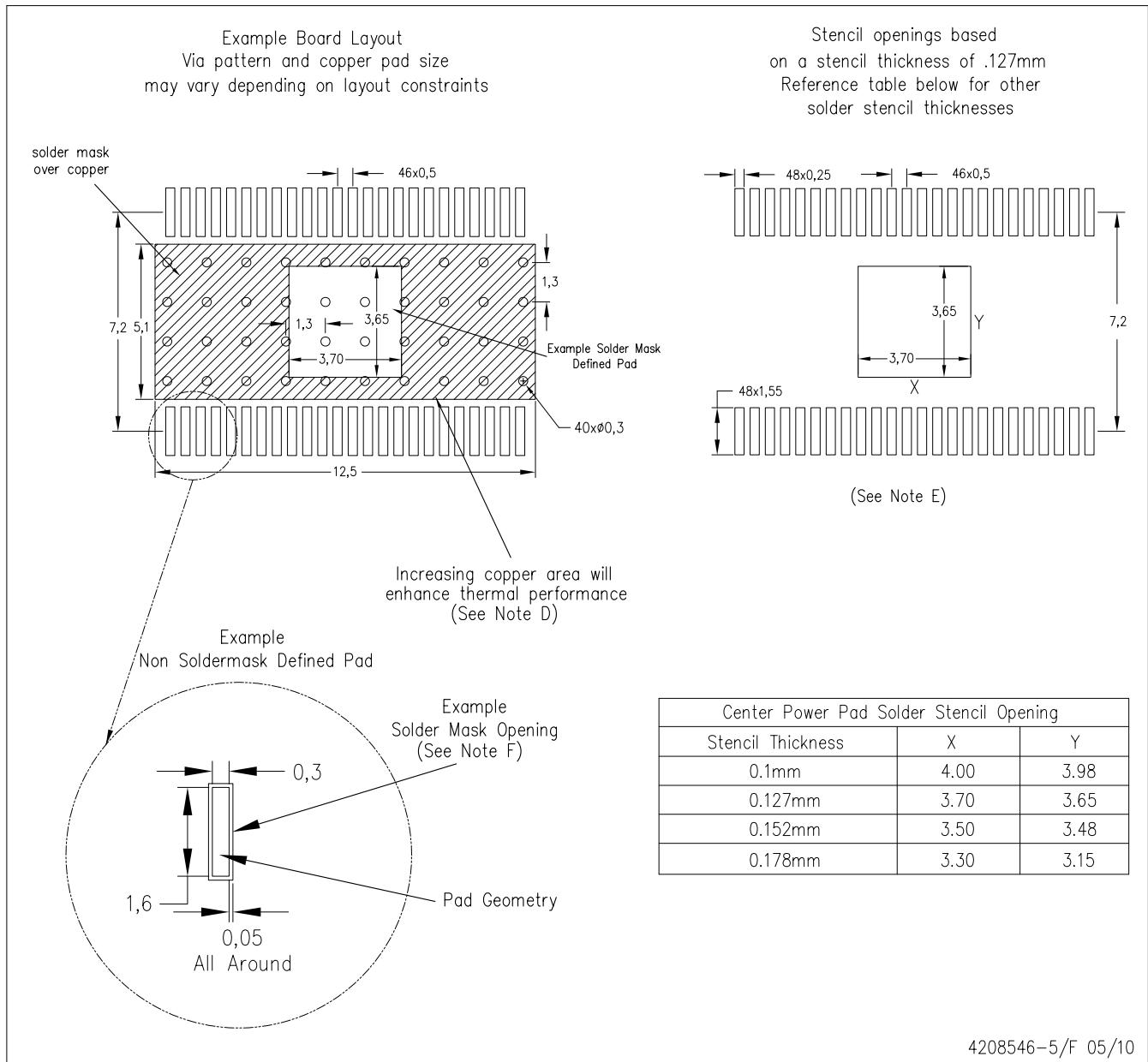

- NOTES:
- A. All linear dimensions are in millimeters.
  - B. This drawing is subject to change without notice.
  - C. Customers should place a note on the circuit board fabrication drawing not to alter the center solder mask defined pad.
  - D. This package is designed to be soldered to a thermal pad on the board. Refer to Technical Brief, PowerPAD Thermally Enhanced Package, Texas Instruments Literature No. SLMA002, SLMA004, and also the Product Data Sheets for specific thermal information, via requirements, and recommended board layout. These documents are available at [www.ti.com](http://www.ti.com) <<http://www.ti.com>>. Publication IPC-7351 is recommended for alternate designs.
  - E. Laser cutting apertures with trapezoidal walls and also rounding corners will offer better paste release. Customers should contact their board assembly site for stencil design recommendations. Example stencil design based on a 50% volumetric metal load solder paste. Refer to IPC-7525 for other stencil recommendations.
  - F. Customers should contact their board fabrication site for solder mask tolerances between and around signal pads.

## IMPORTANT NOTICE

Texas Instruments Incorporated and its subsidiaries (TI) reserve the right to make corrections, modifications, enhancements, improvements, and other changes to its products and services at any time and to discontinue any product or service without notice. Customers should obtain the latest relevant information before placing orders and should verify that such information is current and complete. All products are sold subject to TI's terms and conditions of sale supplied at the time of order acknowledgment.

TI warrants performance of its hardware products to the specifications applicable at the time of sale in accordance with TI's standard warranty. Testing and other quality control techniques are used to the extent TI deems necessary to support this warranty. Except where mandated by government requirements, testing of all parameters of each product is not necessarily performed.

TI assumes no liability for applications assistance or customer product design. Customers are responsible for their products and applications using TI components. To minimize the risks associated with customer products and applications, customers should provide adequate design and operating safeguards.

TI does not warrant or represent that any license, either express or implied, is granted under any TI patent right, copyright, mask work right, or other TI intellectual property right relating to any combination, machine, or process in which TI products or services are used. Information published by TI regarding third-party products or services does not constitute a license from TI to use such products or services or a warranty or endorsement thereof. Use of such information may require a license from a third party under the patents or other intellectual property of the third party, or a license from TI under the patents or other intellectual property of TI.

Reproduction of TI information in TI data books or data sheets is permissible only if reproduction is without alteration and is accompanied by all associated warranties, conditions, limitations, and notices. Reproduction of this information with alteration is an unfair and deceptive business practice. TI is not responsible or liable for such altered documentation. Information of third parties may be subject to additional restrictions.

Resale of TI products or services with statements different from or beyond the parameters stated by TI for that product or service voids all express and any implied warranties for the associated TI product or service and is an unfair and deceptive business practice. TI is not responsible or liable for any such statements.

TI products are not authorized for use in safety-critical applications (such as life support) where a failure of the TI product would reasonably be expected to cause severe personal injury or death, unless officers of the parties have executed an agreement specifically governing such use. Buyers represent that they have all necessary expertise in the safety and regulatory ramifications of their applications, and acknowledge and agree that they are solely responsible for all legal, regulatory and safety-related requirements concerning their products and any use of TI products in such safety-critical applications, notwithstanding any applications-related information or support that may be provided by TI. Further, Buyers must fully indemnify TI and its representatives against any damages arising out of the use of TI products in such safety-critical applications.

TI products are neither designed nor intended for use in military/aerospace applications or environments unless the TI products are specifically designated by TI as military-grade or "enhanced plastic." Only products designated by TI as military-grade meet military specifications. Buyers acknowledge and agree that any such use of TI products which TI has not designated as military-grade is solely at the Buyer's risk, and that they are solely responsible for compliance with all legal and regulatory requirements in connection with such use.

TI products are neither designed nor intended for use in automotive applications or environments unless the specific TI products are designated by TI as compliant with ISO/TS 16949 requirements. Buyers acknowledge and agree that, if they use any non-designated products in automotive applications, TI will not be responsible for any failure to meet such requirements.

Following are URLs where you can obtain information on other Texas Instruments products and application solutions:

<b>Products</b>		<b>Applications</b>	
Amplifiers	<a href="http://amplifier.ti.com">amplifier.ti.com</a>	Audio	<a href="http://www.ti.com/audio">www.ti.com/audio</a>
Data Converters	<a href="http://dataconverter.ti.com">dataconverter.ti.com</a>	Automotive	<a href="http://www.ti.com/automotive">www.ti.com/automotive</a>
DLP® Products	<a href="http://www.dlp.com">www.dlp.com</a>	Communications and Telecom	<a href="http://www.ti.com/communications">www.ti.com/communications</a>
DSP	<a href="http://dsp.ti.com">dsp.ti.com</a>	Computers and Peripherals	<a href="http://www.ti.com/computers">www.ti.com/computers</a>
Clocks and Timers	<a href="http://www.ti.com/clocks">www.ti.com/clocks</a>	Consumer Electronics	<a href="http://www.ti.com/consumer-apps">www.ti.com/consumer-apps</a>
Interface	<a href="http://interface.ti.com">interface.ti.com</a>	Energy	<a href="http://www.ti.com/energy">www.ti.com/energy</a>
Logic	<a href="http://logic.ti.com">logic.ti.com</a>	Industrial	<a href="http://www.ti.com/industrial">www.ti.com/industrial</a>
Power Mgmt	<a href="http://power.ti.com">power.ti.com</a>	Medical	<a href="http://www.ti.com/medical">www.ti.com/medical</a>
Microcontrollers	<a href="http://microcontroller.ti.com">microcontroller.ti.com</a>	Security	<a href="http://www.ti.com/security">www.ti.com/security</a>
RFID	<a href="http://www.ti-rfid.com">www.ti-rfid.com</a>	Space, Avionics & Defense	<a href="http://www.ti.com/space-avionics-defense">www.ti.com/space-avionics-defense</a>
RF/IF and ZigBee® Solutions	<a href="http://www.ti.com/lprf">www.ti.com/lprf</a>	Video and Imaging	<a href="http://www.ti.com/video">www.ti.com/video</a>
		Wireless	<a href="http://www.ti.com/wireless-apps">www.ti.com/wireless-apps</a>