



# 1.25G SFP Transceiver

## MXP-243S

### Features:

- Operating bit rate 1.25Gb/s
- Operating at 1280-1330nm wavelength
- Single +3.3V power supply
- Differential LVPECL inputs and outputs
- TTL signal detect indicator
- Industry standard small form pluggable (SFP) package
- Hot-pluggable capability
- Duplex LC connector
- Metal enclosure, for lower EMI
- Very low jitter
- Low power dissipation
- Link length up to 20km in 9/125 SMF

### Applications:

- 1.25Gb/s 1000Base-LX Ethernet
- 1.0625Gb/s Fiber Channel

### Description

MXP-243S SFP transceiver is an excellent product , which is a series of high performance optical modules suitable for the Fiber optic communication and Ethernet accessing for signal that rates up to 1.25Gb/s.

The transmitter section of MXP-243S SFP incorporates 1310nm FP laser as the optical source. And the receiver section consists of a PIN photodiode mounted together with a trans-impedance preamplifier (TIA).

Because of its hot-pluggable capability , MXP-243S SFP transceiver can be installed in or removed from any MSA compliant pluggable small form factor port regardless of whether the host equipment is operating or not.

Furthermore , MXP-243S SFP transceiver features an E/EPROM that contains the detailed product's information stored for retrieval by host equipment. For further information, please refer to SFP Multi-Source Agreement (MSA).

The transceiver operates at up to 1.25G data-rate from a single +3.3 V power supply only. And it uses TTL signal as detect indicator.

### Specification:

#### Operating Information

Part Number	Input/Output	Signal Detect	Voltage	Temperature
MXP-243S	AC/AC	TTL	+3.3V	0 to 70

### Transmitter Optical, Electrical Characteristics

Parameter	Symbol	Min	Typ	Max	Unit	Note
Input differential impedance	$R_{in}$		100		$\Omega$	
Differential data input swing	$V_{in PP}$	100		1200	mV	
Transmit Disable Input High Voltage		2.0			V	
Transmit Disable Input Low Voltage				0.8	V	
Transmit Fault Output High Voltage		2.0			V	
Transmit Fault Output Low Voltage				0.8	V	
Transmit Disable Assert Time			0.14	5	$\mu s$	
Optical Transmit Power	$P_O$	-9.5		-3	dBm	Average Power
Extinction Ratio	ER	9			dB	
Output Spectrum Width(RMS)	$\Delta\lambda$			4	nm	

### Receiver Optical, Electrical Characteristics

Parameter	Symbol	Min	Typ	Max	Unit	Note
Single ended data output swing	$V_{out PP}$	200		800	mV	
Receiver Loss of Signal Output Voltage -high		2			V	
Receiver Loss of Signal Output Voltage -low				0.8	V	
Sensitivity	Sen			-20	dBm	BER<1E-10
Maximum Input Power	$P_{inMAX}$	-3			dBm	
Signal detect Range		-30		-21	dBm	
Signal detect-Hysteresis		0.5			dB	

### Absolute Maximum Ratings

Parameter	Symbol	Min	Max	Unit	Note
Storage Temperature	$T_S$	-40	+85		
Operating Temperature	$T_O$	0	+70		
Power Supply Voltage	$V_{CC}$	-0.5	6.0	V	

**Pin View :**

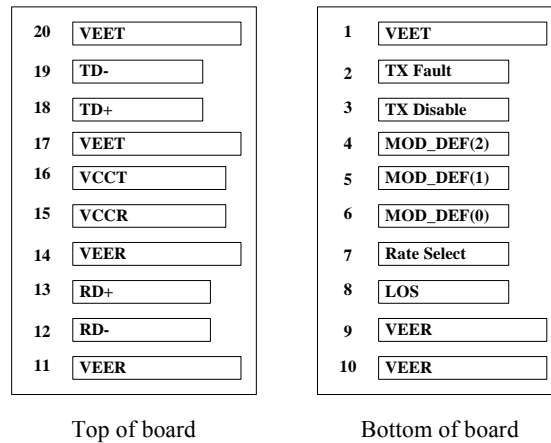

**Pin Assignment:**

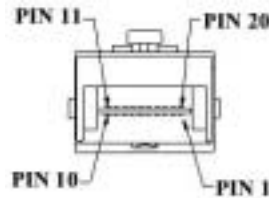

Pin	Name	Description
1	VEET	Transmitter Ground
2	TXFAULT	Transmitter Fault.
3	TXDIS	Transmitter Disable.
4	MOD_DEF(2)	SDA Serial Data Signal
5	MOD_DEF(1)	SCL Serial Clock Signal
6	MOD_DEF(0)	Grounded within the module.
7	Rate Select	No connection required
8	LOS	Loss of Signal indication. Logic 0 indicates normal operation.
9	VEER	Receiver Ground
10	VEER	Receiver Ground
11	VEER	Receiver Ground
12	RD-	Receiver Inverted DATA out.
13	RD+	Receiver Non-inverted DATA out.
14	VEER	Receiver Ground
15	VCCR	Receiver Power Supply
16	VCCT	Transmitter Power Supply
17	VEET	Transmitter Ground
18	TD+	Transmitter Non-Inverted DATA in.
19	TD-	Transmitter Inverted DATA in.
20	VEET	Transmitter Ground

## Block Diagram Of Transceiver

### Transmitter Section

The transmitter section consists of 1310nm FP laser in an eye safe optical subassembly (OSA) which mates to the fiber cable. The laser OSA is driven by a LD driver IC which converts differential input LVPECL logic signals into an analog laser driving current.

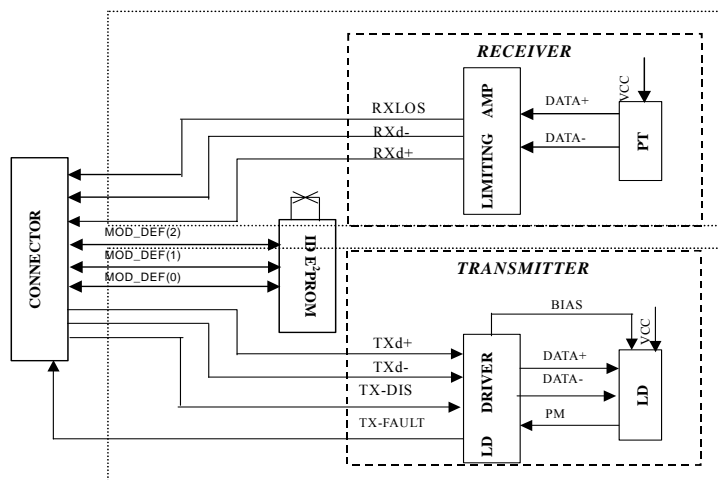

### TX-FAULT

TX Fault is an open collector/drain output, which should be pulled up with a 4.7K – 10KΩ resistor on the host board. Pull up voltage between 2.0V and VccT, R+0.3V. When high, output indicates a laser fault of some kind. Low indicates normal operation. In the low state, the output will be pulled to < 0.8V.

When sensing an improper power level in the laser driver, the SFP sets this signal high and turns off the laser. TX-FAULT can be reset with the TX-DISABLE line. The signal is in TTL level.

### TX-DISABLE

TX disable is an input that is used to shut down the transmitter optical output. It is pulled up within the module with a 4.7 – 10 KΩ resistor. Its states are: Low (0 – 0.8V): Transmitter on; (>0.8, < 2.0V): Undefined; High (2.0 – 3.465V): Transmitter Disabled; Open: Transmitter Disabled. The TX-DISABLE signal is high (TTL logic “1”) to turn off the laser output. The laser will turn on when TX-DISABLE is low (TTL logic “0”).

### TD-/+

These are the differential transmitter inputs. They are AC-coupled, differential lines with 100Ω differential termination inside the module. The AC coupling is done inside the module and is thus not required on the host board. The inputs will accept differential swings of 500 – 2400 mV (250 – 1200 mV single-ended), though it is recommended that values between 500 and 1200 mV differential (250 – 600 mV single-ended) be used for best EMI performance.

### Receiver Section

The receiver utilizes an InGaAs PIN photodiode mounted together with a trans-impedance preamplifier IC in an OSA. This OSA is connected to a circuit providing post-amplification quantization, and optical signal detection.

### RX-LOS

LOS (Loss of Signal) is an open collector/drain output, which should be pulled up with a 4.7K – 10KΩ resistor. Pull up voltage between 2.0V and VccT, R+0.3V. When high, this output indicates the received optical power is below the worst-case receiver sensitivity (as defined by the standard in use). Low indicates normal operation. In the low state, the output will be pulled to < 0.8V.

The RX-LOS is high (TTL logic “1”) when there is no incoming light from the companion transceiver. This signal is normally used by the system for the diagnostic purpose. The signal is operated in TTL level.

### RD-/+

These are the differential receiver outputs. They are AC coupled 100Ω differential lines which should be terminated with 100 Ω(differential) at the user SERDES. The AC coupling is done inside the module and is thus not required on the host board. The voltage swing on these lines will be between 370 and 2000 mV differential (185 – 1000 mV single ended) when properly terminated.

### Recommended Interface Circuit

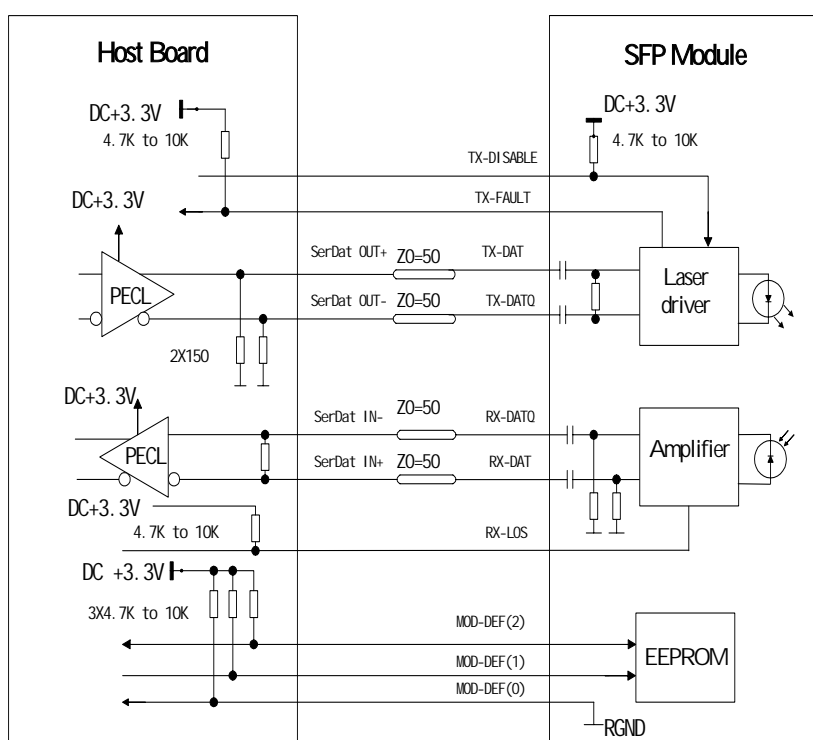

### Dimensions

Dimensions are in millimeters. All dimensions are  $\pm 0.1\text{mm}$  unless otherwise specified. (unit:mm).

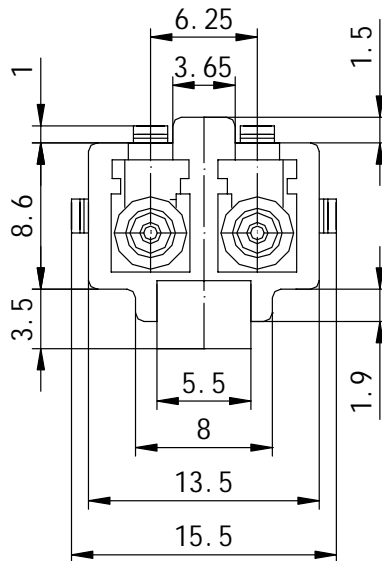
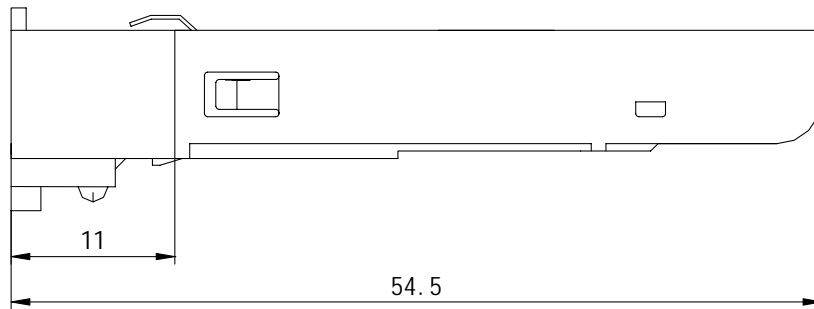
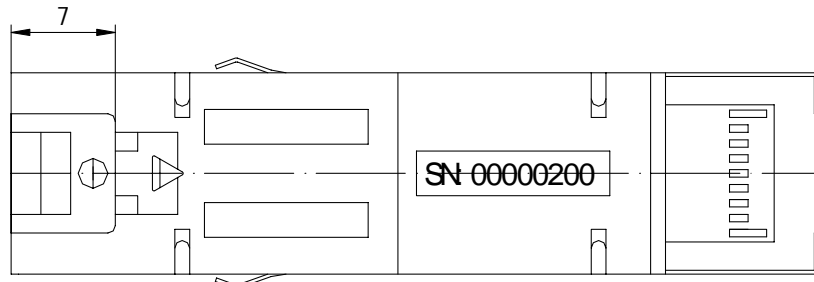

## Digital transceiver module

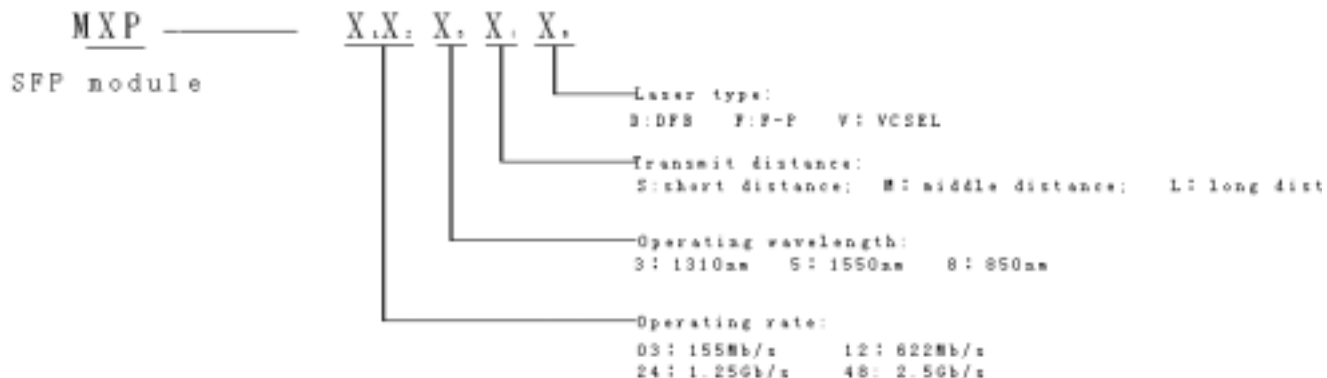

### Statement:

- Genuine-optical company has the ultimate explanation authority to the content of the product material, if there have some modifies, we're sorry for can't give a notice.
- Users should for our company on their one's own uses performance should having prove going on of products, our company is not responsible for performance of user's products . Any standard , agreement that this text quotes are only for referential use, do not do the basis of examining the quality of the products , whether the products are qualified to produce factory's test stone to fix with our company.

Version: **V2.1**

Publishing Date: 2005-04-28

### Contact Information:

Address: Huagong Tech BDG, Science &Technology Region of Hust,

Donghu High-Tech Zone, Wuhan Hubei, P.R.China

Post Code: 430223

Tel: +86-27-87180097

Website: <http://www.genuine-opto.com>