

## **±2.5 V / 5 V, 200 kSps, 16-bit, High-throughput $\Delta\Sigma$ ADC**

### Features

- ❑ Single-ended Analog Input
- ❑ On-chip Buffers for High Input Impedance
- ❑ Conversion Time = 5  $\mu$ S
- ❑ Settles in One Conversion
- ❑ Linearity Error = 0.0007%
- ❑ Signal-to-Noise = 81 dB
- ❑ S/(N + D) = 81 dB
- ❑ DNL =  $\pm 0.1$  LSB Max.
- ❑ Self-calibration:
  - Maintains accuracy over time & temperature.
- ❑ Simple three/four-wire serial interface
- ❑ Power Supply Configurations:
  - Analog: +5V/GND; IO: +1.8V to +3.3V
  - Analog:  $\pm 2.5$ V; IO: +1.8V to +3.3V
- ❑ Power Consumption:
  - ADC Input Buffers On: 85 mW
  - ADC Input Buffers Off: 60 mW

### General Description

The CS5581 is a single-channel, 16-bit analog-to-digital converter capable of 200 kSps conversion rate. The input accepts a single-ended analog input signal. On-chip buffers provide high input impedance for both the AIN input and the VREF+ input. This significantly reduces the drive requirements of signal sources and reduces errors due to source impedances. The CS5581 is a delta-sigma converter capable of switching multiple input channels at a high rate with no loss in throughput. The ADC uses a low-latency digital filter architecture. The filter is designed for fast settling and settles to full accuracy in one conversion. The converter's 16-bit data output is in serial format, with the serial port acting as either a master or a slave. The converter is designed to support bipolar, ground-referenced signals when operated from  $\pm 2.5$ V analog supplies.

The CS5581 uses self-calibration to achieve low offset and gain errors. The converter achieves a S/N of 81 dB. Linearity is 0.0007% of full scale.

The converter can operate from an analog supply of 0-5V or from  $\pm 2.5$ V. The digital interface supports standard logic operating from 1.8, 2.5, or 3.3 V.

### ORDERING INFORMATION:

See [Ordering Information](#) on page 31.

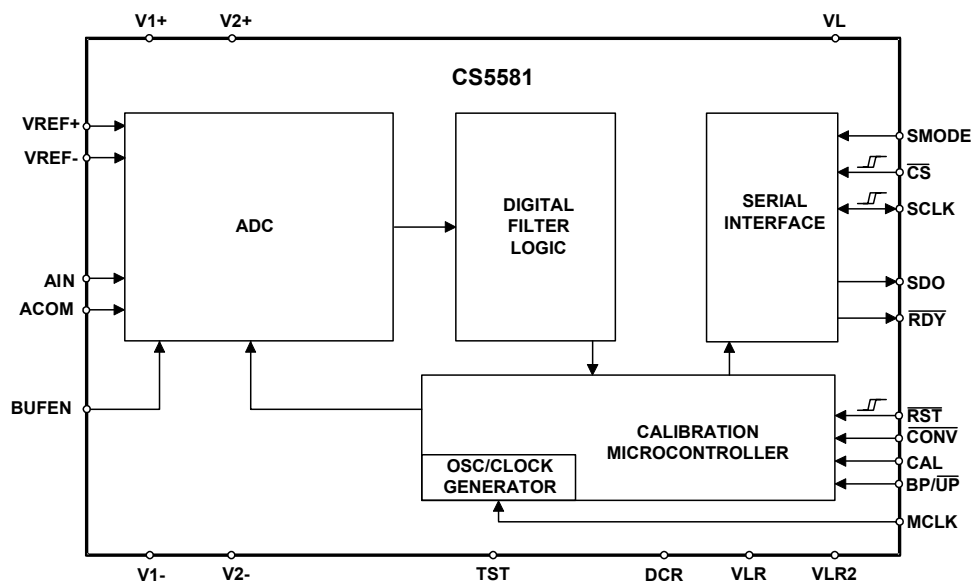

### Advance Product Information

This document contains information for a new product. Cirrus Logic reserves the right to modify this product without notice.

**TABLE OF CONTENTS**

<b>1. CHARACTERISTICS AND SPECIFICATIONS</b> .....	<b>4</b>
ANALOG CHARACTERISTICS .....	4
SWITCHING CHARACTERISTICS .....	6
DIGITAL CHARACTERISTICS .....	10
DIGITAL FILTER CHARACTERISTICS .....	10
GUARANTEED LOGIC LEVELS .....	11
RECOMMENDED OPERATING CONDITIONS .....	12
ABSOLUTE MAXIMUM RATINGS .....	12
<b>2. OVERVIEW</b> .....	<b>13</b>
<b>3. THEORY OF OPERATION</b> .....	<b>13</b>
3.1 Reset and Calibration .....	13
3.2 Performing Conversions .....	14
3.3 Clock .....	15
3.4 Voltage Reference .....	15
3.5 Analog Input .....	16
3.6 Output Coding Format .....	16
3.7 Typical Connection Diagrams .....	17
3.8 AIN & VREF Sampling Structures .....	20
3.9 Converter Performance .....	20
3.10 Digital Filter Characteristics .....	22
3.11 Serial Port .....	23
3.11.1 SSC Mode .....	23
3.11.2 SEC Mode .....	23
3.12 Power Supplies & Grounding .....	23
3.13 Using the CS5581 in Multiplexing Applications .....	24
3.14 Synchronizing Multiple Converters .....	26
<b>4. PIN DESCRIPTIONS</b> .....	<b>27</b>
<b>5. PACKAGE DIMENSIONS</b> .....	<b>30</b>
<b>6. ORDERING INFORMATION</b> .....	<b>31</b>
<b>7. ENVIRONMENTAL, MANUFACTURING, &amp; HANDLING INFORMATION</b> .....	<b>31</b>

**LIST OF FIGURES**

Figure 1. SSC Mode - Read Timing, CS remaining low . . . . . 7  
Figure 2. SSC Mode - Read Timing, CS falling after RDY falls . . . . . 8  
Figure 3. SEC Mode - Read Timing . . . . . 9  
Figure 4. Voltage Reference Circuit . . . . . 15  
Figure 5. CS5581 Configured Using  $\pm 2.5V$  Analog Supplies . . . . . 17  
Figure 6. CS5581 Configured for Unipolar Measurement Using a Single 5V Analog Supply . . . . 18  
Figure 7. CS5581 Configured for Bipolar Measurement Using a Single 5V Analog Supply . . . . 19  
Figure 8. CS5581 DNL Plot. . . . . 20  
Figure 9. CS5581 DNL Histogram . . . . . 20  
Figure 10. CS5581 Small Signal Performance . . . . . 21  
Figure 11. CS5581 Spectral Response (DC to fs/2) . . . . . 22  
Figure 12. CS5581 Spectral Response (DC to 20 kHz) . . . . . 22  
Figure 13. CS5581 Spectral Response (DC to 8fs) . . . . . 22  
Figure 14. Simple Multiplexing Scheme . . . . . 24  
Figure 15. More Complex Multiplexing Scheme . . . . . 25

**LIST OF TABLES**

Table 1. Output Coding, Two's Complement . . . . . 16  
Table 2. Output Coding, Offset Binary . . . . . 16

## 1. CHARACTERISTICS AND SPECIFICATIONS

- Min / Max characteristics and specifications are guaranteed over the specified operating conditions.
- Typical characteristics and specifications are measured at nominal supply voltages and  $T_A = 25^\circ\text{C}$ .
- VLR = 0 V. All voltages measured with respect to 0 V.

**ANALOG CHARACTERISTICS**  $T_A = -40$  to  $+85^\circ\text{C}$ ;  $V1+ = V2+ = +2.5\text{ V}$ ,  $\pm 5\%$ ;  $V1- = V2- = -2.5\text{ V}$ ,  $\pm 5\%$ ;  $V_L - V_{LR} = 3.3\text{ V}$ ,  $\pm 5\%$ ;  $V_{REF} = (V_{REF+}) - (V_{REF-}) = 4.096\text{V}$ ;  $MCLK = 16\text{ MHz}$ ;  $SMODE = V_L$ , unless otherwise stated;  $BUFEN = V1+$  unless otherwise stated. Connected per [Figure 5](#). Bipolar mode unless otherwise stated.

Parameter	Min	Typ	Max	Unit
<b>Accuracy</b>				
Linearity Error (Note 1)	-	0.0007	-	$\pm\%FS$
Differential Linearity Error (Note 2)	-	-	$\pm 0.1$	$LSB_{16}$
Positive Full-scale Error	-	1.0	-	$\%FS$
After Reset	-	1.0	-	$LSB_{16}$
After Calibration (Note 1)	-	-	-	-
Negative Full-scale Error	-	1.0	-	$\%FS$
After Reset	-	1.0	-	$LSB_{16}$
After Calibration (Note 1)	-	-	-	-
Full-scale Drift (Note 3)	-	$\pm 1$	-	$LSB_{16}$
Unipolar Offset	-	-	-	$LSB_{16}$
After Reset	-	-	-	$LSB_{16}$
After Calibration (Note 1)	-	-	-	-
Unipolar Offset Drift (Note 3)	-	$\pm 2$	-	$LSB_{16}$
Bipolar Offset	-	-	-	$LSB_{16}$
After Reset	-	-	-	$LSB_{16}$
After Calibration (Note 1)	-	-	-	-
Bipolar Offset Drift (Note 3)	-	$\pm 1$	-	$LSB_{16}$
Noise	-	TBD	-	$\mu V_{rms}$
<b>Dynamic Performance</b>				
Peak Harmonic or Spurious Noise	-	TBD	-	dB
1 kHz, -0.5 dB Input	-	TBD	-	dB
12 kHz, -0.5 dB Input	-	TBD	-	dB
Total Harmonic Distortion	-	TBD	-	dB
1 kHz, -0.5 dB Input	-	TBD	-	dB
Signal-to-Noise	-	81	-	dB
S/(N + D) Ratio	-	81	-	dB
-0.5 dB Input, 1 kHz	-	TBD	-	dB
-60 dB Input, 1 kHz	-	TBD	-	dB
-3 dB Input Bandwidth (Note 4)	-	168	-	kHz

1. Applies after calibration at any temperature within  $-40^\circ\text{C}$  to  $+85^\circ\text{C}$ .
2. No missing codes is guaranteed at 16 bits resolution over the specified temperature range.
3. Total drift over specified temperature range after calibration at power-up, at  $25^\circ\text{C}$ .
4. Scales with MCLK.

**ANALOG CHARACTERISTICS (CONTINUED)**  $T_A = -40$  to  $+85$  °C;  $V_{1+} = V_{2+} = +2.5$  V,  $\pm 5\%$ ;  $V_{1-} = V_{2-} = -2.5$  V,  $\pm 5\%$ ;  $V_L - V_{LR} = 3.3$  V,  $\pm 5\%$ ;  $V_{REF} = (V_{REF+}) - (V_{REF-}) = 4.096$ V;  $MCLK = 16$  MHz;  $SMODE = V_L$ , unless otherwise stated;  $BUFEN = V_{1+}$  unless otherwise stated. Connected per [Figure 5](#).

Parameter		Min	Typ	Max	Unit
<b>Analog Input</b>					
Analog Input Range	Unipolar Bipolar		0 to $+V_{REF} / 2$ $\pm V_{REF} / 2$		V V
Input Capacitance		-	10	-	pF
CVF Current (Note 5)	AIN Buffer On ( $BUFEN = V_{+}$ )	-	600	-	nA
	AIN Buffer Off ( $BUFEN = V_{-}$ )	-	130	-	$\mu$ A
	ACOM	-	130	-	$\mu$ A
<b>Voltage Reference Input</b>					
Voltage Reference Input Range ( $V_{REF+}$ ) – ( $V_{REF-}$ )	(Note 6)	2.4	4.096	4.2	V
Input Capacitance		-	10	-	pF
CVF Current	$V_{REF+}$ Buffer On ( $BUFEN = V_{+}$ )	-	3	-	$\mu$ A
	$V_{REF+}$ Buffer Off ( $BUFEN = V_{-}$ )	-	1	-	mA
	$V_{REF-}$	-	1	-	mA
<b>Power Supplies</b>					
DC Power Supply Currents	$I_{V1}$	-	-	18	mA
	$I_{V2}$	-	-	1.8	mA
	$I_{V_L}$	-	-	0.5	mA
Power Consumption	Normal Operation Buffers On	-	85	105	mW
	Normal Operation Buffers Off	-	60	90	mW
Power Supply Rejection	(Note 7) $V_{1+}$ , $V_{2+}$ Supplies	90	110	-	dB
	$V_{1-}$ , $V_{2-}$ Supplies	90	110	-	dB

5. Measured using an input signal of 1 V DC.

6. For optimum performance,  $V_{REF+}$  should always be less than  $(V_{+}) - 0.2$  volts to prevent saturation of the  $V_{REF+}$  input buffer.

7. Tested with 100 mVP-P on any supply up to 1 kHz.  $V_{1+}$  and  $V_{2+}$  supplies at the same voltage potential,  $V_{1-}$  and  $V_{2-}$  supplies at the same voltage potential.

## SWITCHING CHARACTERISTICS

$T_A = -40$  to  $+85$  °C;  $V_{1+} = V_{2+} = +2.5$  V,  $\pm 5\%$ ;  $V_{1-} = V_{2-} = -2.5$  V,  $\pm 5\%$ ;

$V_L - V_{LR} = 3.3$  V,  $\pm 5\%$ ,  $2.5$  V,  $\pm 5\%$ , or  $1.8$  V,  $\pm 5\%$

Input levels: Logic 0 = 0V; Logic 1 =  $V_{D+}$ ; CL = 15 pF.

Parameter		Symbol	Min	Typ	Max	Unit
Master Clock Frequency	Internal Oscillator	XIN	12	14	16	MHz
	External Clock	$f_{clk}$	0.5	16	16.2	MHz
Master Clock Duty Cycle			40	-	60	%
<b>Reset</b>						
RST Low Time	(Note 8)	$t_{res}$	1	-	-	$\mu$ s
RST rising to RDY falling	Internal Oscillator	$t_{wup}$	-	120	-	$\mu$ s
	External Clock		-	1536	-	MCLKs
<b>Calibration</b>						
CAL pulse width	(Note 9, 10)	$t_{pw}$	4	-	-	MCLKs
CAL high setup time to RST rising	(Note 9, 10)	$t_{ccw}$	0	-	-	ns
Calibration Time RST rising (CAL high) to RDY falling		$t_{scl}$	-	85218	-	MCLKs
Calibration Time CAL rising (RST high) to RDY falling		$t_{cal}$	-	85218	-	MCLKs
<b>Conversion</b>						
CONV Pulse Width		$t_{cpw}$	4	-	-	MCLKs
BP/UP setup to CONV falling	(Note 11)	$t_{scn}$	0	-	-	ns
CONV low to start of conversion		$t_{scn}$	-	-	2	MCLKs
Perform Single Conversion (CONV high before RDY falling)		$t_{bus}$	20	-	-	MCLKs
Conversion Time Start of Conversion to RDY falling	(Note 12)	$t_{buh}$	-	-	84	MCLKs

8. Reset must not be released until the power supplies and the voltage reference are within specification.
9. CAL must remain high until RDY falls at the end of the calibration time.
10. CAL can be controlled by the same signal used for RST. If CAL goes high simultaneously with RST, a calibration will be performed. CAL must remain high until RDY falls.
11. BP/UP can be changed coincident CONV falling. BP/UP must remain stable until RDY falls.
12. If CONV is held low continuously, conversions occur every 80 MCLK cycles.  
If RDY is tied to CONV, conversions will occur every 82 MCLKs.  
If CONV is operated asynchronously to MCLK, a conversion may take up to 84 MCLKs.  
RDY falls at the end of conversion.

### SWITCHING CHARACTERISTICS (CONTINUED)

$T_A = -40$  to  $+85$  °C;  $V_{1+} = V_{2+} = +2.5$  V,  $\pm 5\%$ ;  $V_{1-} = V_{2-} = -2.5$  V,  $\pm 5\%$ ;

$V_L - V_{LR} = 3.3$  V,  $\pm 5\%$ ,  $2.5$  V,  $\pm 5\%$ , or  $1.8$  V,  $\pm 5\%$

Input levels: Logic 0 = 0V; Logic 1 =  $V_{D+}$ ;  $C_L = 15$  pF.

Parameter	Symbol	Min	Typ	Max	Unit
<b>Serial Port Timing in SSC Mode (SMODE = VL)</b>					
$\overline{RDY}$ falling to MSB stable	$t_1$	-	-2	-	MCLKs
Data hold time after SCLK rising	$t_2$	-	10	-	ns
Serial Clock (Out) (Note 13, 14)	Pulse Width (low)	50	-	-	ns
	Pulse Width (high)	50	-	-	ns
$\overline{RDY}$ rising after last SCLK rising	$t_5$	-	8	-	MCLKs

13. SDO and SCLK will be high impedance when  $\overline{CS}$  is high. In some systems it may require a pull-down resistor.

14. SCLK = MCLK/2.

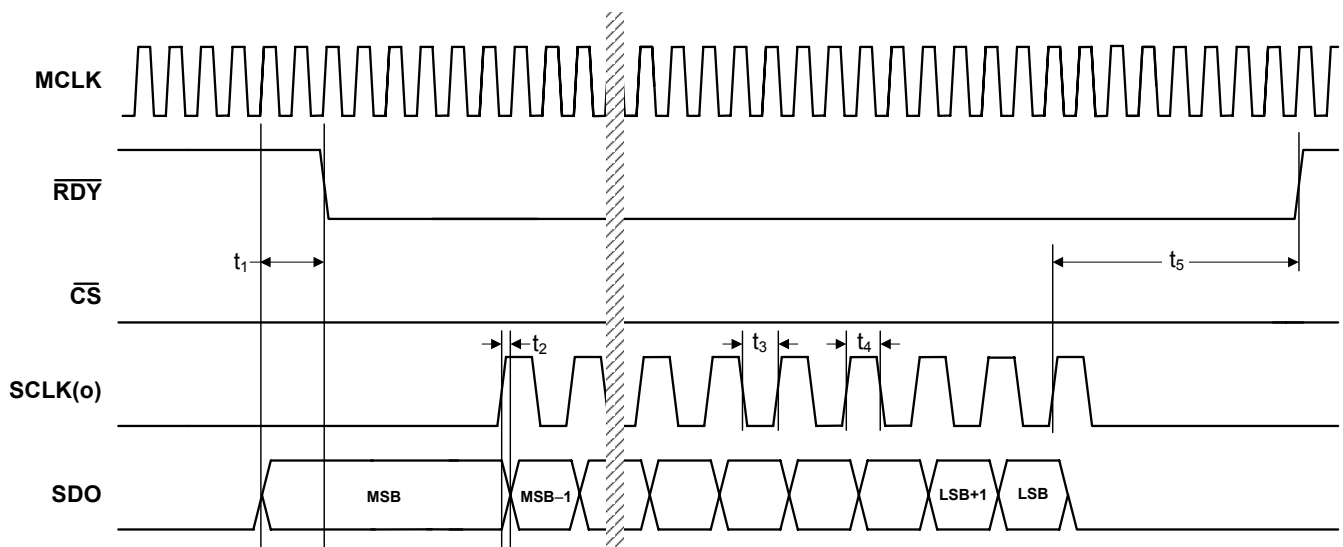

Figure 1. SSC Mode - Read Timing,  $\overline{CS}$  remaining low (Not to Scale)

### SWITCHING CHARACTERISTICS (CONTINUED)

$T_A = -40$  to  $+85$  °C;  $V_{1+} = V_{2+} = +2.5$  V,  $\pm 5\%$ ;  $V_{1-} = V_{2-} = -2.5$  V,  $\pm 5\%$ ;

$V_L - V_{LR} = 3.3$  V,  $\pm 5\%$ ,  $2.5$  V,  $\pm 5\%$ , or  $1.8$  V,  $\pm 5\%$

Input levels: Logic 0 = 0V; Logic 1 =  $V_{D+}$ ;  $C_L = 15$  pF.

Parameter	Symbol	Min	Typ	Max	Unit
<b>Serial Port Timing in SSC Mode (SMODE = VL)</b>					
Data hold time after SCLK rising	$t_7$	-	10	-	ns
Serial Clock (Out) (Note 15, 16)	Pulse Width (low)	50	-	-	ns
	Pulse Width (high)	50	-	-	ns
$\overline{RDY}$ rising after last SCLK rising	$t_{10}$	-	8	-	MCLKs
$\overline{CS}$ falling to MSB stable	$t_{11}$	-	10	-	ns
First SCLK rising after $\overline{CS}$ falling	$t_{12}$	-	8	-	MCLKs
$\overline{CS}$ hold time (low) after SCLK rising	$t_{13}$	10	-	-	ns
SCLK, SDO tristate after $\overline{CS}$ rising	$t_{14}$	-	5	-	ns

15. SDO and SCLK will be high impedance when  $\overline{CS}$  is high. In some systems it may require a pull-down resistor.

16.  $SCLK = MCLK/2$ .

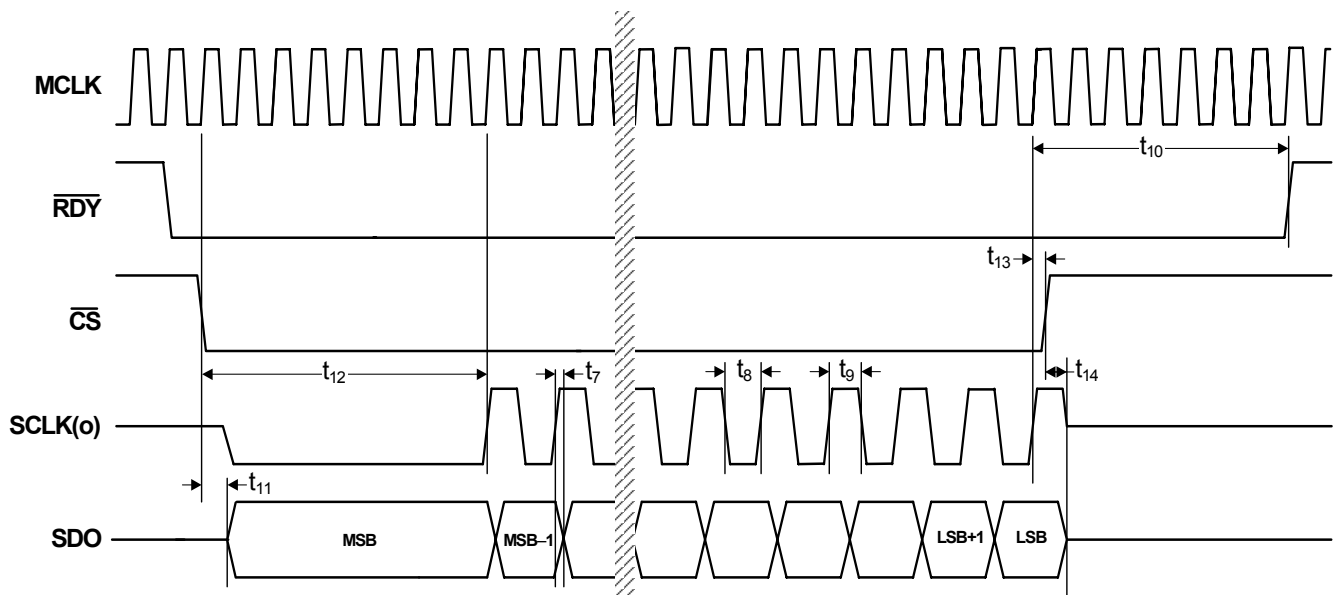

Figure 2. SSC Mode - Read Timing,  $\overline{CS}$  falling after  $\overline{RDY}$  falls (Not to Scale)



**SWITCHING CHARACTERISTICS (CONTINUED)**

$T_A = -40$  to  $+85$  °C;  $V_{1+} = V_{2+} = +2.5$  V,  $\pm 5\%$ ;  $V_{1-} = V_{2-} = -2.5$  V,  $\pm 5\%$ ;

$V_L - V_{LR} = 3.3$  V,  $\pm 5\%$ , 2.5 V,  $\pm 5\%$ , or 1.8 V,  $\pm 5\%$

Input levels: Logic 0 = 0V; Logic 1 =  $V_{D+}$ ;  $C_L = 15$  pF.

Parameter	Symbol	Min	Typ	Max	Unit
<b>Serial Port Timing in SEC Mode (SMODE = VLR)</b>					
SCLK(in) Pulse Width (High)	-	30	-	-	ns
SCLK(in) Pulse Width (Low)	-	30	-	-	ns
$\overline{CS}$ hold time (high) after $\overline{RDY}$ falling	$t_{15}$	10	-	-	ns
$\overline{CS}$ hold time (high) after SCLK rising	$t_{16}$	10	-	-	ns
$\overline{CS}$ low to SDO out of Hi-Z (Note 17)	$t_{17}$	-	10	-	ns
Data hold time after SCLK rising	$t_{18}$	-	10	-	ns
Data setup time before SCLK rising	$t_{19}$	10	-	-	ns
$\overline{CS}$ hold time (low) after SCLK rising	$t_{20}$	10	-	-	ns
$\overline{RDY}$ rising after SCLK falling	$t_{21}$	-	10	-	ns

17. SDO will be high impedance when  $\overline{CS}$  is high. In some systems it may require a pull-down resistor.

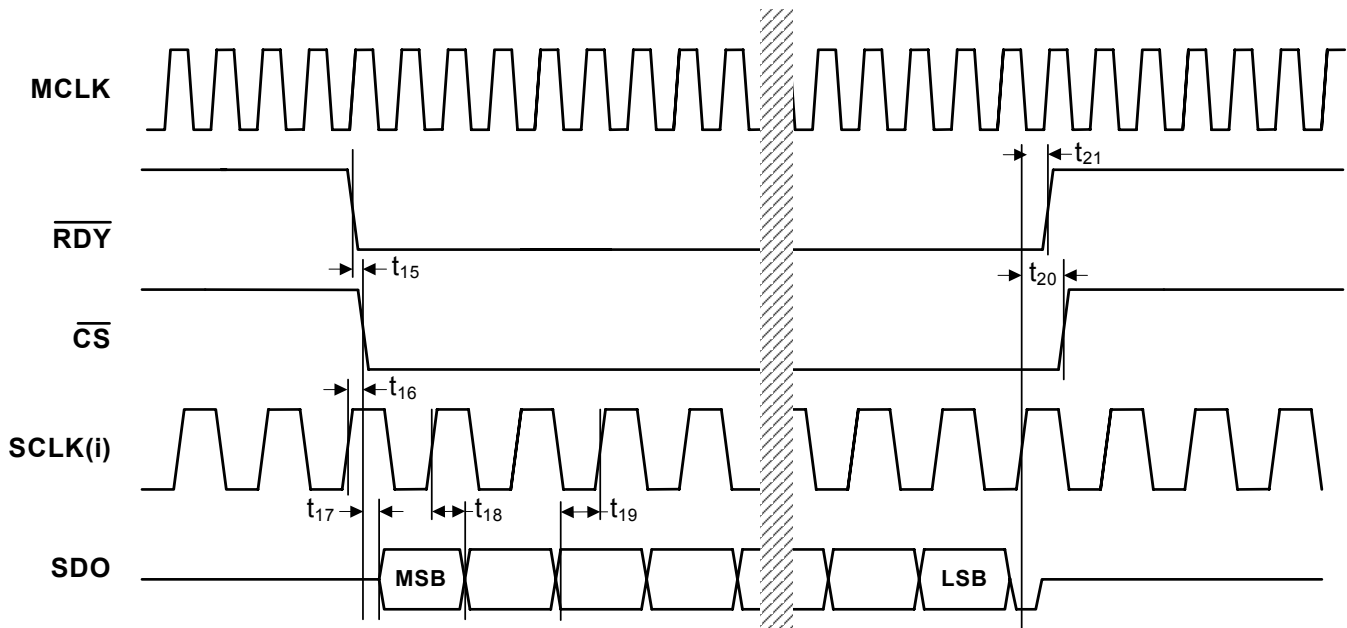

Figure 3. SEC Mode - Read Timing (Not to Scale)

## DIGITAL CHARACTERISTICS

$T_A$  = TMIN to TMAX; VL = 3.3V, ±5% or VL = 2.5V, ±5% or 1.8V, ±5%; VLR = 0V

Parameter	Symbol	Min	Typ	Max	Unit
Calibration Memory Retention (Note 18) Power Supply Voltage [V1+ = V2+] – [V1- = V2-]	$V_{MR}$	4.0	-	-	V
Input Leakage Current	$I_{in}$	-	-	2	μA
Digital Input Pin Capacitance	$C_{in}$	-	3	-	pF
Digital Output Pin Capacitance	$C_{out}$	-	3	-	pF

18. V1- and V2- can be any value from 0 to +5V for memory retention. Neither V1- nor V2- should be allowed to go positive. AIN1, AIN2, or VREF must not be greater than V1+ or V2+. This parameter is guaranteed by characterization.

## DIGITAL FILTER CHARACTERISTICS

$T_A$  = TMIN to TMAX; VL = 3.3V, ±5% or VL = 2.5V, ±5% or 1.8V, ±5%; VLR = 0V

Parameter	Symbol	Min	Typ	Max	Unit
Group Delay	-	-	80	-	MCLKs

## GUARANTEED LOGIC LEVELS

$T_A = -40$  to  $+85$  °C;  $V_{1+} = V_{2+} = +2.5$  V,  $\pm 5\%$ ;  $V_{1-} = V_{2-} = -2.5$  V,  $\pm 5\%$ ;

VL - VLR = 3.3 V,  $\pm 5\%$ , 2.5 V,  $\pm 5\%$ , or 1.8 V,  $\pm 5\%$

Input levels: Logic 0 = 0V; Logic 1 = VL; CL = 15 pF.

Parameter	Sym	VL	Guaranteed Limits			Unit	Conditions
			Min	Typ	Max		
<b>Logic Inputs</b>							
Minimum High-level Input Voltage:	$V_{IH}$	3.3	1.9			V	
		2.5	1.6				
		1.8	1.2				
Maximum Low-level Input Voltage:	$V_{IL}$	3.3			1.1	V	
		2.5			0.95		
		1.8			0.6		
<b>Logic Outputs</b>							
Minimum High-level Output Voltage:	$V_{OH}$	3.3	2.9			V	$I_{OH} = -2$ mA
		2.5	2.1				
		1.8	1.65				
Maximum Low-level Output Voltage:	$V_{OL}$	3.3			0.36	V	$I_{OH} = -2$ mA
		2.5			0.36		
		1.8			0.44		

## RECOMMENDED OPERATING CONDITIONS

(VLR = 0V, see Note 19)

Parameter	Symbol	Min	Typ	Max	Unit
<b>Single Analog Supply</b>					
DC Power Supplies: (Note 19)					
V1+	V1+	4.75	5.0	5.25	V
V2+	V2-	4.75	5.0	5.25	V
V1-	V1+	-	0	-	V
V2-	V2-	-	0	-	V
<b>Dual Analog Supplies</b>					
DC Power Supplies: (Note 19)					
V1+	V1+	+2.375	+2.5	+2.625	V
V2+	V2-	+2.375	+2.5	+2.625	V
V1-	V1+	-2.375	-2.5	-2.625	V
V2-	V2-	-2.375	-2.5	-2.625	V
Analog Reference Voltage (Note 20) [VREF+] – [VREF-]	VREF	2.4	4.096	4.2	V

19. The logic supply can be any value VL – VLR = +1.71 to +3.465 volts as long as VLR ≥ V2- and VL ≤ 3.465 V.

20. The differential voltage reference magnitude is constrained by the V1+ or V1- supply magnitude.

## ABSOLUTE MAXIMUM RATINGS

(VLR = 0V)

Parameter	Symbol	Min	Typ	Max	Unit
DC Power Supplies:					
[V1+] – [V1-] (Note 21)	-	0	-	5.5	V
VL + [  V1-  ] (Note 22)	-	0	-	6.1	V
Input Current, Any Pin Except Supplies (Note 23)	I <sub>IN</sub>	-	-	±10	mA
Analog Input Voltage (AIN and VREF pins)	V <sub>INA</sub>	(V1-) – 0.3	-	(V1+) + 0.3	V
Digital Input Voltage	V <sub>IND</sub>	VLR – 0.3	-	VL + 0.3	V
Storage Temperature	T <sub>stg</sub>	-65	-	150	°C

Notes: 21. V1+ = V2+; V1- = V2-

22. V1- = V2-

23. Transient currents of up to 100 mA will not cause SCR latch-up.

### WARNING:

Recommended Operating Conditions indicate limits to which functional operation of the device is guaranteed. Absolute Maximum Ratings indicate limits beyond which permanent damage to the device may occur. The Absolute Maximum Ratings are stress ratings only and the device should not be operated at these limits. Operation at conditions beyond the Recommended Operating Conditions may affect device reliability; functional operation beyond Recommended Operating Conditions is not implied. Performance specifications are guaranteed under the conditions specified for each table in the Characteristics and Specifications section.

## 2. OVERVIEW

The CS5581 is a 16-bit analog-to-digital converter capable of 200 kSps conversion rate. The analog input accepts a single-ended input with a magnitude of  $\pm V_{REF} / 2$  volts. The device is capable of switching multiple input channels at a high rate with no loss in throughput. The ADC uses a low-latency digital filter architecture. The filter is designed for fast settling and settles to full accuracy in one conversion.

The converter is a serial output device. The serial port can be configured to function as either a master or a slave.

The CS5581 provides self-calibration circuitry to achieve low offset and gain errors.

The converter can operate from an analog supply of 5V or from  $\pm 2.5V$ . The digital interface supports standard logic operating from 1.8, 2.5, or 3.3 V.

The CS5581 may convert at rates up to 200 kSps when operating from a 16 MHz input clock.

## 3. THEORY OF OPERATION

The CS5581 converter provides high-performance measurement of DC or AC signals. The converter includes on-chip calibration circuitry to minimize offset and gain errors. The converter can be used to perform single conversions or continuous conversions upon command. Each conversion is independent of previous conversions and settles to full specified accuracy, even with a full-scale input voltage step. This is due to the converter architecture which uses a combination of a high-speed delta-sigma modulator and a low-latency filter architecture.

Once power is established to the converter, a reset must be performed. A reset initializes the internal converter logic and sets the offset register to zero and the gain register to a decimal value of 1.0. If the CAL pin is low when  $\overline{RST}$  returns high, no calibration will be performed. If CAL is high when  $\overline{RST}$  transitions from low to high, the converter's offset & gain slope will be calibrated.

If  $\overline{CONV}$  is held low then the converter will convert continuously with  $\overline{RDY}$  falling every 80 MCLKs. This is equivalent to 200 kSps if MCLK = 16.0 MHz. If  $\overline{CONV}$  is tied to  $\overline{RDY}$ , a conversion will occur every 82 MCLKs. If  $\overline{CONV}$  is operated asynchronously to MCLK, it may take up to 84 MCLKs from  $\overline{CONV}$  falling to  $\overline{RDY}$  falling.

Multiple converters can operate synchronously if they are driven by the same MCLK source and  $\overline{CONV}$  to each converter falls on the same MCLK falling edge. Alternately,  $\overline{CONV}$  can be held low and all devices are reset with  $\overline{RST}$  rising on the same falling edge of MCLK.

The output coding of the conversion word is a function of the  $\overline{BP/UP}$  pin.

### 3.1 Reset and Calibration

After the power supplies and the voltage reference are stable, the converter must be reset. The reset function initializes the internal logic in the converter, but does not initiate calibration. After reset has been performed, the converter can be used uncalibrated, or calibration can be performed. Calibration minimizes offset and gain errors inside the converter. If the device is used without calibration, conversions will include the offset and gain errors of the uncalibrated converter, but the converter will maintain its differential and integral linearity. Calibration of offset and gain can be performed upon command.

Calibration can be initiated in either of two ways. If CAL is high when  $\overline{RST}$  transitions from low to high a calibration cycle will be performed immediately after a reset is performed. When calibration is performed, the offset and full-scale points of the converter are calibrated. A calibration cycle takes 85218 MCLK cycles.

The  $\overline{\text{RDY}}$  signal falls upon completion of reset and calibration sequence. If  $\overline{\text{CAL}}$  remains low when  $\overline{\text{RST}}$  transitions from low to high, no calibration will be performed. Calibrations can be initiated any time the converter is idle by taking the  $\overline{\text{CAL}}$  input high.  $\overline{\text{RDY}}$  will fall at the end of the calibration cycle. The  $\overline{\text{CAL}}$  pin should be returned low when not being used.

A calibration cycle calibrates the offset and full-scale points of the converter transfer function. When the offset portion of the calibration is performed, the  $\overline{\text{AIN}}$  and  $\overline{\text{ACOM}}$  pins are disconnected from the input and shorted internally. The offset of the converter is then measured and a correction factor is stored in a register. Then the voltage reference is internally connected to act as the input signal to the converter and a gain calibration is performed. The gain correction results are also placed in a register. The contents of the offset and gain registers are used to map the conversion data prior to its output from the converter.

### 3.2 Performing Conversions

The CS5581 converts at 200 kSps when synchronously operated ( $\overline{\text{CONV}} = \text{VLR}$ ) from a 16.0 MHz master clock. Conversion is initiated by taking  $\overline{\text{CONV}}$  low. A conversion lasts 80 master clock cycles, but if  $\overline{\text{CONV}}$  is asynchronous to  $\overline{\text{MCLK}}$  there may be an uncertainty of 0-4  $\overline{\text{MCLK}}$  cycles after  $\overline{\text{CONV}}$  falls to when a conversion actually begins. This may extend the throughput to 84  $\overline{\text{MCLK}}$ s per conversion.

When the conversion is completed, the output word is placed into the serial port and  $\overline{\text{RDY}}$  goes low. To convert continuously,  $\overline{\text{CONV}}$  should be held low. In continuous conversion mode with  $\overline{\text{CONV}}$  held low, a conversion is performed in 80  $\overline{\text{MCLK}}$  cycles. Alternately  $\overline{\text{RDY}}$  can be tied to  $\overline{\text{CONV}}$  and a conversion will occur every 82  $\overline{\text{MCLK}}$  cycles.

To perform only one conversion,  $\overline{\text{CONV}}$  should return high at least 20 master clock cycles before  $\overline{\text{RDY}}$  falls.

Once a conversion is completed and  $\overline{\text{RDY}}$  falls,  $\overline{\text{RDY}}$  will return high when all the bits of the data word are emptied from the serial port or if the conversion data is not read and  $\overline{\text{CS}}$  is held low,  $\overline{\text{RDY}}$  will go high two  $\overline{\text{MCLK}}$  cycles before the end of conversion.  $\overline{\text{RDY}}$  will fall at the end of the next conversion when new data is put into the port register.

See [Serial Port](#) on page 23 for information about reading conversion data.

Conversion performance can be affected by several factors. These include the choice of clock source for the chip, the timing of  $\overline{\text{CONV}}$ , and the choice of the serial port mode.

The converter can be operated from an internal oscillator. This clock source has greater jitter than an external crystal-based clock. Jitter may not be an issue when measuring DC signals, or very-low-frequency AC signals, but can become an issue for higher frequency AC signals. For maximum performance when digitizing AC signals, a low-jitter  $\overline{\text{MCLK}}$  should be used.

To maximize performance, the  $\overline{\text{CONV}}$  pin should be held low in the continuous conversion state to perform multiple conversions, or  $\overline{\text{CONV}}$  should occur synchronous to  $\overline{\text{MCLK}}$ , falling when  $\overline{\text{MCLK}}$  falls.

When performing conversions on an AC signal,  $\overline{\text{CONV}}$  should be held low in the continuous conversion state to perform multiple conversions, or  $\overline{\text{CONV}}$  should occur synchronous to  $\overline{\text{MCLK}}$ , falling when  $\overline{\text{MCLK}}$  falls.

If the converter is operated at maximum throughput, the SSC serial port mode is less likely to cause interference to measurements as the  $\overline{\text{SCLK}}$  output is synchronized to the  $\overline{\text{MCLK}}$ . Alternately, any interference due to serial port clocking can also be minimized if data is read in the SEC serial port mode when a conversion is not in progress.

### 3.3 Clock

The CS5581 can be operated from its internal oscillator or from an external master clock. The state of MCLK determines which clock source will be used. If MCLK is tied low, the internal oscillator will start and be used as the clock source for the converter. If an external CMOS-compatible clock is input into MCLK, the converter will power down the internal oscillator and use the external clock. If the MCLK pin is held high, the internal oscillator will be held in the stopped state. The MCLK input can be held high to delete clock cycles to aid in operating multiple converters in different phase relationships.

The internal oscillator can be used if the signals to be measured are essentially DC. The internal oscillator exhibits jitter at about 500 picoseconds rms. If the CS5581 is used to digitize AC signals, an external low-jitter clock source should be used.

If the internal oscillator is used as the clock for the CS5581, the maximum conversion rate will be dictated by the oscillator frequency.

### 3.4 Voltage Reference

The voltage reference for the CS5581 can range from 2.4 volt to 4.2 volts. A 4.096 volt reference is required to achieve the specified signal-to-noise performance. [Figure 5](#) and [Figure 6](#) illustrate the connection of the voltage reference with either a single +5 V analog supply or with  $\pm 2.5$  V.

For optimum performance, the voltage reference device should be one that provides a capacitor connection to provide a means of noise filtering, or the output should include some type of bandwidth-limiting filter.

Some 4.096 volt reference devices need only 5 volts total supply for operation and can be connected as shown in [Figure 5](#) or [Figure 6](#). The reference should have a local bypass capacitor and an appropriate output capacitor.

Some older 4.096 voltage reference designs require more headroom and must operate from an input voltage of 5.5 to 6.5 volts. If this type of voltage reference is used ensure that when power is applied to the system, the voltage reference rise time is slower than the rise time of the V1+ and V1- power supply voltage to the converter. An example circuit to slow the output startup time of the reference is illustrated in [Figure 4](#).

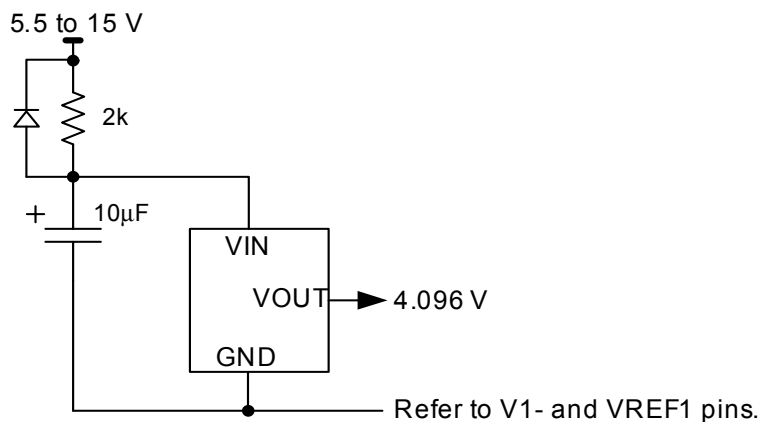

Figure 4. Voltage Reference Circuit

### 3.5 Analog Input

The analog input of the converter is single-ended with an full-scale input of  $\pm 2.048$  volts. This is illustrated in [Figure 5](#) and [Figure 6](#). These diagrams also illustrate a differential buffer amplifier configuration for driving the CS5581.

The capacitors at the outputs of the amplifiers provide a charge reservoir for the dynamic current from the A/D inputs while the resistors isolate the dynamic current from the amplifier. The amplifiers can be powered from higher supplies than those used by the A/D but precautions should be taken to ensure that the op amp output voltage remains within the power supply limits of the A/D, especially under start-up conditions.

### 3.6 Output Coding Format

The reference voltage directly defines the input voltage range in both the unipolar and bipolar configurations. In the unipolar configuration (BP/UP low), the first code transition occurs 0.5 LSB above zero, and the final code transition occurs 1.5 LSBs below VREF. In the bipolar configuration (BP/UP high), the first code transition occurs 0.5 LSB above -VREF and the last transition occurs 1.5 LSBs below +VREF. See [Table 1](#) for the output coding of the converter.

**Table 1. Output Coding, Two's Complement**

Bipolar Input Voltage	Two's Complement
$>(VREF-1.5 \text{ LSB})$	7F FF
$VREF-1.5 \text{ LSB}$	7F FF 7F FE
$-0.5 \text{ LSB}$	00 00 FF FF
$-VREF+0.5 \text{ LSB}$	80 01 80 00
$<(-VREF+0.5 \text{ LSB})$	80 00

NOTE:  $VREF = [(VREF+) - (VREF-)] / 2$

**Table 2. Output Coding, Offset Binary**

Unipolar Input Voltage	Offset Binary
$>(VREF-1.5 \text{ LSB})$	FF FF
$VREF-1.5 \text{ LSB}$	FF FF FF FE
$(VREF/2)-0.5 \text{ LSB}$	80 00 7F FF
$+0.5 \text{ LSB}$	00 01 00 00
$<(+0.5 \text{ LSB})$	00 00

NOTE:  $VREF = [(VREF+) - (VREF-)] / 2$



### 3.7 Typical Connection Diagrams

The following figure depicts the CS5581 powered from bipolar analog supplies, +2.5 V and - 2.5 V.

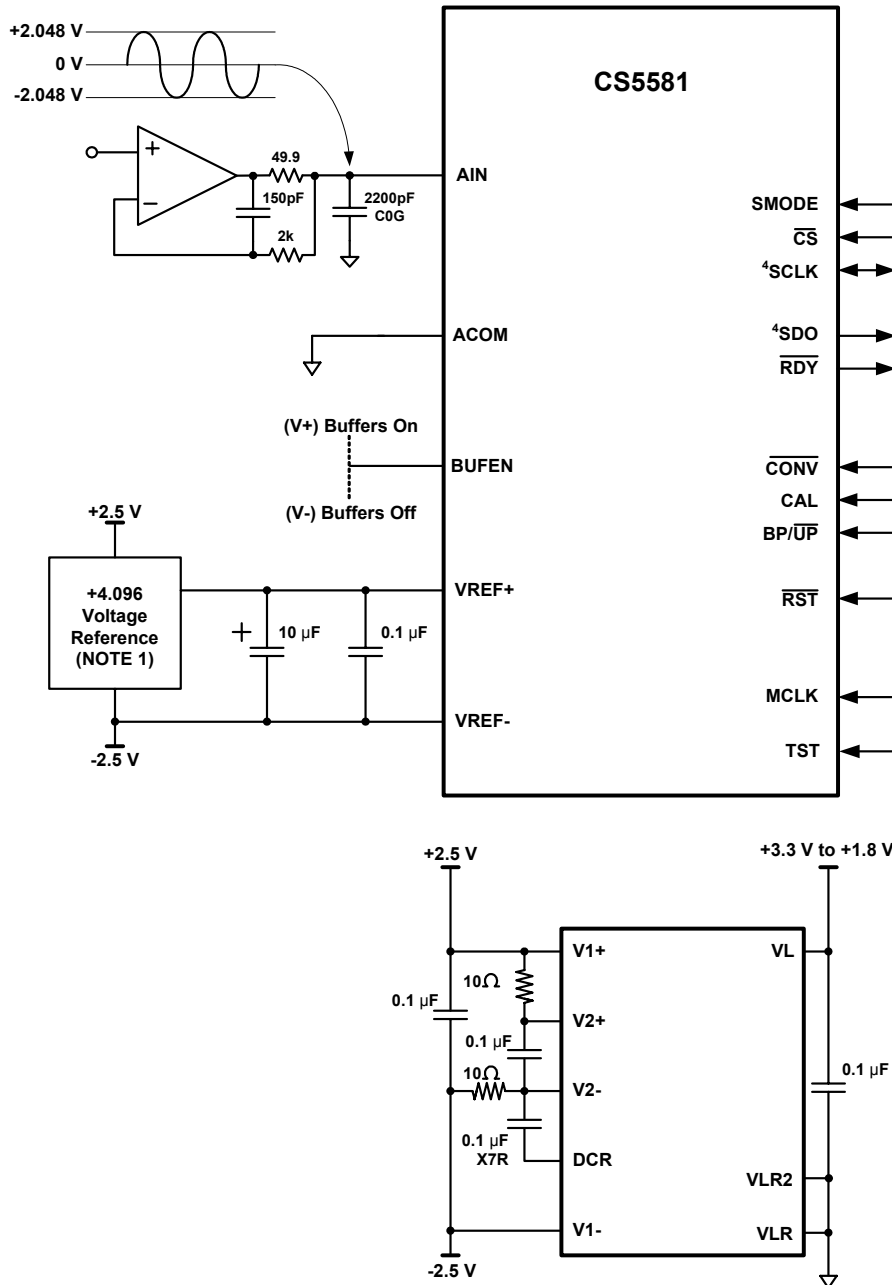

NOTES

1. See Section 3.4 Voltage Reference for information on required voltage reference performance criteria.
2. Locate capacitors so as to minimize loop length.
3. The  $\pm 2.5$  V supplies should also be bypassed to ground at the converter.
4. VLR and the power supply ground for the  $\pm 2.5$  V should be connected to the same ground plane under the chip.
5. SCLK and SDO may require pull-down resistors in some applications.

Figure 5. CS5581 Configured Using  $\pm 2.5$ V Analog Supplies

The following figure depicts the CS5581 part powered from a single 5V analog supply and configured for unipolar measurement.

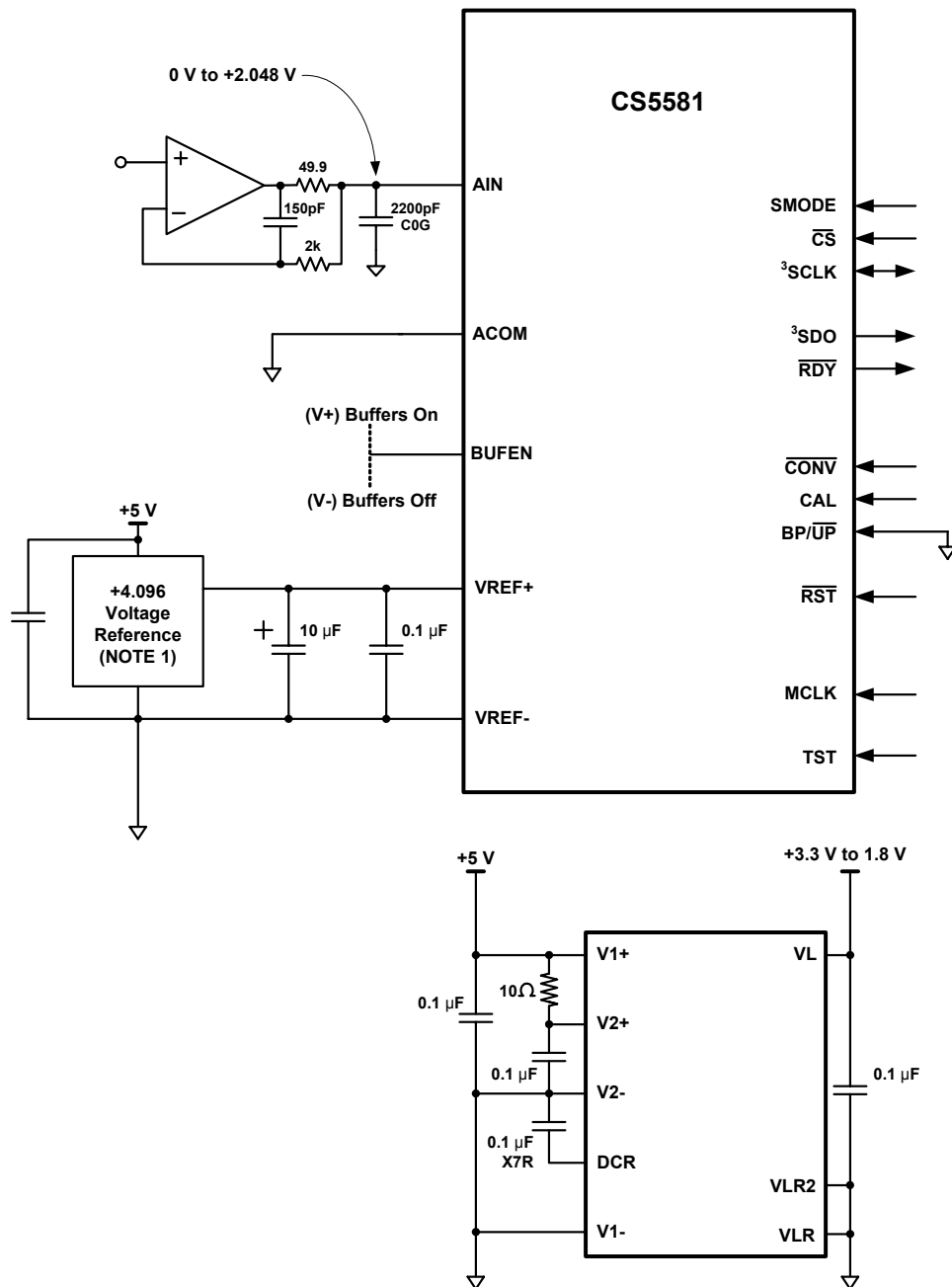

NOTES

1. See Section 3.4 Voltage Reference for information on required voltage reference performance criteria.
2. Locate capacitors so as to minimize loop length.
3. V1-, V2-, and VLR should be connected to the same ground plane under the chip.
4. SCLK and SDO may require pull-down resistors in some applications.

Figure 6. CS5581 Configured for Unipolar Measurement Using a Single 5V Analog Supply

The following figure depicts the CS5581 part powered from a single 5V analog supply and configured for bipolar measurement, referenced to a common mode voltage of 2.5 V.

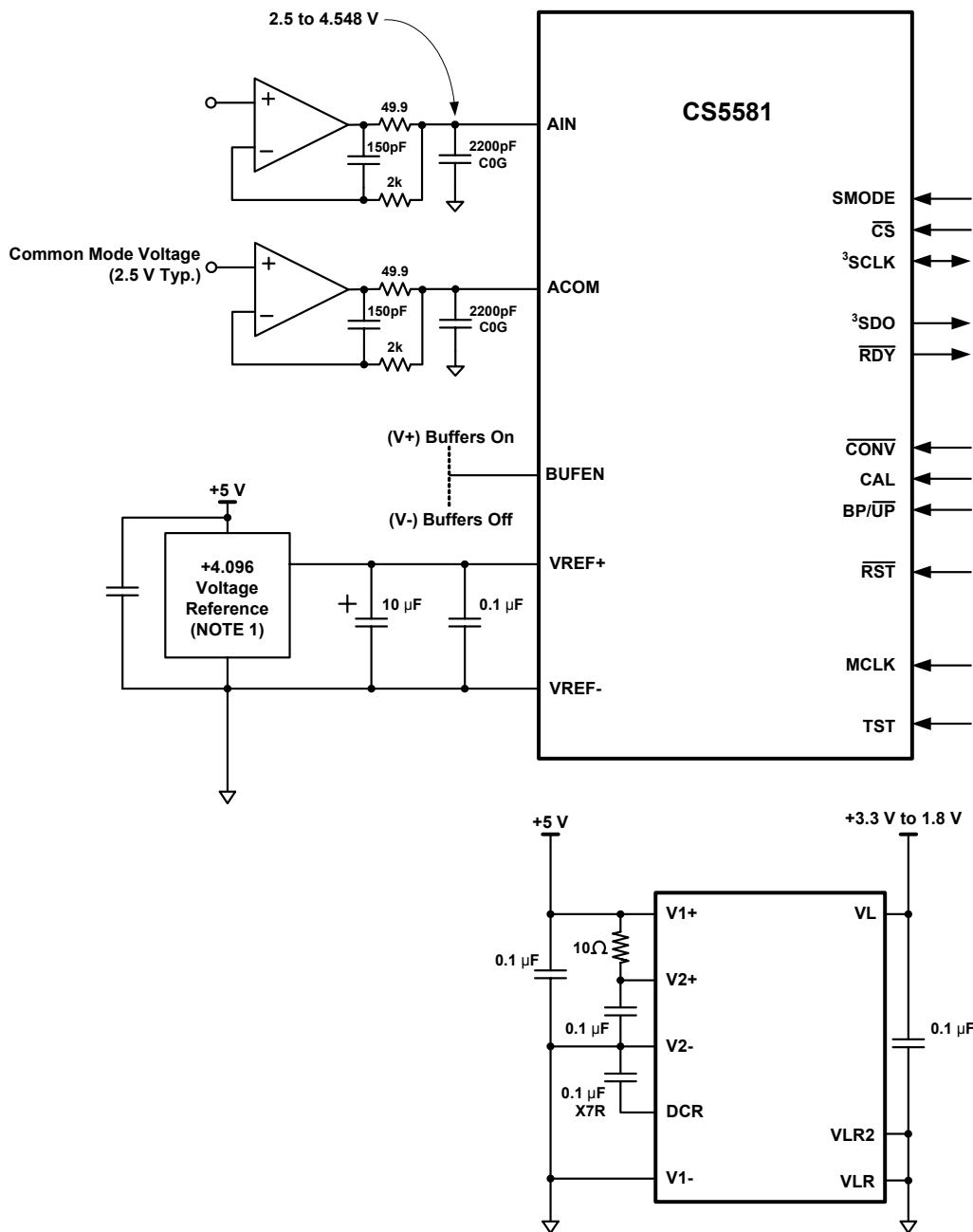

NOTES

1. See Section 3.4 Voltage Reference for information on required voltage reference performance criteria.
2. Locate capacitors so as to minimize loop length.
3. V1-, V2-, and VLR should be connected to the same ground plane under the chip.
4. SCLK and SDO may require pull-down resistors in some applications.

Figure 7. CS5581 Configured for Bipolar Measurement Using a Single 5V Analog Supply

### 3.8 AIN & VREF Sampling Structures

The CS5581 uses on-chip buffers on the AIN, ACOM, and the VREF+ inputs. Buffers provide much higher input impedance and therefore reduce the amount of drive current required from an external source. This helps minimize errors.

The Buffer Enable (BUFEN) pin determines if the on-chip buffers are used or not. If the BUFEN pin is connected to the V1+ supply the buffers will be enabled. If the BUFEN pin is connected to the V1- pin the buffers are off. The converter will consume about 30 mW less power when the buffers are off, but the input impedances of AIN, ACOM and VREF+ will be significantly less than with the buffers enabled.

### 3.9 Converter Performance

The CS5581 achieves excellent differential nonlinearity (DNL) as shown in Figures 8 and 9. Figure 8 illustrates the code widths on the typical scale of  $\pm 1$  LSB and on a zoomed scale of  $\pm 0.1$  LSB. The DNL error histogram in Figure 9 indicates that more than half the codes are accurate to better than  $\pm 0.01$  LSB.

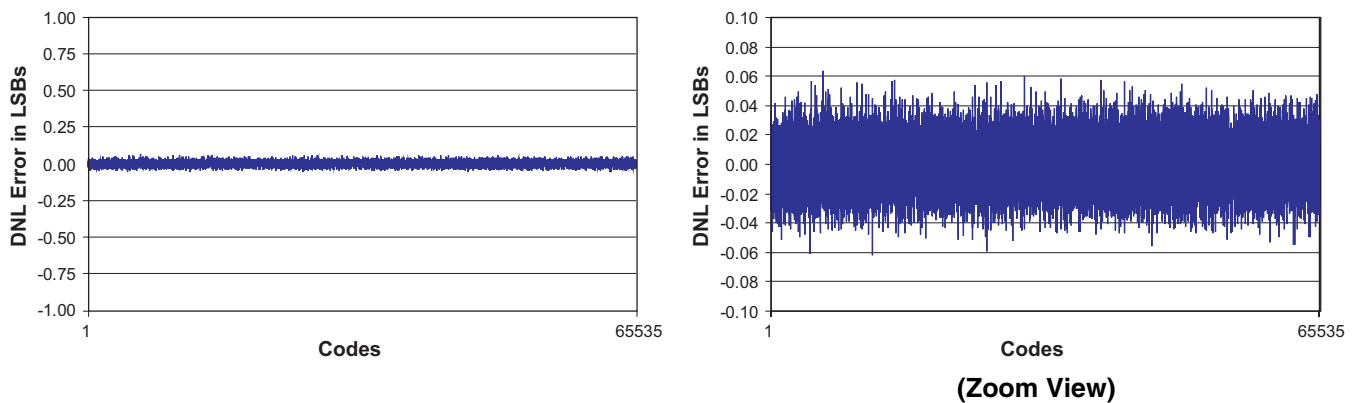

Figure 8. CS5581 DNL Plot

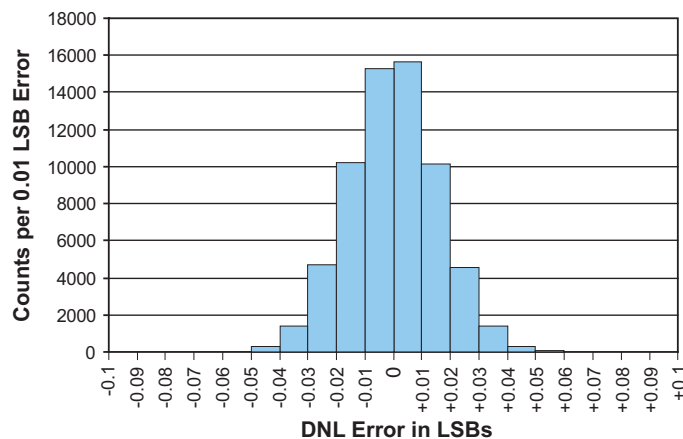
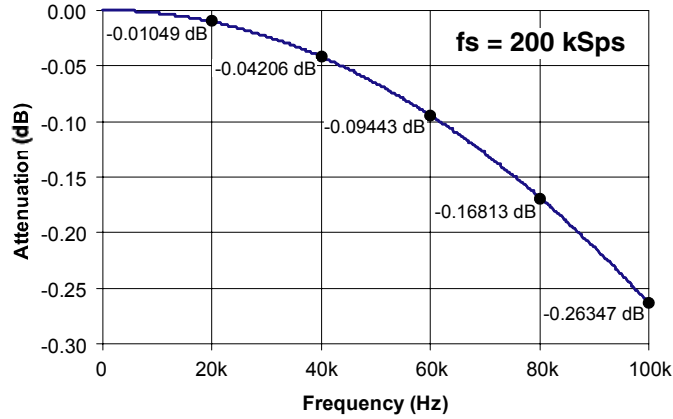

Figure 9. CS5581 DNL Histogram

Figure 10. CS5581 Small Signal Performance

### 3.10 Digital Filter Characteristics

The digital filter is designed for fast settling, therefore it exhibits very little in-band attenuation. The filter attenuation is 1.040 dB at 50 kHz when sampling at 200 kSps.



**Figure 11. CS5581 Spectral Response (DC to fs/2)**

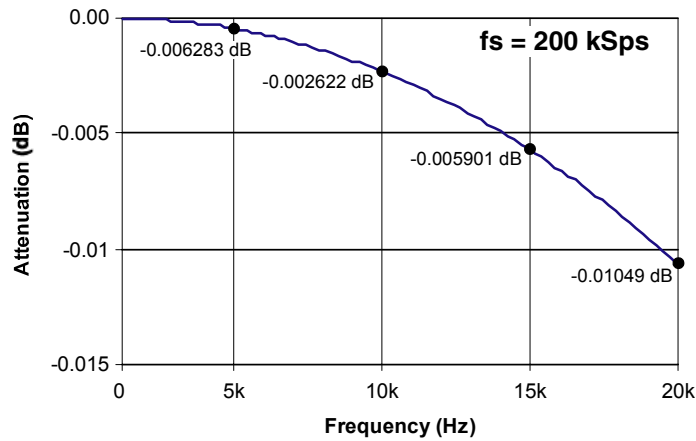

**Figure 12. CS5581 Spectral Response (DC to 20 kHz)**

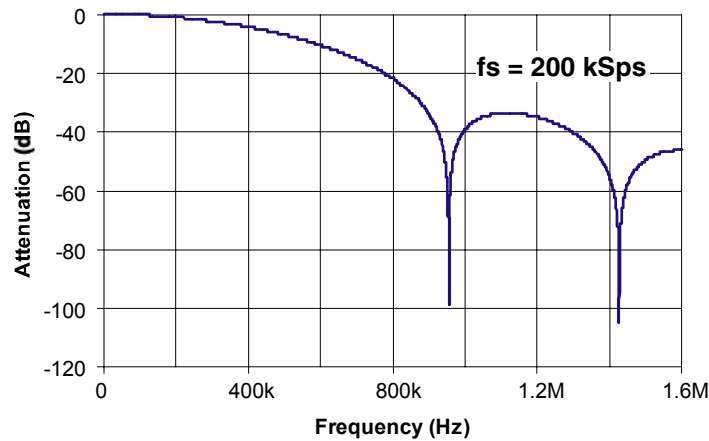

**Figure 13. CS5581 Spectral Response (DC to 8fs)**

### 3.11 Serial Port

The serial port on the CS5581 can operate in two different modes: synchronous self clock (SSC) mode & synchronous external clock (SEC) mode. The serial port must be placed into the SEC mode if the offset and gain registers of the converter are to be read or written. The converter must be idle when reading or writing to the on-chip registers.

#### 3.11.1 SSC Mode

If the SMODE pin is high (SMODE = VL), the serial port operates in the SSC (Synchronous Self Clock) mode. In the SSC mode the port shifts out conversion data words with SCLK as an output. SCLK is generated inside the converter from MCLK. Data is output from the SDO (Serial Data Output) pin. If  $\overline{CS}$  is high, the SDO and SCLK pins will stay in a high-impedance state. If  $\overline{CS}$  is low when  $\overline{RDY}$  falls, the conversion data word will be output from SDO MSB first. Data is output on the rising edge of SCLK and should be latched into the external logic on the subsequent rising edge of SCLK. When all bits of the conversion word are output from the port the  $\overline{RDY}$  signal will return to high.

#### 3.11.2 SEC Mode

If the SMODE pin is low (SMODE = VLR), the serial port operates in the SEC (Synchronous External Clock mode). In this mode, the user usually monitors  $\overline{RDY}$ . When  $\overline{RDY}$  falls at the end of a conversion, the conversion data word is placed into the output data register in the serial port.  $\overline{CS}$  is then activated low to enable data output. Note that  $\overline{CS}$  can be held low continuously if it is not necessary to have the SDO output operate in the high impedance state. When  $\overline{CS}$  is taken low (after  $\overline{RDY}$  falls) the conversion data word is then shifted out of the SDO pin by driving the SCLK pin from system logic external to the converter. Data bits are advanced on rising edges of SCLK and latched by the subsequent rising edge of SCLK.

If  $\overline{CS}$  is held low continuously, the  $\overline{RDY}$  signal will fall at the end of a conversion and the conversion data will be placed into the serial port. If the user starts a read, the user will maintain control over the serial port until the port is empty. However, if SCLK is not toggled, the converter will overwrite the conversion data at the completion of the next conversion. If  $\overline{CS}$  is held low and no read is performed,  $\overline{RDY}$  will rise just prior to the end of the next conversion and then fall to signal that new data has been written into the serial port.

### 3.12 Power Supplies & Grounding

The CS5581 can be configured to operate with its analog supply operating from 5V, or with its analog supplies operating from  $\pm 2.5V$ . The digital interface supports digital logic operating from either 1.8V, 2.5V, or 3.3V.

Figure 5 on page 17 illustrates the device configured to operate from  $\pm 2.5V$  analog. Figure 6 on page 18 illustrates the device configured to operate from 5V analog.

To maximize converter performance, the analog ground and the logic ground for the converter should be connected at the converter. In the dual analog supply configuration, the analog ground for the  $\pm 2.5V$  supplies should be connected to the VLR pin at the converter with the converter placed entirely over the analog ground plane.

In the single analog supply configuration (+5V), the ground for the +5V supply should be directly tied to the VLR pin of the converter with the converter placed entirely over the analog ground plane. Refer to Figure 6 on page 18.

### 3.13 Using the CS5581 in Multiplexing Applications

The CS5581 is a delta-sigma A/D converter. Delta-sigma converters use oversampling as means to achieve high signal to noise. This means that once a conversion is started the converter takes many samples to compute the resulting output word. The analog input for the signal to be converted must remain active during the entire conversion until  $\overline{\text{RDY}}$  falls.

The CS5581 can be used in multiplexing applications, but the system timing for changing the multiplexer channel and for starting a new conversion will depend upon the multiplexer system architecture.

The simplest system is illustrated in Figure 14. Any time the multiplexer is changed, the analog signal presented to the converter must fully settle. After the signal has settled, the  $\overline{\text{CONV}}$  signal is issued to the converter to start a conversion. Being a delta-sigma converter, the signal must remain present at the input of the converter until the conversion is completed. Once the conversion is completed,  $\overline{\text{RDY}}$  falls. At this time the multiplexer can be changed to the next channel and the data can be read from the serial port. The  $\overline{\text{CONV}}$  signal should be delayed until after the data is read and until the new analog signal has settled. In this configuration, the throughput of the converter will be dictated by the settling time of the analog input circuit and the conversion time of the converter. The conversion data can be read from the serial port after the multiplexer is changed to the new channel while the analog input signal is settling.

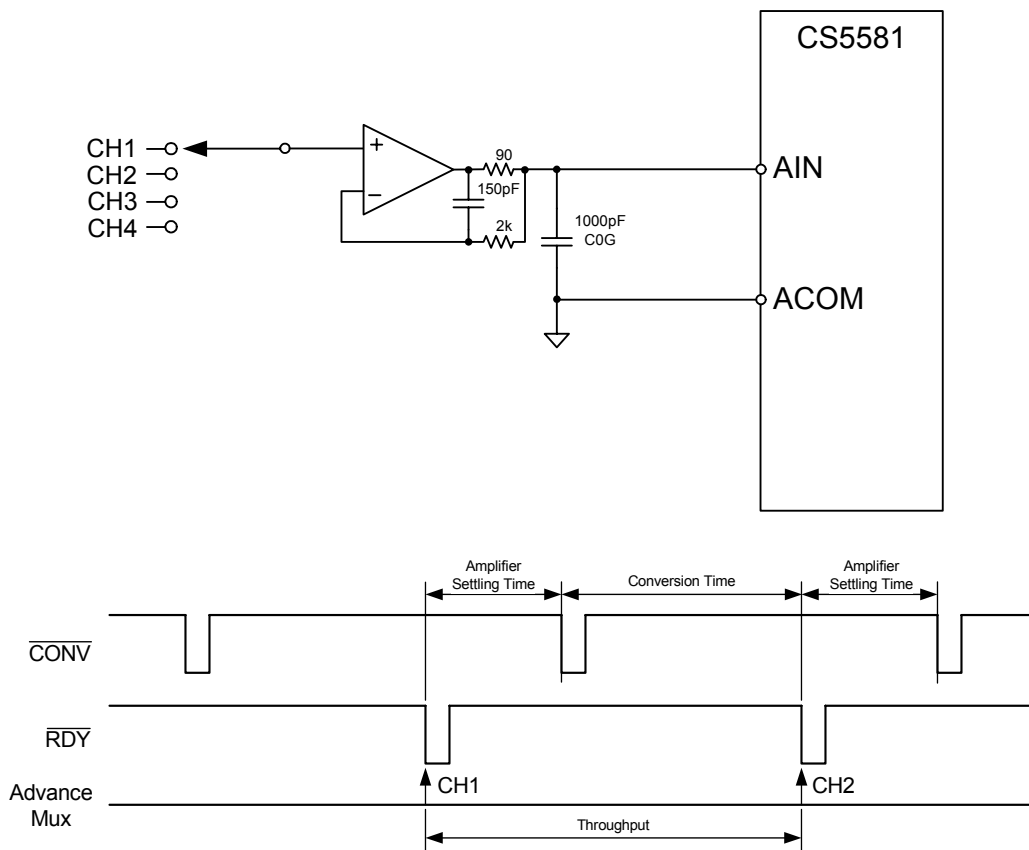

**Figure 14. Simple Multiplexing Scheme**

A more complex multiplexing scheme can be used to increase the throughput of the converter is illustrated in Figure 15. In this circuit, two banks of multiplexers are used.



At the same time the converter is performing a conversion on a channel from one bank of multiplexers, the second multiplexer bank is used to select the channel for the next conversion. This configuration allows the buffer amplifier for the second multiplexer bank to fully settle while a conversion is being performed on the channel from the first multiplexer bank. The multiplexer on the output of the buffer amplifier and the CONV signal can be changed at the same time in this configuration. This multiplexing architecture allows for maximum multiplexing throughput from the A/D converter. The following figure depicts the recommended analog input amplifier circuit.

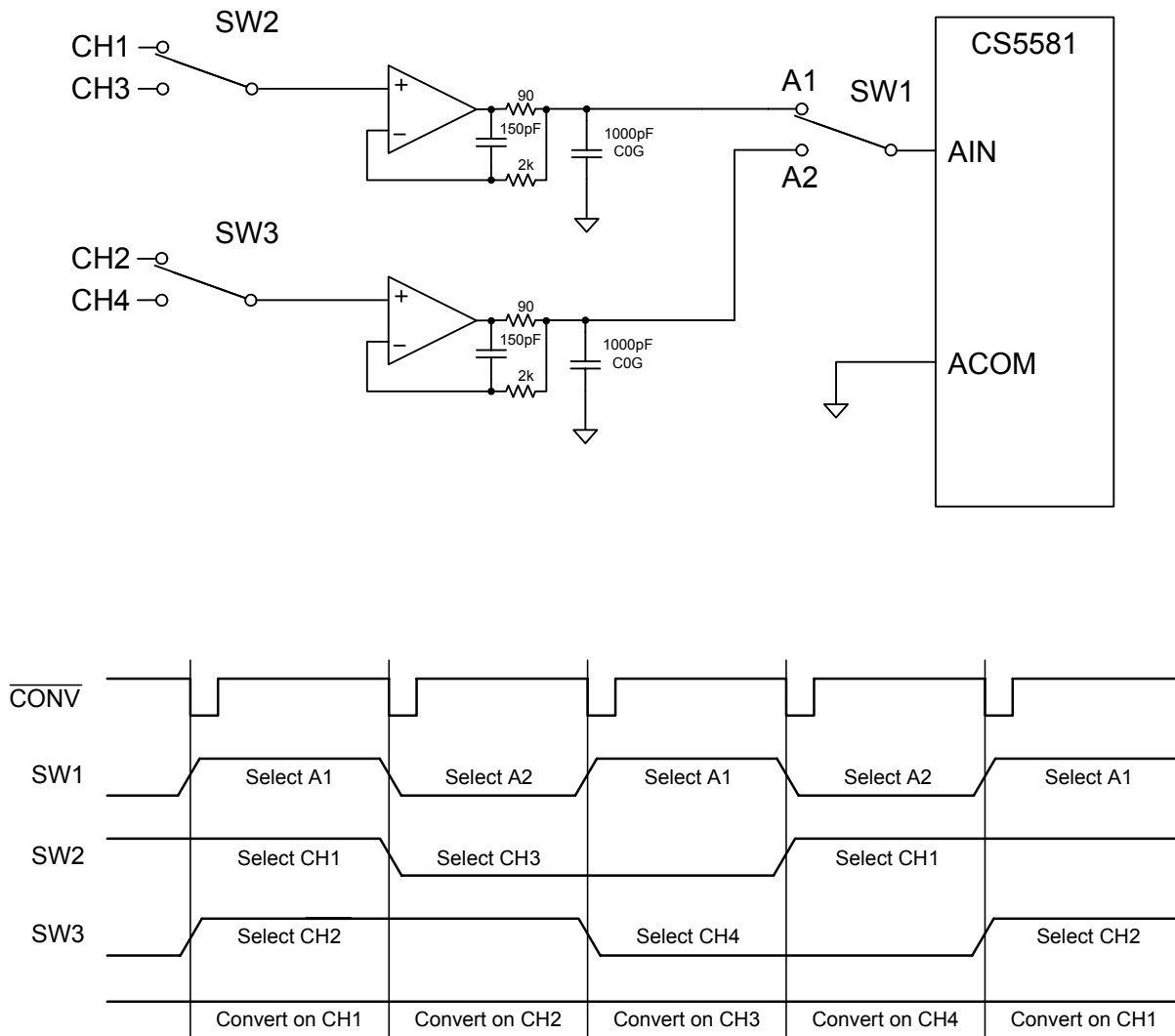

Figure 15. More Complex Multiplexing Scheme

### 3.14 Synchronizing Multiple Converters

Many measurement systems have multiple converters that need to operate synchronously. The converters should all be driven from the same master clock. In this configuration, the converters will convert synchronously if the same CONV signal is used to drive all the converters, and CONV falls on a falling edge of MCLK. If CONV is held low continuously, reset ( $\overline{\text{RST}}$ ) can be used to synchronize multiple converters if  $\overline{\text{RST}}$  is released on a falling edge of MCLK.

## 4. PIN DESCRIPTIONS

Chip Select	$\overline{\text{CS}}$	1 ●	24	$\overline{\text{RDY}}$	Ready
Factory Test	TST	2	23	SCLK	Serial Clock Input/Output
Serial Mode Select	SMODE	3	22	SDO	Serial Data Output
Analog Input	AIN	4	21	VL	Logic Interface Power
Analog Common	ACOM	5	20	VLR	Logic Interface Return
Negative Power 1	V1-	6	19	MCLK	Master Clock
Positive Power 1	V1+	7	18	V2-	Negative Voltage 2
Buffer Enable	BUFEN	8	17	V2+	Positive Voltage 2
Voltage Reference Input	VREF+	9	16	DCR	Digital Core Regulator
Voltage Reference Input	VREF-	10	15	CONV	Convert
Bipolar/Unipolar Select	BP/UP	11	14	CAL	Calibrate
Logic Interface Return 2	VLR2	12	13	RST	Reset

### $\overline{\text{CS}}$ – Chip Select, Pin 1

The Chip Select pin allows an external device to access the serial port. When held high, the SDO output will be held in a high-impedance output state.

### TST – Factory Test, Pin 2

For factory use only. Tie to VLR.

### SMODE – Serial Mode Select, Pin 3

The serial interface mode pin (SMODE) dictates whether the serial port behaves as a master or slave interface. If SMODE is tied high (to VL), the port will operate in the Synchronous Self-Clocking (SSC) mode. In SSC mode the port acts as a master in which the converter outputs both the SDO and SCLK signals. If SMODE is tied low (to VLR) the port will operate in the Synchronous External Clocking (SEC) mode. In SEC mode, the port acts as a slave in which the external logic or microcontroller generates the SCLK used to output the conversion data word from the SDO pin.

### AIN, ACOM – Differential Analog Input, Pin 4, 5

AIN and ACOM are the single-ended input and the analog return for the input signal, respectively.

### V1- – Negative Power 1, Pin 6

The V1- and V2- pins provide a negative supply voltage to the core circuitry of the chip. These two pins should be decoupled as shown in the application block diagrams. V1- and V2- should be supplied from the same source voltage. For single supply operation these two voltages are nominally 0 V (Ground). For dual supply operation they are nominally -2.5 V.

### V1+ – Positive Power 1, Pin 7

The V1+ and V2+ pins provide a positive supply voltage to the core circuitry of the chip. These two pins should be decoupled as shown in the application block diagrams. V1+ and V2+ should be supplied from the same source voltage. For single supply operation these two voltages are nominally +5 V. For dual supply operation they are nominally +2.5 V.

### BUFEN – Buffer Enable, Pin 8

Buffers on input pins AIN and ACOM are enabled if BUFEN is connected to V1+ and disabled if connected to V1-.

### VREF+, VREF- – Voltage Reference Input, Pin 9, 10

A differential voltage reference input on these pins functions as the voltage reference for the converter. The voltage between these pins can range between 2.4 volts and 4.2 volts, with 4.096 volts being the nominal reference voltage value.

**BP/UP – Bipolar/Unipolar Select, Pin 11**

The BP/UP pin determines the span and the output coding of the converter. When set high to select BP (bipolar), the input span of the converter is -2.048 volts to +2.048 volts (assuming the voltage reference is 4.096 volts) and outputs data is coded in two's complement format. When set low to select UP (unipolar), the input span is 0 to +2.048 and the output data is coded in binary format.

**RST – Reset, Pin 13**

Reset is necessary after power is initially applied to the converter. When the RST input is taken low, the logic in the converter will be reset. When RST is released to go high, certain portions of the analog circuitry are started. RDY falls when reset is complete.

**CAL – Calibrate, Pin 14**

After power is applied, a reset should be performed prior to calibration. After an initial reset, calibration can be performed at any time. Calibration can be initiated in either of two ways. If CAL is high when coming out of reset, (RST going high), a calibration will be performed. If RST is taken high with CAL low, a calibration is not performed, but calibration can be initiated by taking CAL high at any time the converter is idle. RDY will also fall when calibration is completed.

**CONV – Convert, Pin 15**

The CONV pin initiates a conversion cycle if taken low, unless a calibration cycle or a previous conversion is in progress. When the conversion cycle is completed, the conversion word is output to the serial port register and the RDY signal goes low. If CONV is held low and remains low when RDY falls another conversion cycle will be started.

**DCR – Digital Core Regulator, Pin 16**

DCR is the output of the on-chip regulator for the digital logic core. DCR should be bypassed with a capacitor to V2-. The DCR pin is not designed to power any external load.

**V2+ – Positive Power 2, Pin 17**

The V1+ and V2+ pins provide a positive supply voltage to the circuitry of the chip. These two pins should be decoupled as shown in the application block diagrams. V1+ and V2+ should be supplied from the same source voltage. For single supply operation these two voltages are nominally +5 V. For dual supply operation they are nominally +2.5 V.

**V2- – Negative Power 2, Pin 18**

The V1- and V2- pins provide a negative supply voltage to the circuitry of the chip. These two pins should be decoupled as shown in the application block diagrams. V1- and V2- should be supplied from the same source voltage. For single supply operation these two voltages are nominally 0 V (Ground). For dual supply operation they are nominally -2.5 V.

**MCLK – Master Clock, Pin 19**

The master clock pin (MCLK) is a multi-function pin. If tied low (MCLK = VLR) the on-chip oscillator will be enabled. If tied high (MCLK = VL), all clocks to the internal circuitry of the converter will stop. When MCLK is held high the internal oscillator will also be stopped. MCLK can also function as the input for an external CMOS-compatible clock that conforms to supply voltages on the VL and VLR pins.

**VLR2, VLR, VL – Logic Interface Power/Return, Pin 12, 20, 21**

VL and VLR are the supply voltages for the digital logic interface. VL and VLR can be configured with a wide range of common mode voltage. The following interface pins function from the VL/VLR supply: SMODE, CS, SCLK, TST, SDO, RDY, CONV, RST, CONV, CAL, BP/UP, and MCLK.

**SDO – Serial Data Output, Pin 22**

SDO is the output pin for the serial output port. Data from this pin will be output at a rate determined by SCLK and in a format determined by the BP/UP pin. Data is output MSB first and advances to the next data bit on the rising edges of SCLK. SDO will be in a high impedance state when  $\overline{CS}$  is high.

**SCLK – Serial Clock Input/Output, Pin 23**

The SMODE pin determines whether the SCLK signal is an input or an output signal. SCLK determines the rate at which data is clocked out of the SDO pin. If the converter is in SSC mode, the SCLK frequency will be determined by the master clock frequency of the converter (either MCLK or the internal oscillator). In SEC mode, the user determines the SCLK frequency. If SCLK is an output (SMODE = VL), it will be in a high-impedance state when  $\overline{CS}$  is high.

**$\overline{RDY}$  – Ready, Pin 24**

The  $\overline{RDY}$  signal rises when a calibration is initiated. When the calibration is near completion the state of  $\overline{CONV}$  is examined. If  $\overline{CONV}$  is high, the  $\overline{RDY}$  signal will fall upon the completion of calibration. If  $\overline{CONV}$  is low the converter will immediately start a conversion and  $\overline{RDY}$  will remain high until the conversion is completed. At the end of any conversion  $\overline{RDY}$  falls to indicate that a conversion word has been placed into the serial port.  $\overline{RDY}$  will return high after all data bits are shifted out of the serial port or two master clock cycles before new data becomes available if the  $\overline{CS}$  pin is inactive (high); or two master clock cycles before new data becomes available if the user holds  $\overline{CS}$  low but has not started reading the data from the converter when in SEC mode.

## 5. PACKAGE DIMENSIONS

### 24L SSOP PACKAGE DRAWING

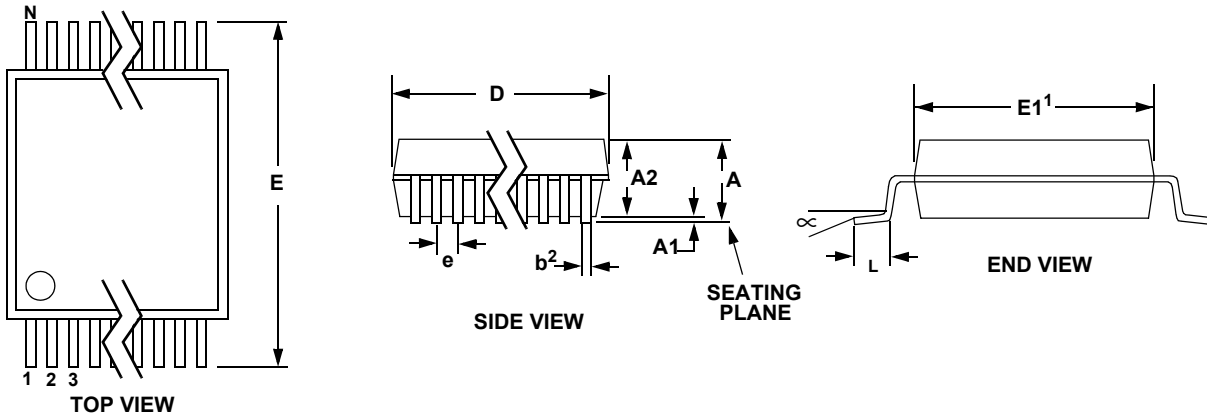

DIM	INCHES			MILLIMETERS			NOTE
	MIN	NOM	MAX	MIN	NOM	MAX	
A	--	--	0.084	--	--	2.13	
A1	0.002	0.006	0.010	0.05	0.13	0.25	
A2	0.064	0.068	0.074	1.62	1.73	1.88	
b	0.009	--	0.015	0.22	--	0.38	2,3
D	0.311	0.323	0.335	7.90	8.20	8.50	1
E	0.291	0.307	0.323	7.40	7.80	8.20	
E1	0.197	0.209	0.220	5.00	5.30	5.60	1
e	0.022	0.026	0.030	0.55	0.65	0.75	
L	0.025	0.03	0.041	0.63	0.75	1.03	
$\infty$	0°	4°	8°	0°	4°	8°	

**JEDEC #: MO-150**

Controlling Dimension is Millimeters.

- Notes:
1. "D" and "E1" are reference datums and do not include mold flash or protrusions, but do include mold mismatch and are measured at the parting line, mold flash or protrusions shall not exceed 0.20 mm per side.
  2. Dimension "b" does not include dambar protrusion/intrusion. Allowable dambar protrusion shall be 0.13 mm total in excess of "b" dimension at maximum material condition. Dambar intrusion shall not reduce dimension "b" by more than 0.07 mm at least material condition.
  3. These dimensions apply to the flat section of the lead between 0.10 and 0.25 mm from lead tips.

## 6. ORDERING INFORMATION

Model	Linearity	Temperature	Conversion Time	Throughput	Package
CS5581-ISZ	TBD	-40 to +85 °C	5 $\mu$ s	200 kSps	24-pin SSOP

## 7. ENVIRONMENTAL, MANUFACTURING, & HANDLING INFORMATION

Model Number	Peak Reflow Temp	MSL Rating*	Max Floor Life
CS5581-ISZ	260 °C	3	7 Days

\* MSL (Moisture Sensitivity Level) as specified by IPC/JEDEC J-STD-020.

## 8. REVISION HISTORY

Revision	Date	Changes
A1	AUG 2007	Advance release.

---

### Contacting Cirrus Logic Support

For all product questions and inquiries contact a Cirrus Logic Sales Representative.

To find the one nearest to you go to [www.cirrus.com](http://www.cirrus.com)

---

#### IMPORTANT NOTICE

"Advance" product information describes products that are in development and subject to development changes.

Cirrus Logic, Inc. and its subsidiaries ("Cirrus") believe that the information contained in this document is accurate and reliable. However, the information is subject to change without notice and is provided "AS IS" without warranty of any kind (express or implied). Customers are advised to obtain the latest version of relevant information to verify, before placing orders, that information being relied on is current and complete. All products are sold subject to the terms and conditions of sale supplied at the time of order acknowledgment, including those pertaining to warranty, indemnification, and limitation of liability. No responsibility is assumed by Cirrus for the use of this information, including use of this information as the basis for manufacture or sale of any items, or for infringement of patents or other rights of third parties. This document is the property of Cirrus and by furnishing this information, Cirrus grants no license, express or implied under any patents, mask work rights, copyrights, trademarks, trade secrets or other intellectual property rights. Cirrus owns the copyrights associated with the information contained herein and gives consent for copies to be made of the information only for use within your organization with respect to Cirrus integrated circuits or other products of Cirrus. This consent does not extend to other copying such as copying for general distribution, advertising or promotional purposes, or for creating any work for resale.

CERTAIN APPLICATIONS USING SEMICONDUCTOR PRODUCTS MAY INVOLVE POTENTIAL RISKS OF DEATH, PERSONAL INJURY, OR SEVERE PROPERTY OR ENVIRONMENTAL DAMAGE ("CRITICAL APPLICATIONS"). CIRRUS PRODUCTS ARE NOT DESIGNED, AUTHORIZED OR WARRANTED FOR USE IN AIRCRAFT SYSTEMS, MILITARY APPLICATIONS, PRODUCTS SURGICALLY IMPLANTED INTO THE BODY, AUTOMOTIVE SAFETY OR SECURITY DEVICES, LIFE SUPPORT PRODUCTS OR OTHER CRITICAL APPLICATIONS. INCLUSION OF CIRRUS PRODUCTS IN SUCH APPLICATIONS IS UNDERSTOOD TO BE FULLY AT THE CUSTOMER'S RISK AND CIRRUS DISCLAIMS AND MAKES NO WARRANTY, EXPRESS, STATUTORY OR IMPLIED, INCLUDING THE IMPLIED WARRANTIES OF MERCHANTABILITY AND FITNESS FOR PARTICULAR PURPOSE, WITH REGARD TO ANY CIRRUS PRODUCT THAT IS USED IN SUCH A MANNER. IF THE CUSTOMER OR CUSTOMER'S CUSTOMER USES OR PERMITS THE USE OF CIRRUS PRODUCTS IN CRITICAL APPLICATIONS, CUSTOMER AGREES, BY SUCH USE, TO FULLY INDEMNIFY CIRRUS, ITS OFFICERS, DIRECTORS, EMPLOYEES, DISTRIBUTORS AND OTHER AGENTS FROM ANY AND ALL LIABILITY, INCLUDING ATTORNEYS' FEES AND COSTS, THAT MAY RESULT FROM OR ARISE IN CONNECTION WITH THESE USES.

Cirrus Logic, Cirrus, and the Cirrus Logic logo designs are trademarks of Cirrus Logic, Inc. All other brand and product names in this document may be trademarks or service marks of their respective owners.