

REVISIONS												
LTR	DESCRIPTION	DATE	APPROVED									
A	Add vendor CAGE number 27014 to case outline 2. Editorial changes in figures 1, 2, 3, and 4. Change drawing CAGE to 67268.	29 JULY 87	<i>MAK</i>									

REV												
PAGE												
REV STATUS OF PAGES	REV	A	A	A	A	A	A	A	A	A	A	A
	PAGES	1	2	3	4	5	6	7	8	9	10	11

Defense Electronics Supply Center Dayton, Ohio Original date of drawing: 16 September 1986 AMSC N/A	PREPARED BY <i>Greg A. Pitz</i>	MILITARY DRAWING This drawing is available for use by all Departments and Agencies of the Department of Defense TITLE: MICROCIRCUITS, DIGITAL, HIGH-SPEED CMOS OCTAL D-TYPE FLIP-FLOP, MONOLITHIC SILICON DWG NO. 5962-86814
	CHECKED BY <i>DA DiCenzo</i>	
	APPROVED BY <i>Robert P. Evans</i>	
	SIZE A CODE IDENT. NO. 67268	
	REV A	PAGE 1 OF 12

5962-E496

DISTRIBUTION STATEMENT A. Approved for public release; distribution is unlimited.

DESC FORM 193
MAY 86

1. SCOPE

1.1 Scope. This drawing describes device requirements for class B microcircuits in accordance with 1.2.1 of MIL-STD-883, "Provisions for the use of MIL-STD-883 in conjunction with compliant non-JAN devices".

1.2 Part number. The complete part number shall be as shown in the following example:

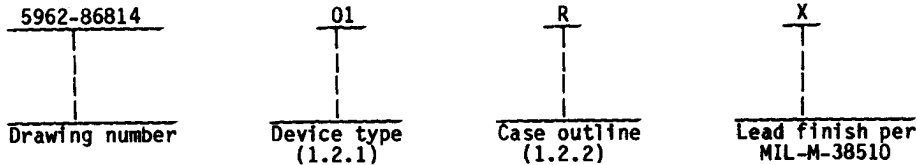

1.2 Part number. The complete part number shall be as shown in the following example:

1.2.1 Device type. The device type shall identify the circuit function as follows:

Device type	Generic number	Circuit function
01	54HC534	Flip-Flop, octal, D-type, 3-state with inverted outputs

1.2.2 Case outlines. The case outlines shall be as designated in appendix C of MIL-M-38510, and as follows:

Outline letter	Case outline
R	D-8 (20-lead, 1/4" x 1-1/16"), dual-in-line package
2	C-2 (20-terminal, .350" x .350"), square chip carrier package

1.3 Absolute maximum ratings. 1/

Supply voltage range - - - - -	-0.5 V dc to +7.0 V dc
DC input voltage - - - - -	-0.5 V dc to $V_{CC} + 0.5$ V dc
DC output voltage - - - - -	-0.5 V dc to $V_{CC} + 0.5$ V dc
Clamp diode current - - - - -	±20 mA
DC output current (per pin) - - - - -	±35 mA
DC V_{CC} or GND current (per pin) - - - - -	±70 mA
Storage temperature range - - - - -	-65°C to +150°C
Maximum power dissipation (P_D) 2/ - - - - -	500 mW
Lead temperature (soldering, 10 seconds) - - - - -	+260°C
Thermal resistance, junction-to-case (θ_{JC}):	
Case R - - - - -	See MIL-M-38510, appendix C
Case 2 - - - - -	60°C/W 3/
Junction temperature (T_J)- - - - -	+175°C

1/ Unless otherwise specified, all voltages are referenced to ground.

2/ For $T_C = +100^\circ\text{C}$ to $+125^\circ\text{C}$, derate linearly at 12 mW/°C.

3/ When a thermal resistance for this case is published in MIL-M-38510, appendix C, that value shall supersede the value indicated herein.

MILITARY DRAWING DEFENSE ELECTRONICS SUPPLY CENTER DAYTON, OHIO	SIZE A	CODE IDENT. NO. 67268	DWG NO. 5962-86814
		REV A	PAGE 2

1.4 Recommended operating conditions.

Supply voltage (V_{CC}) - - - - -	+2.0 V dc to +6.0 V dc
Case operating temperature range (T_C) - - - - -	-55°C to +125°C
Input rise or fall time :	
$V_{CC} = 2.0$ V - - - - -	0 to 100 ns
$V_{CC} = 4.5$ V - - - - -	0 to 500 ns
$V_{CC} = 6.0$ V - - - - -	0 to 400 ns
Minimum setup time, input D to clock (t_S):	
$T_C = +25^\circ\text{C}$:	
$V_{CC} = 2.0$ V - - - - -	100 ns
$V_{CC} = 4.5$ V - - - - -	20 ns
$V_{CC} = 6.0$ V - - - - -	17 ns
$T_C = -55^\circ\text{C to } +125^\circ\text{C}$:	
$V_{CC} = 2.0$ V - - - - -	150 ns
$V_{CC} = 4.5$ V - - - - -	30 ns
$V_{CC} = 6.0$ V - - - - -	26 ns
Minimum clock pulse width (t_M):	
$T_C = +25^\circ\text{C}$:	
$V_{CC} = 2.0$ V - - - - -	80 ns
$V_{CC} = 4.5$ V - - - - -	16 ns
$V_{CC} = 6.0$ V - - - - -	14 ns
$T_C = -55^\circ\text{C to } +125^\circ\text{C}$:	
$V_{CC} = 2.0$ V - - - - -	120 ns
$V_{CC} = 4.5$ V - - - - -	24 ns
$V_{CC} = 6.0$ V - - - - -	20 ns
Minimum hold time, clock to input D (t_H):	
$T_C = +25^\circ\text{C}$:	
$V_{CC} = 2.0$ V - - - - -	50 ns
$V_{CC} = 4.5$ V - - - - -	10 ns
$V_{CC} = 6.0$ V - - - - -	9 ns
$T_C = -55^\circ\text{C to } +125^\circ\text{C}$:	
$V_{CC} = 2.0$ V - - - - -	75 ns
$V_{CC} = 4.5$ V - - - - -	15 ns
$V_{CC} = 6.0$ V - - - - -	13 ns
Maximum frequency (f_{max})	
$T_C = +25^\circ\text{C}$:	
$V_{CC} = 2.0$ V - - - - -	6 MHz
$V_{CC} = 4.5$ V - - - - -	30 MHz
$V_{CC} = 6.0$ V - - - - -	35 MHz
$T_C = -55^\circ\text{C to } +125^\circ\text{C}$:	
$V_{CC} = 2.0$ V - - - - -	4 MHz
$V_{CC} = 4.5$ V - - - - -	20 MHz
$V_{CC} = 6.0$ V - - - - -	23 MHz

MILITARY DRAWING DEFENSE ELECTRONICS SUPPLY CENTER DAYTON, OHIO	SIZE A	CODE IDENT. NO. 67268	DWG NO. 5962-86814
		REV A	PAGE 3

DESC FORM 193A
FEB 86



2. APPLICABLE DOCUMENTS

2.1 Government specification and standard. Unless otherwise specified, the following specification and standard, of the issue listed in that issue of the Department of Defense Index of Specifications and Standards specified in the solicitation, form a part of this drawing to the extent specified herein.

SPECIFICATION

MILITARY

MIL-M-38510 - Microcircuits, General Specification for.

STANDARD

MILITARY

MIL-STD-883 - Test Methods and Procedures for Microelectronics.

(Copies of the specification and standard required by contractors in connection with specific acquisition functions should be obtained from the contracting activity or as directed by the contracting activity.)

2.2 Order of precedence. In the event of a conflict between the text of this drawing and the references cited herein, the text of this drawing shall take precedence.

3. REQUIREMENTS

3.1 Item requirements. The individual item requirements shall be in accordance with 1.2.1 of MIL-STD-883, "Provisions for the use of MIL-STD-883 in conjunction with compliant non-JAN devices" and as specified herein.

3.2 Design, construction, and physical dimensions. The design, construction, and physical dimensions shall be as specified in MIL-M-38510 and herein.

3.2.1 Terminal connections. The terminal connections shall be as specified on figure 1.

3.2.2 Truth tables. The truth table shall be as specified on figure 2.

3.2.3 Logic diagram. The logic diagram shall be as specified on figure 3.

3.2.4 Case outlines. The case outlines shall be in accordance with 1.2.2 herein.

3.3 Electrical performance characteristics. Unless otherwise specified, the electrical performance characteristics are as specified in table I and apply over the full recommended case operating temperature range.

3.4 Marking. Marking shall be in accordance with MIL-STD-883 (see 3.1 herein). The part shall be marked with the part number listed in 1.2 herein. In addition, the manufacturer's part number may also be marked as listed in 6.4 herein.



MILITARY DRAWING DEFENSE ELECTRONICS SUPPLY CENTER DAYTON, OHIO	SIZE A	CODE IDENT. NO. 67268	DWG NO. 5962-86814
		REV A	PAGE 4

DESC FORM 193A
FEB 86



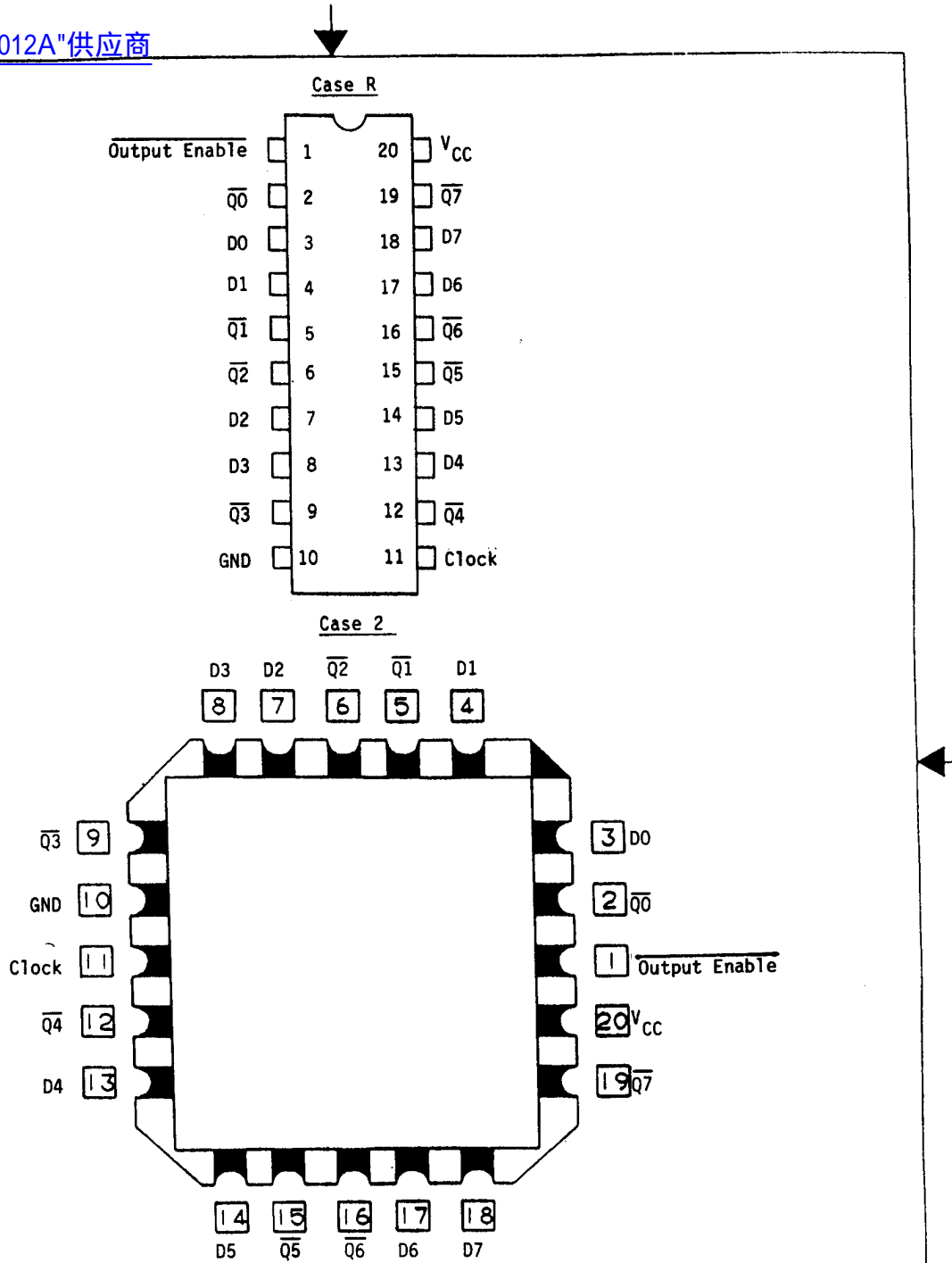

FIGURE 1. Terminal connections

MILITARY DRAWING DEFENSE ELECTRONICS SUPPLY CENTER DAYTON, OHIO	SIZE A	CODE IDENT. NO. 67268	DWG NO. 5962-86814
	REV A		PAGE 5

Inputs			Outputs
Output Enable	Clock	D	\bar{Q}
L	↑	H	L
L	↑	L	H
L	L	X	no change
H	X	X	Z
L = Low voltage level		X = don't care	
H = High voltage level		Z = high impedance	
		↑ = Low-to-high transition	

FIGURE 2. Truth table.

MILITARY DRAWING DEFENSE ELECTRONICS SUPPLY CENTER DAYTON, OHIO	SIZE A	CODE IDENT. NO. 67268	DWG NO. 5962-86814
		REV A	PAGE 6

DESC FORM 193A
FEB 86

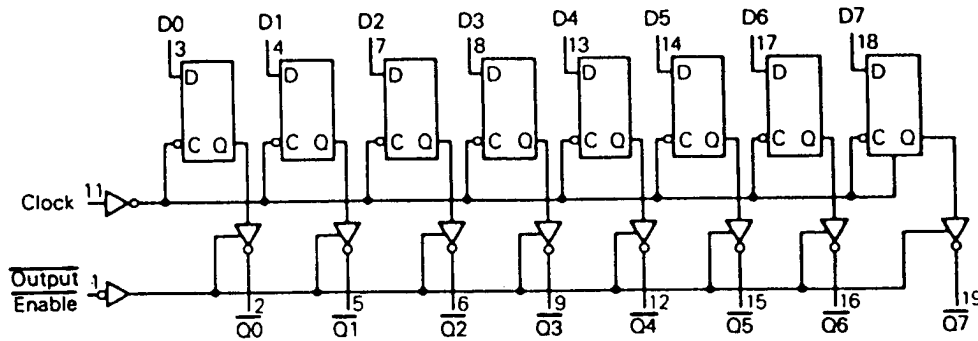

FIGURE 3. Logic diagram.

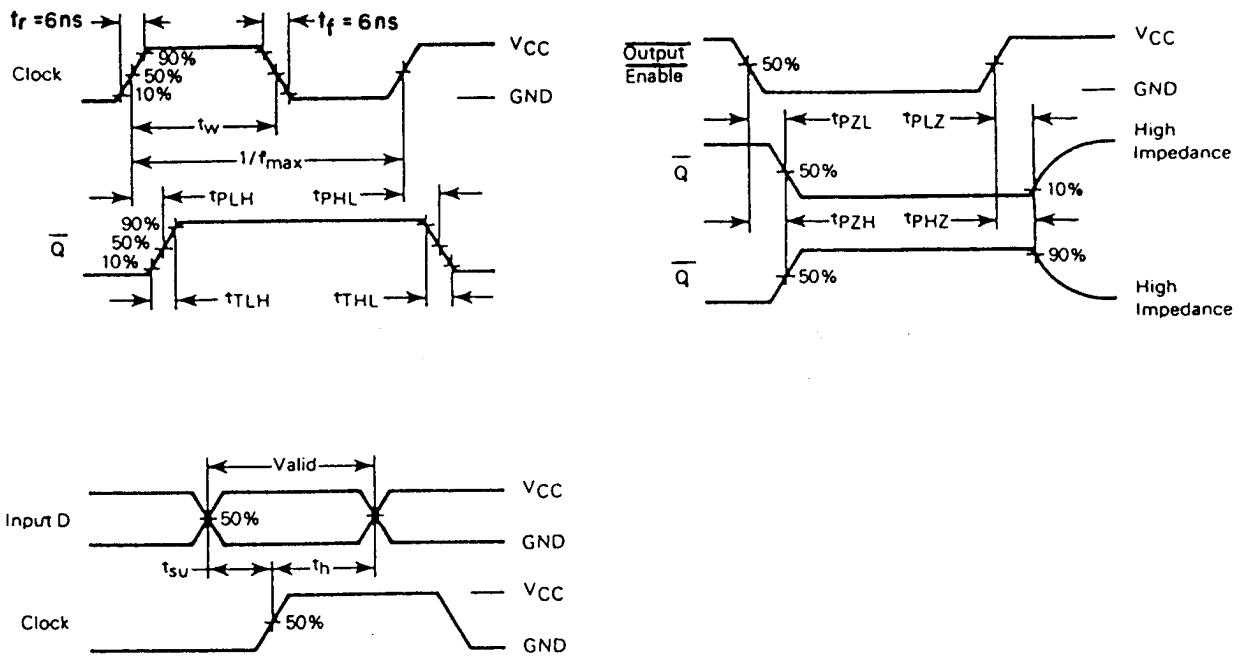

FIGURE 4. Switching waveforms.

MILITARY DRAWING DEFENSE ELECTRONICS SUPPLY CENTER DAYTON, OHIO	SIZE A	CODE IDENT. NO. 67268	DWG NO. 5962-86814
		REV A	PAGE 7

DESC FORM 193A
FEB 86

TABLE I. Electrical performance characteristics.

Test	Symbol	Conditions -55°C ≤ T _C ≤ +125°C 1/	Group A subgroups	Limits		Unit
				Min	Max	
High level output voltage	V _{OH}	V _{IN} = V _{IH} or V _{IL} I _{O1} ≤ 20 μA	1, 2, 3	V _{CC} = 2.0 V	1.9	V
				V _{CC} = 4.5 V	4.4	
				V _{CC} = 6.0 V	5.9	
		I _{O1} ≤ 6.0 mA	V _{CC} = 4.5 V	3.7		
		I _{O1} ≤ 7.8 mA	V _{CC} = 6.0 V	5.2		
Low level output voltage	V _{OL}	V _{IN} = V _{IH} or V _{IL} I _{O1} ≤ 20 μA	1, 2, 3	V _{CC} = 2.0 V	0.1	V
				V _{CC} = 4.5 V	0.1	
				V _{CC} = 6.0 V	0.1	
		I _{O1} ≤ 6.0 mA	V _{CC} = 4.5 V	0.4		
		I _{O1} ≤ 7.8 mA	V _{CC} = 6.0 V	0.4		
High level input voltage	V _{IH}	2/	1, 2, 3	V _{CC} = 2.0 V	1.5	V
		V _{CC} = 4.5 V		3.15		
		V _{CC} = 6.0 V		4.2		
Low level input voltage	V _{IL}	2/	1, 2, 3	V _{CC} = 2.0 V	0.3	V
		V _{CC} = 4.5 V		0.9		
		V _{CC} = 6.0 V		1.2		
Input capacitance	C _{IN}	V _{IN} = 0 V; T _C = +25°C see 4.3.1c	4		10	pF
Output capacitance	C _O	V _O = 0 V; T _C = +25°C see 4.3.1c	4		20	pF
Quiescent current	I _{CC}	V _{CC} = 6.0 V; V _{IN} = V _{CC} or GND	1, 2, 3		160	μA
Input leakage current	I _{IN}	V _{CC} = 6.0 V; V _{IN} = V _{CC} or GND	1, 2, 3		±1	μA
Functional tests		See 4.3.1d	7			
3-state output current	I _{OZ}	V _{IN} = V _{IH} or V _{IL} , V _O = V _{CC} or GND	1, 2, 3		±10	μA

See footnotes at end of table.

MILITARY DRAWING DEFENSE ELECTRONICS SUPPLY CENTER DAYTON, OHIO	SIZE A	CODE IDENT. NO. 67268	DWG NO. 5962-86814
		REV A	PAGE 8

DESC FORM 193A
FEB 86

TABLE 1. Electrical performance characteristics - Continued.

Test	Symbol	Conditions -55°C ≤ T _C ≤ +125°C 1/	Group A subgroups	Limits		Unit	
				Min	Max		
Propagation delay, clock to Q 3/ See figure 4	t _{PHL1} , t _{PLH1}	T _C = +25°C, C _L = 50 pF ±10%	V _{CC} = 2.0 V V _{CC} = 4.5 V V _{CC} = 6.0 V	9		180 36 31	ns
		T _C = -55°C, +125°C C _L = 50 pF ±10%	V _{CC} = 2.0 V V _{CC} = 4.5 V V _{CC} = 6.0 V	10, 11		270 54 46	ns
Propagation delay, output disable to Q 3/ See figure 4	t _{PLZ} , t _{PHZ}	T _C = +25°C, C _L = 50 pF ±10%	V _{CC} = 2.0 V V _{CC} = 4.5 V V _{CC} = 6.0 V	9		150 30 26	ns
		T _C = -55°C, +125°C C _L = 50 pF ±10%	V _{CC} = 2.0 V V _{CC} = 4.5 V V _{CC} = 6.0 V	10, 11		225 45 39	ns
Propagation delay, output enable to Q 3/ See figure 4	t _{pZL} , t _{pZH}	T _C = +25°C, C _L = 50 pF ±10%	V _{CC} = 2.0 V V _{CC} = 4.5 V V _{CC} = 6.0 V	9		175 35 30	ns
		T _C = -55°C, +125°C C _L = 50 pF ±10%	V _{CC} = 2.0 V V _{CC} = 4.5 V V _{CC} = 6.0 V	10, 11		265 53 45	ns
Transition time 4/ See figure 4	t _{TLH} , t _{THL}	T _C = +25°C, C _L = 50 pF ±10%	V _{CC} = 2.0 V V _{CC} = 4.5 V V _{CC} = 6.0 V	9		60 12 10	ns
		T _C = -55°C, +125°C C _L = 50 pF ±10%	V _{CC} = 2.0 V V _{CC} = 4.5 V V _{CC} = 6.0 V	10, 11		90 18 15	ns

- 1/ For a power supply of 5 V ±10% the worst case output voltage (V_{OH} and V_{OL}) occur for H_C at 4.5 V. Thus the 4.5 V values should be used when designing with this supply. Worst case V_{IH} and V_{IL} occur at V_{CC} = 5.5 V and 4.5 V respectively. (The V_{IH} value at 5.5 V is 3.85 V). The worst case leakage current (I_{IN}, I_{CC}, and I_{OZ}) occur for CMOS at the higher voltage and so the 6.0 V values should be used. Power dissipation capacitance (CPD), typically 50 pF, determines the no load dynamic power consumption, P_D = CPD V_{CC}²f + I_{CC} V_{CC}, and the no load dynamic current consumption, I_S = CPD V_{CC}²f + I_{CC}.
- 2/ Test not required if applied as a forcing function for V_{OH} or V_{OL}.
- 3/ AC testing at V_{CC} = 2.0 V and V_{CC} = 6.0 V shall be guaranteed, if not tested, to the specified parameters.
- 4/ Transition time, (t_{TLH}, t_{THL}), if not tested, shall be guaranteed to the specified parameters.

MILITARY DRAWING DEFENSE ELECTRONICS SUPPLY CENTER DAYTON, OHIO	SIZE A	CODE IDENT. NO. 67268	DWG NO. 5962-86814
		REV A	PAGE 9

3.5 Certificate of compliance. A certificate of compliance shall be required from a manufacturer in order to be listed as an approved source of supply in 6.4. The certificate of compliance submitted to DESC-ECS prior to listing as an approved source of supply shall state that the manufacturer's product meets the requirements of MIL-STD-883 (see 3.1 herein) and the requirements herein.

3.6 Certificate of conformance. A certificate of conformance as required in MIL-STD-883 (see 3.1 herein) shall be provided with each lot of microcircuits delivered to this drawing.

3.7 Notification of change. Notification of change to DESC-ECS shall be required in accordance with MIL-STD-883 (see 3.1 herein).

3.8 Verification and review. DESC, DESC's agent, and the acquiring activity retain the option to review the manufacturer's facility and applicable required documentation. Offshore documentation shall be made available onshore at the option of the reviewer.

4. QUALITY ASSURANCE PROVISIONS

4.1 Sampling and inspection. Sampling and inspection procedures shall be in accordance with section 4 of MIL-M-38510 to the extent specified in MIL-STD-883 (see 3.1 herein).

4.2 Screening. Screening shall be in accordance with method 5004 of MIL-STD-883, and shall be conducted on all devices prior to quality conformance inspection. The following additional criteria shall apply:

a. Burn-in test (method 1015 of MIL-STD-883).

(1) Test condition A, B, C, or D using the circuit submitted with the certificate of compliance (see 3.5 herein)

(2) $T_A = +125^{\circ}C$, minimum.

b. Interim and final electrical test parameters shall be as specified in table II herein, except interim electrical parameter tests prior to burn-in are optional at the discretion of the manufacturer.

4.3 Quality conformance inspection. Quality conformance inspection shall be in accordance with method 5005 of MIL-STD-883 including groups A, B, C, and D inspections. The following additional criteria shall apply.

4.3.1 Group A inspection.

a. Tests shall be as specified in table II herein.

b. Subgroups 5, 6, and 8 in table I, method 5005 of MIL-STD-883 shall be omitted.

c. Subgroup 4 (C_{IN} measurement) shall be measured only for the initial test and after process or design changes which may affect input capacitance. Generic test data may be used to satisfy the subgroup 4 requirements.

d. Subgroup 7 tests sufficient to verify truth table.

MILITARY DRAWING DEFENSE ELECTRONICS SUPPLY CENTER DAYTON, OHIO	SIZE	CODE IDENT. NO.	DWG NO.
	A	67268	5962-86814
		REV A	PAGE 10

4.3.2 Groups C and D inspections.

- a. End-point electrical parameters shall be as specified in table II herein.
- b. Steady-state life test (method 1005 of MIL-STD-883) conditions:
 - (1) Test condition A, B, C, or D using the circuit submitted with the certificate of compliance (see 3.5 herein).
 - (2) $T_A = +125^\circ\text{C}$, minimum.
 - (3) Test duration: 1,000 hours, except as permitted by appendix B of MIL-M-38510 and method 1005 of MIL-STD-883.

TABLE II. Electrical test requirements.

MIL-STD-883 test requirements	Subgroups (per method 5005, table I)
Interim electrical parameters (method 5004)	---
Final electrical test parameters (method 5004)	1*, 2, 9
Group A test requirements (method 5005)	1, 2, 3, 7, 9, 10, 11**
Groups C and D end-point electrical parameters (method 5005)	1, 2, 3
Additional electrical subgroups for group C periodic inspections	---

* PDA applies to subgroup 1.
 ** Subgroups 10 and 11, if not tested, shall be guaranteed to the specified limits in table I.

5. PACKAGING

5.1 Packaging requirements. The requirements for packaging shall be in accordance with MIL-M-38510.

6. NOTES

6.1 Intended use. Microcircuits conforming to this drawing are intended for use when military specifications do not exist and qualified military devices that will perform the required function are not available for OEM application. When a military specification exists and the product covered by this drawing has been qualified for listing on QPL-38510, the device specified herein will be inactivated and will not be used for new design. The QPL-38510 product shall be the preferred item for all applications.

MILITARY DRAWING DEFENSE ELECTRONICS SUPPLY CENTER DAYTON, OHIO	SIZE A	CODE IDENT. NO. 67268	DWG NO. 5962-86814
		REV A	PAGE 11

6.2 Replaceability. Replaceability is determined as follows:

- a. Microcircuits covered by this drawing will replace the same generic device covered by a contractor-prepared specification or drawing.
- b. When a QPL source is established, the part numbered device specified in this drawing will be replaced by the microcircuit identified as part number M38510/65605.

6.3 Comments. Comments on this drawing should be directed to DESC-ECS, Dayton, Ohio 45444, or telephone 513-296-5375.

6.4 Approved sources of supply. Approved sources of supply are listed herein. Additional sources will be added as they become available. The vendors listed herein have agreed to this drawing and a certificate of compliance (see 3.5 herein) has been submitted to DESC-ECS.

Military drawing part number	Vendor CAGE number	Vendor similar part number <u>1/</u>	Replacement military specification part number
5962-8681401RX	04713 27014 18714 01295	54HC534/BRAJC MM54HC534J/883 CD54HC534F/3A SNJ54HC534J	M38510/65605BRX
5962-86814012X	04713 01295 27014	54HC534M/B2CJC SNJ54HC534FK MM54HC534E/883	M38510/65605B2X

1/ Caution. Do not use this number for item acquisition. Items acquired to this number may not satisfy the performance requirements of this drawing.

<u>Vendor CAGE number</u>	<u>Vendor name and address</u>
04713	Motorola, Inc. 7402 South Price Road Tempe, AZ 85283
27014	National Semiconductor Corp 2900 Semiconductor Dr. Santa Clara, CA 95051
18714	RCA Corp Route 202 Somerville, NJ 08876
01295	Texas Instruments Inc P. O. Box 6448 Midland, TX 79701

MILITARY DRAWING DEFENSE ELECTRONICS SUPPLY CENTER DAYTON, OHIO	SIZE A	CODE IDENT. NO. 67268	DWG NO. 5962-86814
		REV A	PAGE 12

DESC FORM 193A
FEB 86

011968 _ _ _