

## OVERVIEW

The SM5304AV is a  $75\Omega$  terminating resistance drive video buffer with built-in analog filter. The filter cutoff frequency, controlled by the resistance connected to RFC pin, can be set to match any system resolution. The output buffer can be selected 0dB, 6dB, and 12dB. The feedback point occurs after the external coupling capacitors, and the coupling capacitances can be reduced.

## FEATURES

- $5V \pm 10\%$  supply voltage
- Adjustable cutoff frequency using external resistor
- 0dB, 6dB, 12dB selectable gain using logic signal
- $\pm 0.5\text{dB}$  output gain error
- Two systems (two load resistances) can be driven
- 0.7% output signal harmonic distortion
- Sag compensation circuit built-in
- Package: 8-pin VSOP (Pb free)

## APPLICATIONS

- DVD
- Digital still camera
- Digital VHS

## ORDERING INFORMATION

Device	Package
SM5304AV	8-pin VSOP

## PINOUT

(Top view)

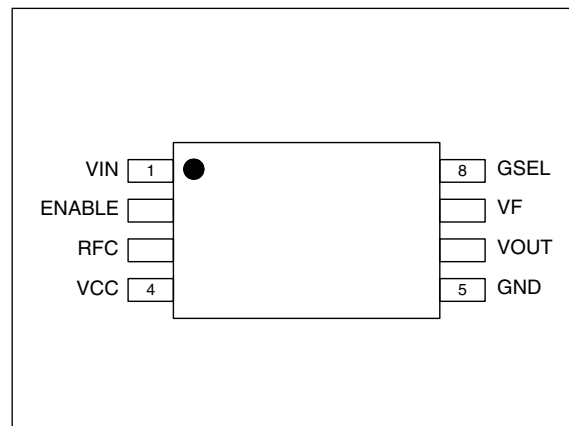

## PACKAGE DIMENSIONS

(Unit: mm)

Weight: 0.04g

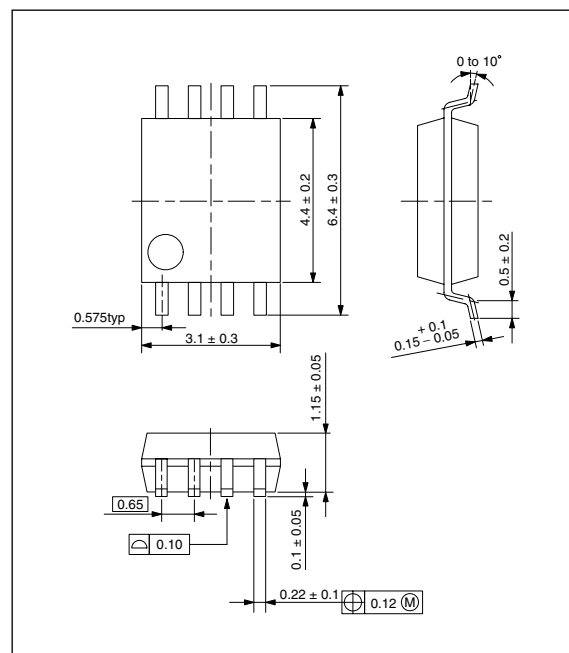

## BLOCK DIAGRAM

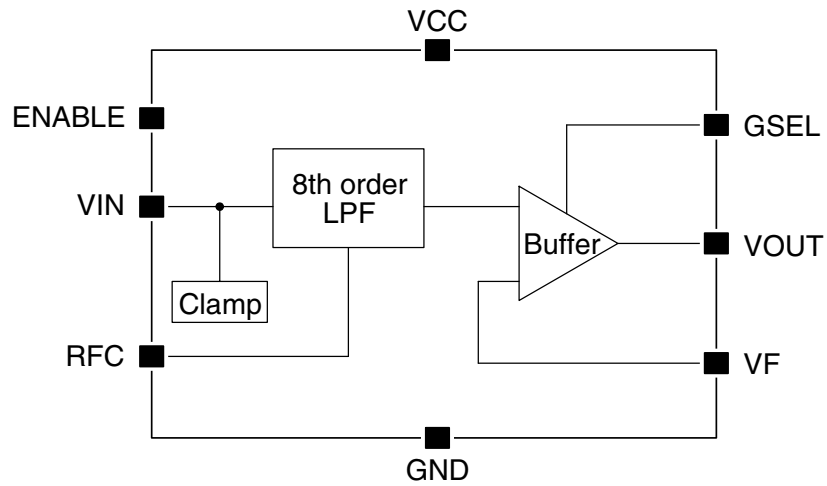

## PIN DESCRIPTION

Number	Name	I/O <sup>1</sup>	A/D <sup>2</sup>	Description
1	VIN	I	A	Input signal pin
2	ENABLE	I	D	Enable signal input pin (with pull-down resistor)
3	RFC	O	A	LPF cutoff frequency set pin
4	VCC	-	-	5V supply pin
5	GND	-	-	Ground pin
6	VOUT	O	A	Output signal pin
7	VF	I	A	Output signal feedback pin for sag compensation circuit
8	GSEL	I	D	Gain set signal input pin

1. I: input, O: output
2. A: analog, D: digital

## SPECIFICATIONS

### Absolute Maximum Ratings

Parameter	Symbol	Condition	Rating	Unit
Supply voltage range	$V_{CC}$		- 0.3 to 7	V
Storage temperature range	$T_{STG}$		- 55 to + 125	°C
Power dissipation	$P_D$	$\theta_{ja} = 214^\circ\text{C/W}$ (Note 1)	300	mW
Junction temperature	$T_j$		125	°C

(Note 1)  $T_j$  is calculated by  $T_j = P_D \times \theta_{ja} + T_a$  ( $P_D$ : Power dissipation (=  $V_{CC} \times I_{CC}$ ),  $\theta_{ja}$ : Thermal resistance,  $T_a$ : Ambient temperature).  
 $\theta_{ja}$  is measured value in the mounting condition which NPC specified. (glass epoxy board, board size: 40mm × 40mm, wiring density: 10%, still air)

### Recommended Operating Conditions

Parameter	Symbol	Condition	Rating	Unit
Supply voltage range	$V_{CC}$		4.5 to 5.5	V
Operating temperature range	$T_a$		- 40 to 85	°C

### Digital Characteristics

$V_{CC} = 5.0\text{V}$ ,  $T_a = 25^\circ\text{C}$ , unless otherwise noted.

Parameter	Symbol	Condition	Rating			Unit	Test level
			min	typ	max		
HIGH-level input voltage 1	$V_{IH1}$	ENABLE pin	2.4	-	-	V	I
LOW-level input voltage 1	$V_{IL1}$	ENABLE pin	-	-	0.8	V	I
HIGH-level input voltage 2	$V_{IH2}$	GSEL pin	$V_{CC} - 0.5$	-	-	V	I
LOW-level input voltage 2	$V_{IL2}$	GSEL pin	-	-	0.5	V	I
Open-circuit input voltage	$V_{OPEN}$	GSEL pin	$V_{CC}/2 - 0.5$	-	$V_{CC}/2 + 0.5$	V	I
HIGH-level input current 1	$I_{IH1}$	ENABLE pin, $V_{IN} = V_{CC}$	-	100	200	μA	I
Input leakage current 1	$I_{LL1}$	ENABLE pin, $V_{IN} = 0\text{V}$	-	-	1	μA	I
Input leakage current 2	$I_{LL2}$	GSEL pin, ENABLE = "LOW", $V_{IN} = 0\text{V}$	-	-	1	μA	I
HIGH-level input current 2	$I_{IH2}$	GSEL pin, ENABLE = "HIGH", $V_{IN} = V_{CC}$	-	250	400	μA	I
LOW-level input current 2	$I_{IL2}$	GSEL pin, ENABLE = "HIGH", $V_{IN} = 0\text{V}$	-	250	400	μA	I
Pull-down resistance 1	$R_{PD1}$	ENABLE pin	40	50	60	kΩ	I
Pull-down resistance 2	$R_{PD2}$	GSEL pin when ENABLE = "LOW"	16	20	24	kΩ	I

**Electrical Characteristics**

V<sub>CC</sub> = 5.0V, Ta = 25°C, unless otherwise noted, See Measurement circuit.

Parameter	Symbol	Condition	Rating			Unit	Test level
			min	typ	max		
Current consumption 1	I <sub>CC1</sub>	V <sub>CC</sub> = 4.5 to 5.5V, R <sub>FC</sub> = 2.7kΩ, Ta = -40 to 85°C, ENABLE = "HIGH"	-	41	52	mA	II
Current consumption 2	I <sub>CC2</sub>	V <sub>CC</sub> = 4.5 to 5.5V, R <sub>FC</sub> = 4.3kΩ, Ta = -40 to 85°C, ENABLE = "HIGH"	-	39	49	mA	II
Current consumption 3	I <sub>CC3</sub>	ENABLE = "LOW", GSEL = "LOW"	-	-	10	μA	I
Signal gain 1	A <sub>V1</sub>	GSEL = "LOW", R <sub>FC</sub> = 4.3kΩ, f = 1MHz	5.7	6.2	6.7	dB	I
Signal gain 2	A <sub>V2</sub>	GSEL = "Open cct", R <sub>FC</sub> = 4.3kΩ, f = 1MHz	-0.3	0.2	0.7	dB	I
Signal gain 3	A <sub>V3</sub>	GSEL = "HIGH", R <sub>FC</sub> = 4.3kΩ, f = 1MHz	11.5	12.0	12.5	dB	I
Input voltage range	V <sub>IN</sub>	AC-coupled input, f = 100kHz	1.4	-	-	Vp-p	I
Maximum output voltage	V <sub>out</sub>	Output conditions shown in Typical Connection	2.4	-	-	Vp-p	I
Clamp voltage	V <sub>CLMP</sub>		0.9	1.2	1.45	V	I
Overshoot/ Undershoot <sup>1</sup>	V <sub>OS</sub>		-	4.0	-	%	III
Output harmonic distortion	T <sub>HD</sub>	f = 1MHz, V <sub>out</sub> = 2Vp-p, R <sub>FC</sub> = 4.3kΩ	-	0.7	-	%	III
Cutoff frequency control range	f <sub>C</sub>		2	-	10	MHz	I
Resistor (R <sub>FC</sub> ) value range <sup>2</sup>	R <sub>FC</sub>		2.7	-	18	kΩ	I
Cutoff frequency error	ΔF <sub>C</sub>		-	-	± 15	%	I
4fc attenuation	f <sub>SB</sub>	f ≥ 4fc	-	-70	-	dB	III
Group delay variation	ΔT <sub>PD</sub>	R <sub>FC</sub> = 4.3kΩ, 100kHz and 5MHz group delay difference	-	12	-	ns	III

1. The percentage output pulse overshoot when R<sub>FC</sub> = 4.3kΩ, gain = 6dB, and input pulse = 1Vp-p (rise and fall times = 100ns).
2. Refer to "R<sub>FC</sub> Frequency Control" for the Cutoff frequency vs. R<sub>FC</sub> characteristics.

**Test level**

- I : Valid for 100% product tests conducted at Ta = 25°C
- II : 100% valid for alternative tests conducted at Ta = 25°C
- III: Guaranteed based on design and characteristics evaluation

**Measurement circuit**

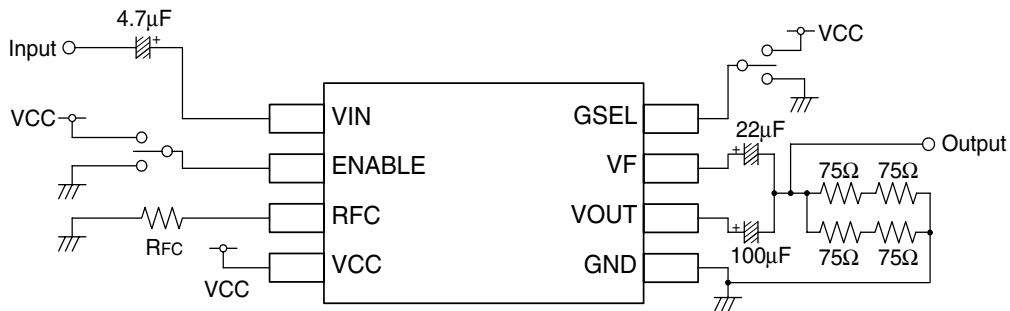

## FUNCTIONAL DESCRIPTION

### R<sub>FC</sub> Frequency Control

#### Characteristics

The cutoff frequency ( $f_c$ ) is controlled by the resistor connected to RFC pin (R<sub>FC</sub>). The characteristics about  $f_c$  versus R<sub>FC</sub> is shown in table 1.

Table 1. R<sub>FC</sub> and frequency control range

R <sub>FC</sub> [kΩ]	Cutoff frequency [MHz]
18	1.9
15	2.3
12	2.8
10	3.3
8.2	3.9
6.8	4.6
5.6	5.5
4.7	6.4
4.3	6.9
3.9	7.5
3.3	8.7
2.7	10.5

#### Adjustment methods

It can set up by the following methods. Since resistance affects cutoff frequency, please use a high precise thing.

- Fixed resistor

The frequency can be adjusted using an external resistor connected to RFC.

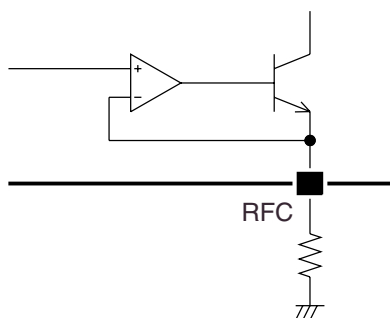

■ Variable resistor

The frequency can be adjusted using a preset variable resistor VR connected to RFC.

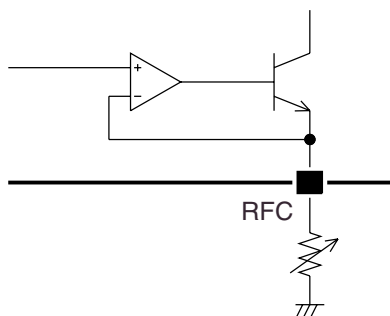

■ Voltage control

The frequency can be adjusted by voltage control of the resistor connected to RFC using a DC voltage supply (for example, using a DAC). In this case, the adjusting voltage must be controlled such that it does not exceed the RFC pin voltage (1.5V typ).

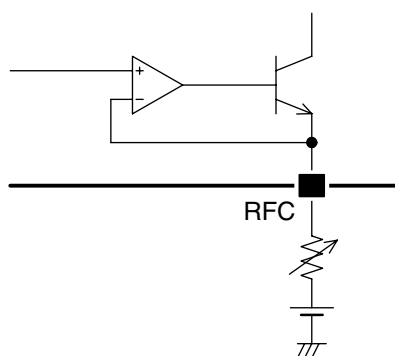

■ Resistor switch control

The frequency can be adjusted by switching the resistance connected to RFC using logic voltage control.

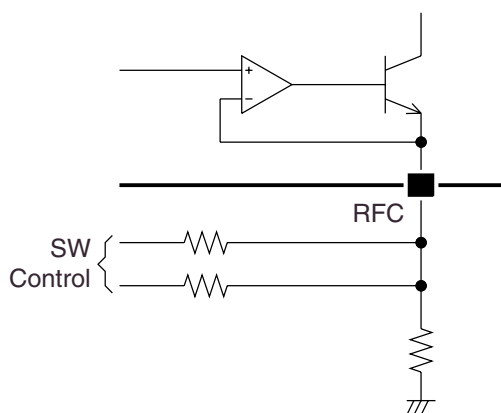

### Gain Control Function and Enable Function

ENABLE pin	GSEL pin	Gain setting
HIGH (Enable)	LOW	6dB
	Open	0dB
	HIGH	12dB
LOW (Disable)	LOW	High impedance output
	Open	
	HIGH	

When setting GSEL pin to open, in order to prevent incorrect operation by the external noise, it recommends connecting a capacitor between GSEL pin and GND pin.

### Equivalent circuit

The equivalent circuit of GSEL pin and ENABLE pin is shown in figure. GSEL pin is connected only to pull-down resistor in the state of disable.

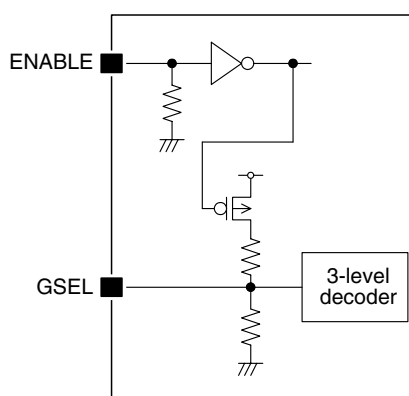

**TYPICAL CHARACTERISTICS**

$V_{CC} = 5.0V$ ,  $R_{FC} = 4.3k\Omega$ ,  $T_a = 25^\circ C$ , unless otherwise noted.

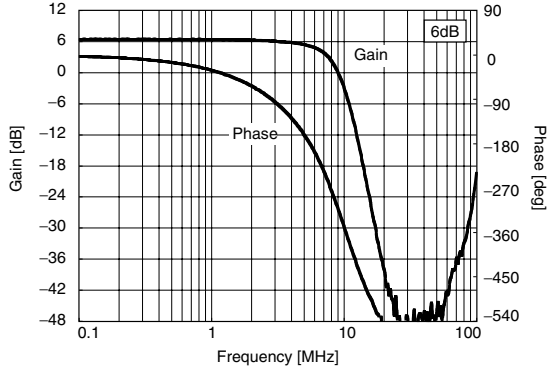

Figure 1. Phase vs Frequency

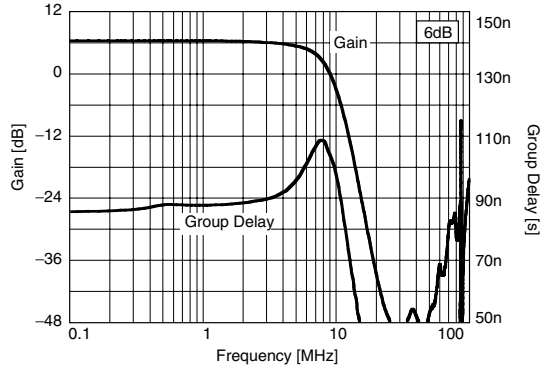

Figure 2. Group Delay vs Frequency

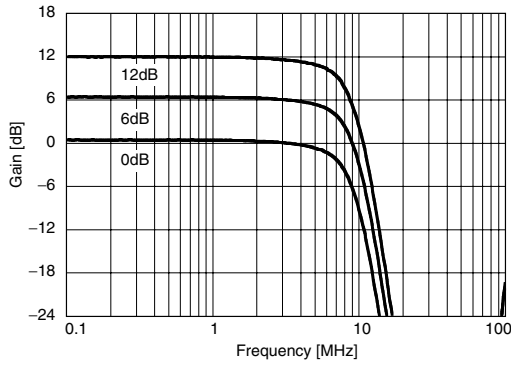

Figure 3. Gain vs Frequency ( $R_{fc} = 4.3k\Omega$ )

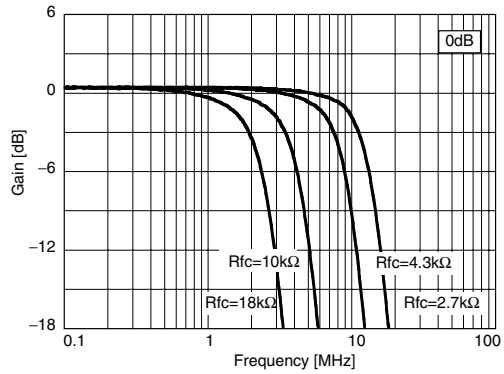

Figure 4. Gain vs Frequency (0dB)

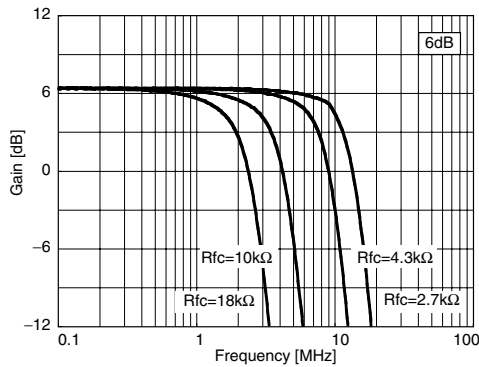

Figure 5. Gain vs Frequency (6dB)

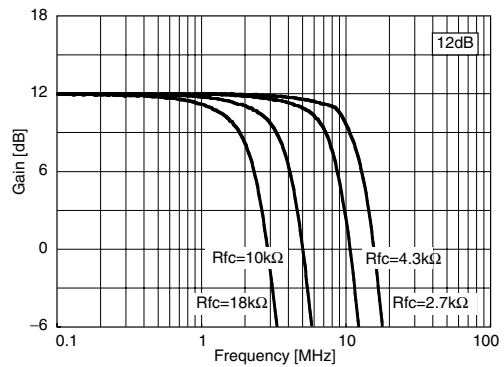

Figure 6. Gain vs Frequency (12dB)



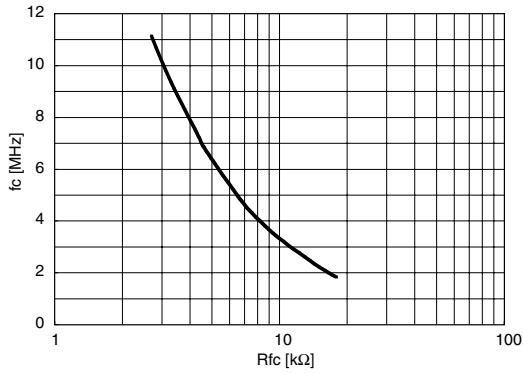

Figure 7.  $f_c$  vs  $R_{fc}$

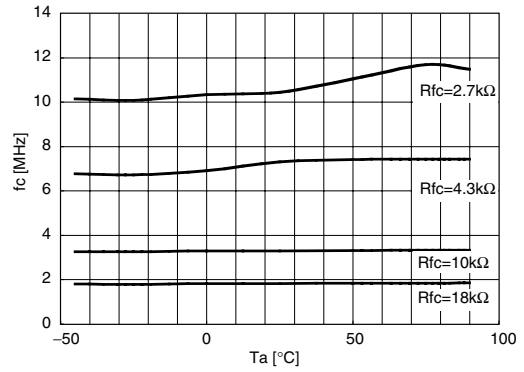

Figure 8.  $f_c$  vs  $T_a$

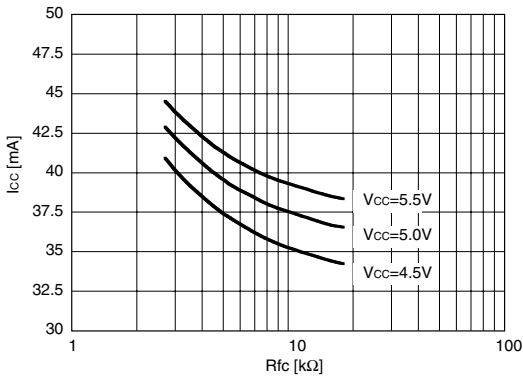

Figure 9.  $I_{CC}$  vs  $R_{fc}$

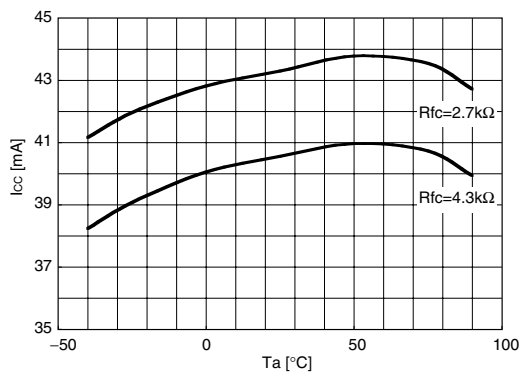

Figure 10.  $I_{CC}$  vs  $T_a$

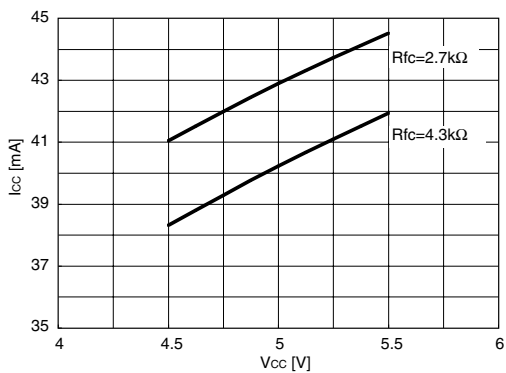

Figure 11.  $I_{CC}$  vs  $V_{CC}$

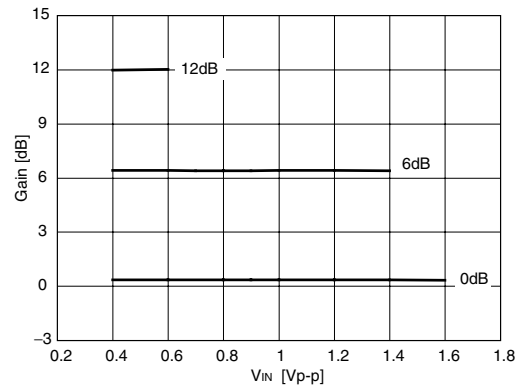

Figure 12. Gain vs  $V_{IN}$

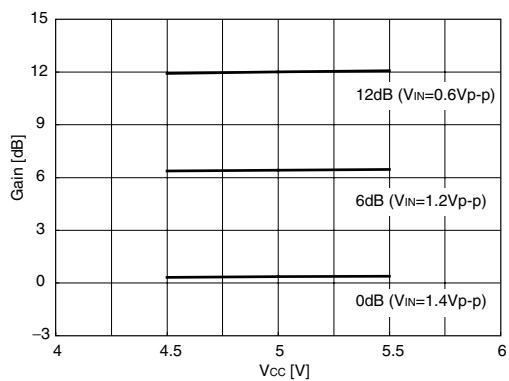

Figure 13. Gain vs V<sub>CC</sub>

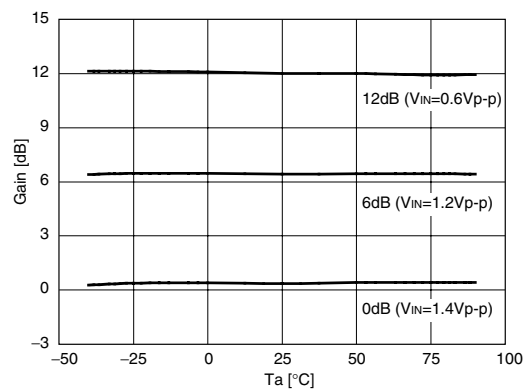

Figure 14. Gain vs Ta

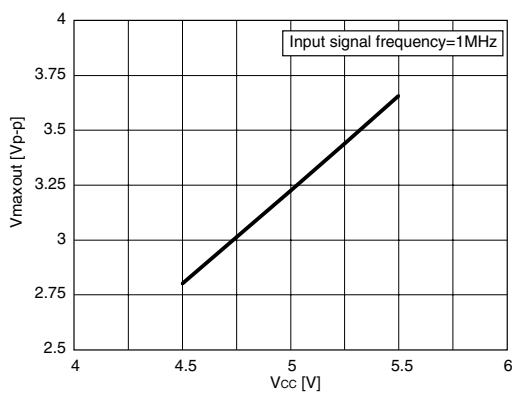
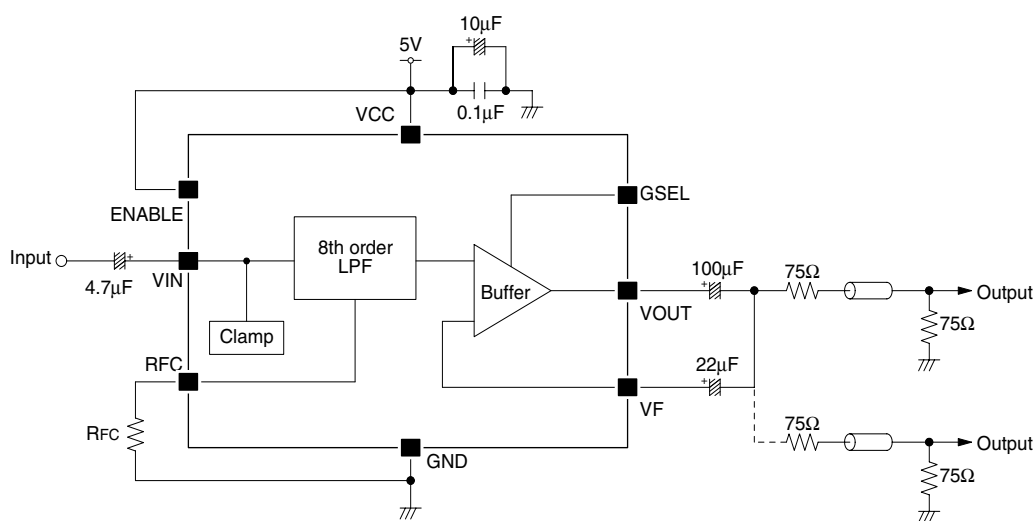

Figure 15. V<sub>maxout</sub> vs V<sub>CC</sub>

## TYPICAL CONNECTION



## NOTES ON USE

### Capacitors Between Power Supply Pin

Please be sure to connect a capacitor between power supply pin (VCC, GND) for preventing the oscillation of an output and supplying a power supply stable. Electrolytic capacitor about 1μF to 10μF and ceramic capacitor about 0.01μF to 0.1μF are recommended. Please connect a ceramic capacitor to near between power supply pin, shown in a figure.

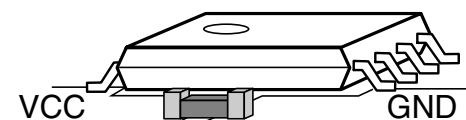

### Range of Power Dissipation and Ambient Temperature

Operating condition range (power supply and ambient temperature) which is not exceeded package power dissipation and package junction temperature shown in the item of Absolute Maximum Rating are shown in a figure. However this range is calculated from the package thermal resistance under the mounting conditions which NPC specified, and when mounting conditions differ from this condition, it does not become such.

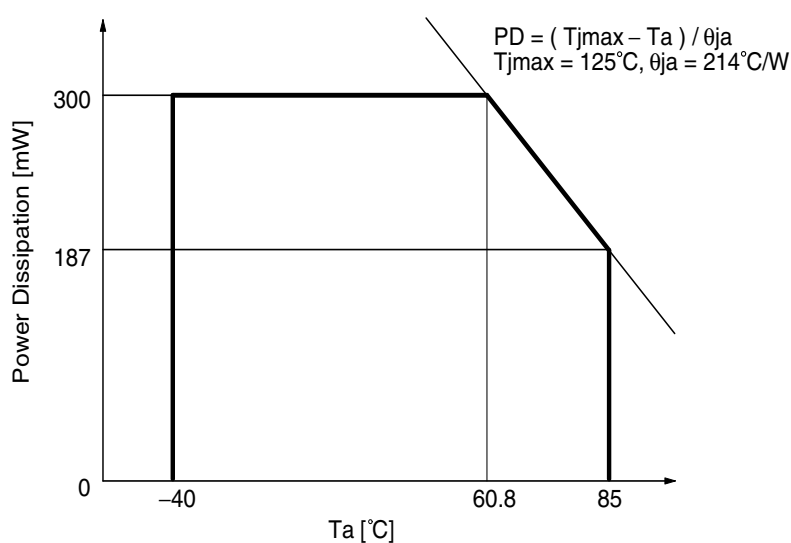

#### Mounting conditions

- glass epoxy board
- board size: 40mm × 40mm
- wiring density: 10%
- still air

The following method is effective, in order to lower thermal resistance and to prevent the rise of junction temperature.

- Wiring area connected to the pin of SM5304AV is made widely.
- To cool down, use the cooling fan etc.

Please pay your attention to the following points at time of using the products shown in this document.

The products shown in this document (hereinafter "Products") are not intended to be used for the apparatus that exerts harmful influence on human lives due to the defects, failure or malfunction of the Products. Customers are requested to obtain prior written agreement for such use from NIPPON PRECISION CIRCUITS INC. (hereinafter "NPC"). Customers shall be solely responsible for, and indemnify and hold NPC free and harmless from, any and all claims, damages, losses, expenses or lawsuits, due to such use without such agreement. NPC reserves the right to change the specifications of the Products in order to improve the characteristic or reliability thereof. NPC makes no claim or warranty that the contents described in this document dose not infringe any intellectual property right or other similar right owned by third parties. Therefore, NPC shall not be responsible for such problems, even if the use is in accordance with the descriptions provided in this document. Any descriptions including applications, circuits, and the parameters of the Products in this document are for reference to use the Products, and shall not be guaranteed free from defect, inapplicability to the design for the mass-production products without further testing or modification. Customers are requested not to export or re-export, directly or indirectly, the Products to any country or any entity not in compliance with or in violation of the national export administration laws, treaties, orders and regulations. Customers are requested appropriately take steps to obtain required permissions or approvals from appropriate government agencies.

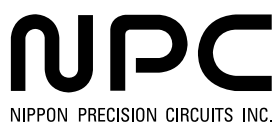

NIPPON PRECISION CIRCUITS INC.

4-3, Fukuzumi 2-chome, Koto-ku,  
Tokyo 135-8430, Japan  
Telephone: +81-3-3642-6661  
Facsimile: +81-3-3642-6698  
<http://www.npc.co.jp/>  
Email: [sales@npc.co.jp](mailto:sales@npc.co.jp)

NC0118AE 2003.02