

NPN-Silizium-Fototransistor in SMT-Gehäuse mit Linse Silicon NPN Phototransistor in SMT-Package with lens

SFH 3219



Wesentliche Merkmale

- TOPLED mit Linse
- Speziell geeignet für Anwendungen im Bereich von 430 nm bis 1150 nm
- Hohe Linearität
- Für alle Lötverfahren geeignet
- Gehäusegleich mit SFH 4209, SFH 4219, SFH 4289

Anwendungen

- Miniaturlichtschranken für Gleich- und Wechsellichtbetrieb
- Industrieelektronik
- „Messen/Steuern/Regeln“
- Automobiltechnik
- Sensorik

Features

- TOPLED with lens
- Especially suitable for applications from 430 nm to 1150 nm
- High linearity
- Suitable for all soldering methods
- Same package as SFH 4209, SFH 4219, SFH 4289

Applications

- Miniature photointerrupters
- Industrial electronics
- For control and drive circuits
- Automotive technology
- Sensor technology

Typ Type	Bestellnummer Ordering Code
SFH 3219	Q62702-P5551

Grenzwerte
Maximum Ratings

Bezeichnung Parameter	Symbol Symbol	Wert Value	Einheit Unit
Betriebs- und Lagertemperatur Operating and storage temperature range	$T_{op}; T_{stg}$	- 40 ... + 100	°C
Kollektor-Emitterspannung Collector-emitter voltage	V_{CE}	35	V
Kollektorstrom Collector current	I_C	15	mA
Kollektorspitzenstrom, $\tau < 10 \mu s$ Collector surge current	I_{CS}	75	mA
Verlustleistung, $T_A = 25 \text{ }^\circ\text{C}$ Total power dissipation	P_{tot}	165	mW
Wärmewiderstand für Montage auf PC-Board Thermal resistance for mounting on pcb	R_{thJA}	450	K/W

Kennwerte ($T_A = 25\text{ °C}$, $\lambda = 950\text{ nm}$)

Characteristics

Bezeichnung Parameter	Symbol Symbol	Wert Value	Einheit Unit
Wellenlänge der max. Fotoempfindlichkeit Wavelength of max. sensitivity	$\lambda_{S\text{ max}}$	990	nm
Spektraler Bereich der Fotoempfindlichkeit $S = 10\%$ von S_{max} Spectral range of sensitivity $S = 10\%$ of S_{max}	λ	430 ... 1150	nm
Bestrahlungsempfindliche Fläche ($\varnothing 240\text{ }\mu\text{m}$) Radiant sensitive area	A	0.045	mm^2
Abmessung der Chipfläche Dimensions of chip area	$L \times B$ $L \times W$	0.45×0.45	$\text{mm} \times \text{mm}$
Halbwinkel Half angle	φ	± 25	Grad deg.
Kapazität, $V_{\text{CE}} = 0\text{ V}$, $f = 1\text{ MHz}$, $E = 0$ Capacitance	C_{CE}	5.0	pF
Dunkelstrom Dark current $V_{\text{CE}} = 20\text{ V}$, $E = 0$	I_{CEO}	1 (≤ 50)	nA
Fotostrom Photo current $E_e = 0.1\text{ mW/cm}^2$, $V_{\text{CE}} = 5\text{ V}$	I_{PCE}	≥ 63	μA
Anstiegszeit/Abfallzeit Rise and fall time $I_{\text{C}} = 1\text{ mA}$, $V_{\text{CC}} = 5\text{ V}$, $R_{\text{L}} = 1\text{ k}\Omega$	t_r , t_f	7	μs
Kollektor-Emitter-Sättigungsspannung Collector-emitter saturation voltage $I_{\text{C}} = 20\text{ }\mu\text{A}$ $E_e = 0.1\text{ mW/cm}^2$	V_{CEsat}	150	mV

Directional Characteristics

$$S_{\text{rel}} = f(\varphi)$$

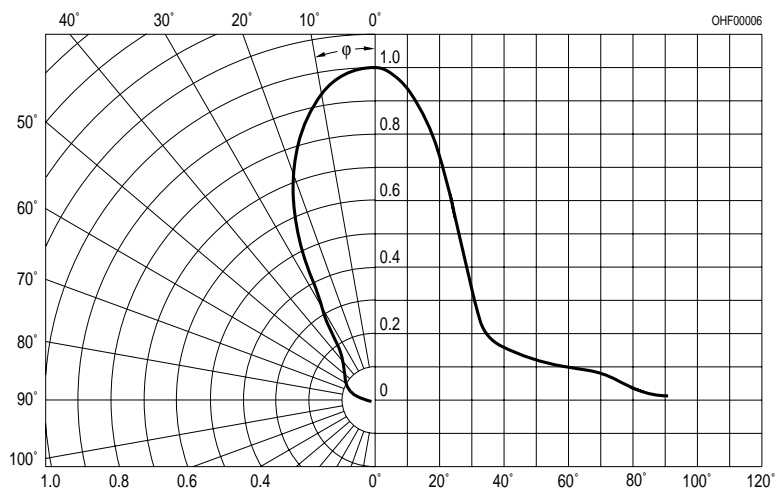

Relative Spectral Sensitivity

$S_{rel} = f(\lambda)$

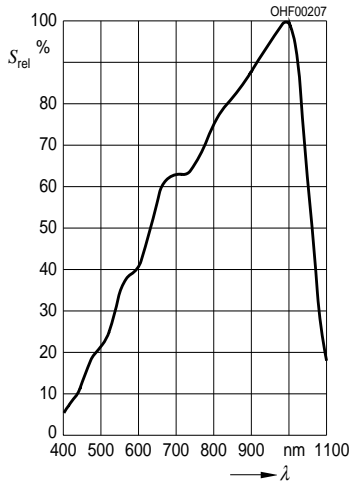

Photocurrent

$I_{PCE} = f(V_{CE}), E_e = \text{Parameter}$

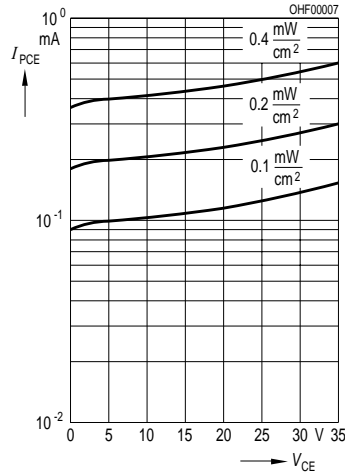

Photocurrent

$I_{PCE} / I_{PCE25^\circ} = f(T_A), V_{CE} = 5 \text{ V}$

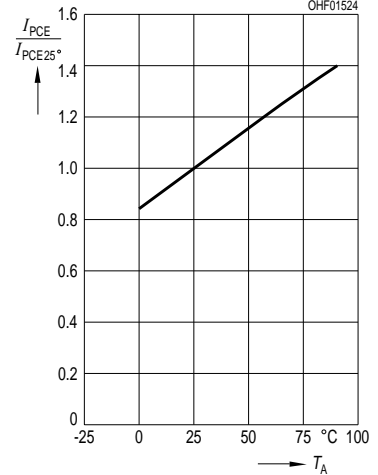

Total Power Dissipation

$P_{tot} = f(T_A)$

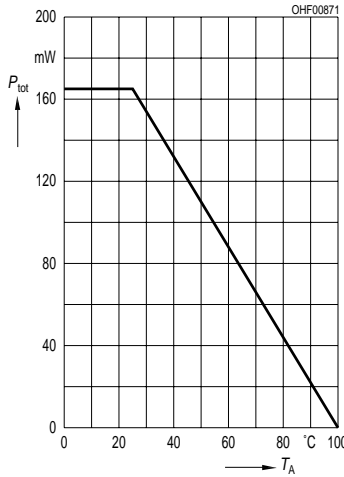

Capacitance

$C_{CE} = f(V_{CE}), f = 1 \text{ MHz}, E = 0$

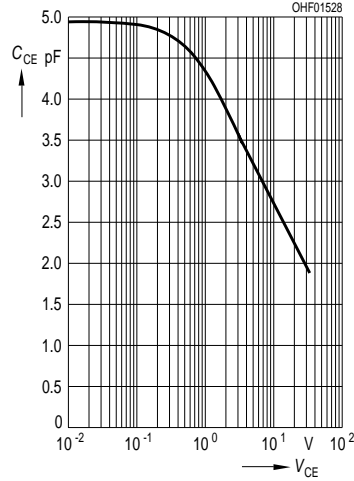

Dark Current

$I_{CEO} = f(V_{CE}), E = 0$

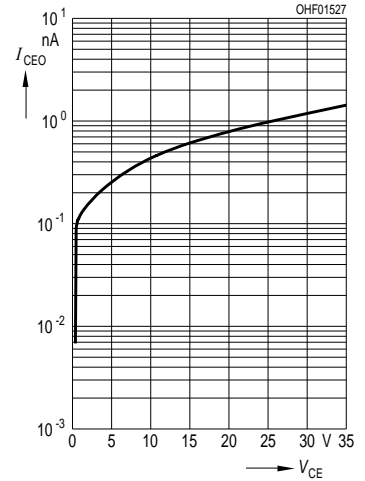

Dark Current

$I_{CEO} = f(T_A), V_{CE} = 5 \text{ V}, E = 0$

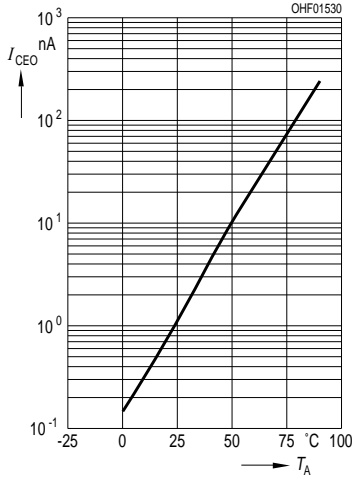

Maßzeichnung Package Outlines

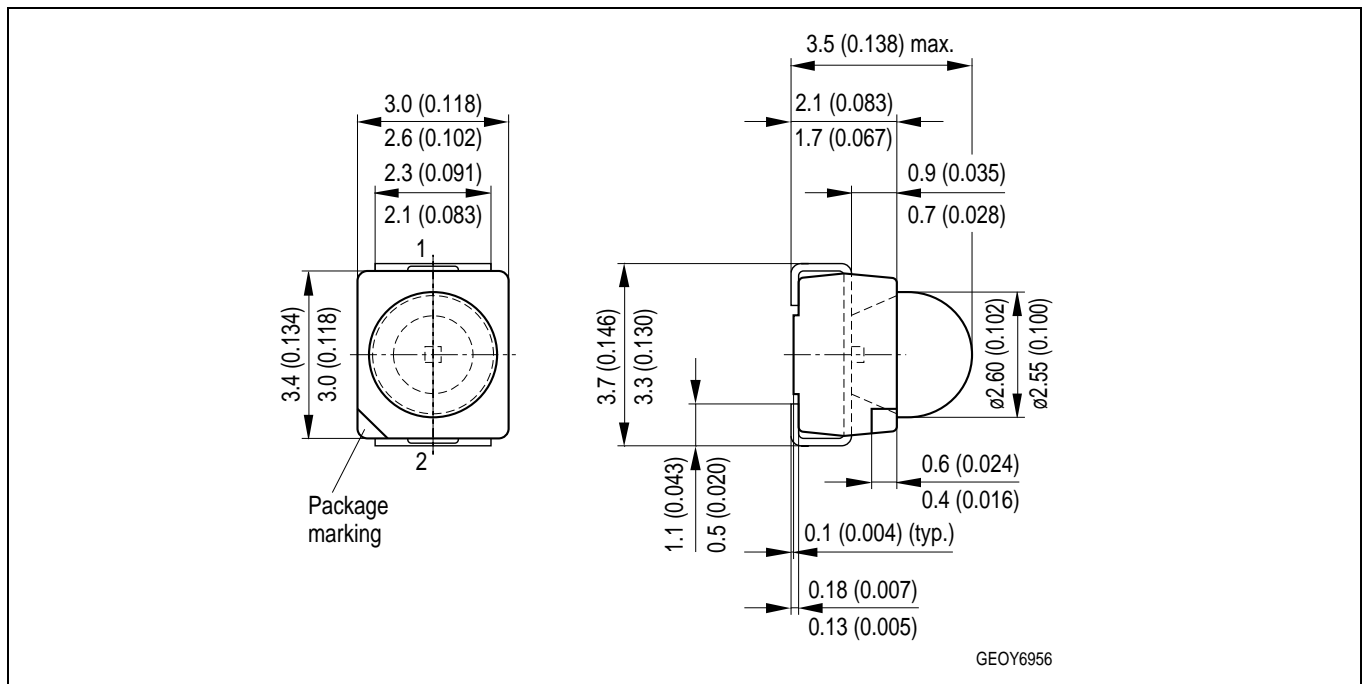

Maße werden wie folgt angegeben: mm (inch) / Dimensions are specified as follows: mm (inch).

Kathodenkennung: abgeschrägte Ecke
Cathode mark: bevelled edge

Löthinweise Soldering Conditions

Bauform Types	Tauch-, Schwall- und Schleppplötung Dip, Wave and Drag Soldering		Reflowlötung Reflow Soldering	
	Lötbad- temperatur Temperature of the Soldering Bath	Maximal zulässige Lötzeit Max. Perm. Soldering Time	Lötzonen- temperatur Temperature of Soldering Zone	Maximale Durchlaufzeit Max. Transit Time
TOPLED	260 °C	10 s	245 °C	10 s

Zusätzliche Informationen über allgemeine Lötbedingungen erhalten Sie auf Anfrage.

For additional information on general soldering conditions please contact us.

Published by OSRAM Opto Semiconductors GmbH & Co. OHG
Wernerwerkstrasse 2, D-93049 Regensburg

© All Rights Reserved.

Attention please!

The information describes the type of component and shall not be considered as assured characteristics. Terms of delivery and rights to change design reserved. Due to technical requirements components may contain dangerous substances. For information on the types in question please contact our Sales Organization.

Packing

Please use the recycling operators known to you. We can also help you – get in touch with your nearest sales office. By agreement we will take packing material back, if it is sorted. You must bear the costs of transport. For packing material that is returned to us unsorted or which we are not obliged to accept, we shall have to invoice you for any costs incurred.

Components used in life-support devices or systems must be expressly authorized for such purpose! Critical components ¹, may only be used in life-support devices or systems ² with the express written approval of OSRAM OS.

¹ A critical component is a component used in a life-support device or system whose failure can reasonably be expected to cause the failure of that life-support device or system, or to affect its safety or effectiveness of that device or system.

² Life support devices or systems are intended (a) to be implanted in the human body, or (b) to support and/or maintain and sustain human life. If they fail, it is reasonable to assume that the health of the user may be endangered.