

## 54F/74F280

### 9-Bit Parity Generator/Checker

#### General Description

The 'F280 is a high-speed parity generator/checker that accepts nine bits of input data and detects whether an even or an odd number of these inputs is HIGH. If an even number of inputs is HIGH, the Sum Even output is HIGH. If an odd number is HIGH, the Sum Even output is LOW. The Sum Odd output is the complement of the Sum Even output.

#### Features

- Guaranteed 4000V minimum ESD protection

#### Ordering Code: See Section 11

Commercial	Military	Package Number	Package Description
74F280PC		N14A	14-Lead (0.300" Wide) Molded Dual-In-Line
	54F280DM (Note 2)	J14A	14-Lead Ceramic Dual-In-Line
74F280SC (Note 1)		M14A	14-Lead (0.150" Wide) Molded Small Outline, JEDEC
74F280SJ (Note 1)		M14D	14-Lead (0.300" Wide) Molded Small Outline, EIAJ
	54F280FM (Note 2)	W14B	14-Lead Cerpack
	54F280LM (Note 2)	E20A	20-Lead Ceramic Leadless Chip Carrier, Type C

**Note 1:** Devices also available in 13" reel. Use suffix = SCX and SJX.

**Note 2:** Military grade device with environmental and burn-in processing. Use suffix = DMQB, FMQB and LMQB.

#### Logic Symbols

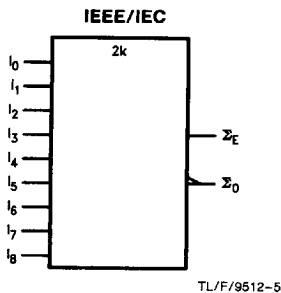
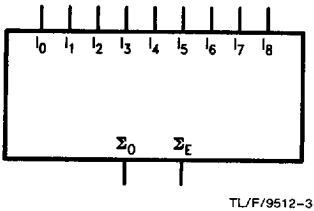

#### Connection Diagrams

Pin Assignment for  
DIP, SOIC and Flatpak

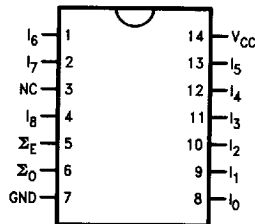

Pin Assignment  
for LCC

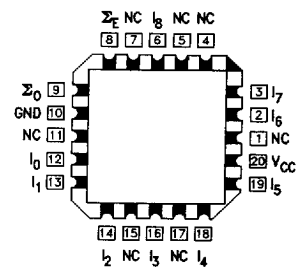

**Unit Loading/Fan Out:** See Section 2 for U.L. Definitions

查询"54F280DMQB"供应商 54F/74F			
Pin Names	Description	U.L. HIGH/LOW	Input $I_{IH}/I_{IL}$ Output $I_{OH}/I_{OL}$
$I_0-I_8$	Data Inputs	1.0/1.0	20 $\mu$ A/ -0.6 mA
$\Sigma_O$	Odd Parity Output	50/33.3	-1 mA/20 mA
$\Sigma_E$	Even Parity Output	50/33.3	-1 mA/20 mA

**Truth Table**

Number of HIGH Inputs $I_0-I_8$	Outputs	
	$\Sigma$ Even	$\Sigma$ Odd
0, 2, 4, 6, 8	H	L
1, 3, 5, 7, 9	L	H

H = HIGH Voltage Level  
L = LOW Voltage Level

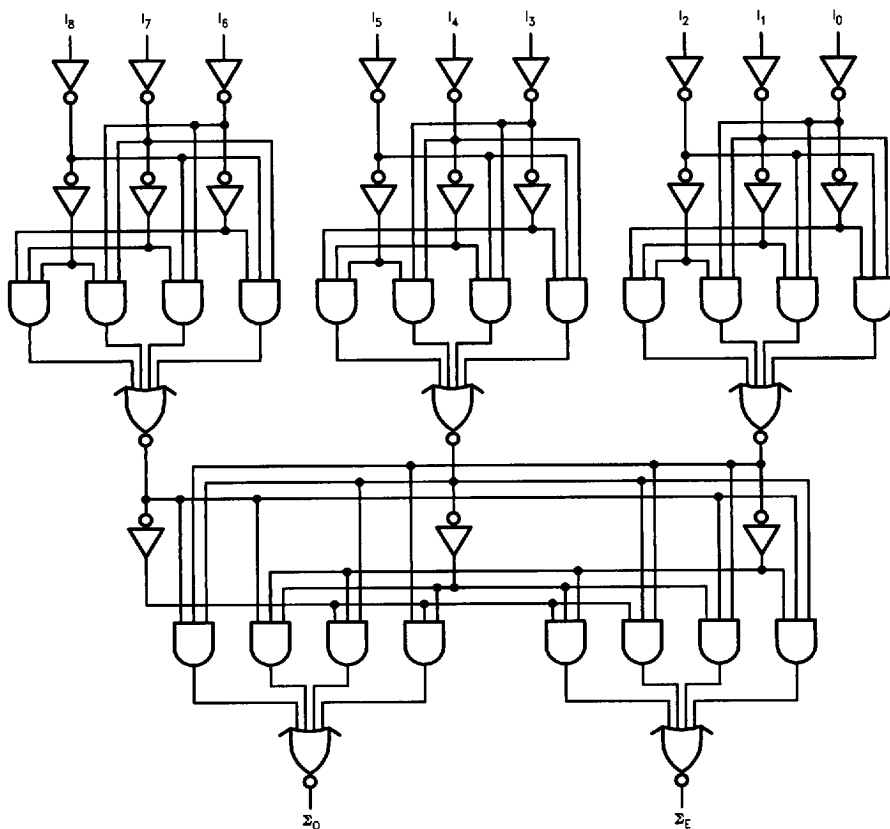
**Logic Diagram**

TL/F/9512-4

Please note that this diagram is provided only for the understanding of logic operations and should not be used to estimate propagation delays.

## Absolute Maximum Ratings (Note 1)

If Military/Aerospace specified devices are required, please contact the National Semiconductor Sales Office/Distributors for availability and specifications.

Storage Temperature	-65°C to +150°C
Ambient Temperature under Bias	-55°C to +125°C
Junction Temperature under Bias	-55°C to +175°C
Plastic	-55°C to +150°C
V <sub>CC</sub> Pin Potential to Ground Pin	-0.5V to +7.0V
Input Voltage (Note 2)	-0.5V to +7.0V
Input Current (Note 2)	-30 mA to +5.0 mA
Voltage Applied to Output in HIGH State (with V <sub>CC</sub> = 0V)	
Standard Output	-0.5V to V <sub>CC</sub>
TRI-STATE® Output	-0.5V to +5.5V
Current Applied to Output in LOW State (Max)	twice the rated I <sub>OL</sub> (mA)
ESD Last Passing Voltage (Min)	4000V

**Note 1:** Absolute maximum ratings are values beyond which the device may be damaged or have its useful life impaired. Functional operation under these conditions is not implied.

**Note 2:** Either voltage limit or current limit is sufficient to protect inputs.

## Recommended Operating Conditions

Free Air Ambient Temperature

Military	-55°C to +125°C
Commercial	0°C to +70°C

Supply Voltage

Military	+4.5V to +5.5V
Commercial	+4.5V to +5.5V

## DC Electrical Characteristics

Symbol	Parameter		54F/74F			Units	V <sub>CC</sub>	Conditions
			Min	Typ	Max			
V <sub>IH</sub>	Input HIGH Voltage		2.0			V		Recognized as a HIGH Signal
V <sub>IL</sub>	Input LOW Voltage					V		Recognized as a LOW Signal
V <sub>CD</sub>	Input Clamp Diode Voltage					V	Min	I <sub>IN</sub> = -18 mA
V <sub>OH</sub>	Output HIGH Voltage	54F 10% V <sub>CC</sub>	2.5		V	Min	I <sub>OH</sub> = -1 mA	
		74F 10% V <sub>CC</sub>	2.5					
		74F 5% V <sub>CC</sub>	2.7					
V <sub>OL</sub>	Output LOW Voltage	54F 10% V <sub>CC</sub>	0.5		V	Min	I <sub>OL</sub> = 20 mA	
		74F 10% V <sub>CC</sub>	0.5					
I <sub>IH</sub>	Input HIGH Current	54F	20.0		μA	Max	V <sub>IN</sub> = 2.7V	
		74F	5.0					
I <sub>BV1</sub>	Input HIGH Current Breakdown Test	54F	100		μA	Max	V <sub>IN</sub> = 7.0V	
		74F	7.0					
I <sub>CEX</sub>	Output HIGH Leakage Current	54F	250		μA	Max	V <sub>OUT</sub> = V <sub>CC</sub>	
		74F	50					
V <sub>ID</sub>	Input Leakage Test	74F	4.75		V	0.0	I <sub>ID</sub> = 1.9 μA All Other Pins Grounded	
I <sub>OD</sub>	Output Leakage Circuit Current	74F	3.75		μA	0.0	V <sub>IOD</sub> = 150 mV All Other Pins Grounded	
I <sub>IL</sub>	Input LOW Current		-0.6		mA	Max	V <sub>IN</sub> = 0.5V	
I <sub>OS</sub>	Output Short-Circuit Current		-60	-150	mA	Max	V <sub>OUT</sub> = 0V	
I <sub>CCH</sub>	Power Supply Current		25	38	mA	Max	V <sub>O</sub> = HIGH	

**AC Electrical Characteristics:** See Section 2 for Waveforms and Load Configurations

[查询"54F280DMQB"供应商](#)

Symbol	Parameter	74F			54F		74F		Units	Fig. No.
		$T_A = +25^\circ\text{C}$			$T_A, V_{CC} = \text{Mil}$		$T_A, V_{CC} = \text{Com}$			
		$V_{CC} = +5.0\text{V}$ $C_L = 50\text{ pF}$			$C_L = 50\text{ pF}$		$C_L = 50\text{ pF}$			
Min	Typ	Max	Min	Max	Min	Max				
$t_{PLH}$	Propagation Delay	6.5	10.0	15.0	6.5	20.0	6.5	16.0	ns	2-3
$t_{PHL}$	$I_n$ to $\Sigma_E$	6.5	11.0	16.0	6.5	21.0	6.5	17.0		
$t_{PLH}$	Propagation Delay	6.0	10.0	15.0	5.0	20.0	6.0	16.0	ns	2-3
$t_{PHL}$	$I_n$ to $\Sigma_O$	6.5	11.0	16.0	6.5	21.0	6.5	17.0		