

# UTC RXXLD20 LINEAR INTEGRATED CIRCUIT

## 2.0A Output Type Low Power-Loss Voltage Regulator

### FEATURES

- \*Low power-loss(Dropout voltage: 0.5V(max) at  $I_o=2.0A$ )
- \*2.0A output type
- \* Output voltage precision:  $\pm 3.0\%$
- \*Built-in ON/OFF control function
- \*Built in over current, overheat protection function, ASO protection circuit.
- \*Lead forming type is also available.

### APPLICATIONS

- \*Power supplies for various electronic equipment such as AV,OA equipment.

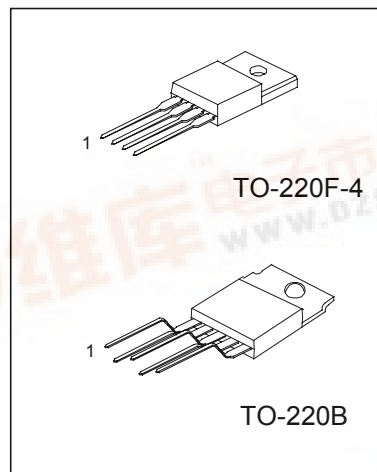

### INTERNAL CONNECTION DIAGRAM

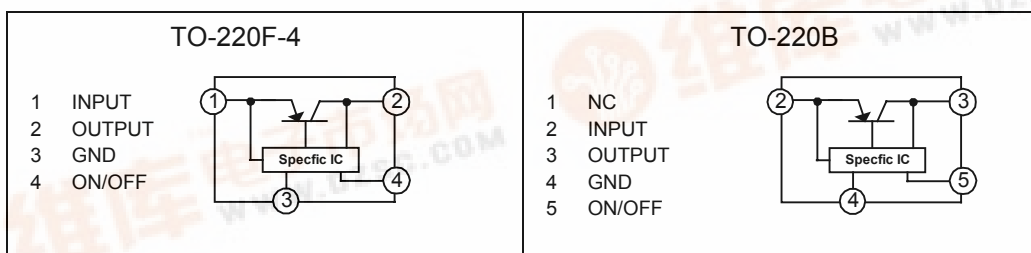

### Model Line-ups

	2.0A output
3.3V output	R33LD20
5.0V output	R05LD20
9.0V output	R09LD20
12.0V output	R12LD20

### ABSOLUTE MAXIMUM RATINGS (Ta=25°C)

PARAMETER	SYMBOL	RATING	UNIT
Input voltage <sup>(note 1)</sup>	$V_{IN}$	20	V
ON/OFF control terminal voltage <sup>(note1)</sup>	$V_C$	20	V
Output current	$I_o$	2.0	A
Power dissipation <sup>(note2)</sup>	$P_{D1}$	1.4	W
	$P_{D2}$	15	W
Junction temperature <sup>(note3)</sup>	$T_j$	150	°C
Operating temperature	$T_{opr}$	-20 ~ +80	°C
Storage temperature	$T_{sta}$	-40 ~ +150	°C
Soldering temperature	$T_{sol}$	260(For 10s)	°C

note1 : All are open except GND and applicable terminals.

## UTC RXXLD20 LINEAR INTEGRATED CIRCUIT

note2 : P<sub>D1</sub>:No heat sink; P<sub>D2</sub>:With infinite heat sink

note3 : Overheat protection may operate at 125 ≤ T<sub>j</sub> ≤ 150°C

### UTC R33LD20 ELECTRICAL CHARACTERISTICS

(refer to the test circuits, unless otherwise specified, T<sub>a</sub>=25°C)

PARAMETER	SYMBOL	TEST CONDITIONS	MIN	TYP	MAX	UNIT
Output voltage	V <sub>o</sub>	V <sub>in</sub> =5V, I <sub>o</sub> =1A	3.201	3.3	3.399	V
Line regulation	ΔV <sub>o</sub>	V <sub>in</sub> =4~10V, I <sub>o</sub> =5mA		0.1	2.5	%
Load regulation	ΔV <sub>o</sub>	V <sub>in</sub> =5V, I <sub>o</sub> =5mA ~2.0A		0.1	2.0	%
Temperature coefficient of output voltage	T <sub>c</sub> V <sub>o</sub>	T <sub>j</sub> =0~125°C, I <sub>o</sub> =5mA		±0.02		%/°C
Ripple rejection	RR	Refer to Fig.2	45	55		dB
Dropout voltage	V <sub>d</sub>	(note4), I <sub>o</sub> =2A			0.5	V
ON-state voltage for control (note5)	V <sub>C(ON)</sub>	V <sub>in</sub> =5V	2.0			V
ON-state current for control	I <sub>C(ON)</sub>	V <sub>c</sub> =2.7V, V <sub>in</sub> =5V			20	μA
OFF-state voltage for control	V <sub>C(OFF)</sub>	V <sub>in</sub> =5V			0.8	V
OFF-state current for control	I <sub>C(OFF)</sub>	V <sub>c</sub> =0.4V, V <sub>in</sub> =5V			-0.4	mA
Quiescent current	I <sub>q</sub>	I <sub>o</sub> =0A, V <sub>in</sub> =5V			10	mA

### UTC R05LD20 ELECTRICAL CHARACTERISTICS

(refer to the test circuits, unless otherwise specified, T<sub>a</sub>=25°C)

PARAMETER	SYMBOL	TEST CONDITIONS	MIN	TYP	MAX	UNIT
Output voltage	V <sub>o</sub>	V <sub>in</sub> =7V, I <sub>o</sub> =1A	4.85	5.0	5.15	V
Line regulation	ΔV <sub>o</sub>	V <sub>in</sub> =6~12V, I <sub>o</sub> =5mA		0.5	2.5	%
Load regulation	ΔV <sub>o</sub>	V <sub>in</sub> =7V, I <sub>o</sub> =5mA ~2.0A		0.1	2.0	%
Temperature coefficient of output voltage	T <sub>c</sub> V <sub>o</sub>	T <sub>j</sub> =0~125°C, I <sub>o</sub> =5mA		±0.02		%/°C
Ripple rejection	RR	Refer to Fig.2	45	55		dB
Dropout voltage	V <sub>d</sub>	(note4), I <sub>o</sub> =2A			0.5	V
ON-state voltage for control (note5)	V <sub>C(ON)</sub>	V <sub>in</sub> =7V	2.0			V
ON-state current for control	I <sub>C(ON)</sub>	V <sub>c</sub> =2.7V, V <sub>in</sub> =7V			20	μA
OFF-state voltage for control	V <sub>C(OFF)</sub>	V <sub>in</sub> =7V			0.8	V
OFF-state current for control	I <sub>C(OFF)</sub>	V <sub>c</sub> =0.4V, V <sub>in</sub> =7V			-0.4	mA
Quiescent current	I <sub>q</sub>	I <sub>o</sub> =0A, V <sub>in</sub> =7V			10	mA

## UTC RXXLD20 LINEAR INTEGRATED CIRCUIT

### UTC R09LD20 ELECTRICAL CHARACTERISTICS

(refer to the test circuits, unless otherwise specified, Ta=25°C)

PARAMETER	SYMBOL	TEST CONDITIONS	MIN	TYP	MAX	UNIT
Output voltage	V <sub>o</sub>	V <sub>in</sub> =11V, I <sub>o</sub> =1A	8.73	9.0	9.27	V
Line regulation	ΔV <sub>o</sub>	V <sub>in</sub> =10~16V, I <sub>o</sub> =5mA		0.5	2.5	%
Load regulation	ΔV <sub>o</sub>	V <sub>in</sub> =11V, I <sub>o</sub> =5mA ~2.0A		0.1	2.0	%
Temperature coefficient of output voltage	TcV <sub>o</sub>	T <sub>j</sub> =0~125°C, I <sub>o</sub> =5mA		±0.02		%/°C
Ripple rejection	RR	Refer to Fig.2	45	55		dB
Dropout voltage	V <sub>d</sub>	(note4), I <sub>o</sub> =2A			0.5	V
ON-state voltage for control <sup>(note5)</sup>	V <sub>C(ON)</sub>	V <sub>in</sub> =11V	2.0			V
ON-state current for control	I <sub>C(ON)</sub>	V <sub>c</sub> =2.7V, V <sub>in</sub> =11V			20	μA
OFF-state voltage for control	V <sub>C(OFF)</sub>	V <sub>in</sub> =11V			0.8	V
OFF-state current for control	I <sub>C(OFF)</sub>	V <sub>c</sub> =0.4V, V <sub>in</sub> =11V			-0.4	mA
Quiescent current	I <sub>q</sub>	I <sub>o</sub> =0A, V <sub>in</sub> =11V			10	mA

### UTC R12LD20 ELECTRICAL CHARACTERISTICS

(refer to the test circuits, unless otherwise specified, Ta=25°C)

PARAMETER	SYMBOL	TEST CONDITIONS	MIN	TYP	MAX	UNIT
Output voltage	V <sub>o</sub>	V <sub>in</sub> =14V, I <sub>o</sub> =1A	11.64	12.0	12.36	V
Line regulation	ΔV <sub>o</sub>	V <sub>in</sub> =13~19V, I <sub>o</sub> =5mA		0.5	2.5	%
Load regulation	ΔV <sub>o</sub>	V <sub>in</sub> =14V, I <sub>o</sub> =5mA ~2.0A		0.1	2.0	%
Temperature coefficient of output voltage	TcV <sub>o</sub>	T <sub>j</sub> =0~125°C, I <sub>o</sub> =5mA		±0.02		%/°C
Ripple rejection	RR	Refer to Fig.2	45	55		dB
Dropout voltage	V <sub>d</sub>	(note4), I <sub>o</sub> =2A			0.5	V
ON-state voltage for control <sup>(note5)</sup>	V <sub>C(ON)</sub>	V <sub>in</sub> =14V	2.0			V
ON-state current for control	I <sub>C(ON)</sub>	V <sub>c</sub> =2.7V, V <sub>in</sub> =14V			20	μA
OFF-state voltage for control	V <sub>C(OFF)</sub>	V <sub>in</sub> =14V			0.8	V
OFF-state current for control	I <sub>C(OFF)</sub>	V <sub>c</sub> =0.4V, V <sub>in</sub> =14V			-0.4	mA
Quiescent current	I <sub>q</sub>	I <sub>o</sub> =0A, V <sub>in</sub> =14V			10	mA

note4 : Input voltage shall be the value when output voltage is 95% in comparison with the initial value.

note5 : TO-220B: In case of opening control terminal ⑤, output voltage turns on.

TO-220F-4: In case of opening control terminal ④, output voltage turns on.

# UTC RXXLD20 LINEAR INTEGRATED CIRCUIT

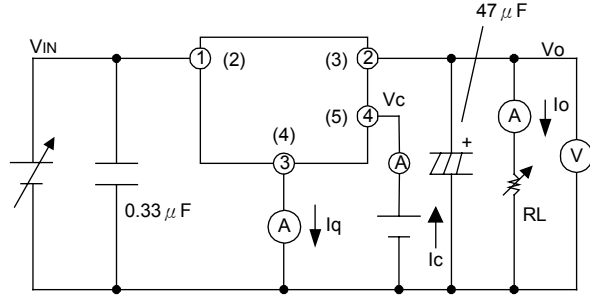

( ) : TO-220B

Fig.1 Test Circuit

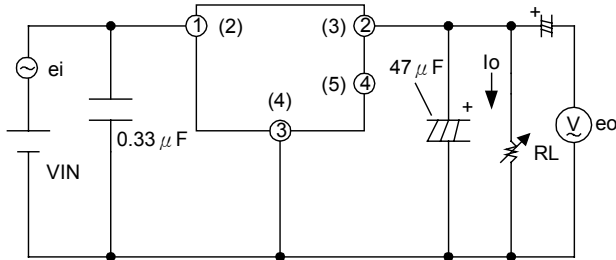

( ) : TO-220B

VIN=5V(R33LD20) f=120Hz  
 7V(R05LD20) ei=0.5Vrms  
 11V(R09LD20) Io=0.5A  
 14V(R12LD20) RR=20log(ei/eo)

Fig.2 Test Circuit of Ripple Rejection

Fig.3 Power Dissipation vs. Ambient Temperature

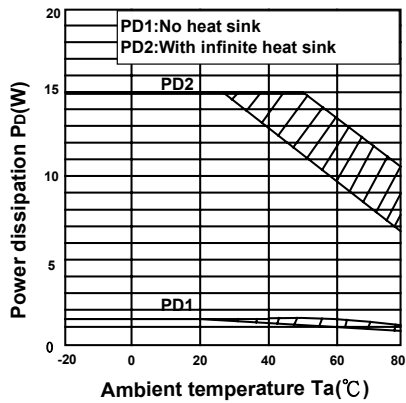

Note) Oblique line portion:Overheat protection may operate in this area.

Fig.4 Overcurrent Protection Characteristics(Typical Value) (R33LD20)

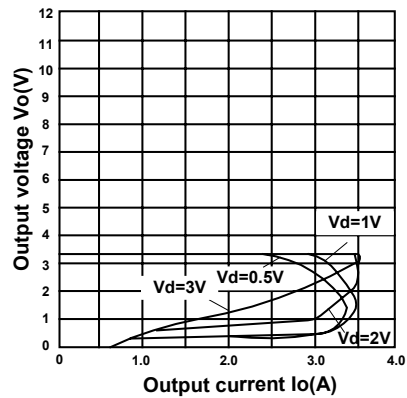

# UTC RXXLD20 LINEAR INTEGRATED CIRCUIT

**Fig.5 Overcurrent Protection Characteristics (Typical Value)(R05LD20)**

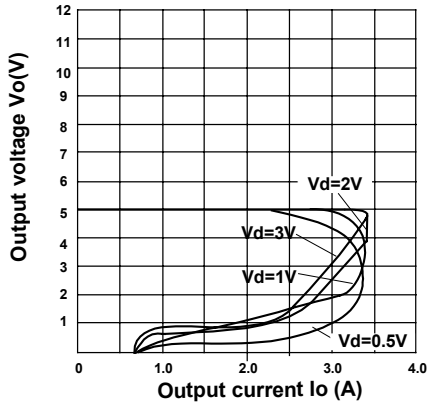

**Fig.6 Overcurrent Protection Characteristics (Typical Value)(R09LD20)**

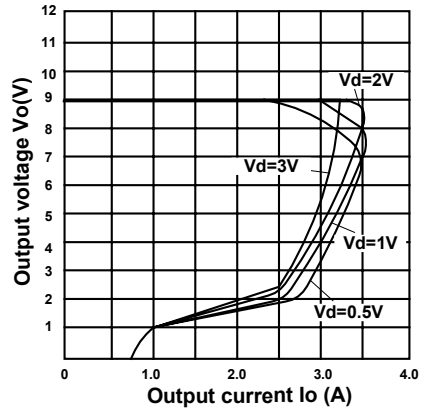

**Fig.7 Overcurrent Protection Characteristics (Typical Value)(R12LD20)**

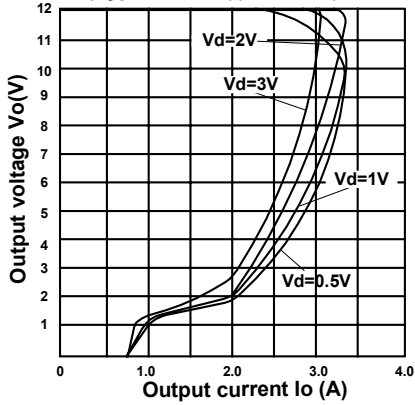

**Fig.8 Output Voltage Deviation vs .Junction Temperature (R03LD20)**

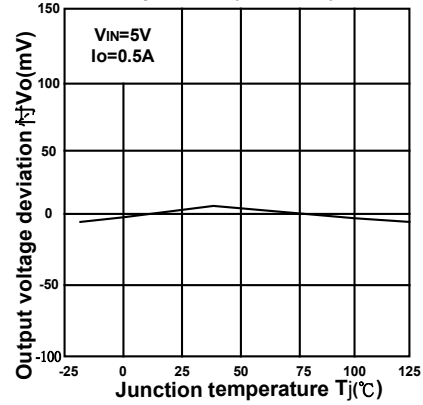

**Fig.9 Output Voltage Deviation vs .Junction Temperature (R05LD20)**

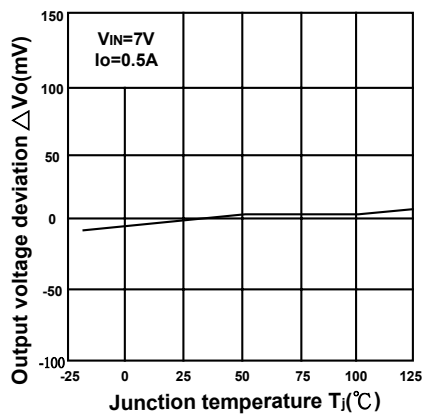

**Fig.10 Output Voltage Deviation vs .Junction Temperature (R09LD20)**

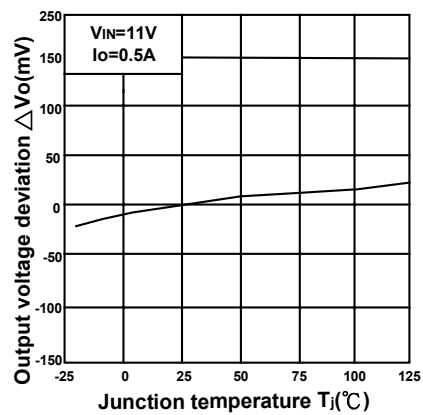

# UTC RXXLD20 LINEAR INTEGRATED CIRCUIT

Fig.11 Output Voltage Deviation vs .Junction Temperature (R12LD20)

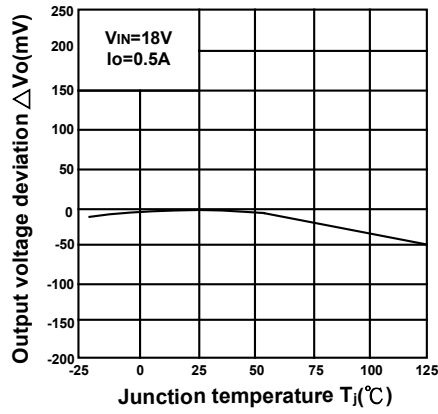

Fig.12 Output Voltage vs .Input Voltage (R33LD20)

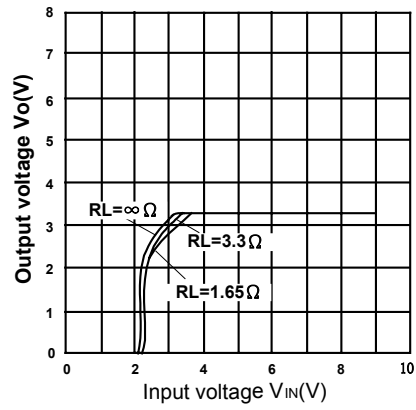

Fig.13 Output Voltage vs .Input Voltage (R05LD20)

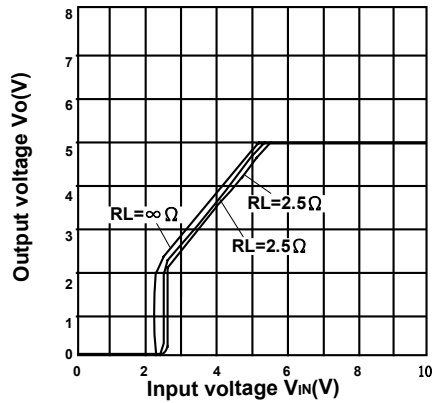

Fig.14 Output Voltage vs .Input Voltage (R09LD20)

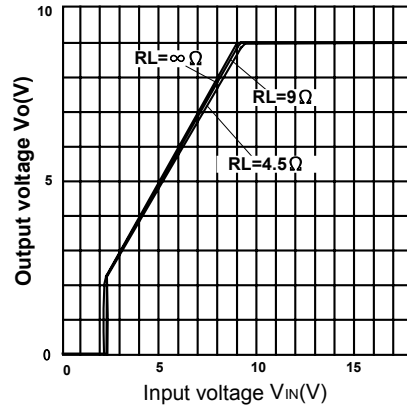

Fig.15 Output Voltage vs .Input Voltage (R12LD20)

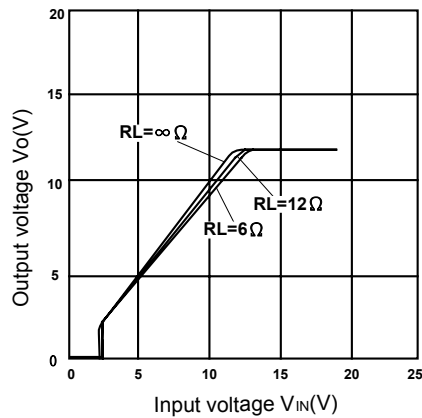
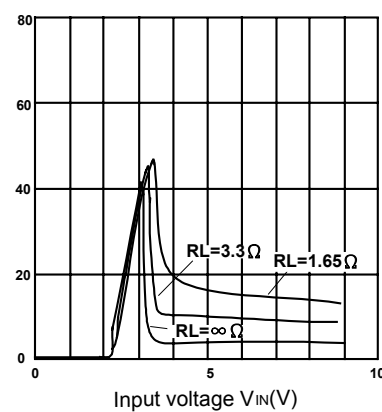

Fig.16 Circuit Operating Current vs .Input Voltage (R33LD20)



# UTC RXXLD20 LINEAR INTEGRATED CIRCUIT

Fig.17 Circuit Operating Current vs .Input Voltage (R05LD20)

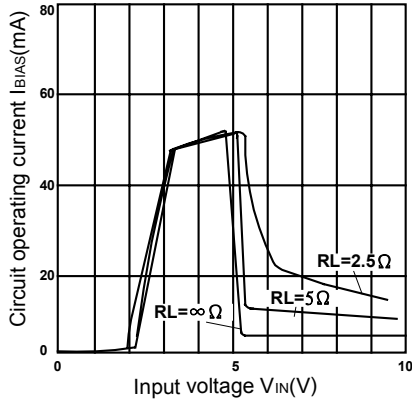

Fig.18 Circuit Operating Current vs .Input Voltage (R09LD20)

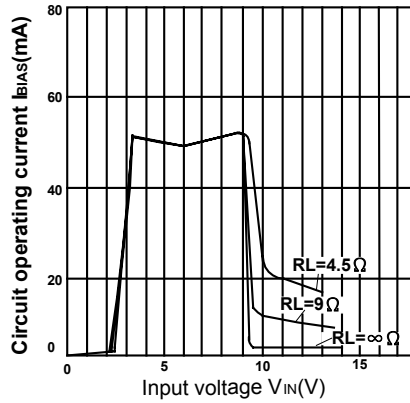

Fig.19 Circuit Operating Current vs .Input Voltage (R12LD20)

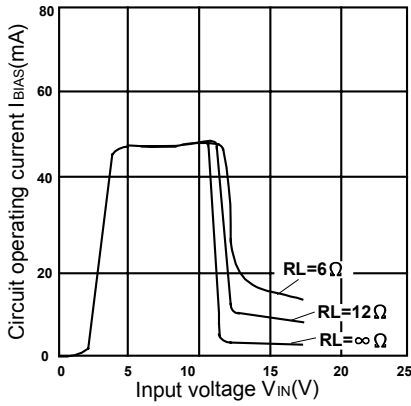

Fig.20 Dropout Voltage vs .Junction Temperature

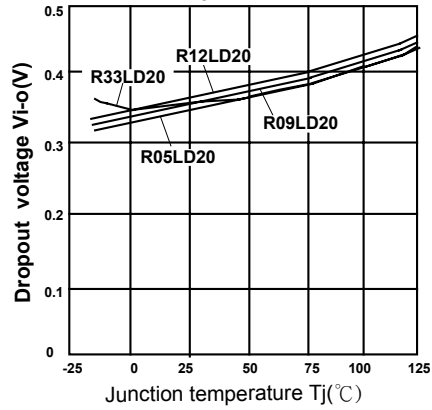

Fig.21 Quiescent Current vs .Junction Temperature

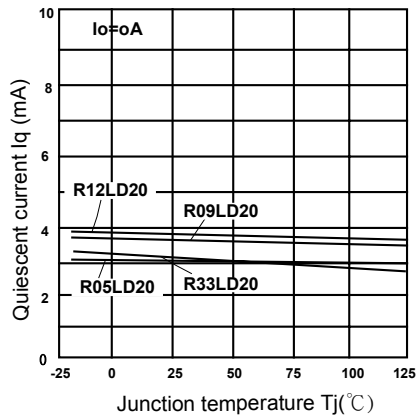
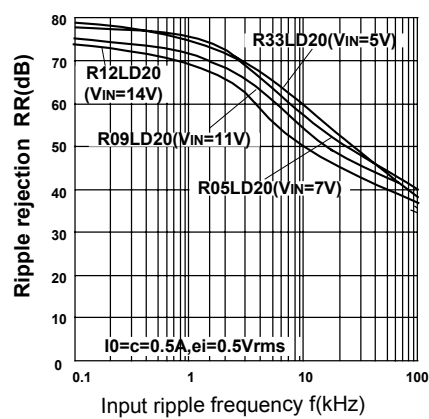

Fig.22 Ripple Rejection vs .Input Ripple Frequency



# UTC RXXLD20 LINEAR INTEGRATED CIRCUIT

## TYPICAL APPLICATION

