

[查询"BGF106C"供应商](#)

BGF106C

SIM Card Interface Filter and ESD Protection

Small Signal Discretes



Never stop thinking

Edition 2009-04-14

**Published by
Infineon Technologies AG
81726 München, Germany**

**© Infineon Technologies AG 2009.
All Rights Reserved.**

Legal Disclaimer

The information given in this document shall in no event be regarded as a guarantee of conditions or characteristics ("Beschaffenhheitsgarantie"). With respect to any examples or hints given herein, any typical values stated herein and/or any information regarding the application of the device, Infineon Technologies hereby disclaims any and all warranties and liabilities of any kind, including without limitation warranties of non-infringement of intellectual property rights of any third party.

Information

For further information on technology, delivery terms and conditions and prices please contact your nearest Infineon Technologies Office (www.infineon.com).

Warnings

Due to technical requirements components may contain dangerous substances. For information on the types in question please contact your nearest Infineon Technologies Office.

Infineon Technologies Components may only be used in life-support devices or systems with the express written approval of Infineon Technologies, if a failure of such components can reasonably be expected to cause the failure of that life-support device or system, or to affect the safety or effectiveness of that device or system. Life support devices or systems are intended to be implanted in the human body, or to support and/or maintain and sustain and/or protect human life. If they fail, it is reasonable to assume that the health of the user or other persons may be endangered.

BGF106C

Revision History: 2009-04-14, V2.0

Previous Version: 2009-03-31, V1.0

Page	Subjects (major changes since last revision)
all	target status removed
5	Table 1: maximum voltage on all pins increased to 5.5 V

BGF106C

Features

- ESD protection circuit and interface filter for SIM cards
- ESD protection according to IEC61000-4-2 for ± 15 kV contact discharge on external IOs
- Wafer level package with SnAgCu solder balls
- 400 μm solder ball pitch
- RoHS and WEEE compliant package

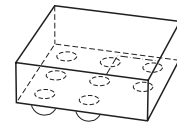

WLP-8-11-N-3D



Description

BGF106C is an ESD protection circuit and filtering interface for SIM cards. All external IOs are protected against ESD pulses of ± 15 kV contact discharge according to IEC61000-4-2. The wafer level package is a green lead-free and halogen-free package with a size of only 1.2 mm x 1.2 mm and a total height of 0.6 mm

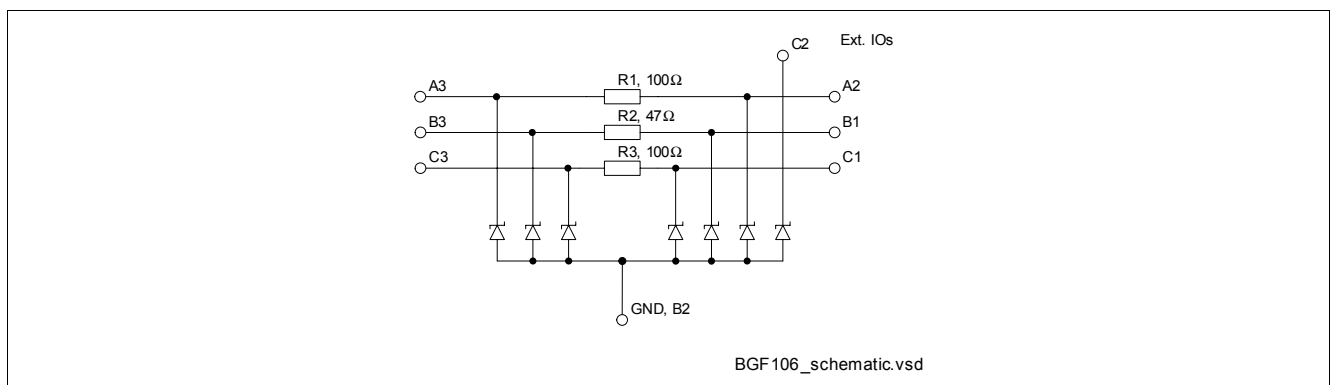

Figure 1 Schematic

Type	Package	Marking	Chip
BGF106C	WLP-8-11	6C	N0727

Table 1 Maximum Ratings

Parameter	Symbol	Values			Unit	Note / Test Condition
		Min.	Typ.	Max.		
Voltage at all pins to GND	V_P	0	–	5.5	V	–
Operating temperature range	T_{OP}	-40	–	+85	°C	–
Storage temperature range	T_{STG}	-65	–	+150	°C	–
Summed up input power for all pins	P_{in}	–	–	60	mW	$T_S < 70\text{ °C}$
Electrostatic discharge according to IEC61000-4-2						
Contact discharge at internal pins A3, B3, C3 to any other pin	V_{ESD}	-2	–	2	kV	–
Contact discharge at external pins A2, B1, C1, C2 to GND	V_{ESD}	-15	–	15	kV	–

Table 2 Electrical Characteristics¹⁾

Parameter	Symbol	Values			Unit	Note / Test Condition
		Min.	Typ.	Max.		
Resistors R_1, R_3	$R_{1,3}$	80	100	120	Ω	–
Resistor R_2	R_2	37.6	47	56.4	Ω	–
Reverse current of ESD protection diodes	I_R	–	1	100	nA	$V = 3\text{ V}$
		–	2	1000	nA	$V = 5\text{ V}$
Breakdown voltage of ESD diodes	$V_{(BR)}$	6.5	7.8	–	V	$I_{(BR)} = 1\text{ mA}$
Line capacitance Capacitance of all lines to GND	C_T	–	16.5	20	pF	$V = 0\text{ V}$

1) at $T_A = 25\text{ °C}$

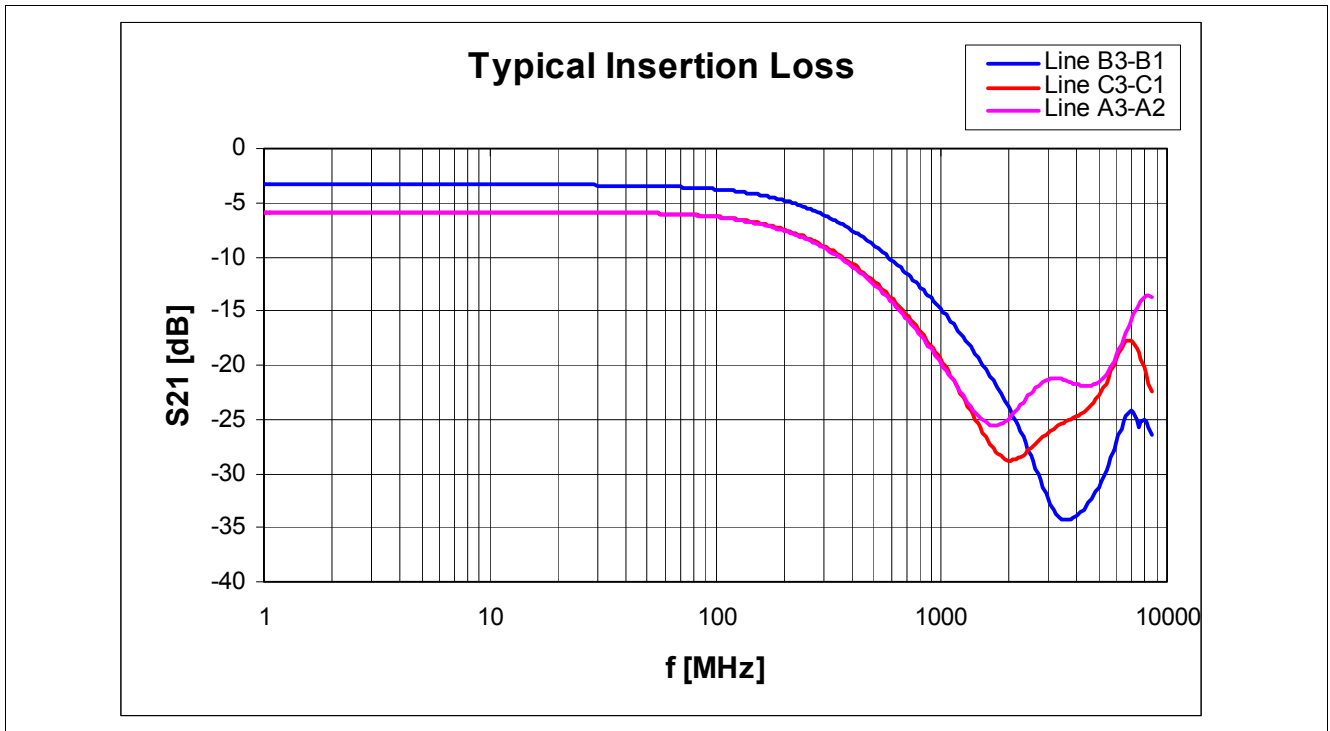

Figure 2 Insertion loss, $Z_S=Z_L=50 \Omega$

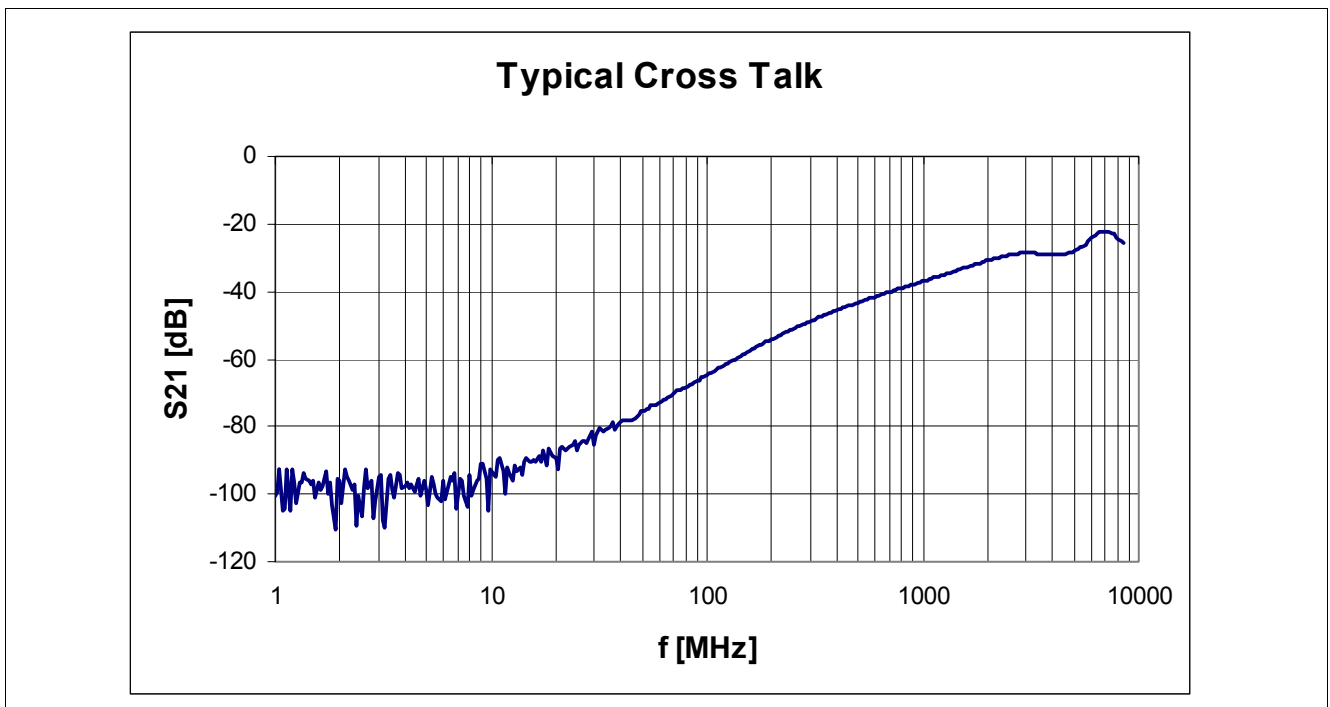

Figure 3 Cross talk, $Z_S=Z_L=50 \Omega$ (all unused input and output pins are terminated with 50Ω)

Package Outlines

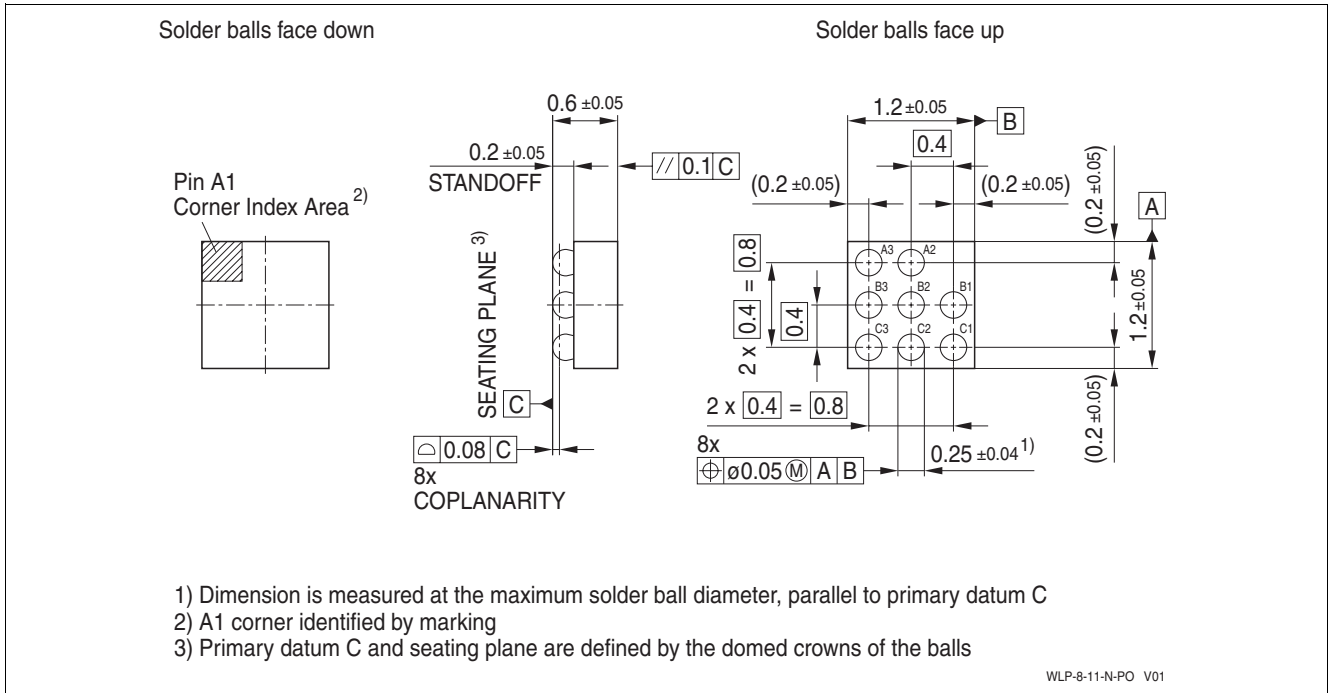

Figure 4 WLP-8-11 (Wafer Level Package)

Footprint

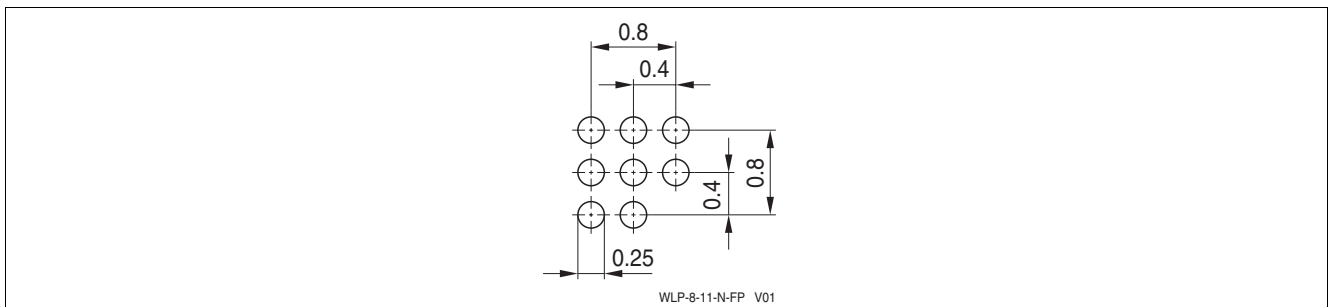

Figure 5 Recommended PCB pad design for reflow soldering

Tape

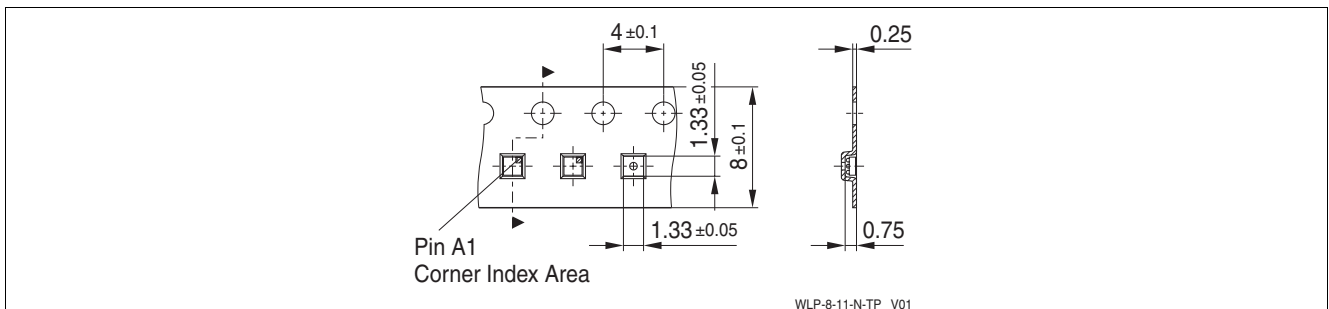

Figure 6 Tape for BGF106C / WLP-8-11

You can find all of our packages, sorts of packing and others in our Infineon Internet Page "Products":
<http://www.infineon.com/products>.