

REVISIONS

LTR	DESCRIPTION	DATE (YR-MO-DA)	APPROVED
<a href="#">查询5962R9575401VEC*供应商</a>			

REV																				
SHEET																				
REV																				
SHEET	15																			

REV STATUS OF SHEETS	REV																			
	SHEET	1	2	3	4	5	6	7	8	9	10	11	12	13	14					

<p>PMIC N/A</p> <p><b>STANDARD MICROCIRCUIT DRAWING</b></p> <p>THIS DRAWING IS AVAILABLE FOR USE BY ALL DEPARTMENTS AND AGENCIES OF THE DEPARTMENT OF DEFENSE</p> <p>AMSC N/A</p>	<p>PREPARED BY Joseph A. Kerby</p>	<p><b>DEFENSE ELECTRONICS SUPPLY CENTER DAYTON, OHIO 45444</b></p>		
	<p>CHECKED BY Thanh V. Nguyen</p>			
	<p>APPROVED BY Monica L. Poelking</p>			
	<p>DRAWING APPROVAL DATE 95-11-03</p>	<p>SIZE <b>A</b></p>	<p>CAGE CODE <b>67268</b></p>	<p><b>5962-95754</b></p>
	<p>REVISION LEVEL</p>	<p>SHEET 1 OF 15</p>		

DESC FORM 193  
JUL 94

DISTRIBUTION STATEMENT A. Approved for public release; distribution is unlimited.

5962-E327-95

9004708 0015493 500

1. SCOPE

1.1 Scope. This drawing forms a part of a one part - one part number documentation system (see 6.6 herein). Two product assurance classes consisting of military high reliability (device classes Q and M) and space application (device class V), and a choice of case outlines and lead finishes are available and are reflected in the Part or Identifying Number (PIN). Device class M microcircuits represent non-JAN class B microcircuits in accordance with 1.2.1 of MIL-STD-883, "Provisions for the use of MIL-STD-883 in conjunction with compliant non-JAN devices". When available, a choice of Radiation Hardness Assurance (RHA) levels are reflected in the PIN.

1.2 PIN. The PIN shall be as shown in the following example:

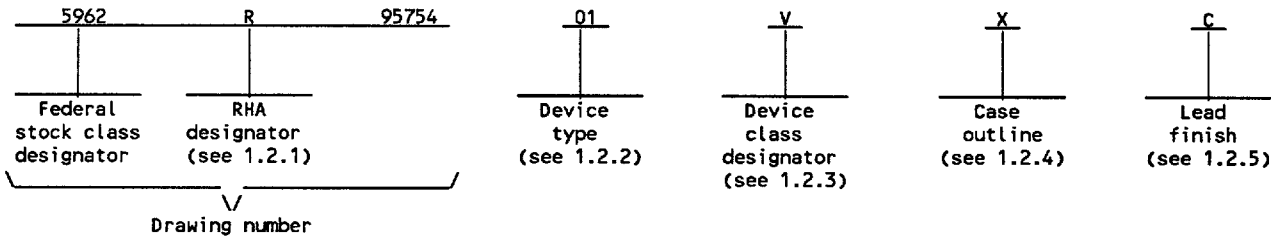

1.2.1 RHA designator. Device class M RHA marked devices shall meet the MIL-I-38535 appendix A specified RHA levels and shall be marked with the appropriate RHA designator. Device classes Q and V RHA marked devices shall meet the MIL-I-38535 specified RHA levels and shall be marked with the appropriate RHA designator. A dash (-) indicates a non-RHA device.

1.2.2 Device type(s). The device type(s) shall identify the circuit function as follows:

<u>Device type</u>	<u>Generic number</u>	<u>Circuit function</u>
01	HCTS153	Radiation hardened, SOS, high speed CMOS, dual 4-input multiplexer, TTL compatible inputs

1.2.3 Device class designator. The device class designator shall be a single letter identifying the product assurance level as follows:

<u>Device class</u>	<u>Device requirements documentation</u>
M	Vendor self-certification to the requirements for non-JAN class B microcircuits in accordance with 1.2.1 of MIL-STD-883
Q or V	Certification and qualification to MIL-I-38535

1.2.4 Case outline(s). The case outline(s) shall be as designated in MIL-STD-1835 and as follows:

<u>Outline letter</u>	<u>Descriptive designator</u>	<u>Terminals</u>	<u>Package style</u>
E	CDIP2-T16	16	Dual-in-line
X	CDFP4-F16	16	Flat pack

1.2.5 Lead finish. The lead finish shall be as specified in MIL-STD-883 (see 3.1 herein) for class M or MIL-I-38535 for classes Q and V. Finish letter "X" shall not be marked on the microcircuit or its packaging. The "X" designation is for use in specifications when lead finishes A, B, and C are considered acceptable and interchangeable without preference.

<b>STANDARD MICROCIRCUIT DRAWING DEFENSE ELECTRONICS SUPPLY CENTER DAYTON, OHIO 45444</b>	<b>SIZE A</b>	<b>5962-95754</b>
	<b>REVISION LEVEL</b>	<b>SHEET 2</b>

1.3 Absolute maximum ratings. 1/ 2/ 3/

Supply voltage range ( $V_{CC}$ )	-0.5 V dc to +7.0 V dc
Input voltage range ( $V_{IN}$ )	-0.5 V dc to $V_{CC} + 0.5$ V dc
DC output voltage range ( $V_{OUT}$ )	-0.5 V dc to $V_{CC} + 0.5$ V dc
DC input current, any one input ( $I_{IN}$ )	$\pm 10$ mA
DC output current, any one output ( $I_{OUT}$ )	$\pm 25$ mA
Storage temperature range ( $T_{STG}$ )	-65°C to +150°C
Lead temperature (soldering, 10 seconds)	+265°C
Thermal resistance, junction-to-case ( $\theta_{JC}$ ):	
Case outline E	24°C/W
Case outline X	29°C/W
Thermal resistance, junction-to-ambient ( $\theta_{JA}$ ):	
Case outline E	73°C/W
Case outline X	114°C/W
Junction temperature ( $T_J$ )	+175°C
Maximum package power dissipation at $T_A = +125^\circ\text{C}$ ( $P_D$ ): 4/	
Case outline E	0.68 W
Case outline X	0.44 W

1.4 Recommended operating conditions. 2/ 3/

Supply voltage range ( $V_{CC}$ )	+4.5 V dc to +5.5 V dc
Input voltage range ( $V_{IN}$ )	+0.0 V dc to $V_{CC}$
Output voltage range ( $V_{OUT}$ )	+0.0 V dc to $V_{CC}$
Maximum low level input voltage ( $V_{IL}$ )	0.8 V
Minimum high level input voltage ( $V_{IH}$ )	$V_{CC}/2$
Case operating temperature range ( $T_C$ )	-55°C to +125°C
Maximum input rise and fall time at $V_{CC} = 4.5$ V ( $t_r, t_f$ )	500 ns
Radiation features:	
Total dose	> $2 \times 10^5$ Rads (Si)
Single event phenomenon (SEP) effective	
Linear energy threshold (LET) No upsets (see 4.4.4.4)	> 100 MeV/(cm <sup>2</sup> /mg) 5/
Dose rate upset (20 ns pulse)	> $1 \times 10^{10}$ Rads (Si)/s 5/
Latch-up	None 5/
Dose rate survivability	> $1 \times 10^{12}$ Rads (Si)/s 5/

2. APPLICABLE DOCUMENTS

2.1 Government specification, standards, bulletin, and handbook. Unless otherwise specified, the following specification, standards, bulletin, and handbook of the issue listed in that issue of the Department of Defense Index of Specifications and Standards specified in the solicitation, form a part of this drawing to the extent specified herein.

SPECIFICATION

MILITARY

MIL-I-38535 - Integrated Circuits, Manufacturing, General Specification for.

STANDARDS

MILITARY

- MIL-STD-883 - Test Methods and Procedures for Microelectronics.
- MIL-STD-973 - Configuration Management.
- MIL-STD-1835 - Microcircuit Case Outlines.

- 1/ Stresses above the absolute maximum rating may cause permanent damage to the device. Extended operation at the maximum levels may degrade performance and affect reliability.
- 2/ Unless otherwise noted, all voltages are referenced to GND.
- 3/ The limits for the parameters specified herein shall apply over the full specified  $V_{CC}$  range and case temperature range of -55°C to +125°C unless otherwise noted.
- 4/ If device power exceeds package dissipation capability, provide heat sinking or derate linearly (the derating is based on  $\theta_{JA}$ ) at the following rate:
 

Case outline E	13.7 mW/°C
Case outline X	8.8 mW/°C
- 5/ Guaranteed by design or process but not tested.

STANDARD MICROCIRCUIT DRAWING DEFENSE ELECTRONICS SUPPLY CENTER DAYTON, OHIO 45444	SIZE <b>A</b>		<b>5962-95754</b>
		REVISION LEVEL	SHEET <b>3</b>

DESC FORM 193A  
JUL 94

■ 9004708 0015495 383 ■

BULLETIN

MILITARY

查询"5962R9575401VEC"供应商  
MIL-BUL-103 List of Standardized Military Drawings (SMD's).

HANDBOOK

MILITARY

MIL-HDBK-780 - Standardized Military Drawings.

(Copies of the specification, standards, bulletin, and handbook required by manufacturers in connection with specific acquisition functions should be obtained from the contracting activity or as directed by the contracting activity.)

2.2 Order of precedence. In the event of a conflict between the text of this drawing and the references cited herein, the text of this drawing shall take precedence.

3. REQUIREMENTS

3.1 Item requirements. The individual item requirements for device class M shall be in accordance with 1.2.1 of MIL-STD-883, "Provisions for the use of MIL-STD-883 in conjunction with compliant non-JAN devices" and as specified herein. The individual item requirements for device classes Q and V shall be in accordance with MIL-I-38535 and as specified herein or as modified in the device manufacturer's Quality Management (QM) plan. The modification in the QM plan shall not affect the form, fit, or function as described herein.

3.2 Design, construction, and physical dimensions. The design, construction, and physical dimensions shall be as specified in MIL-STD-883 (see 3.1 herein) for device class M and MIL-I-38535 for device classes Q and V and herein.

3.2.1 Case outlines. The case outlines shall be in accordance with 1.2.4 herein.

3.2.2 Terminal connections. The terminal connections shall be as specified on figure 1.

3.2.3 Truth table. The truth table shall be as specified on figure 2.

3.2.4 Logic diagram. The logic diagram shall be as specified on figure 3.

3.2.5 Switching waveforms and test circuit. The switching waveforms and test circuit shall be as specified on figure 4.

3.2.6 Irradiation test connections. The irradiation test connections shall be as specified in table III.

3.3 Electrical performance characteristics and postirradiation parameter limits. Unless otherwise specified herein, the electrical performance characteristics and postirradiation parameter limits are as specified in table I and shall apply over the full case operating temperature range.

3.4 Electrical test requirements. The electrical test requirements shall be the subgroups specified in table IIA. The electrical tests for each subgroup are defined in table I.

3.5 Marking. The part shall be marked with the PIN listed in 1.2 herein. Marking for device class M shall be in accordance with MIL-STD-883 (see 3.1 herein). In addition, the manufacturer's PIN may also be marked as listed in MIL-BUL-103. Marking for device classes Q and V shall be in accordance with MIL-I-38535.

3.5.1 Certification/compliance mark. The compliance mark for device class M shall be a "C" as required in MIL-STD-883 (see 3.1 herein). The certification mark for device classes Q and V shall be a "QML" or "Q" as required in MIL-I-38535.

3.6 Certificate of compliance. For device class M, a certificate of compliance shall be required from a manufacturer in order to be listed as an approved source of supply in MIL-BUL-103 (see 6.7.2 herein). For device classes Q and V, a certificate of compliance shall be required from a QML-38535 listed manufacturer in order to supply to the requirements of this drawing (see 6.7.1 herein). The certificate of compliance submitted to DESC-EC prior to listing as an approved source of supply for this drawing shall affirm that the manufacturer's product meets, for device class M, the requirements of MIL-STD-883 (see 3.1 herein), or for device classes Q and V, the requirements of MIL-I-38535 and the requirements herein.

3.7 Certificate of conformance. A certificate of conformance as required for device class M in MIL-STD-883 (see 3.1 herein) or for device classes Q and V in MIL-I-38535 shall be provided with each lot of microcircuits delivered to this drawing.

STANDARD MICROCIRCUIT DRAWING DEFENSE ELECTRONICS SUPPLY CENTER DAYTON, OHIO 45444	SIZE A		5962-95754
		REVISION LEVEL	SHEET 4

DESC FORM 193A  
JUL 94

■ 9004708 0015496 21T ■

TABLE I. Electrical performance characteristics.  
[查询"5962R9575401VEC"供应商](#)

Test	Symbol	Test conditions 1/ -55°C ≤ T <sub>C</sub> ≤ +125°C unless otherwise specified	Device type	V <sub>CC</sub>	Group A subgroups	Limits 2/		Unit		
						Min	Max			
High level output voltage	V <sub>OH</sub>	For all inputs affecting output under test V <sub>IN</sub> = 2.25 V or 0.8 V For all other inputs V <sub>IN</sub> = V <sub>CC</sub> or GND I <sub>OH</sub> = -50 μA	All	4.5 V	1, 2, 3	4.40		V		
			M, D, L, R 3/		All	1	4.40			
			For all inputs affecting output under test V <sub>IN</sub> = 2.75 V or 0.8 V For all other inputs V <sub>IN</sub> = V <sub>CC</sub> or GND I <sub>OH</sub> = -50 μA		All	5.5 V	1, 2, 3		5.40	
		M, D, L, R 3/		All	1		5.40			
		Low level output voltage		V <sub>OL</sub>	For all inputs affecting output under test V <sub>IN</sub> = 2.25 V or 0.8 V For all other inputs V <sub>IN</sub> = V <sub>CC</sub> or GND I <sub>OL</sub> = 50 μA		All	4.5 V	1, 2, 3	
			M, D, L, R 3/			All	1			0.1
For all inputs affecting output under test V <sub>IN</sub> = 2.75 V or 0.8 V For all other inputs V <sub>IN</sub> = V <sub>CC</sub> or GND I <sub>OL</sub> = 50 μA	All		5.5 V			1, 2, 3			0.1	
	M, D, L, R 3/	All		1		0.1				
	Input current high	I <sub>IH</sub>		For input under test, V <sub>IN</sub> = 5.5 V For all other inputs V <sub>IN</sub> = V <sub>CC</sub> or GND	All	5.5 V	1		+0.5	μA
2, 3							+5.0			
M, D, L, R 3/			All				1		+5.0	
Input current low	I <sub>IL</sub>	For input under test, V <sub>IN</sub> = GND For all other inputs V <sub>IN</sub> = V <sub>CC</sub> or GND	All	5.5 V	1		-0.5	μA		
					2, 3		-5.0			
					M, D, L, R 3/	All	1			-5.0

See footnotes at end of table.

<b>STANDARD          MICROCIRCUIT DRAWING          DEFENSE ELECTRONICS SUPPLY CENTER          DAYTON, OHIO 45444</b>	<b>SIZE          A</b>		<b>5962-95754</b>
		REVISION LEVEL	SHEET <b>5</b>

DESC FORM 193A  
 JUL 94

9004708 0015497 156

TABLE I. Electrical performance characteristics - Continued.

Test	Symbol	Test conditions 1/ 55°C ≤ T <sub>C</sub> ≤ +125°C unless otherwise specified	Device type	V <sub>CC</sub>	Group A subgroups	Limits 2/		Unit			
						Min	Max				
Output current high (Source)	I <sub>OH</sub>	For all inputs affecting output under test, V <sub>IN</sub> = 4.5 V or 0.0 V For all other inputs V <sub>IN</sub> = V <sub>CC</sub> or GND V <sub>OUT</sub> = 4.1 V	All	4.5 V	1	-4.8		mA			
									2, 3	-4.0	
									M, D, L, R 3/	All	1
Output current low (Sink)	I <sub>OL</sub>	For all inputs affecting output under test, V <sub>IN</sub> = 4.5 V or 0.0 V For all other inputs V <sub>IN</sub> = V <sub>CC</sub> or GND V <sub>OUT</sub> = 0.4 V	All	4.5 V	1	+4.8		mA			
									2, 3	+4.0	
									M, D, L, R 3/	All	1
Quiescent supply current delta, TTL input levels	ΔI <sub>CC</sub> 4/	For inputs under test V <sub>IN</sub> = V <sub>CC</sub> - 2.1 V For all other inputs V <sub>IN</sub> = V <sub>CC</sub> or GND	All	5.5 V	1, 2, 3		1.6	mA			
									M, D, L, R 3/ 4/	All	1
Quiescent supply current	I <sub>CC</sub>	V <sub>IN</sub> = V <sub>CC</sub> or GND	All	5.5 V	1		40	μA			
									2, 3	750	
									M, D, L, R 3/	All	1
Input capacitance	C <sub>IN</sub>	V <sub>IH</sub> = 5.0 V, V <sub>IL</sub> = 0.0 V f = 1 MHz See 4.4.1c	All	5.0 V	4		10	pF			
Power dissipation capacitance	C <sub>PD</sub> 5/		All	5.0 V	4		75	pF			
									5, 6	90	
Functional test	6/	V <sub>IH</sub> = 2.25 V, V <sub>IL</sub> = 0.80 V See 4.4.1b	All	4.5 V	7, 8	L	H				
									M, D, L, R 3/	All	7
Propagation delay time, min to mY	t <sub>PHL1</sub> Z/	C <sub>L</sub> = 50 pF R <sub>L</sub> = 500Ω See figure 4	All	4.5 V	9	2.0	30.0	ns			
									10, 11	2.0	34.0
	t <sub>PLH1</sub> Z/	C <sub>L</sub> = 50 pF R <sub>L</sub> = 500Ω See figure 4	All	4.5 V	9	2.0	20.0	ns			
									10, 11	2.0	23.0
					9	2.0	23.0				

See footnotes at end of table.

STANDARD MICROCIRCUIT DRAWING DEFENSE ELECTRONICS SUPPLY CENTER DAYTON, OHIO 45444	SIZE <b>A</b>		5962-95754
		REVISION LEVEL	SHEET 6

DESC FORM 193A  
JUL 94

9004708 0015498 092

TABLE I. Electrical performance characteristics - Continued.

Test Symbol	Test conditions 1/ -55°C ≤ T <sub>c</sub> ≤ +125°C unless otherwise specified	Device type	V <sub>CC</sub>	Group A subgroups	Limits 2/		Unit	
					Min	Max		
Propagation delay time, S <sub>n</sub> to mY	t <sub>PHL2</sub> Z/	C <sub>L</sub> = 50 pF R <sub>L</sub> = 500Ω See figure 4	All	4.5 V	9	2.0	39.0	ns
						10, 11	46.0	
						M, D, L, R 3/	All	
	t <sub>PLH2</sub> Z/	C <sub>L</sub> = 50 pF R <sub>L</sub> = 500Ω See figure 4	All	4.5 V	9	2.0	28.0	ns
						10, 11	32.0	
						M, D, L, R 3/	All	
Propagation delay time, mE to mY	t <sub>PHL3</sub> Z/	C <sub>L</sub> = 50 pF R <sub>L</sub> = 500Ω See figure 4	All	4.5 V	9	2.0	17.0	ns
						10, 11	19.0	
						M, D, L, R 3/	All	
	t <sub>PLH3</sub> Z/	C <sub>L</sub> = 50 pF R <sub>L</sub> = 500Ω See figure 4	All	4.5 V	9	2.0	19.0	ns
						10, 11	22.0	
						M, D, L, R 3/	All	
Output transition time	t <sub>THL</sub> , t <sub>TLH</sub> 8/	C <sub>L</sub> = 50 pF R <sub>L</sub> = 500Ω See figure 4	All	4.5 V	9	15.0	ns	
					10, 11	22.0		

- 1/ Each input/output, as applicable, shall be tested at the specified temperature, for the specified limits, to the tests in table I herein. Output terminals not designated shall be high level logic, low level logic, or open, except for the I<sub>CC</sub> and ΔI<sub>CC</sub> tests, the output terminals shall be open. When performing the I<sub>CC</sub> and ΔI<sub>CC</sub> tests, the current meter shall be placed in the circuit such that all current flows through the meter.
- 2/ For negative and positive voltage and current values, the sign designates the potential difference in reference to GND and the direction of current flow respectively; and the absolute value of the magnitude, not the sign, is relative to the minimum and maximum limits, as applicable, listed herein.
- 3/ Devices supplied to this drawing meet all levels M, D, L, and R of irradiation. However, this device is only tested at the R level. Pre and post irradiation values are identical unless otherwise specified in table I. When performing post irradiation electrical measurements for any RHA level, T<sub>A</sub> = +25°C.
- 4/ This parameter is guaranteed, if not tested, to the limits specified in table I herein.
- 5/ Power dissipation capacitance (C<sub>PD</sub>) determines both the power consumption (P<sub>D</sub>) and current consumption (I<sub>S</sub>).  
Where  

$$P_D = (C_{PD} + C_L) (V_{CC} \times V_{CC})f + (I_{CC} \times V_{CC}) + (n \times d \times \Delta I_{CC} \times V_{CC})$$

$$I_S = (C_{PD} + C_L) V_{CC}f + I_{CC} + (n \times d \times \Delta I_{CC})$$
 f is the frequency of the input signal; n is the number of device inputs at TTL levels; and d is the duty cycle of the input signal.
- 6/ The test vectors used to verify the truth table shall, at a minimum, test all functions of each input and output. All possible input to output logic patterns per function shall be guaranteed, if not tested, to the truth table in figure 2 herein. For V<sub>OUT</sub> measurements, L ≤ 0.5 V and H ≥ 4.0 V.
- 7/ AC limits at V<sub>CC</sub> = 5.5 V are equal to the limits at V<sub>CC</sub> = 4.5 V. For propagation delay tests, all paths must be tested.
- 8/ This parameter is guaranteed but not tested. This parameter is characterized upon initial design or process changes which affect this characteristic.

STANDARD MICROCIRCUIT DRAWING DEFENSE ELECTRONICS SUPPLY CENTER DAYTON, OHIO 45444	SIZE A		5962-95754
		REVISION LEVEL	SHEET 7

DESC FORM 193A  
JUL 94

■ 9004708 0015499 T29 ■

查询"5962R9575401VEC"供应商

Device type	01
Case outlines	E and X
Terminal number	Terminal symbol
1	$\overline{TE}$
2	S1
3	113
4	112
5	111
6	110
7	1Y
8	GND
9	2Y
10	210
11	211
12	212
13	213
14	S0
15	$\overline{2E}$
16	V <sub>CC</sub>

FIGURE 1. Terminal connections.

Select inputs		Data inputs				Enable inputs	Outputs
S1	S0	m10	m11	m12	m13	$\overline{mE}$	mY
X	X	X	X	X	X	H	L
L	L	L	X	X	X	L	L
L	L	H	X	X	X	L	H
L	H	X	L	X	X	L	L
L	H	X	H	X	X	L	H
H	L	X	X	L	X	L	L
H	L	X	X	H	X	L	H
H	H	X	X	X	L	L	L
H	H	X	X	X	H	L	H

NOTE: Select inputs S1 and S0 are common to both sections.

H = High voltage level  
 L = Low voltage level  
 X = Don't care

FIGURE 2. Truth table.

<b>STANDARD          MICROCIRCUIT DRAWING          DEFENSE ELECTRONICS SUPPLY CENTER          DAYTON, OHIO 45444</b>	<b>SIZE          A</b>		<b>5962-95754</b>
		REVISION LEVEL	SHEET <b>8</b>

DESC FORM 193A  
 JUL 94

■ 9004708 0015500 570 ■



查询"5962R9575401VEC"供应商

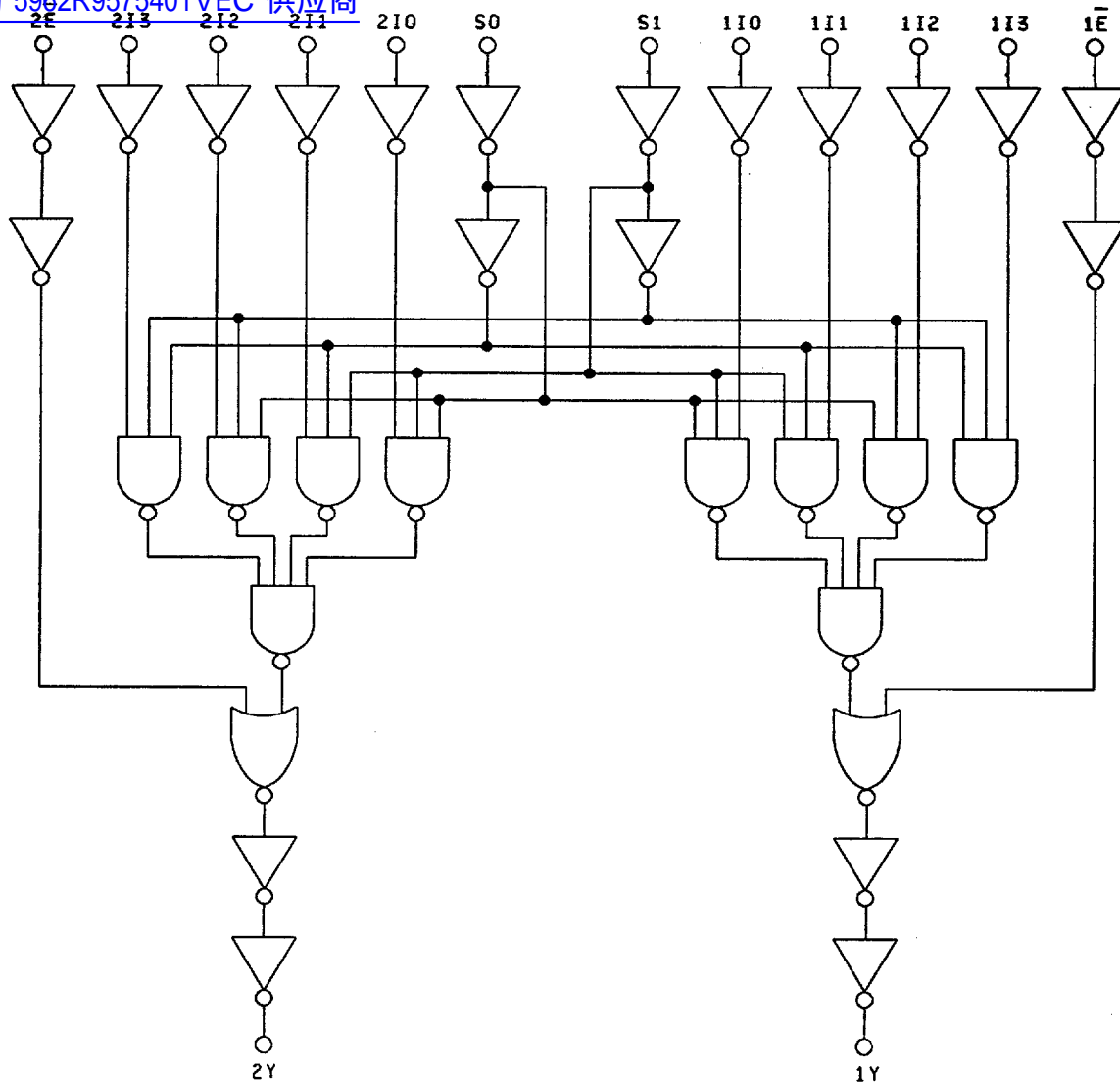

FIGURE 3. Logic diagram.

STANDARD MICROCIRCUIT DRAWING DEFENSE ELECTRONICS SUPPLY CENTER DAYTON, OHIO 45444	SIZE <b>A</b>		<b>5962-95754</b>
		REVISION LEVEL	SHEET <b>9</b>

DESC FORM 193A  
 JUL 94

■ 9004708 0015501 407 ■

查询"5962R9575401VEC"供应商

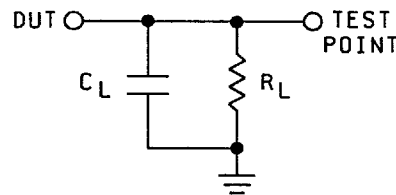
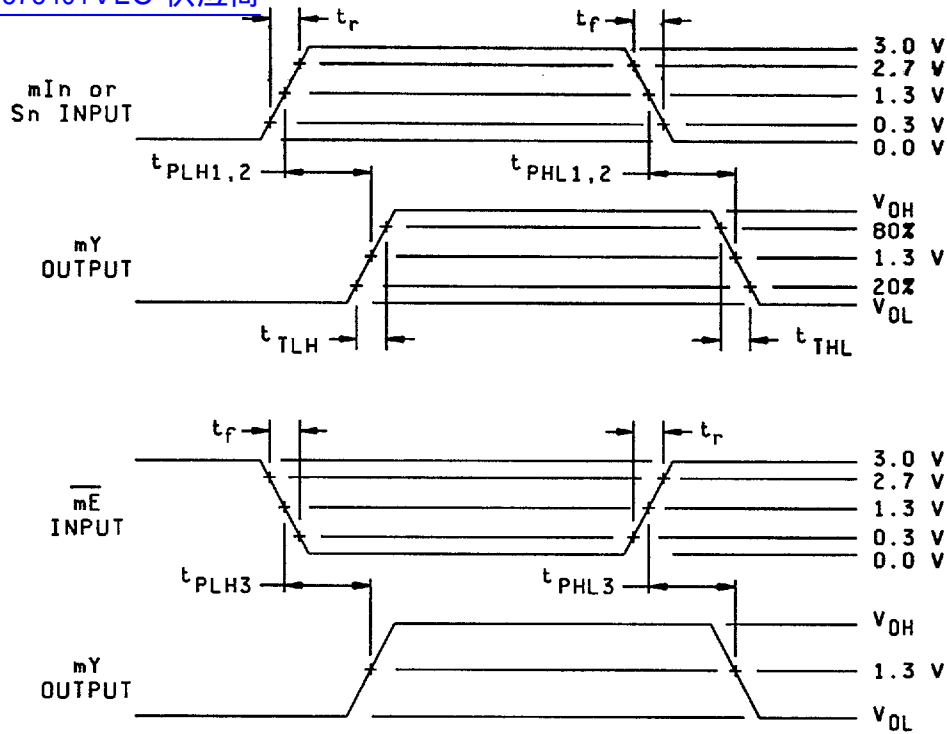

NOTES:

1.  $C_L = 50$  pF minimum or equivalent (includes test jig and probe capacitance).
2.  $R_L = 500\Omega$  or equivalent.
3. Input signal from pulse generator:  $V_{IN} = 0.0$  V to 3.0 V;  $PRR \leq 10$  MHz;  $t_r \leq 3.0$  ns;  $t_f \leq 3.0$  ns;  $t_r$  and  $t_f$  shall be measured from 0.3 V to 2.7 V and from 2.7 V to 0.3 V, respectively.

FIGURE 4. Switching waveforms and test circuit.

STANDARD MICROCIRCUIT DRAWING DEFENSE ELECTRONICS SUPPLY CENTER DAYTON, OHIO 45444	SIZE <b>A</b>	<b>5962-95754</b>
	REVISION LEVEL	SHEET <b>10</b>

DESC FORM 193A  
JUL 94

9004708 0015502 343

3.8 Notification of change for device class M. For device class M, notification to DESC-EC of change of product (see 6.2 herein) involving devices acquired to this drawing is required for any change as defined in MIL-STD-973.

3. Verification and Review for device class M. For device class M, DESC, DESC's agent, and the acquiring activity retain the option to review the manufacturer's facility and applicable required documentation. Offshore documentation shall be made available onshore at the option of the reviewer.

3.10 Microcircuit group assignment for device class M. Device class M devices covered by this drawing shall be in microcircuit group number 39 (see MIL-I-38535, appendix A).

#### 4. QUALITY ASSURANCE PROVISIONS

4.1 Sampling and inspection. For device class M, sampling and inspection procedures shall be in accordance with MIL-STD-883 (see 3.1 herein). For device classes Q and V, sampling and inspection procedures shall be in accordance with MIL-I-38535 or as modified in the device manufacturer's Quality Management (QM) plan. The modification in the QM plan shall not affect the form, fit, or function as described herein.

4.2 Screening. For device class M, screening shall be in accordance with method 5004 of MIL-STD-883, and shall be conducted on all devices prior to quality conformance inspection. For device classes Q and V, screening shall be in accordance with MIL-I-38535, and shall be conducted on all devices prior to qualification and technology conformance inspection.

##### 4.2.1 Additional criteria for device class M.

a. Burn-in test, method 1015 of MIL-STD-883.

(1) Test condition A, B, C or D. The test circuit shall be maintained by the manufacturer under document revision level control and shall be made available to the preparing or acquiring activity upon request. The test circuit shall specify the inputs, outputs, biases, and power dissipation, as applicable, in accordance with the intent specified in test method 1015.

(2)  $T_A = +125^\circ\text{C}$ , minimum.

b. Interim and final electrical test parameters shall be as specified in table IIA herein.

##### 4.2.2 Additional criteria for device classes Q and V.

a. The burn-in test duration, test condition and test temperature, or approved alternatives shall be as specified in the device manufacturer's QM plan in accordance with MIL-I-38535. The burn-in test circuit shall be maintained under document revision level control of the device manufacturer's Technology Review Board (TRB) in accordance with MIL-I-38535 and shall be made available to the acquiring or preparing activity upon request. The test circuit shall specify the inputs, outputs, biases, and power dissipation, as applicable, in accordance with the intent specified in test method 1015.

b. Interim and final electrical test parameters shall be as specified in table IIA herein.

c. Additional screening for device class V beyond the requirements of device class Q shall be as specified in appendix B of MIL-I-38535 or as modified in the device manufacturer's Quality Management (QM) plan.

4.3 Qualification inspection for device classes Q and V. Qualification inspection for device classes Q and V shall be in accordance with MIL-I-38535. Inspections to be performed shall be those specified in MIL-I-38535 and herein for groups A, B, C, D, and E inspections (see 4.4.1 through 4.4.4).

4.3.1 Electrostatic discharge sensitivity (ESDS) qualification inspection. ESDS testing shall be performed in accordance with MIL-STD-883, method 3015. ESDS testing shall be measured only for initial qualification and after process or design changes which may affect ESDS classification.

4.4 Conformance inspection. Quality conformance inspection for device class M shall be in accordance with MIL-STD-883 (see 3.1 herein) and as specified herein. Inspections to be performed for device class M shall be those specified in method 5005 of MIL-STD-883 and herein for groups A, B, C, D, and E inspections (see 4.4.1 through 4.4.4). Technology conformance inspection for classes Q and V shall be in accordance with MIL-I-38535 or as specified in QM plan including groups A, B, C, D, and E inspections and as specified herein except where option 2 of MIL-I-38535 permits alternate in-line control testing.

STANDARD MICROCIRCUIT DRAWING DEFENSE ELECTRONICS SUPPLY CENTER DAYTON, OHIO 45444	SIZE A		5962-95754
		REVISION LEVEL	SHEET 11

DESC FORM 193A  
JUL 94

■ 9004708 0015503 28T ■

4.4.1 Group A inspection.

a. Tests shall be as specified in table IIA herein.

~~b. For device class M, subgroups 7 and 8 tests shall be sufficient to verify the truth table in figure 2 herein.~~  
 查询"5962R9575401VEC"供应商

For device classes Q and V, subgroups 7 and 8 shall include verifying the functionality of the device.

c.  $C_{IN}$  and  $C_{PD}$  shall be measured only for initial qualification and after process or design changes which may affect capacitance.  $C_{IN}$  shall be measured between the designated terminal and GND at a frequency of 1 MHz. For  $C_{IN}$  and  $C_{PD}$ , tests shall be sufficient to validate the limits defined in table I herein.

4.4.2 Group C inspection. The group C inspection end-point electrical parameters shall be as specified in table IIA herein.

TABLE IIA. Electrical test requirements.

Test requirements	Subgroups (in accordance with MIL-STD-883, TM 5005, table I)	Subgroups (in accordance with MIL-I-38535, table III)	
	Device class M	Device class Q	Device class V
Interim electrical parameters (see 4.2)	1, 7, 9	1, 7, 9	1, 7, 9
Final electrical parameters (see 4.2)	1, 2, 3, 7, 8, 9, 10, 11 1/	1, 2, 3, 7, 8, 9, 10, 11 1/	1, 2, 3, 7, 8, 9, 10, 11 2/ 3/
Group A test requirements (see 4.4)	1, 2, 3, 4, 5, 6, 7, 8, 9, 10, 11	1, 2, 3, 4, 5, 6, 7, 8, 9, 10, 11	1, 2, 3, 4, 5, 6, 7, 8, 9, 10, 11
Group C end-point electrical parameters (see 4.4)	1, 2, 3, 7, 8, 9, 10, 11	1, 2, 3, 7, 8, 9, 10, 11	1, 2, 3, 7, 8, 9, 10, 11 3/
Group D end-point electrical parameters (see 4.4)	1, 7, 9	1, 7, 9	1, 7, 9
Group E end-point electrical parameters (see 4.4)	1, 7, 9	1, 7, 9	1, 7, 9

1/ PDA applies to subgroups 1 and 7.

2/ PDA applies to subgroups 1, 7, 9, and deltas.

3/ Delta limits as specified in table IIB herein shall be required where specified, and the delta values shall be completed with reference to the zero hour electrical parameters (see table I).

TABLE IIB. Burn-in and operating life test. Delta parameters (+25°C).

Parameters 1/	Delta limits
$I_{CC}$	+12 $\mu$ A
$I_{OL}/I_{OH}$	-15 %

1/ These parameters shall be recorded before and after the required burn-in and life test to determine delta limits.

STANDARD MICROCIRCUIT DRAWING DEFENSE ELECTRONICS SUPPLY CENTER DAYTON, OHIO 45444	SIZE <b>A</b>		5962-95754
		REVISION LEVEL	SHEET 12

4.4.2.1 Additional criteria for device class M. Steady-state life test conditions, method 1005 of MIL-STD-883:

- a. Test condition A, B, C or D. The test circuit shall be maintained by the manufacturer under document revision control and shall be made available to the preparing or acquiring activity upon request. The test circuit shall specify the inputs, outputs, biases, and power dissipation, as applicable, in accordance with the intent specified in test method 1005.
- b.  $T_A = +125^\circ\text{C}$ , minimum.
- c. Test duration: 1,000 hours, except as permitted by method 1005 of MIL-STD-883.

4.4.2.2 Additional criteria for device classes Q and V. The steady-state life test duration, test condition and test temperature, or approved alternatives shall be as specified in the device manufacturer's QM plan in accordance with MIL-I-38535. The test circuit shall be maintained under document revision level control by the device manufacturer's TRB, in accordance with MIL-I-38535, and shall be made available to the acquiring or preparing activity upon request. The test circuit shall specify the inputs, outputs, biases, and power dissipation, as applicable, in accordance with the intent specified in test method 1005.

4.4.3 Group D inspection. The group D inspection end-point electrical parameters shall be as specified in table IIA herein.

4.4.4 Group E inspection. Group E inspection is required only for parts intended to be marked as radiation hardness assured (see 3.5 herein). RHA levels for device classes M, Q, and V shall be as specified in MIL-I-38535. End-point electrical parameters shall be as specified in table IIA herein.

4.4.4.1 Total dose irradiation testing. Total dose irradiation testing shall be performed in accordance with MIL-STD-883, test method 1019 and as specified herein.

4.4.4.1.1 Accelerated aging testing. Accelerated aging testing shall be performed on all devices requiring a RHA level greater than 5k rads (Si). The post-anneal end-point electrical parameter limits shall be as specified in table I herein and shall be the pre-irradiation end-point electrical parameter limit at  $25^\circ\text{C} \pm 5^\circ\text{C}$ . Testing shall be performed at initial qualification and after any design or process changes which may affect the RHA response of the device.

4.4.4.2 Dose rate induced latchup testing. Dose rate induced latchup testing shall be performed in accordance with test method 1020 of MIL-STD-883 and as specified herein (see 1.4 herein). Tests shall be performed on devices, SEC, or approved test structures at technology qualification and after any design or process changes which may affect the RHA capability of the process.

4.4.4.3 Dose rate upset testing. Dose rate upset testing shall be performed in accordance with method 1021 of MIL-STD-883 and herein (see 1.4 herein).

- a. Transient dose rate upset testing shall be performed at initial qualification and after any design or process changes which may affect the RHA performance of the devices. Test 10 devices with 0 defects unless otherwise specified.
- b. Transient dose rate upset testing for class Q and V devices shall be performed as specified by a TRB approved radiation hardness assurance plan and MIL-I-38535.

TABLE III. Irradiation test connections.

Open	Ground	$V_{CC} = 5\text{ V} \pm 0.5\text{ V}$
7, 9	8	1, 2, 3, 4, 5, 6, 10, 11, 12, 13, 14, 15, 16

NOTE: Each pin except  $V_{CC}$  and GND will have a resistor of  $47\text{ k}\Omega \pm 5\%$  for irradiation testing.

STANDARD MICROCIRCUIT DRAWING DEFENSE ELECTRONICS SUPPLY CENTER DAYTON, OHIO 45444	SIZE <b>A</b>		5962-95754
		REVISION LEVEL	SHEET 13

DESC FORM 193A  
JUL 94

9004708 0015505 052

4.4.4.4 Single event phenomena (SEP). SEP testing shall be required on class V devices (see 1.4 herein). SEP testing shall be performed on a technology process on the Standard Evaluation Circuit (SEC) or alternate SEP test vehicle as approved by the qualifying activity at initial qualification and after any design or process changes which may affect 5962-9575401-0101 characteristics. The recommended test conditions for SEP are as follows:

- a. The ion beam angle of incidence shall be between normal to the die surface and 60° to the normal, inclusive (i.e. 0° ≤ angle ≤ 60°). No shadowing of the ion beam due to fixturing or package related effects is allowed.
- b. The fluence shall be ≥ 100 errors or ≥ 10<sup>6</sup> ions/cm<sup>2</sup>.
- c. The flux shall be between 10<sup>2</sup> and 10<sup>5</sup> ions/cm<sup>2</sup>/s. The cross-section shall be verified to be flux independent by measuring the cross-section at two flux rates which differ by at least an order of magnitude.
- d. The particle range shall be ≥ 20 micron in silicon.
- e. The test temperature shall be +25°C and the maximum rated operating temperature ±10°C.
- f. Bias conditions shall be defined by the manufacturer for the latchup measurements.
- g. Test four devices with zero failures.

4.5 Methods of inspection. Methods of inspection shall be specified as follows:

4.5.1 Voltage and current. Unless otherwise specified, all voltages given are referenced to the microcircuit GND terminal. Currents given are conventional current and positive when flowing into the referenced terminal.

5. PACKAGING

5.1 Packaging requirements. The requirements for packaging shall be in accordance with MIL-STD-883 (see 3.1 herein) for device class M and MIL-1-38535 for device classes Q and V.

6. NOTES

6.1 Intended use. Microcircuits conforming to this drawing are intended for use for Government microcircuit applications (original equipment), design applications, and logistics purposes.

6.1.1 Replaceability. Microcircuits covered by this drawing will replace the same generic device covered by a contractor-prepared specification or drawing.

6.1.2 Substitutability. Device class Q devices will replace device class M devices.

6.2 Configuration control of SMD's. All proposed changes to existing SMD's will be coordinated with the users of record for the individual documents. This coordination will be accomplished in accordance with MIL-STD-973 using DD Form 1692, Engineering Change Proposal.

6.3 Record of users. Military and industrial users shall inform Defense Electronics Supply Center when a system application requires configuration control and which SMD's are applicable to that system. DESC will maintain a record of users and this list will be used for coordination and distribution of changes to the drawings. Users of drawings covering microelectronic devices (FSC 5962) should contact DESC-EC, telephone (513) 296-6047.

6.4 Comments. Comments on this drawing should be directed to DESC-EC, Dayton, Ohio 45444-5270, or telephone (513) 296-5377.

6.5 Abbreviations, symbols, and definitions. The abbreviations, symbols, and definitions used herein are defined in MIL-1-38535 and MIL-STD-1331, and as follows:

- GND . . . . . Ground zero voltage potential.
- I<sub>CC</sub> . . . . . Quiescent supply current.
- I<sub>IL</sub> . . . . . Input current low.
- I<sub>IH</sub> . . . . . Input current high.
- T<sub>A</sub> . . . . . Ambient temperature.
- T<sub>C</sub> . . . . . Case temperature.
- V<sub>CC</sub> . . . . . Positive supply voltage.
- C<sub>IN</sub> . . . . . Input terminal-to-GND capacitance.
- C<sub>PD</sub> . . . . . Power dissipation capacitance.

<b>STANDARD MICROCIRCUIT DRAWING DEFENSE ELECTRONICS SUPPLY CENTER DAYTON, OHIO 45444</b>	<b>SIZE A</b>		<b>5962-95754</b>
		<b>REVISION LEVEL</b>	<b>SHEET 14</b>

DESC FORM 193A  
JUL 94

■ 9004708 0015506 T99 ■

6.6 One part - one part number system. The one part - one part number system described below has been developed to allow for transitions between identical generic devices covered by the three major microcircuit requirements documents (MIL-H-38534, MIL-I-38535, and 1.2.1 of MIL-STD-883) without the necessity for the generation of unique PIN's. The three military requirements documents represent different class levels, and previously when a device manufacturer upgraded military product from one class level to another, the benefits of the upgraded product were unavailable to the Original Equipment Manufacturer (OEM), that was contractually locked into the original unique PIN. By establishing a one part number system covering all three documents, the OEM can acquire to the highest class level available for a given generic device to meet system needs without modifying the original contract parts selection criteria.

<u>Military documentation format</u>	<u>Example PIN under new system</u>	<u>Manufacturing source listing</u>	<u>Document listing</u>
New MIL-H-38534 Standard Microcircuit Drawings	5962-XXXXXZZ(H or K)YY	QML-38534	MIL-BUL-103
New MIL-I-38535 Standard Microcircuit Drawings	5962-XXXXXZZ(Q or V)YY	QML-38535	MIL-BUL-103
New 1.2.1 of MIL-STD-883 Standard Microcircuit Drawings	5962-XXXXXZZ(M)YY	MIL-BUL-103	MIL-BUL-103

6.7 Sources of supply.

6.7.1 Sources of supply for device classes Q and V. Sources of supply for device classes Q and V are listed in QML-38535. The vendors listed in QML-38535 have submitted a certificate of compliance (see 3.6 herein) to DESC-EC and have agreed to this drawing.

6.7.2 Approved sources of supply for device class M. Approved sources of supply for class M are listed in MIL-BUL-103. The vendors listed in MIL-BUL-103 have agreed to this drawing and a certificate of compliance (see 3.6 herein) has been submitted to and accepted by DESC-EC.

6.8 Additional information. A copy of the following additional data shall be maintained and available from the device manufacturer:

- a. RHA upset levels.
- b. Test conditions (SEP).
- c. Number of upsets (SEP).
- d. Number of transients (SEP).
- e. Occurrence of latchup (SEP).

<b>STANDARD MICROCIRCUIT DRAWING DEFENSE ELECTRONICS SUPPLY CENTER DAYTON, OHIO 45444</b>	<b>SIZE A</b>		<b>5962-95754</b>
		<b>REVISION LEVEL</b>	<b>SHEET 15</b>

DESC FORM 193A  
JUL 94

: ■ 9004708 0015507 925 ■