

## 16-BIT DUAL-SUPPLY BUS TRANSCEIVER WITH CONFIGURABLE VOLTAGE TRANSLATION AND 3-STATE OUTPUTS

### FEATURES

- Control Inputs  $V_{IH}/V_{IL}$  Levels Are Referenced to  $V_{CCA}$  Voltage
- $V_{CC}$  Isolation Feature – If Either  $V_{CC}$  Input Is at GND, All Outputs Are in the High-Impedance State
- Overvoltage-Tolerant Inputs/Outputs Allow Mixed-Voltage-Mode Data Communications
- Fully Configurable Dual-Rail Design Allows Each Port to Operate Over the Full 1.65-V to 5.5-V Power-Supply Range
- Bus Hold on Data Inputs Eliminates the Need for External Pullup/Pulldown Resistors
- $I_{off}$  Supports Partial-Power-Down Mode Operation
- Latch-Up Performance Exceeds 100 mA Per JESD 78, Class II
- ESD Protection Exceeds JESD 22
  - 2000-V Human-Body Model (A114-A)
  - 200-V Machine Model (A115-A)
  - 1000-V Charged-Device Model (C101)

### SUPPORTS DEFENSE, AEROSPACE, AND MEDICAL APPLICATIONS

- Controlled Baseline
- One Assembly/Test Site
- One Fabrication Site
- Available in Military ( $-55^{\circ}\text{C}/125^{\circ}\text{C}$ ) Temperature Ranges<sup>(1)</sup>
- Extended Product Life Cycle
- Extended Product-Change Notification
- Product Traceability

(1) Additional temperature ranges are available – contact factory

### DESCRIPTION/ORDERING INFORMATION

This 16-bit noninverting bus transceiver uses two separate configurable power-supply rails. The A port is designed to track  $V_{CCA}$ .  $V_{CCA}$  accepts any supply voltage from 1.65 V to 5.5 V. The B port is designed to track  $V_{CCB}$ .  $V_{CCB}$  accepts any supply voltage from 1.65 V to 5.5 V. This allows for universal low-voltage bidirectional translation between any of the 1.8-V, 2.5-V, 3.3-V, and 5-V voltage nodes.

The SN74LVCH16T245 is designed so that the control pins (1DIR, 2DIR,  $1\overline{\text{OE}}$ , and  $2\overline{\text{OE}}$ ) are supplied by  $V_{CCA}$ .

DGG OR DGV PACKAGE  
(TOP VIEW)

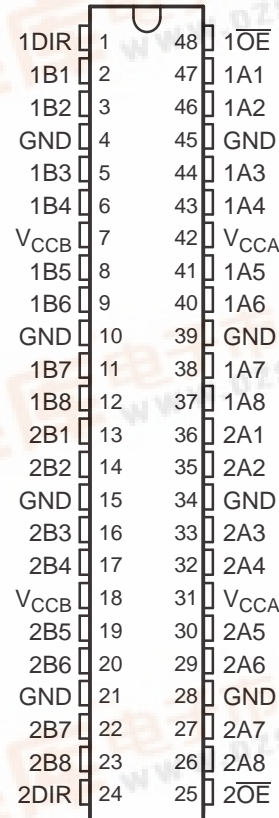

Please be aware that an important notice concerning availability, standard warranty, and use in critical applications of Texas Instruments semiconductor products and disclaimers thereto appears at the end of this data sheet.

PRODUCTION DATA information is current as of publication date. Products conform to specifications per the terms of the Texas Instruments standard warranty. Production processing does not necessarily include testing of all parameters.

Copyright © 2008, Texas Instruments Incorporated



The SN74LVCH16T245 is designed for asynchronous communication between two data buses. The logic levels of the direction-control (DIR) input and the output-enable ( $\overline{OE}$ ) input activate either the B-port outputs or the A-port outputs or place both output ports into the high-impedance mode. The device transmits data from the A bus to the B bus when the B-port outputs are activated, and from the B bus to the A bus when the A-port outputs are activated. The input circuitry on both A and B ports is always active and must have a logic HIGH or LOW level applied to prevent excess  $I_{CC}$  and  $I_{CCZ}$ .

Active bus-hold circuitry holds unused or undriven data inputs at a valid logic state. Use of pullup or pulldown resistors with the bus-hold circuitry is not recommended.

This device is fully specified for partial-power-down applications using  $I_{off}$ . The  $I_{off}$  circuitry disables the outputs, preventing damaging current backflow through the device when it is powered down.

The  $V_{CC}$  isolation feature ensures that if either  $V_{CC}$  input is at GND, then all outputs are in the high-impedance state. The bus-hold circuitry on the powered-up side always stays active.

To ensure the high-impedance state during power up or power down,  $\overline{OE}$  should be tied to  $V_{CC}$  through a pullup resistor; the minimum value of the resistor is determined by the current-sinking capability of the driver.

**ORDERING INFORMATION<sup>(1)</sup>**

$T_A$	PACKAGE <sup>(2)</sup>		ORDERABLE PART NUMBER	Top-Side Marking
-55°C to 125°C	TSSOP – DGG	Tape and reel	CLVCH16T245MDGGREP	8UT245MEP
	TVSOP – DGV	Tape and reel	CLVCH16T245MDGVREP	LDHT245MEP

(1) For the most current package and ordering information, see the Package Option Addendum at the end of this document, or see the TI web site at [www.ti.com](http://www.ti.com).

(2) Package drawings, thermal data, and symbolization are available at [www.ti.com/packaging](http://www.ti.com/packaging).

**GQL OR ZQL PACKAGE  
(TOP VIEW)**

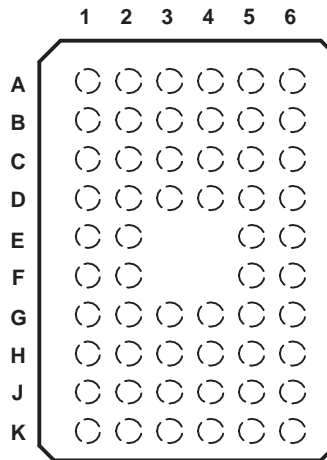



## Absolute Maximum Ratings<sup>(1)</sup>

over operating free-air temperature range (unless otherwise noted)

		MIN	MAX	UNIT	
$V_{CCA}$ $V_{CCB}$	Supply voltage range	-0.5	6.5	V	
$V_I$	Input voltage range <sup>(2)</sup>	I/O ports (A port)	-0.5	6.5	V
		I/O ports (B port)	-0.5	6.5	
		Control inputs	-0.5	6.5	
$V_O$	Voltage range applied to any output in the high-impedance or power-off state <sup>(2)</sup>	A port	-0.5	6.5	V
		B port	-0.5	6.5	
$V_O$	Voltage range applied to any output in the high or low state <sup>(2)(3)</sup>	A port	-0.5	$V_{CCA} + 0.5$	V
		B port	-0.5	$V_{CCB} + 0.5$	
$I_{IK}$	Input clamp current	$V_I < 0$	-50	mA	
$I_{OK}$	Output clamp current	$V_O < 0$	-50	mA	
$I_O$	Continuous output current		±50	mA	
		Continuous current through each $V_{CCA}$ , $V_{CCB}$ , and GND	±100	mA	
$\theta_{JA}$	Package thermal impedance <sup>(4)</sup>	DGV package	58	°C/W	
$T_{stg}$	Storage temperature range	-65	150	°C	

- (1) Stresses beyond those listed under "absolute maximum ratings" may cause permanent damage to the device. These are stress ratings only, and functional operation of the device at these or any other conditions beyond those indicated under "recommended operating conditions" is not implied. Exposure to absolute-maximum-rated conditions for extended periods may affect device reliability.
- (2) The input and output negative-voltage ratings may be exceeded if the input and output current ratings are observed.
- (3) The output positive-voltage rating may be exceeded up to 6.5 V maximum if the output current rating is observed.
- (4) The package thermal impedance is calculated in accordance with JESD 51-7.

**Recommended Operating Conditions<sup>(1)(2)(3)</sup>**

			$V_{CCI}$	$V_{CCO}$	MIN	MAX	UNIT
$V_{CCA}$	Supply voltage				1.65	5.5	V
$V_{CCB}$					1.65	5.5	
$V_{IH}$	High-level input voltage	Data inputs <sup>(4)</sup>	1.65 V to 1.95 V		$V_{CCI} \times 0.65$		V
			2.3 V to 2.7 V		1.7		
			3 V to 3.6 V		2		
			4.5 V to 5.5 V		$V_{CCI} \times 0.7$		
$V_{IL}$	Low-level input voltage	Data inputs <sup>(4)</sup>	1.65 V to 1.95 V		$V_{CCI} \times 0.35$		V
			2.3 V to 2.7 V		0.7		
			3 V to 3.6 V		0.8		
			4.5 V to 5.5 V		$V_{CCI} \times 0.3$		
$V_{IH}$	High-level input voltage	Control inputs (referenced to $V_{CCA}$ ) <sup>(5)</sup>	1.65 V to 1.95 V		$V_{CCA} \times 0.65$		V
			2.3 V to 2.7 V		1.7		
			3 V to 3.6 V		2		
			4.5 V to 5.5 V		$V_{CCA} \times 0.7$		
$V_{IL}$	Low-level input voltage	Control inputs (referenced to $V_{CCA}$ ) <sup>(5)</sup>	1.65 V to 1.95 V		$V_{CCA} \times 0.35$		V
			2.3 V to 2.7 V		0.7		
			3 V to 3.6 V		0.8		
			4.5 V to 5.5 V		$V_{CCA} \times 0.3$		
$V_I$	Input voltage	Control inputs			0	5.5	V
$V_{IO}$	Input/output voltage	Active state			0	$V_{CCO}$	V
		3-State			0	5.5	
$I_{OH}$	High-level output current		1.65 V to 1.95 V		–4		mA
			2.3 V to 2.7 V		–8		
			3 V to 3.6 V		–24		
			4.5 V to 5.5 V		–32		
$I_{OL}$	Low-level output current		1.65 V to 1.95 V		4		mA
			2.3 V to 2.7 V		8		
			3 V to 3.6 V		24		
			4.5 V to 5.5 V		32		
$\Delta t / \Delta v$	Input transition rise or fall rate	Data inputs	1.65 V to 1.95 V		20		ns/V
			2.3 V to 2.7 V		20		
			3 V to 3.6 V		10		
			4.5 V to 5.5 V		5		
$T_A$	Operating free-air temperature				–55	125	°C

(1)  $V_{CCI}$  is the  $V_{CC}$  associated with the data input port.

(2)  $V_{CCO}$  is the  $V_{CC}$  associated with the output port.

(3) All unused control inputs of the device must be held at  $V_{CCA}$  GND to ensure proper device operation and minimize power consumption. Refer to the TI application report, *Implications of Slow or Floating CMOS Inputs*, literature number SCBA004.

(4) For  $V_{CCI}$  values not specified in the data sheet,  $V_{IH}$  min =  $V_{CCI} \times 0.7$  V,  $V_{IL}$  max =  $V_{CCI} \times 0.3$  V.

(5) For  $V_{CCA}$  values not specified in the data sheet,  $V_{IH}$  min =  $V_{CCA} \times 0.7$  V,  $V_{IL}$  max =  $V_{CCA} \times 0.3$  V.

## Electrical Characteristics<sup>(1)(2)</sup>

over recommended operating free-air temperature range (unless otherwise noted)

PARAMETER		TEST CONDITIONS		V <sub>CCA</sub>	V <sub>CCB</sub>	MIN	TYP	MAX	MIN	MAX	UNIT
V <sub>OH</sub>			I <sub>OH</sub> = -100 μA, V <sub>I</sub> = V <sub>IH</sub>	1.65 V to 4.5 V	1.65 V to 4.5 V				V <sub>CCO</sub> - 0.1		V
			I <sub>OH</sub> = -4 mA, V <sub>I</sub> = V <sub>IH</sub>	1.65 V	1.65 V				1.2		
			I <sub>OH</sub> = -8 mA, V <sub>I</sub> = V <sub>IH</sub>	2.3 V	2.3 V				1.9		
			I <sub>OH</sub> = -24 mA, V <sub>I</sub> = V <sub>IH</sub>	3 V	3 V				2.4		
			I <sub>OH</sub> = -32 mA, V <sub>I</sub> = V <sub>IH</sub>	4.5 V	4.5 V				3.8		
V <sub>OL</sub>			I <sub>OL</sub> = 100 μA, V <sub>I</sub> = V <sub>IL</sub>	1.65 V to 4.5 V	1.65 V to 4.5 V				0.1		V
			I <sub>OL</sub> = 4 mA, V <sub>I</sub> = V <sub>IL</sub>	1.65 V	1.65 V				0.45		
			I <sub>OL</sub> = 8 mA, V <sub>I</sub> = V <sub>IL</sub>	2.3 V	2.3 V				0.3		
			I <sub>OL</sub> = 24 mA, V <sub>I</sub> = V <sub>IL</sub>	3 V	3 V				0.55		
			I <sub>OL</sub> = 32 mA, V <sub>I</sub> = V <sub>IL</sub>	4.5 V	4.5 V				0.55		
I <sub>I</sub>	Control inputs	V <sub>I</sub> = V <sub>CCA</sub> or GND		1.65 V to 5.5 V	1.65 V to 5.5 V		±0.5	±1		±3	μA
I <sub>BHL</sub> <sup>(3)</sup>			V <sub>I</sub> = 0.58 V	1.65 V	1.65 V				15		μA
			V <sub>I</sub> = 0.7 V	2.3 V	2.3 V				45		
			V <sub>I</sub> = 0.8 V	3 V	3 V				75		
			V <sub>I</sub> = 0.135 V	4.5 V	4.5 V				100		
I <sub>BHH</sub> <sup>(4)</sup>			V <sub>I</sub> = 1.07 V	1.65 V	1.65 V				-15		μA
			V <sub>I</sub> = 1.7 V	2.3 V	2.3 V				-45		
			V <sub>I</sub> = 2 V	3 V	3 V				-75		
			V <sub>I</sub> = 3.15 V	4.5 V	4.5 V				-100		
I <sub>BHLO</sub> <sup>(5)</sup>			V <sub>I</sub> = 0 to V <sub>CC</sub>	1.95 V	1.95 V				200		μA
				2.7 V	2.7 V				300		
				3.6 V	3.6 V				500		
				5.5 V	5.5 V				900		
I <sub>BHHO</sub> <sup>(6)</sup>			V <sub>I</sub> = 0 to V <sub>CC</sub>	1.95 V	1.95 V				-200		μA
				2.7 V	2.7 V				-300		
				3.6 V	3.6 V				-500		
				5.5 V	5.5 V				-900		
I <sub>off</sub>	A port	V <sub>I</sub> or V <sub>O</sub> = 0 to 5.5 V		0 V	0 to 5.5 V		±0.5	±1.5		±20	μA
	B port			0 to 5.5 V	0 V		±0.5	±1.5		±20	
I <sub>OZ</sub>	A or B port	V <sub>O</sub> = V <sub>CCO</sub> or GND, V <sub>I</sub> = V <sub>CCI</sub> or GND	$\overline{OE} = V_{IH}$	1.65 V to 5.5 V	1.65 V to 5.5 V			±1		±4	μA
	B port		$\overline{OE} = \text{don't care}$	0 V	5.5 V			±1		±4	
	A port			5.5 V	0 V			±1		±4	
I <sub>CCA</sub>			V <sub>I</sub> = V <sub>CCI</sub> or GND, I <sub>O</sub> = 0	1.65 V to 5.5 V	1.65 V to 5.5 V				20		μA
				5 V	0 V				20		
				0 V	5 V				-4		
I <sub>CCB</sub>			V <sub>I</sub> = V <sub>CCI</sub> or GND, I <sub>O</sub> = 0	1.65 V to 5.5 V	1.65 V to 5.5 V				20		μA
				5 V	0 V				-4		
				0 V	5 V				20		
I <sub>CCA</sub> + I <sub>CCB</sub>		V <sub>I</sub> = V <sub>CCI</sub> or GND, I <sub>O</sub> = 0		1.65 V to 5.5 V	1.65 V to 5.5 V				30		μA

(1) V<sub>CCO</sub> is the V<sub>CC</sub> associated with the output port.

(2) V<sub>CCI</sub> is the V<sub>CC</sub> associated with the input port.

(3) The bus-hold circuit can sink at least the minimum low sustaining current at V<sub>IL</sub> max. I<sub>BHL</sub> should be measured after lowering V<sub>IN</sub> to GND and then raising it to V<sub>IL</sub> max.

(4) The bus-hold circuit can source at least the minimum high sustaining current at V<sub>IH</sub> min. I<sub>BHH</sub> should be measured after raising V<sub>IN</sub> to V<sub>CC</sub> and then lowering it to V<sub>IH</sub> min.

(5) An external driver must source at least I<sub>BHLO</sub> to switch this node from low to high.

(6) An external driver must sink at least I<sub>BHHO</sub> to switch this node from high to low.

## Electrical Characteristics (continued)

over recommended operating free-air temperature range (unless otherwise noted)

PARAMETER		TEST CONDITIONS	V <sub>CCA</sub>	V <sub>CCB</sub>	MIN	TYP	MAX	MIN	MAX	UNIT
ΔI <sub>CCA</sub>	DIR	DIR at V <sub>CCA</sub> – 0.6 V, B port = open, A port at V <sub>CCA</sub> or GND	3 V to 5.5 V	3 V to 5.5 V				50		μA
C <sub>i</sub>	Control inputs	V <sub>I</sub> = V <sub>CCA</sub> or GND	3.3 V	3.3 V		4		5		pF
C <sub>io</sub>	A or B port	V <sub>O</sub> = V <sub>CCA/B</sub> or GND	3.3 V	3.3 V		8.5		10		pF

## Switching Characteristics

 over recommended operating free-air temperature range, V<sub>CCA</sub> = 1.8 V ± 0.15 V (unless otherwise noted) (see Figure 1)

PARAMETER	FROM (INPUT)	TO (OUTPUT)	V <sub>CCB</sub> = 1.8 V ± 0.15 V		V <sub>CCB</sub> = 2.5 V ± 0.2 V		V <sub>CCB</sub> = 3.3 V ± 0.3 V		V <sub>CCB</sub> = 5 V ± 0.5 V		UNIT
			MIN	MAX	MIN	MAX	MIN	MAX	MIN	MAX	
t <sub>PLH</sub>	A	B	1.7	25.9	1.3	13.2	1	11.4	0.4	11.1	ns
t <sub>PHL</sub>											
t <sub>PLH</sub>	B	A	0.9	27.8	0.8	27.8	0.7	27.4	0.7	27.4	ns
t <sub>PHL</sub>											
t <sub>PHZ</sub>	$\overline{OE}$	A	1.5	33.6	1.5	33.4	1.5	33.3	1.4	33.2	ns
t <sub>PLZ</sub>											
t <sub>PHZ</sub>	$\overline{OE}$	B	2.4	36.2	1.9	17.1	1.7	16	1.3	14.3	ns
t <sub>PLZ</sub>											
t <sub>PZH</sub>	$\overline{OE}$	A	0.4	28	0.4	27.8	0.4	27.7	0.4	27.7	ns
t <sub>PZL</sub>											
t <sub>PZH</sub>	$\overline{OE}$	B	1.8	36	1.5	22	1.2	16.6	0.9	14.8	ns
t <sub>PZL</sub>											

## Switching Characteristics

 over recommended operating free-air temperature range, V<sub>CCA</sub> = 2.5 V ± 0.2 V (unless otherwise noted) (see Figure 1)

PARAMETER	FROM (INPUT)	TO (OUTPUT)	V <sub>CCB</sub> = 1.8 V ± 0.15 V		V <sub>CCB</sub> = 2.5 V ± 0.2 V		V <sub>CCB</sub> = 3.3 V ± 0.3 V		V <sub>CCB</sub> = 5 V ± 0.5 V		UNIT
			MIN	MAX	MIN	MAX	MIN	MAX	MIN	MAX	
t <sub>PLH</sub>	A	B	1.5	25.4	1.2	13	0.8	10.2	0.6	8.8	ns
t <sub>PHL</sub>											
t <sub>PLH</sub>	B	A	1.2	13.3	1	13.1	1	12.9	0.9	12.8	ns
t <sub>PHL</sub>											
t <sub>PHZ</sub>	$\overline{OE}$	A	1.4	13	1.4	13	1.4	13	1.4	13	ns
t <sub>PLZ</sub>											
t <sub>PHZ</sub>	$\overline{OE}$	B	2.3	33.6	1.8	14	1.7	14.3	0.9	10.9	ns
t <sub>PLZ</sub>											
t <sub>PZH</sub>	$\overline{OE}$	A	1	14.9	1	14.9	1	14.9	1	14.9	ns
t <sub>PZL</sub>											
t <sub>PZH</sub>	$\overline{OE}$	B	1.7	32.2	1.5	16.9	1.2	13.4	1	10.9	ns
t <sub>PZL</sub>											

## Switching Characteristics

over recommended operating free-air temperature range,  $V_{CCA} = 3.3 \text{ V} \pm 0.3 \text{ V}$  (unless otherwise noted) (see Figure 1)

PARAMETER	FROM (INPUT)	TO (OUTPUT)	$V_{CCB} = 1.8 \text{ V} \pm 0.15 \text{ V}$		$V_{CCB} = 2.5 \text{ V} \pm 0.2 \text{ V}$		$V_{CCB} = 3.3 \text{ V} \pm 0.3 \text{ V}$		$V_{CCB} = 5 \text{ V} \pm 0.5 \text{ V}$		UNIT
			MIN	MAX	MIN	MAX	MIN	MAX	MIN	MAX	
$t_{PLH}$	A	B	1.6	25.2	1.1	12.8	0.8	10.2	0.6	8.4	ns
$t_{PHL}$											
$t_{PLH}$	B	A	0.8	11.2	0.8	10.2	0.7	10.1	0.6	10	ns
$t_{PHL}$											
$t_{PHZ}$	$\overline{OE}$	A	1.6	12.2	1.6	12.2	1.6	12.2	1.6	12.2	ns
$t_{PLZ}$											
$t_{PHZ}$	$\overline{OE}$	B	2.1	33	1.7	14.3	1.5	12.8	0.8	10.3	ns
$t_{PLZ}$											
$t_{PZH}$	$\overline{OE}$	A	0.8	11.8	0.8	12.1	0.8	12.1	0.8	12.1	ns
$t_{PZL}$											
$t_{PZH}$	$\overline{OE}$	B	1.8	3.7	1.4	16.4	1.1	12.5	0.8	10.4	ns
$t_{PZL}$											

## Switching Characteristics

over recommended operating free-air temperature range,  $V_{CCA} = 5 \text{ V} \pm 0.5 \text{ V}$  (unless otherwise noted) (see Figure 1)

PARAMETER	FROM (INPUT)	TO (OUTPUT)	$V_{CC} = 1.8 \text{ V} \pm 0.15 \text{ V}$		$V_{CC} = 2.5 \text{ V} \pm 0.2 \text{ V}$		$V_{CC} = 3.3 \text{ V} \pm 0.3 \text{ V}$		$V_{CC} = 5 \text{ V} \pm 0.5 \text{ V}$		UNIT
			MIN	MAX	MIN	MAX	MIN	MAX	MIN	MAX	
$t_{PLH}$	A	B	1.5	25.4	1	12.8	0.7	10	0.4	8.2	ns
$t_{PHL}$											
$t_{PLH}$	B	A	0.7	11	0.4	8.8	0.3	8.5	0.3	8.3	ns
$t_{PHL}$											
$t_{PHZ}$	$\overline{OE}$	A	0.3	9.4	0.3	9.4	0.3	9.4	0.3	9.4	ns
$t_{PLZ}$											
$t_{PHZ}$	$\overline{OE}$	B	2	32.7	1.8	13.7	1.4	12	0.7	9.7	ns
$t_{PLZ}$											
$t_{PZH}$	$\overline{OE}$	A	0.7	10.4	0.7	10.4	0.7	10.4	0.7	10.4	ns
$t_{PZL}$											
$t_{PZH}$	$\overline{OE}$	B	1.5	31.6	1.3	15.4	1	12.1	0.9	10	ns
$t_{PZL}$											

## Operating Characteristics

$T_A = 25 = C$

PARAMETER		TEST CONDITIONS	$V_{CCA} =$ $V_{CCB} = 1.8 \text{ V}$	$V_{CCA} =$ $V_{CCB} = 2.5 \text{ V}$	$V_{CCA} =$ $V_{CCB} = 3.3 \text{ V}$	$V_{CCA} =$ $V_{CCB} = 5 \text{ V}$	UNIT
			TYP	TYP	TYP	TYP	
$C_{pdA}^{(1)}$	A-port input, B-port output	$C_L = 0,$ $f = 10 \text{ MHz},$ $t_r = t_f = 1 \text{ ns}$	2	2	2	3	pF
	B-port input, A-port output		18	19	19	22	
$C_{pdB}^{(1)}$	A-port input, B-port output		18	19	20	22	
	B-port input, A-port output		2	2	2	2	

(1) Power dissipation capacitance per transceiver

PARAMETER MEASUREMENT INFORMATION

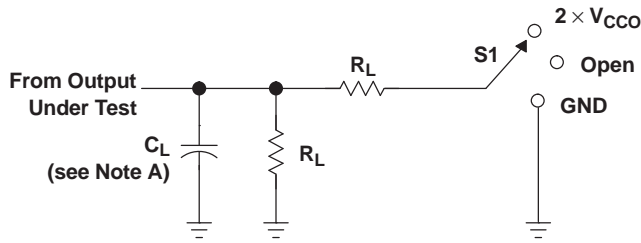

LOAD CIRCUIT

TEST	S1
$t_{pd}$	Open
$t_{PLZ}/t_{PZL}$	$2 \times V_{CCO}$
$t_{PHZ}/t_{PZH}$	GND

$V_{CCO}$	$C_L$	$R_L$	$V_{TP}$
$1.8\text{ V} \pm 0.15\text{ V}$	15 pF	2 k $\Omega$	0.15 V
$2.5\text{ V} \pm 0.2\text{ V}$	15 pF	2 k $\Omega$	0.15 V
$3.3\text{ V} \pm 0.3\text{ V}$	15 pF	2 k $\Omega$	0.3 V
$5\text{ V} \pm 0.5\text{ V}$	15 pF	2 k $\Omega$	0.3 V

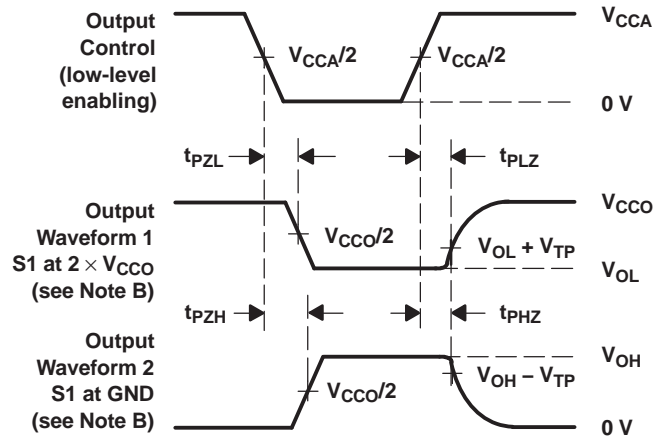
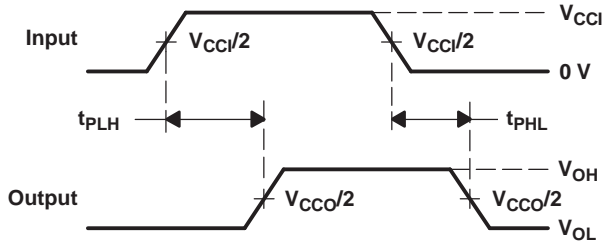
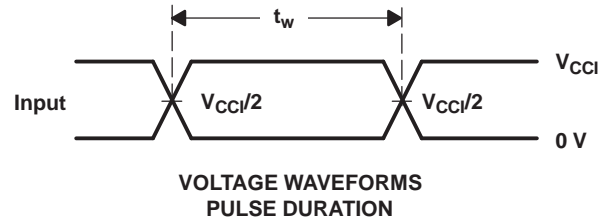

- NOTES:
- A.  $C_L$  includes probe and jig capacitance.
  - B. Waveform 1 is for an output with internal conditions such that the output is low, except when disabled by the output control. Waveform 2 is for an output with internal conditions such that the output is high, except when disabled by the output control.
  - C. All input pulses are supplied by generators having the following characteristics:  $PRR \leq 10\text{ MHz}$ ,  $Z_O = 50\ \Omega$ ,  $dv/dt \geq 1\text{ V/ns}$ ,  $dv/dt \geq 1\text{ V/ns}$ .
  - D. The outputs are measured one at a time, with one transition per measurement.
  - E.  $t_{PLZ}$  and  $t_{PHZ}$  are the same as  $t_{dis}$ .
  - F.  $t_{PZL}$  and  $t_{PZH}$  are the same as  $t_{en}$ .
  - G.  $t_{PLH}$  and  $t_{PHL}$  are the same as  $t_{pd}$ .
  - H.  $V_{CCi}$  is the  $V_{CC}$  associated with the input port.
  - I.  $V_{CCo}$  is the  $V_{CC}$  associated with the output port.
  - J. All parameters and waveforms are not applicable to all devices.

Figure 1. Load Circuit and Voltage Waveforms

**PACKAGING INFORMATION**

Orderable Device	Status <sup>(1)</sup>	Package Type	Package Drawing	Pins	Package Qty	Eco Plan <sup>(2)</sup>	Lead/Ball Finish	MSL Peak Temp <sup>(3)</sup>
CLVCH16T245MDGGREP	ACTIVE	TSSOP	DGG	48	2000	Green (RoHS & no Sb/Br)	CU NIPDAU	Level-1-260C-UNLIM
CLVCH16T245MDGVREP	ACTIVE	TVSOP	DGV	48	2000	Green (RoHS & no Sb/Br)	CU NIPDAU	Level-1-260C-UNLIM
V62/09605-01XE	ACTIVE	TSSOP	DGG	48	2000	Green (RoHS & no Sb/Br)	CU NIPDAU	Level-1-260C-UNLIM
V62/09605-01YE	ACTIVE	TVSOP	DGV	48	2000	Green (RoHS & no Sb/Br)	CU NIPDAU	Level-1-260C-UNLIM

<sup>(1)</sup> The marketing status values are defined as follows:

**ACTIVE:** Product device recommended for new designs.

**LIFEBUY:** TI has announced that the device will be discontinued, and a lifetime-buy period is in effect.

**NRND:** Not recommended for new designs. Device is in production to support existing customers, but TI does not recommend using this part in a new design.

**PREVIEW:** Device has been announced but is not in production. Samples may or may not be available.

**OBSOLETE:** TI has discontinued the production of the device.

<sup>(2)</sup> Eco Plan - The planned eco-friendly classification: Pb-Free (RoHS), Pb-Free (RoHS Exempt), or Green (RoHS & no Sb/Br) - please check <http://www.ti.com/productcontent> for the latest availability information and additional product content details.

**TBD:** The Pb-Free/Green conversion plan has not been defined.

**Pb-Free (RoHS):** TI's terms "Lead-Free" or "Pb-Free" mean semiconductor products that are compatible with the current RoHS requirements for all 6 substances, including the requirement that lead not exceed 0.1% by weight in homogeneous materials. Where designed to be soldered at high temperatures, TI Pb-Free products are suitable for use in specified lead-free processes.

**Pb-Free (RoHS Exempt):** This component has a RoHS exemption for either 1) lead-based flip-chip solder bumps used between the die and package, or 2) lead-based die adhesive used between the die and leadframe. The component is otherwise considered Pb-Free (RoHS compatible) as defined above.

**Green (RoHS & no Sb/Br):** TI defines "Green" to mean Pb-Free (RoHS compatible), and free of Bromine (Br) and Antimony (Sb) based flame retardants (Br or Sb do not exceed 0.1% by weight in homogeneous material)

<sup>(3)</sup> MSL, Peak Temp. -- The Moisture Sensitivity Level rating according to the JEDEC industry standard classifications, and peak solder temperature.

**Important Information and Disclaimer:** The information provided on this page represents TI's knowledge and belief as of the date that it is provided. TI bases its knowledge and belief on information provided by third parties, and makes no representation or warranty as to the accuracy of such information. Efforts are underway to better integrate information from third parties. TI has taken and continues to take reasonable steps to provide representative and accurate information but may not have conducted destructive testing or chemical analysis on incoming materials and chemicals. TI and TI suppliers consider certain information to be proprietary, and thus CAS numbers and other limited information may not be available for release.

In no event shall TI's liability arising out of such information exceed the total purchase price of the TI part(s) at issue in this document sold by TI to Customer on an annual basis.

**OTHER QUALIFIED VERSIONS OF SN74LVCH16T245-EP :**

- Catalog: [SN74LVCH16T245](#)

NOTE: Qualified Version Definitions:

- Catalog - TI's standard catalog product

TAPE AND REEL INFORMATION

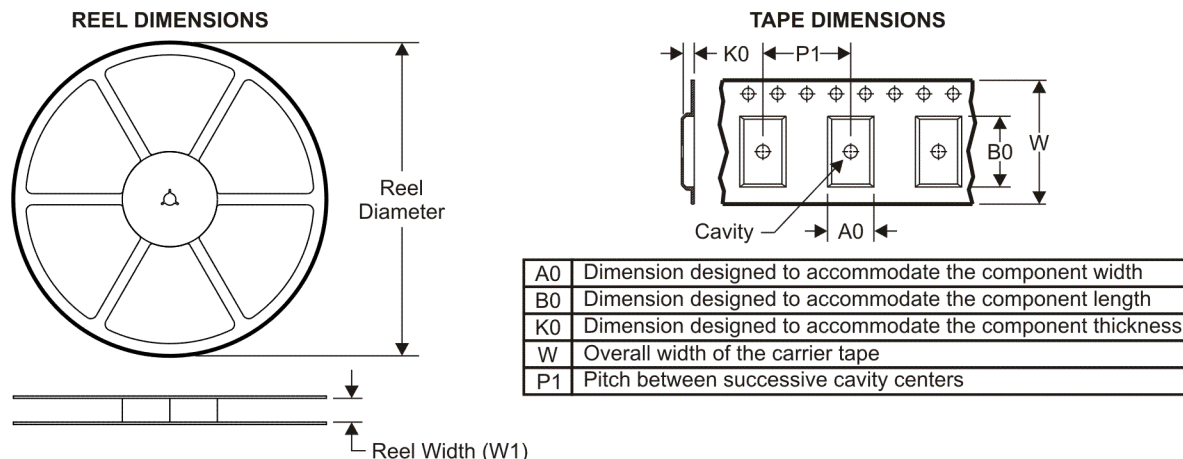

QUADRANT ASSIGNMENTS FOR PIN 1 ORIENTATION IN TAPE

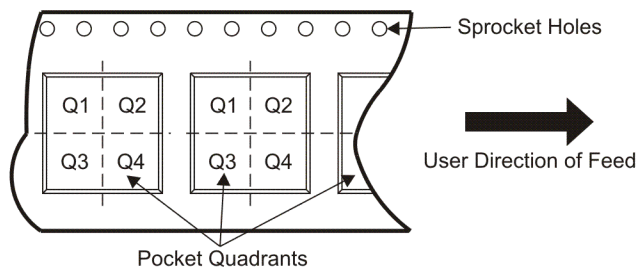

\*All dimensions are nominal

Device	Package Type	Package Drawing	Pins	SPQ	Reel Diameter (mm)	Reel Width W1 (mm)	A0 (mm)	B0 (mm)	K0 (mm)	P1 (mm)	W (mm)	Pin1 Quadrant
CLVCH16T245MDGGREP	TSSOP	DGG	48	2000	330.0	24.4	8.6	15.8	1.8	12.0	24.0	Q1
CLVCH16T245MDGVREP	TVSOP	DGV	48	2000	330.0	16.4	7.1	10.2	1.6	12.0	16.0	Q1

**TAPE AND REEL BOX DIMENSIONS**



\*All dimensions are nominal

Device	Package Type	Package Drawing	Pins	SPQ	Length (mm)	Width (mm)	Height (mm)
CLVCH16T245MDGGREP	TSSOP	DGG	48	2000	346.0	346.0	41.0
CLVCH16T245MDGVREP	TVSOP	DGV	48	2000	346.0	346.0	33.0

DGG (R-PDSO-G\*\*)

PLASTIC SMALL-OUTLINE PACKAGE

48 PINS SHOWN

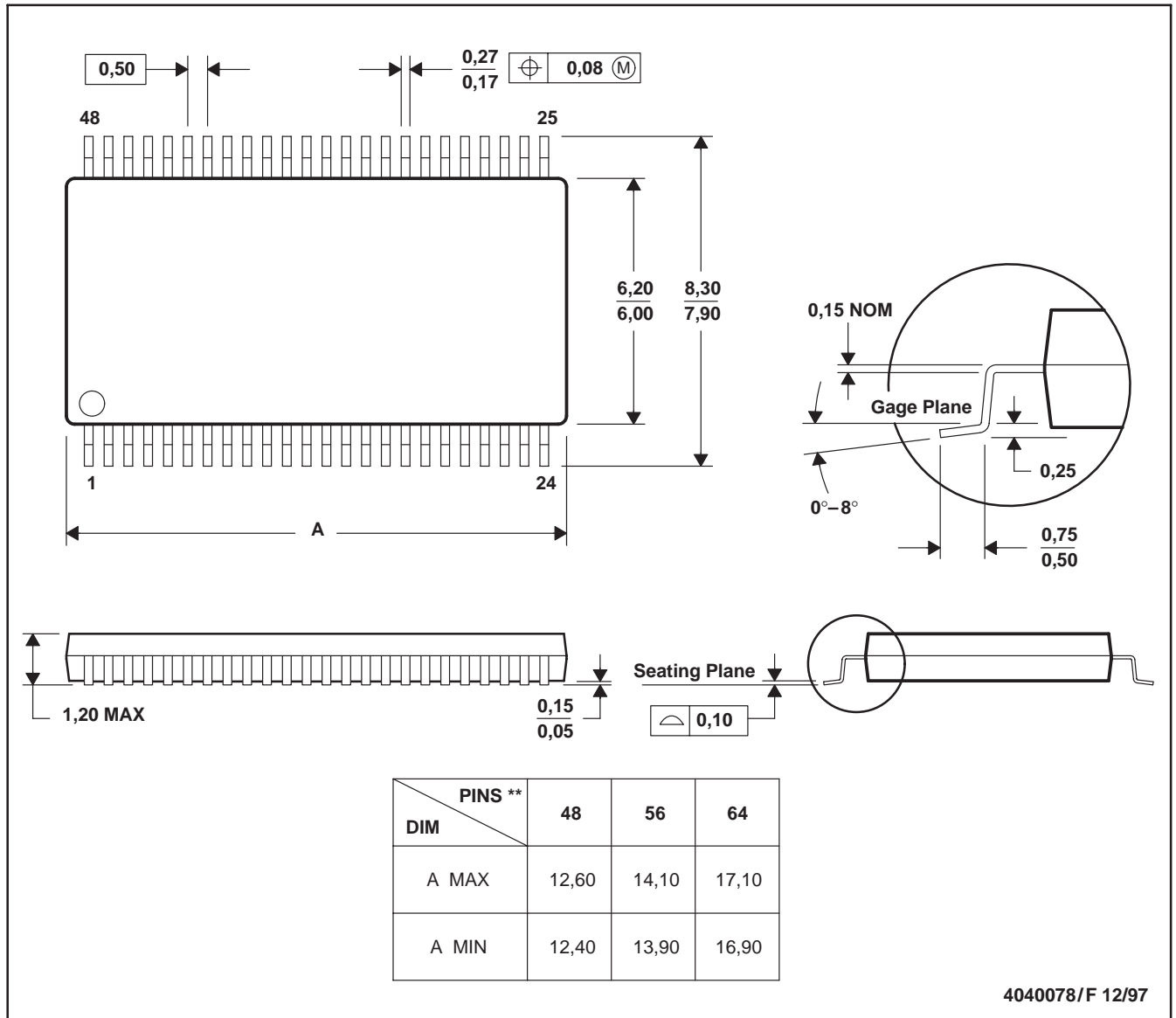

- NOTES: A. All linear dimensions are in millimeters.  
 B. This drawing is subject to change without notice.  
 C. Body dimensions do not include mold protrusion not to exceed 0,15.  
 D. Falls within JEDEC MO-153

## IMPORTANT NOTICE

Texas Instruments Incorporated and its subsidiaries (TI) reserve the right to make corrections, modifications, enhancements, improvements, and other changes to its products and services at any time and to discontinue any product or service without notice. Customers should obtain the latest relevant information before placing orders and should verify that such information is current and complete. All products are sold subject to TI's terms and conditions of sale supplied at the time of order acknowledgment.

TI warrants performance of its hardware products to the specifications applicable at the time of sale in accordance with TI's standard warranty. Testing and other quality control techniques are used to the extent TI deems necessary to support this warranty. Except where mandated by government requirements, testing of all parameters of each product is not necessarily performed.

TI assumes no liability for applications assistance or customer product design. Customers are responsible for their products and applications using TI components. To minimize the risks associated with customer products and applications, customers should provide adequate design and operating safeguards.

TI does not warrant or represent that any license, either express or implied, is granted under any TI patent right, copyright, mask work right, or other TI intellectual property right relating to any combination, machine, or process in which TI products or services are used. Information published by TI regarding third-party products or services does not constitute a license from TI to use such products or services or a warranty or endorsement thereof. Use of such information may require a license from a third party under the patents or other intellectual property of the third party, or a license from TI under the patents or other intellectual property of TI.

Reproduction of TI information in TI data books or data sheets is permissible only if reproduction is without alteration and is accompanied by all associated warranties, conditions, limitations, and notices. Reproduction of this information with alteration is an unfair and deceptive business practice. TI is not responsible or liable for such altered documentation. Information of third parties may be subject to additional restrictions.

Resale of TI products or services with statements different from or beyond the parameters stated by TI for that product or service voids all express and any implied warranties for the associated TI product or service and is an unfair and deceptive business practice. TI is not responsible or liable for any such statements.

TI products are not authorized for use in safety-critical applications (such as life support) where a failure of the TI product would reasonably be expected to cause severe personal injury or death, unless officers of the parties have executed an agreement specifically governing such use. Buyers represent that they have all necessary expertise in the safety and regulatory ramifications of their applications, and acknowledge and agree that they are solely responsible for all legal, regulatory and safety-related requirements concerning their products and any use of TI products in such safety-critical applications, notwithstanding any applications-related information or support that may be provided by TI. Further, Buyers must fully indemnify TI and its representatives against any damages arising out of the use of TI products in such safety-critical applications.

TI products are neither designed nor intended for use in military/aerospace applications or environments unless the TI products are specifically designated by TI as military-grade or "enhanced plastic." Only products designated by TI as military-grade meet military specifications. Buyers acknowledge and agree that any such use of TI products which TI has not designated as military-grade is solely at the Buyer's risk, and that they are solely responsible for compliance with all legal and regulatory requirements in connection with such use.

TI products are neither designed nor intended for use in automotive applications or environments unless the specific TI products are designated by TI as compliant with ISO/TS 16949 requirements. Buyers acknowledge and agree that, if they use any non-designated products in automotive applications, TI will not be responsible for any failure to meet such requirements.

Following are URLs where you can obtain information on other Texas Instruments products and application solutions:

### Products

Amplifiers	<a href="http://amplifier.ti.com">amplifier.ti.com</a>
Data Converters	<a href="http://dataconverter.ti.com">dataconverter.ti.com</a>
DLP® Products	<a href="http://www.dlp.com">www.dlp.com</a>
DSP	<a href="http://dsp.ti.com">dsp.ti.com</a>
Clocks and Timers	<a href="http://www.ti.com/clocks">www.ti.com/clocks</a>
Interface	<a href="http://interface.ti.com">interface.ti.com</a>
Logic	<a href="http://logic.ti.com">logic.ti.com</a>
Power Mgmt	<a href="http://power.ti.com">power.ti.com</a>
Microcontrollers	<a href="http://microcontroller.ti.com">microcontroller.ti.com</a>
RFID	<a href="http://www.ti-rfid.com">www.ti-rfid.com</a>
RF/IF and ZigBee® Solutions	<a href="http://www.ti.com/lprf">www.ti.com/lprf</a>

### Applications

Audio	<a href="http://www.ti.com/audio">www.ti.com/audio</a>
Automotive	<a href="http://www.ti.com/automotive">www.ti.com/automotive</a>
Broadband	<a href="http://www.ti.com/broadband">www.ti.com/broadband</a>
Digital Control	<a href="http://www.ti.com/digitalcontrol">www.ti.com/digitalcontrol</a>
Medical	<a href="http://www.ti.com/medical">www.ti.com/medical</a>
Military	<a href="http://www.ti.com/military">www.ti.com/military</a>
Optical Networking	<a href="http://www.ti.com/opticalnetwork">www.ti.com/opticalnetwork</a>
Security	<a href="http://www.ti.com/security">www.ti.com/security</a>
Telephony	<a href="http://www.ti.com/telephony">www.ti.com/telephony</a>
Video & Imaging	<a href="http://www.ti.com/video">www.ti.com/video</a>
Wireless	<a href="http://www.ti.com/wireless">www.ti.com/wireless</a>