

# SN54174, SN54175, SN54LS174, SN54LS175, SN54S174, SN54S175, SN74174, SN74175, SN74LS174, SN74LS175, SN74S174, SN74S175 HEX/QUADRUPLE D-TYPE FLIP-FLOPS WITH CLEAR

SDLS068A – DECEMBER 1972 – REVISED OCTOBER 2001

查询"SN54LS174"供应商

'174, 'LS174, 'S174 ... HEX D-TYPE FLIP-FLOPS  
'175, 'LS175, 'S175 ... QUADRUPLE D-TYPE FLIP-FLOPS

- '174, 'LS174, 'S174 Contain Six Flip-Flops with Single-Rail Outputs
- '175, 'LS175, 'S175 Contain Four Flip-Flops with Double-Rail Outputs
- Three Performance Ranges Offered: See Table Lower Right
- Buffered Clock and Direct Clear Inputs
- Individual Data Input to Each Flip-Flop
- Applications include:  
Buffer/Storage Registers  
Shift Registers  
Pattern Generators

SN54174, SN54LS174, SN54S174 ... J OR W PACKAGE  
SN74174 ... N PACKAGE  
SN74LS174, SN74S174 ... D OR N PACKAGE

(TOP VIEW)

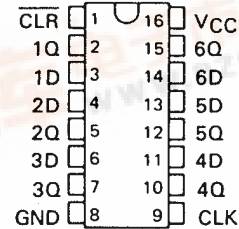

SN54LS174, SN54S174 ... FK PACKAGE

(TOP VIEW)

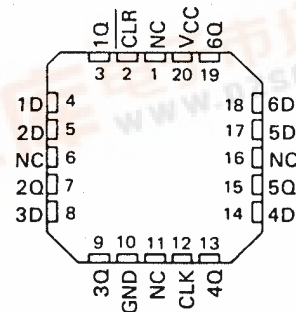

SN54175, SN54LS175, SN54S175 ... J OR W PACKAGE  
SN74175 ... N PACKAGE  
SN74LS175, SN74S175 ... D OR N PACKAGE

(TOP VIEW)

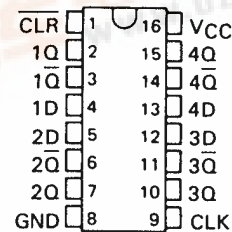

SN54LS175, SN54S175 ... FK PACKAGE

(TOP VIEW)

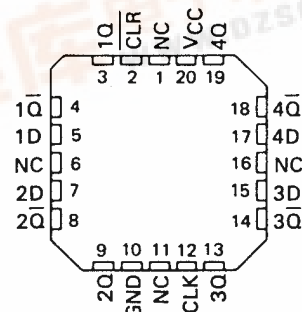

NC – No internal connection

## description

These monolithic, positive-edge-triggered flip-flops utilize TTL circuitry to implement D-type flip-flop logic. All have a direct clear input, and the '175, 'LS175, and 'S175 feature complementary outputs from each flip-flop.

Information at the D inputs meeting the setup time requirements is transferred to the Q outputs on the positive-going edge of the clock pulse. Clock triggering occurs at a particular voltage level and is not directly related to the transition time of the positive-going pulse. When the clock input is at either the high or low level, the D input signal has no effect at the output.

These circuits are fully compatible for use with most TTL circuits.

FUNCTION TABLE  
(EACH FLIP-FLOP)

INPUTS			OUTPUTS	
CLEAR	CLOCK	D	Q	Q̄†
L	X	X	L	H
H	↑	H	H	L
H	↑	L	L	H
H	L	X	Q <sub>0</sub>	Q̄ <sub>0</sub>

H = high level (steady state)

L = low level (steady state)

X = irrelevant

↑ = transition from low to high level

Q<sub>0</sub> = the level of Q before the indicated steady-state input conditions were established.

† = '175, 'LS175, and 'S175 only

TYPES	TYPICAL	TYPICAL
	MAXIMUM	POWER
	CLOCK	DISSIPATION
	FREQUENCY	PER FLIP-FLOP
'174, '175	35 MHz	38 mW
'LS174, 'LS175	40 MHz	14 mW
'S174, 'S175	110 MHz	75 mW

PRODUCTION DATA information is current as of publication date. Products conform to specifications per the terms of Texas Instruments standard warranty. Production processing does not necessarily include testing of all parameters.

TEXAS  
INSTRUMENTS

POST OFFICE BOX 655303 • DALLAS, TEXAS 75265

Copyright © 2001, Texas Instruments Incorporated



# SN54174, SN54175, SN54LS174, SN54LS175, SN54S174, SN54S175, SN74174, SN74175, SN74LS174, SN74LS175, SN74S174, SN74S175 HEX/QUADRUPLE D-TYPE FLIP-FLOPS WITH CLEAR

SDLS059 REVISED NOVEMBER 1972 (REVISED) OCTOBER 2001

## logic symbols†

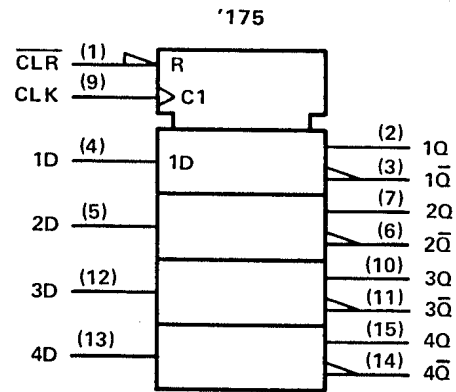
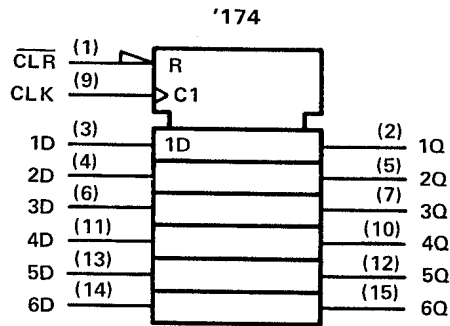

†These symbols are in accordance with ANSI/IEEE Std. 91-1984 and IEC Publication 617-12. Pin numbers shown are for D, J, N, and W packages.

## logic diagrams (positive logic)

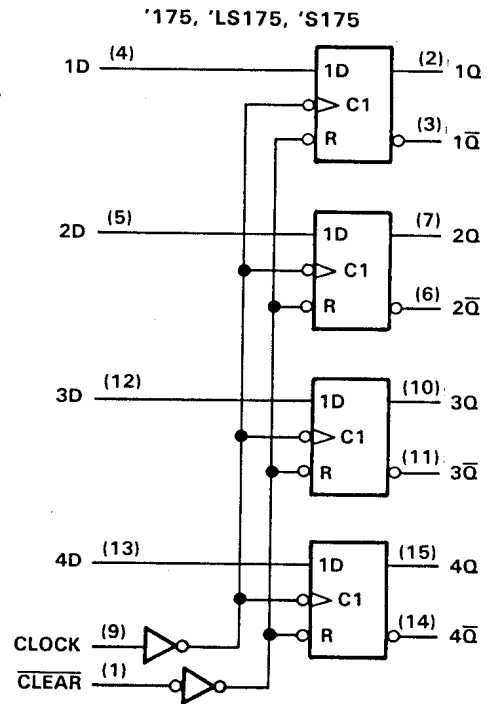
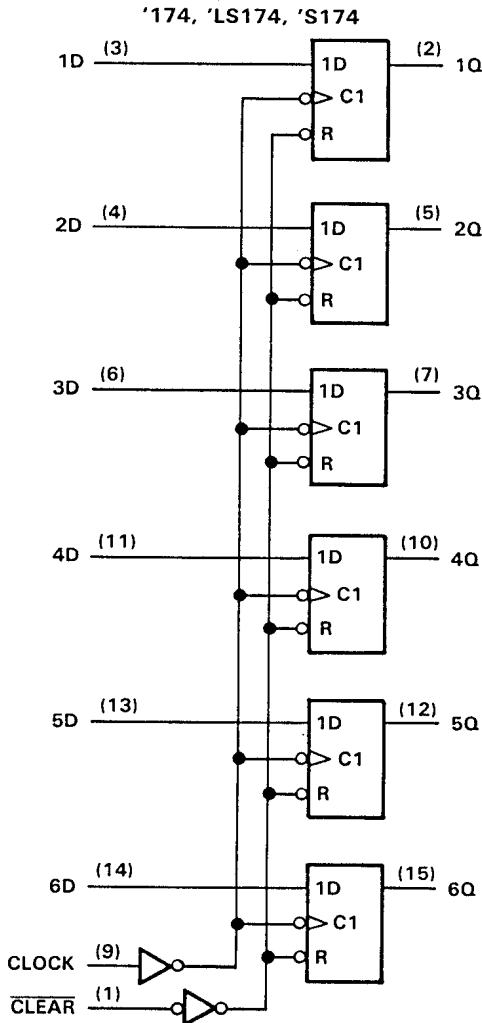

Pin numbers shown are for D, J, N, and W packages.



POST OFFICE BOX 655303 • DALLAS, TEXAS 75265

SN54174, SN54175, SN54LS174, SN54LS175, SN54S174, SN54S175,  
 SN74174, SN74175, SN74LS174, SN74LS175, SN74S174, SN74S175  
 HEX/QUADRUPLE D-TYPE FLIP-FLOPS WITH CLEAR

SDLS068A - DECEMBER 1972 - REVISED OCTOBER 2001

[查询"SN54LS174"供应商](#)

schematics of inputs and outputs

SN54174, SN54175, SN74174, SN74175

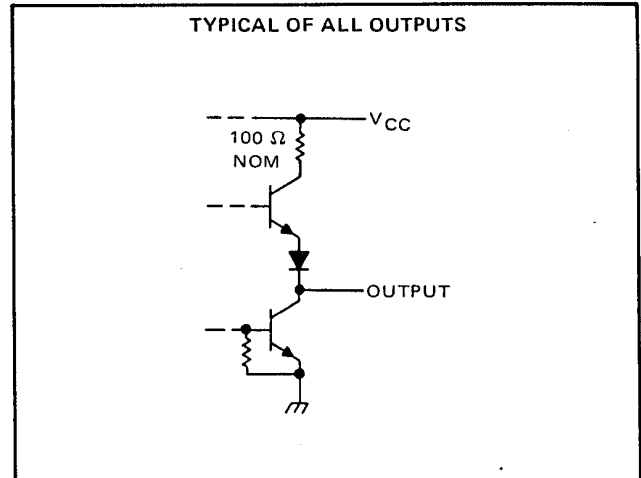
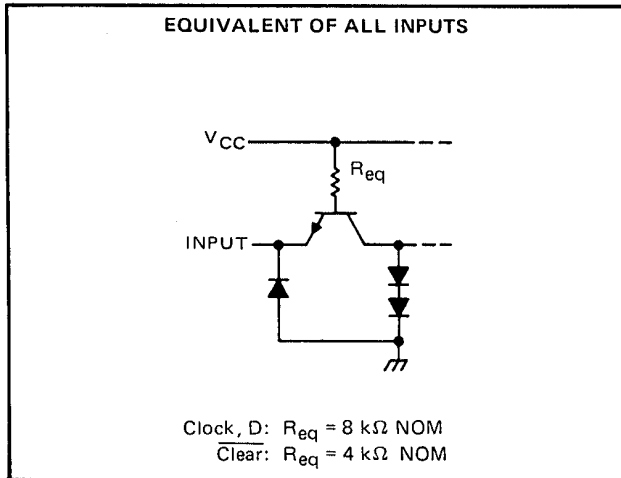

SN54LS174, SN54LS175, SN74LS174, SN74LS175

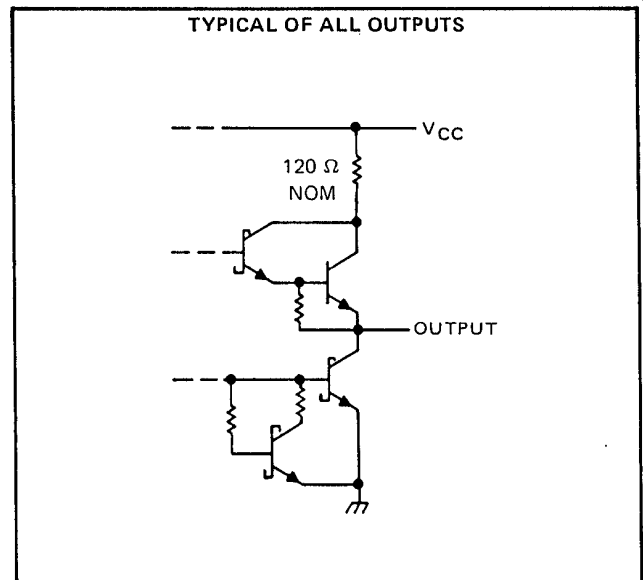
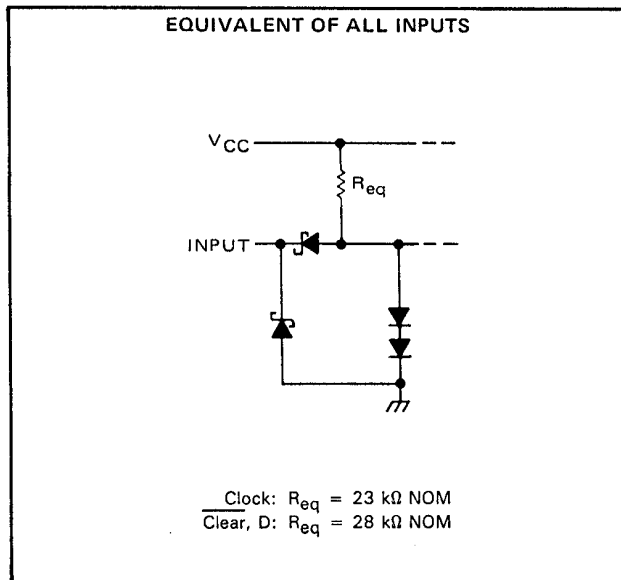

SN54S174, SN54S175, SN74S174, SN74S175

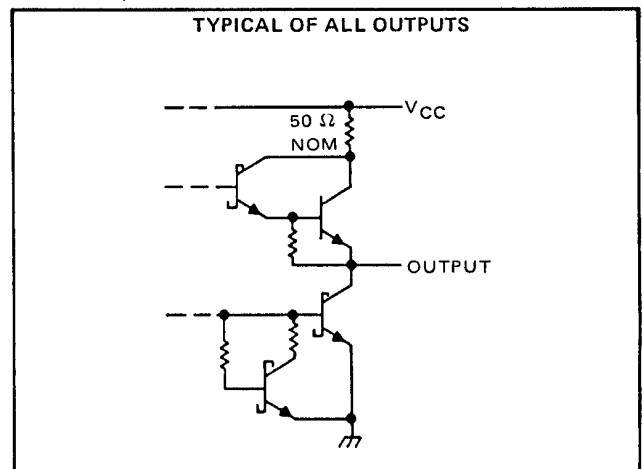
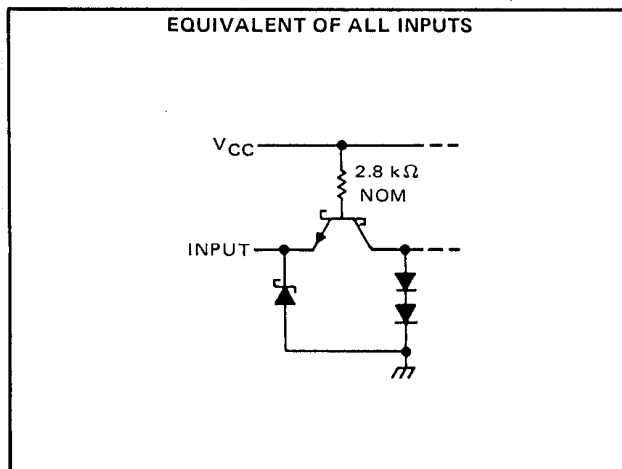

# SN54174, SN54175, SN74174, SN74175 HEX/QUADRUPLE D-TYPE FLIP-FLOPS WITH CLEAR

SDLS059A 1989 NOVEMBER 1974 REVISIONS OCTOBER 2001

查询 SN54174 供应商

**absolute maximum ratings over operating free-air temperature range (unless otherwise noted)**

Supply voltage, V <sub>CC</sub> (see Note 1)	7 V
Input voltage	5.5 V
Operating free-air temperature range: SN54174, SN54175 Circuits	-55°C to 125°C
SN74174, SN74175 Circuits	0°C to 70°C
Storage temperature range	-65°C to 150°C

NOTE 1: Voltage values are with respect to network ground terminal.

**recommended operating conditions**

	SN54174, SN54175			SN74174, SN74175			UNIT
	MIN	NOM	MAX	MIN	NOM	MAX	
Supply voltage, V <sub>CC</sub>	4.5	5	5.5	4.75	5	5.25	V
High-level output current, I <sub>OH</sub>			-800			-800	μA
Low-level output current, I <sub>OL</sub>			16			16	mA
Clock frequency, f <sub>clock</sub>	0		25	0		25	MHz
Width of clock or clear pulse, t <sub>w</sub>	20			20			ns
Setup time, t <sub>su</sub>	Data input			20			ns
	Clear inactive-state			25			ns
Data hold time, t <sub>h</sub>	5			5			ns
Operating free-air temperature, T <sub>A</sub>	-55		125	0		70	°C

**electrical characteristics over recommended operating free-air temperature range (unless otherwise noted)**

PARAMETER	TEST CONDITIONS†	MIN	TYP‡	MAX	UNIT
V <sub>IH</sub> High-level input voltage		2			V
V <sub>IL</sub> Low-level input voltage				0.8	V
V <sub>IK</sub> Input clamp voltage	V <sub>CC</sub> = MIN, I <sub>I</sub> = -12 mA			-1.5	V
V <sub>OH</sub> High-level output voltage	V <sub>CC</sub> = MIN, V <sub>IH</sub> = 2 V, V <sub>IL</sub> = 0.8 V, I <sub>OH</sub> = -800 μA	2.4	3.4		V
V <sub>OL</sub> Low-level output voltage	V <sub>CC</sub> = MIN, V <sub>IH</sub> = 2 V, V <sub>IL</sub> = 0.8 V, I <sub>OL</sub> = 16 mA		0.2	0.4	V
I <sub>I</sub> Input current at maximum input voltage	V <sub>CC</sub> = MAX, V <sub>I</sub> = 5.5 V			1	mA
I <sub>IH</sub> High-level input current	V <sub>CC</sub> = MAX, V <sub>I</sub> = 2.4 V			40	μA
I <sub>IL</sub> Low-level input current	V <sub>CC</sub> = MAX, V <sub>I</sub> = 0.4 V			-1.6	mA
I <sub>OS</sub> Short-circuit output current §	V <sub>CC</sub> = MAX	SN54'	-20	-57	mA
		SN74'	-18	-57	
I <sub>CC</sub> Supply current	V <sub>CC</sub> = MAX, See Note 2	'174	45	65	mA
		'175	30	45	

† For conditions shown as MIN or MAX, use the appropriate value specified under recommended operating conditions for the applicable device type.

‡ All typical values are at V<sub>CC</sub> = 5 V, T<sub>A</sub> = 25°C.

§ Not more than one output should be shorted at a time.

NOTE 2: With all outputs open and 4.5 V applied to all data and clear inputs, I<sub>CC</sub> is measured after a momentary ground, then 4.5 V, is applied to clock.

**switching characteristics, V<sub>CC</sub> = 5 V, T<sub>A</sub> = 25°C**

PARAMETER	TEST CONDITIONS	MIN	TYP	MAX	UNIT
f <sub>max</sub> Maximum clock frequency		25	35		MHz
t <sub>PLH</sub> Propagation delay time, low-to-high-level output from clear (SN54175, SN74175 only)	C <sub>L</sub> = 15 pF, R <sub>L</sub> = 400 Ω, See Note 3		16	25	ns
t <sub>PHL</sub> Propagation delay time, high-to-low-level output from clear			23	35	ns
t <sub>PLH</sub> Propagation delay time, low-to-high-level output from clock			20	30	ns
t <sub>PHL</sub> Propagation delay time, high-to-low-level output from clock			24	35	ns

NOTE 3: Load circuits and voltage waveforms are shown in Section 1.



# SN54LS174, SN54LS175, SN74LS174, SN74LS175 HEX/QUADRUPLE D-TYPE FLIP-FLOPS WITH CLEAR

查询"SN54LS174"供应商

SDLS068A – DECEMBER 1972 – REVISED OCTOBER 2001

**absolute maximum ratings over operating free-air temperature range (unless otherwise noted)**

Supply voltage, $V_{CC}$ (see Note 1)	7 V
Input voltage	7 V
Operating free-air temperature range: SN54LS174, SN54LS175 Circuits	-55°C to 125°C
SN74LS174, SN74LS175 Circuits	0°C to 70°C
Storage temperature range	-65°C to 150°C

NOTE 1: Voltage values are with respect to network ground terminal.

**recommended operating conditions**

	SN54LS174			SN74LS174			UNIT
	SN54LS175			SN74LS175			
	MIN	NOM	MAX	MIN	NOM	MAX	
Supply voltage, $V_{CC}$	4.5	5	5.5	4.75	5	5.25	V
High-level output current, $I_{OH}$			-400			-400	$\mu$ A
Low-level output current, $I_{OL}$			4			8	mA
Clock frequency, $f_{clock}$	0		30	0		30	MHz
Width of clock or clear pulse, $t_W$	20			20			ns
Setup time, $t_{su}$	Data input			20			ns
	Clear inactive-state			25			ns
Data hold time, $t_h$	5			5			ns
Operating free-air temperature, $T_A$	-55		125	0		70	°C

**electrical characteristics over recommended operating free-air temperature range (unless otherwise noted)**

PARAMETER	TEST CONDITIONS†	SN54LS174			SN74LS174			UNIT
		SN54LS175			SN74LS175			
		MIN	TYP‡	MAX	MIN	TYP‡	MAX	
$V_{IH}$ High-level input voltage		2			2			V
$V_{IL}$ Low-level input voltage			0.7			0.8		V
$V_{IK}$ Input clamp voltage	$V_{CC} = \text{MIN}, I_I = -18 \text{ mA}$		-1.5			-1.5		V
$V_{OH}$ High-level output voltage	$V_{CC} = \text{MIN}, V_{IH} = 2 \text{ V}, V_{IL} = V_{IL \text{ max}}, I_{OH} = -400 \mu\text{A}$	2.5	3.5		2.7	3.5		V
$V_{OL}$ Low-level output voltage	$V_{CC} = \text{MIN}, V_{IH} = 2 \text{ V}, V_{IL} = V_{IL \text{ max}}$	$I_{OL} = 4 \text{ mA}$		0.25	0.4	0.25	0.4	V
		$I_{OL} = 8 \text{ mA}$				0.35	0.5	
$I_I$ Input current at maximum input voltage	$V_{CC} = \text{MAX}, V_I = 7 \text{ V}$		0.1			0.1	mA	
$I_{IH}$ High-level input current	$V_{CC} = \text{MAX}, V_I = 2.7 \text{ V}$			20		20	$\mu$ A	
$I_{IL}$ Low-level input current	$V_{CC} = \text{MAX}, V_I = 0.4 \text{ V}$			-0.4		-0.4	mA	
$I_{OS}$ Short-circuit output current §	$V_{CC} = \text{MAX}$	-20		-100	-20		-100	mA
$I_{CC}$ Supply current	$V_{CC} = \text{MAX},$ See Note 2	'LS174		16	26	16	26	mA
		'LS175		11	18	11	18	

† For conditions shown as MIN or MAX, use the appropriate value specified under recommended operating conditions.

‡ All typical values are at  $V_{CC} = 5 \text{ V}, T_A = 25^\circ\text{C}$ .

§ Not more than one output should be shorted at a time, and duration of the short-circuit should not exceed one second.

NOTE 2: With all outputs open and 4.5 V applied to all data and clear inputs,  $I_{CC}$  is measured after a momentary ground, then 4.5 V, is applied to clock.

**switching characteristics,  $V_{CC} = 5 \text{ V}, T_A = 25^\circ\text{C}$**

PARAMETER	TEST CONDITIONS	'LS174			'LS175			UNIT
		MIN	TYP	MAX	MIN	TYP	MAX	
$f_{max}$ Maximum clock frequency	$C_L = 15 \text{ pF},$ $R_L = 2 \text{ k}\Omega,$ See Note 3	30	40		30	40		MHz
$t_{PLH}$ Propagation delay time, low-to-high-level output from clear					20	30		ns
$t_{PHL}$ Propagation delay time, high-to-low-level output from clear			23	35	20	30		ns
$t_{PLH}$ Propagation delay time, low-to-high-level output from clock			20	30	13	25		ns
$t_{PHL}$ Propagation delay time, high-to-low-level output from clock			21	30	16	25		ns

NOTE 3: Load circuits and voltage waveforms are shown in Section 1.



# SN54S174, SN54S175, SN74S174, SN74S175 HEX/QUADRUPLE D-TYPE FLIP-FLOPS WITH CLEAR

SDLS059 查询 SN54S174 供应商 OCTOBER 2001

## absolute maximum ratings over operating free-air temperature range (unless otherwise noted)

Supply voltage, $V_{CC}$ (see Note 1)	7 V
Input voltage	5.5 V
Operating free-air temperature range: SN54S174, SN54S175 Circuits	-55°C to 125°C
SN74S174, SN74S175 Circuits	0°C to 70°C
Storage temperature range	-65°C to 150°C

NOTE 1: Voltage values are with respect to network ground terminal.

## recommended operating conditions

	SN54S174, SN54S175			SN74S174, SN74S175			UNIT
	MIN	NOM	MAX	MIN	NOM	MAX	
Supply voltage, $V_{CC}$	4.5	5	5.5	4.75	5	5.25	V
High-level output current, $I_{OH}$			-1			-1	mA
Low-level output current, $I_{OL}$			20			20	mA
Clock frequency, $f_{clock}$	0		75	0		75	MHz
Pulse width, $t_w$	Clock		7			7	ns
	Clear		10			10	
Setup time, $t_{su}$	Data input		5			5	ns
	Clear inactive-state		5			5	
Data hold time, $t_h$			3			3	ns
Operating free-air temperature, $T_A$	-55		125	0		70	°C

## electrical characteristics over recommended operating free-air temperature range (unless otherwise noted)

PARAMETER	TEST CONDITIONS†	MIN	TYP‡	MAX	UNIT
$V_{IH}$ High-level input voltage		2			V
$V_{IL}$ Low-level input voltage				0.8	V
$V_{IK}$ Input clamp voltage	$V_{CC} = \text{MIN}, I_I = -18 \text{ mA}$			-1.2	V
$V_{OH}$ High-level output voltage	$V_{CC} = \text{MIN}, V_{IH} = 2 \text{ V},$ $V_{IL} = 0.8 \text{ V}, I_{OH} = -1 \text{ mA}$	SN54S'	2.5	3.4	V
		SN74S'	2.7	3.4	
$V_{OL}$ Low-level output voltage	$V_{CC} = \text{MIN}, V_{IH} = 2 \text{ V},$ $V_{IL} = 0.8 \text{ V}, I_{OL} = 20 \text{ mA}$			0.5	V
$I_I$ Input current at maximum input voltage	$V_{CC} = \text{MAX}, V_I = 5.5 \text{ V}$			1	mA
$I_{IH}$ High-level input current	$V_{CC} = \text{MAX}, V_I = 2.7 \text{ V}$			50	μA
$I_{IL}$ Low-level input current	$V_{CC} = \text{MAX}, V_I = 0.5 \text{ V}$			-2	mA
$I_{OS}$ Short-circuit output current §	$V_{CC} = \text{MAX}$	-40		-100	mA
$I_{CC}$ Supply current	$V_{CC} = \text{MAX}, \text{ See Note 2}$	'174	90	144	mA
		'175	60	96	

† For conditions shown as MIN or MAX, use the appropriate value specified under recommended operating conditions for the applicable device type.

‡ All typical values are at  $V_{CC} = 5 \text{ V}, T_A = 25^\circ\text{C}$ .

§ Not more than one output should be shorted at a time, and duration of the short-circuit should not exceed one second.

NOTE 2: With all outputs open and 4.5 V applied to all data and clear inputs,  $I_{CC}$  is measured after a momentary ground, then 4.5 V, is applied to clock.

## switching characteristics, $V_{CC} = 5 \text{ V}, T_A = 25^\circ\text{C}$

PARAMETER	TEST CONDITIONS	MIN	TYP	MAX	UNIT
$f_{max}$ Maximum clock frequency		75	110		MHz
$t_{PLH}$ Propagation delay time, low-to-high-level $\bar{Q}$ output from clear (SN54S175, SN74S175 only)	$C_L = 15 \text{ pF},$ $R_L = 280 \Omega,$ See Note 3		10	15	ns
$t_{PHL}$ Propagation delay time, high-to-low-level Q output from clear			13	22	ns
$t_{PLH}$ Propagation delay time, low-to-high-level output from clock			8	12	ns
$t_{PHL}$ Propagation time, high-to-low-level output from clock			11.5	17	ns

NOTE 3: Load circuits and voltage waveforms are shown in Section 1.





www.ti.com

PACKAG

**PACKAGING INFORMATION**

Orderable Device	Status <sup>(1)</sup>	Package Type	Package Drawing	Pins	Package Qty	Eco Plan <sup>(2)</sup>	Lead/Ball Finish	MSL Pe
JM38510/01702BEA	OBSOLETE	CDIP	J	16		TBD	Call TI	Call TI
JM38510/01702BFA	OBSOLETE	CFP	W	16		TBD	Call TI	Call TI
JM38510/07105BEA	ACTIVE	CDIP	J	16	1	TBD	A42	N / A for Pkg
JM38510/07105BFA	ACTIVE	CFP	W	16	1	TBD	A42	N / A for Pkg
JM38510/07106BEA	ACTIVE	CDIP	J	16	1	TBD	A42	N / A for Pkg
JM38510/30106B2A	ACTIVE	LCCC	FK	20	1	TBD	POST-PLATE	N / A for Pkg
JM38510/30106BEA	ACTIVE	CDIP	J	16	1	TBD	A42	N / A for Pkg
JM38510/30106BFA	ACTIVE	CFP	W	16	1	TBD	A42	N / A for Pkg
JM38510/30107B2A	ACTIVE	LCCC	FK	20	1	TBD	POST-PLATE	N / A for Pkg
JM38510/30107BEA	ACTIVE	CDIP	J	16	1	TBD	A42	N / A for Pkg
JM38510/30107BFA	ACTIVE	CFP	W	16	1	TBD	A42	N / A for Pkg
JM38510/30107SEA	ACTIVE	CDIP	J	16	1	TBD	A42	N / A for Pkg
JM38510/30107SFA	ACTIVE	CFP	W	16	1	TBD	A42	N / A for Pkg
SN54175J	OBSOLETE	CDIP	J	16		TBD	Call TI	Call TI
SN54LS174J	ACTIVE	CDIP	J	16	1	TBD	A42	N / A for Pkg
SN54LS175J	ACTIVE	CDIP	J	16	1	TBD	A42	N / A for Pkg
SN54S174J	ACTIVE	CDIP	J	16	1	TBD	A42	N / A for Pkg
SN54S175J	ACTIVE	CDIP	J	16	1	TBD	A42	N / A for Pkg
SN74174N	OBSOLETE	PDIP	N	16		TBD	Call TI	Call TI
SN74175N	OBSOLETE	PDIP	N	16		TBD	Call TI	Call TI
SN74175N3	OBSOLETE	PDIP	N	16		TBD	Call TI	Call TI
SN74LS174D	ACTIVE	SOIC	D	16	40	Green (RoHS & no Sb/Br)	CU NIPDAU	Level-1-2600
SN74LS174DE4	ACTIVE	SOIC	D	16	40	Green (RoHS & no Sb/Br)	CU NIPDAU	Level-1-2600
SN74LS174DG4	ACTIVE	SOIC	D	16	40	Green (RoHS & no Sb/Br)	CU NIPDAU	Level-1-2600
SN74LS174DR	ACTIVE	SOIC	D	16	2500	Green (RoHS & no Sb/Br)	CU NIPDAU	Level-1-2600



www.ti.com

PACKAG

Orderable Device	Status <sup>(1)</sup>	Package Type	Package Drawing	Pins	Package Qty	Eco Plan <sup>(2)</sup>	Lead/ Ball Finish	MSL Pea
SN74LS174DRE4	ACTIVE	SOIC	D	16	2500	Green (RoHS & no Sb/Br)	CU NIPDAU	Level-1-2600
SN74LS174DRG4	ACTIVE	SOIC	D	16	2500	Green (RoHS & no Sb/Br)	CU NIPDAU	Level-1-2600
SN74LS174J	OBSOLETE	CDIP	J	16		TBD	Call TI	Call TI
SN74LS174N	ACTIVE	PDIP	N	16	25	Pb-Free (RoHS)	CU NIPDAU	N / A for Pkg
SN74LS174N3	OBSOLETE	PDIP	N	16		TBD	Call TI	Call TI
SN74LS174NE4	ACTIVE	PDIP	N	16	25	Pb-Free (RoHS)	CU NIPDAU	N / A for Pkg
SN74LS174NSR	ACTIVE	SO	NS	16	2000	Green (RoHS & no Sb/Br)	CU NIPDAU	Level-1-2600
SN74LS174NSRE4	ACTIVE	SO	NS	16	2000	Green (RoHS & no Sb/Br)	CU NIPDAU	Level-1-2600
SN74LS174NSRG4	ACTIVE	SO	NS	16	2000	Green (RoHS & no Sb/Br)	CU NIPDAU	Level-1-2600
SN74LS175D	ACTIVE	SOIC	D	16	40	Green (RoHS & no Sb/Br)	CU NIPDAU	Level-1-2600
SN74LS175DE4	ACTIVE	SOIC	D	16	40	Green (RoHS & no Sb/Br)	CU NIPDAU	Level-1-2600
SN74LS175DG4	ACTIVE	SOIC	D	16	40	Green (RoHS & no Sb/Br)	CU NIPDAU	Level-1-2600
SN74LS175DR	ACTIVE	SOIC	D	16	2500	Green (RoHS & no Sb/Br)	CU NIPDAU	Level-1-2600
SN74LS175DRE4	ACTIVE	SOIC	D	16	2500	Green (RoHS & no Sb/Br)	CU NIPDAU	Level-1-2600
SN74LS175DRG4	ACTIVE	SOIC	D	16	2500	Green (RoHS & no Sb/Br)	CU NIPDAU	Level-1-2600
SN74LS175J	OBSOLETE	CDIP	J	16		TBD	Call TI	Call TI
SN74LS175N	ACTIVE	PDIP	N	16	25	Pb-Free (RoHS)	CU NIPDAU	N / A for Pkg
SN74LS175N3	OBSOLETE	PDIP	N	16		TBD	Call TI	Call TI
SN74LS175NE4	ACTIVE	PDIP	N	16	25	Pb-Free (RoHS)	CU NIPDAU	N / A for Pkg
SN74LS175NSR	ACTIVE	SO	NS	16	2000	Green (RoHS & no Sb/Br)	CU NIPDAU	Level-1-2600
SN74LS175NSRE4	ACTIVE	SO	NS	16	2000	Green (RoHS & no Sb/Br)	CU NIPDAU	Level-1-2600





www.ti.com

PACKAG

Orderable Device	Status <sup>(1)</sup>	Package Type	Package Drawing	Pins	Package Qty	Eco Plan <sup>(2)</sup>	Lead/ Ball Finish	MSL Pea
SN74LS175NSRG4	ACTIVE	SO	NS	16	2000	Green (RoHS & no Sb/Br)	CU NIPDAU	Level-1-2600
SN74S174J	OBSOLETE	CDIP	J	16		TBD	Call TI	Call TI
SN74S174N	NRND	PDIP	N	16	25	Pb-Free (RoHS)	CU NIPDAU	N / A for Pkg
SN74S174N3	OBSOLETE	PDIP	N	16		TBD	Call TI	Call TI
SN74S174NE4	NRND	PDIP	N	16	25	Pb-Free (RoHS)	CU NIPDAU	N / A for Pkg
SN74S175D	ACTIVE	SOIC	D	16	40	Green (RoHS & no Sb/Br)	CU NIPDAU	Level-1-2600
SN74S175DE4	ACTIVE	SOIC	D	16	40	Green (RoHS & no Sb/Br)	CU NIPDAU	Level-1-2600
SN74S175DG4	ACTIVE	SOIC	D	16	40	Green (RoHS & no Sb/Br)	CU NIPDAU	Level-1-2600
SN74S175DR	OBSOLETE	SOIC	D	16		TBD	Call TI	Call TI
SN74S175N	ACTIVE	PDIP	N	16	25	Pb-Free (RoHS)	CU NIPDAU	N / A for Pkg
SN74S175N3	OBSOLETE	PDIP	N	16		TBD	Call TI	Call TI
SN74S175NE4	ACTIVE	PDIP	N	16	25	Pb-Free (RoHS)	CU NIPDAU	N / A for Pkg
SNJ54175J	OBSOLETE	CDIP	J	16		TBD	Call TI	Call TI
SNJ54175W	OBSOLETE	CFP	W	16		TBD	Call TI	Call TI
SNJ54LS174FK	ACTIVE	LCCC	FK	20	1	TBD	POST-PLATE	N / A for Pkg
SNJ54LS174J	ACTIVE	CDIP	J	16	1	TBD	A42	N / A for Pkg
SNJ54LS174W	ACTIVE	CFP	W	16	1	TBD	A42	N / A for Pkg
SNJ54LS175FK	ACTIVE	LCCC	FK	20	1	TBD	POST-PLATE	N / A for Pkg
SNJ54LS175J	ACTIVE	CDIP	J	16	1	TBD	A42	N / A for Pkg
SNJ54LS175W	ACTIVE	CFP	W	16	1	TBD	A42	N / A for Pkg
SNJ54S174FK	ACTIVE	LCCC	FK	20	1	TBD	POST-PLATE	N / A for Pkg
SNJ54S174J	ACTIVE	CDIP	J	16	1	TBD	A42	N / A for Pkg
SNJ54S174W	ACTIVE	CFP	W	16	1	TBD	A42	N / A for Pkg
SNJ54S175FK	ACTIVE	LCCC	FK	20	1	TBD	POST-PLATE	N / A for Pkg
SNJ54S175J	ACTIVE	CDIP	J	16	1	TBD	A42	N / A for Pkg
SNJ54S175W	ACTIVE	CFP	W	16	1	TBD	A42	N / A for Pkg

<sup>(1)</sup> The marketing status values are defined as follows:  
**ACTIVE:** Product device recommended for new designs.



www.ti.com

PACKAG

**LIFEBUY:** TI has announced that the device will be discontinued, and a lifetime-buy period is in effect.

**NRND:** Not recommended for new designs. Device is in production to support existing customers, but TI does not recommend using this part in a new design.

**PREVIEW:** Device has been announced but is not in production. Samples may or may not be available.

**OBSOLETE:** TI has discontinued the production of the device.

<sup>(2)</sup> Eco Plan - The planned eco-friendly classification: Pb-Free (RoHS), Pb-Free (RoHS Exempt), or Green (RoHS & no Sb/Br) - please check <http://www.ti.com> for more information and additional product content details.

**TBD:** The Pb-Free/Green conversion plan has not been defined.

**Pb-Free (RoHS):** TI's terms "Lead-Free" or "Pb-Free" mean semiconductor products that are compatible with the current RoHS requirements for all lead-based materials. Lead content must not exceed 0.1% by weight in homogeneous materials. Where designed to be soldered at high temperatures, TI Pb-Free products are suitable for use in high temperature applications.

**Pb-Free (RoHS Exempt):** This component has a RoHS exemption for either 1) lead-based flip-chip solder bumps used between the die and package, or 2) lead-based leadframe materials used in the die and leadframe. The component is otherwise considered Pb-Free (RoHS compatible) as defined above.

**Green (RoHS & no Sb/Br):** TI defines "Green" to mean Pb-Free (RoHS compatible), and free of Bromine (Br) and Antimony (Sb) based flame retardants (both in homogeneous material and in the package).

<sup>(3)</sup> MSL, Peak Temp. -- The Moisture Sensitivity Level rating according to the JEDEC industry standard classifications, and peak solder temperature.

**Important Information and Disclaimer:** The information provided on this page represents TI's knowledge and belief as of the date that it is provided. TI disclaims any warranty, express or implied, for the information provided by third parties, and makes no representation or warranty as to the accuracy of such information. Efforts are underway to better integrate information from third parties into TI's data sheets and/or to provide more representative and accurate information but may not have conducted destructive testing or chemical analysis for all products and all applications. TI and TI suppliers consider certain information to be proprietary, and thus CAS numbers and other limited information may not be available for release. For more information, contact your TI representative.

In no event shall TI's liability arising out of such information exceed the total purchase price of the TI part(s) at issue in this document sold by TI to Customer.

**OTHER QUALIFIED VERSIONS OF SN54175, SN54LS174, SN54LS175, SN54LS175-SP, SN54S174, SN54S175, SN74175, SN74LS174, SN74LS175, SN74S175 :**

● Catalog: [SN74175](#), [SN74LS174](#), [SN74LS175](#), [SN54LS175](#), [SN74S174](#), [SN74S175](#)

● Military: [SN54175](#), [SN54LS174](#), [SN54LS175](#), [SN54S174](#), [SN54S175](#)

● Space: [SN54LS175-SP](#)

NOTE: Qualified Version Definitions:

- Catalog - TI's standard catalog product
- Military - QML certified for Military and Defense Applications
- Space - Radiation tolerant, ceramic packaging and qualified for use in Space-based application

**TAPE AND REEL INFORMATION**

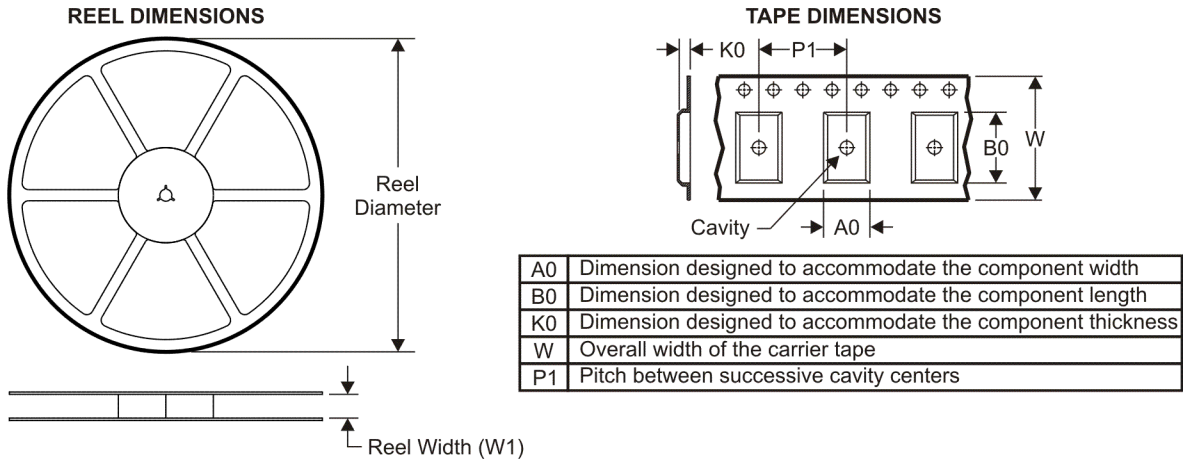

**QUADRANT ASSIGNMENTS FOR PIN 1 ORIENTATION IN TAPE**

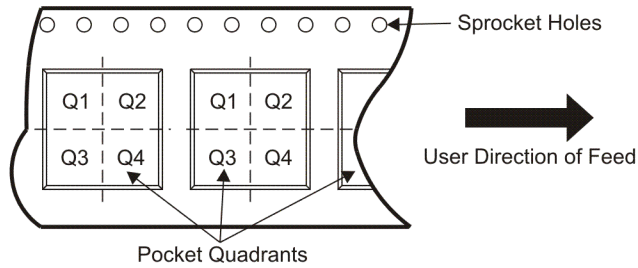

\*All dimensions are nominal

Device	Package Type	Package Drawing	Pins	SPQ	Reel Diameter (mm)	Reel Width W1 (mm)	A0 (mm)	B0 (mm)	K0 (mm)	P1 (mm)	W (mm)	Pin1 Quadrant
SN74LS174DR	SOIC	D	16	2500	330.0	16.4	6.5	10.3	2.1	8.0	16.0	Q1
SN74LS174NSR	SO	NS	16	2000	330.0	16.4	8.2	10.5	2.5	12.0	16.0	Q1
SN74LS175DR	SOIC	D	16	2500	330.0	16.4	6.5	10.3	2.1	8.0	16.0	Q1
SN74LS175NSR	SO	NS	16	2000	330.0	16.4	8.2	10.5	2.5	12.0	16.0	Q1

**TAPE AND REEL BOX DIMENSIONS**



\*All dimensions are nominal

Device	Package Type	Package Drawing	Pins	SPQ	Length (mm)	Width (mm)	Height (mm)
SN74LS174DR	SOIC	D	16	2500	333.2	345.9	28.6
SN74LS174NSR	SO	NS	16	2000	346.0	346.0	33.0
SN74LS175DR	SOIC	D	16	2500	333.2	345.9	28.6
SN74LS175NSR	SO	NS	16	2000	346.0	346.0	33.0

## IMPORTANT NOTICE

Texas Instruments Incorporated and its subsidiaries (TI) reserve the right to make corrections, modifications, enhancements, improvements, and other changes to its products and services at any time and to discontinue any product or service without notice. Customers should obtain the latest relevant information before placing orders and should verify that such information is current and complete. All products are sold subject to TI's terms and conditions of sale supplied at the time of order acknowledgment.

TI warrants performance of its hardware products to the specifications applicable at the time of sale in accordance with TI's standard warranty. Testing and other quality control techniques are used to the extent TI deems necessary to support this warranty. Except where mandated by government requirements, testing of all parameters of each product is not necessarily performed.

TI assumes no liability for applications assistance or customer product design. Customers are responsible for their products and applications using TI components. To minimize the risks associated with customer products and applications, customers should provide adequate design and operating safeguards.

TI does not warrant or represent that any license, either express or implied, is granted under any TI patent right, copyright, mask work right, or other TI intellectual property right relating to any combination, machine, or process in which TI products or services are used. Information published by TI regarding third-party products or services does not constitute a license from TI to use such products or services or a warranty or endorsement thereof. Use of such information may require a license from a third party under the patents or other intellectual property of the third party, or a license from TI under the patents or other intellectual property of TI.

Reproduction of TI information in TI data books or data sheets is permissible only if reproduction is without alteration and is accompanied by all associated warranties, conditions, limitations, and notices. Reproduction of this information with alteration is an unfair and deceptive business practice. TI is not responsible or liable for such altered documentation. Information of third parties may be subject to additional restrictions.

Resale of TI products or services with statements different from or beyond the parameters stated by TI for that product or service voids all express and any implied warranties for the associated TI product or service and is an unfair and deceptive business practice. TI is not responsible or liable for any such statements.

TI products are not authorized for use in safety-critical applications (such as life support) where a failure of the TI product would reasonably be expected to cause severe personal injury or death, unless officers of the parties have executed an agreement specifically governing such use. Buyers represent that they have all necessary expertise in the safety and regulatory ramifications of their applications, and acknowledge and agree that they are solely responsible for all legal, regulatory and safety-related requirements concerning their products and any use of TI products in such safety-critical applications, notwithstanding any applications-related information or support that may be provided by TI. Further, Buyers must fully indemnify TI and its representatives against any damages arising out of the use of TI products in such safety-critical applications.

TI products are neither designed nor intended for use in military/aerospace applications or environments unless the TI products are specifically designated by TI as military-grade or "enhanced plastic." Only products designated by TI as military-grade meet military specifications. Buyers acknowledge and agree that any such use of TI products which TI has not designated as military-grade is solely at the Buyer's risk, and that they are solely responsible for compliance with all legal and regulatory requirements in connection with such use.

TI products are neither designed nor intended for use in automotive applications or environments unless the specific TI products are designated by TI as compliant with ISO/TS 16949 requirements. Buyers acknowledge and agree that, if they use any non-designated products in automotive applications, TI will not be responsible for any failure to meet such requirements.

Following are URLs where you can obtain information on other Texas Instruments products and application solutions:

<b>Products</b>		<b>Applications</b>	
Amplifiers	<a href="http://amplifier.ti.com">amplifier.ti.com</a>	Audio	<a href="http://www.ti.com/audio">www.ti.com/audio</a>
Data Converters	<a href="http://dataconverter.ti.com">dataconverter.ti.com</a>	Automotive	<a href="http://www.ti.com/automotive">www.ti.com/automotive</a>
DLP® Products	<a href="http://www.dlp.com">www.dlp.com</a>	Communications and Telecom	<a href="http://www.ti.com/communications">www.ti.com/communications</a>
DSP	<a href="http://dsp.ti.com">dsp.ti.com</a>	Computers and Peripherals	<a href="http://www.ti.com/computers">www.ti.com/computers</a>
Clocks and Timers	<a href="http://www.ti.com/clocks">www.ti.com/clocks</a>	Consumer Electronics	<a href="http://www.ti.com/consumer-apps">www.ti.com/consumer-apps</a>
Interface	<a href="http://interface.ti.com">interface.ti.com</a>	Energy	<a href="http://www.ti.com/energy">www.ti.com/energy</a>
Logic	<a href="http://logic.ti.com">logic.ti.com</a>	Industrial	<a href="http://www.ti.com/industrial">www.ti.com/industrial</a>
Power Mgmt	<a href="http://power.ti.com">power.ti.com</a>	Medical	<a href="http://www.ti.com/medical">www.ti.com/medical</a>
Microcontrollers	<a href="http://microcontroller.ti.com">microcontroller.ti.com</a>	Security	<a href="http://www.ti.com/security">www.ti.com/security</a>
RFID	<a href="http://www.ti-rfid.com">www.ti-rfid.com</a>	Space, Avionics & Defense	<a href="http://www.ti.com/space-avionics-defense">www.ti.com/space-avionics-defense</a>
RF/IF and ZigBee® Solutions	<a href="http://www.ti.com/lprf">www.ti.com/lprf</a>	Video and Imaging	<a href="http://www.ti.com/video">www.ti.com/video</a>
		Wireless	<a href="http://www.ti.com/wireless-apps">www.ti.com/wireless-apps</a>