

High-Accuracy, Low-Power, Digital Temperature Sensor With SMBus™/Two-Wire Serial Interface in SOT563

FEATURES

- **TINY SOT563 PACKAGE**
- **ACCURACY:**
0.5°C (max) from 0°C to +65°C
1.0°C (max) from -40°C to +125°C
- **LOW QUIESCENT CURRENT:**
10µA Active (max), 1µA Shutdown (max)
- **SUPPLY RANGE: 1.4V to 3.6V**
- **RESOLUTION: 12 Bits**
- **DIGITAL OUTPUT: Two-Wire Serial Interface**

APPLICATIONS

- **PORTABLE AND BATTERY-POWERED APPLICATIONS**
- **POWER-SUPPLY TEMPERATURE MONITORING**
- **COMPUTER PERIPHERAL THERMAL PROTECTION**
- **NOTEBOOK COMPUTERS**
- **BATTERY MANAGEMENT**
- **OFFICE MACHINES**
- **THERMOSTAT CONTROLS**
- **ELECTROMECHANICAL DEVICE TEMPERATURES**
- **GENERAL TEMPERATURE MEASUREMENTS:**
Industrial Controls
Test Equipment
Medical Instrumentation

DESCRIPTION

The TMP112 is a two-wire, serial output temperature sensor available in a tiny SOT563 package. Requiring no external components, the TMP112 is capable of reading temperatures to a resolution of 0.0625°C. The [TMP112 slope-specification](#) allows users to calibrate for higher accuracy.

The TMP112 features both SMBus and two-wire interface compatibility, and allows up to four devices on one bus. It also features an SMBus alert function.

The TMP112 is ideal for extended temperature measurement in communication, computer, consumer, environmental, industrial, and instrumentation applications. It is specified for operation over a temperature range of -40°C to +125°C.

TEMPERATURE ERROR AT +25°C

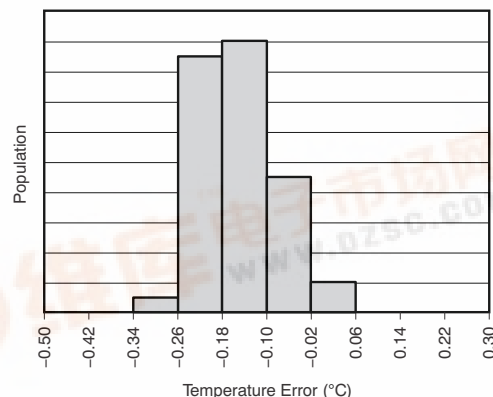

Please be aware that an important notice concerning availability, standard warranty, and use in critical applications of Texas Instruments semiconductor products and disclaimers thereto appears at the end of this data sheet.

SMBus is a trademark of Intel, Inc.

All other trademarks are the property of their respective owners.

PRODUCTION DATA information is current as of publication date. Products conform to specifications per the terms of the Texas Instruments standard warranty. Production processing does not necessarily include testing of all parameters.

Copyright © 2009, Texas Instruments Incorporated



[查询TMP112供应商](#)



This integrated circuit can be damaged by ESD. Texas Instruments recommends that all integrated circuits be handled with appropriate precautions. Failure to observe proper handling and installation procedures can cause damage.

ESD damage can range from subtle performance degradation to complete device failure. Precision integrated circuits may be more susceptible to damage because very small parametric changes could cause the device not to meet its published specifications.

PACKAGE INFORMATION⁽¹⁾

PRODUCT	PACKAGE-LEAD	PACKAGE DESIGNATOR	PACKAGE MARKING
TMP112	SOT563	DRL	OBS

(1) For the most current package and ordering information, see the Package Option Addendum at the end of this document, or see the TI web site at www.ti.com.

ABSOLUTE MAXIMUM RATINGS⁽¹⁾

PARAMETER	TMP112	UNIT
Supply Voltage	5	V
Input Voltage, Pins 1, 4, and 6	-0.5 to +5	V
Input Voltage, Pin 3	-0.5 to (V _S) + 0.5	V
Operating Temperature	-55 to +150	°C
Storage Temperature	-60 to +150	°C
Junction Temperature	+150	°C
ESD Rating	Human Body Model (HBM)	2000
	Charged Device Model (CDM)	1000
	Machine Model (MM)	200

(1) Stresses above these ratings may cause permanent damage. Exposure to absolute maximum conditions for extended periods may degrade device reliability. These are stress ratings only, and functional operation of the device at these or any other conditions beyond those specified is not supported.

PIN CONFIGURATION

**DRL PACKAGE
SOT563
(TOP VIEW)**

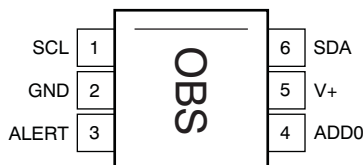

ELECTRICAL CHARACTERISTICS

 At $T_A = +25^\circ\text{C}$ and $V_S = +1.4\text{V}$ to $+3.6\text{V}$, unless otherwise noted.

PARAMETER	CONDITIONS	TMP112			UNIT
		MIN	TYP	MAX	
TEMPERATURE INPUT					
Range		–40		+125	$^\circ\text{C}$
Accuracy (Temperature Error)	+25 $^\circ\text{C}$, $V_S = 3.3\text{V}$	–0.5	–0.1	+0.3	$^\circ\text{C}$
	0 $^\circ\text{C}$ to +65 $^\circ\text{C}$, $V_S = 3.3\text{V}$	–0.5		+0.5	$^\circ\text{C}$
	–40 $^\circ\text{C}$ to +125 $^\circ\text{C}$	–1.0		1.0	$^\circ\text{C}$
	vs Supply		+0.0625	± 0.25	$^\circ\text{C}/\text{V}$
Long-Term Stability	3000 Hours		< 1		LSB
Resolution (LSB)			0.0625		$^\circ\text{C}$
DIGITAL INPUT/OUTPUT					
Input Logic Levels:					
V_{IH}		0.7 (V+)		3.6	V
V_{IL}		–0.5		0.3 (V+)	V
Input Current	I_{IN} 0 < V_{IN} < 3.6V			1	μA
Output Logic Levels:					
V_{OL} SDA	$V_+ > 2\text{V}$, $I_{OL} = 3\text{mA}$	0		0.4	V
	$V_+ < 2\text{V}$, $I_{OL} = 3\text{mA}$	0		0.2 (V+)	V
V_{OL} ALERT	$V_+ > 2\text{V}$, $I_{OL} = 3\text{mA}$	0		0.4	V
	$V_+ < 2\text{V}$, $I_{OL} = 3\text{mA}$	0		0.2 (V+)	V
Resolution			12		Bits
Conversion Time			26	35	ms
Conversion Modes	CR1 = 0, CR0 = 0		0.25		Conv/s
	CR1 = 0, CR0 = 1		1		Conv/s
	CR1 = 1, CR0 = 0 (default)		4		Conv/s
	CR1 = 1, CR0 = 1		8		Conv/s
Timeout Time			30	40	ms
POWER SUPPLY					
Operating Supply Range		+1.4		+3.6	V
Quiescent Current	I_Q Serial Bus Inactive, CR1 = 1, CR0 = 0 (default)		7	10	μA
			15		μA
			85		μA
Shutdown Current	I_{SD} Serial Bus Inactive		0.5	1	μA
			10		μA
			80		μA
	Serial Bus Active, SCL Frequency = 400kHz				μA
	Serial Bus Active, SCL Frequency = 3.4MHz				μA
TEMPERATURE RANGE					
Specified Range		–40		+125	$^\circ\text{C}$
Operating Range		–55		+150	$^\circ\text{C}$
Thermal Resistance	θ_{JA} JEDEC Low-K Board		260		$^\circ\text{C}/\text{W}$
	SOT563				

TYPICAL CHARACTERISTICS

At $T_A = +25^\circ\text{C}$ and $V+ = 3.3\text{V}$, unless otherwise noted.

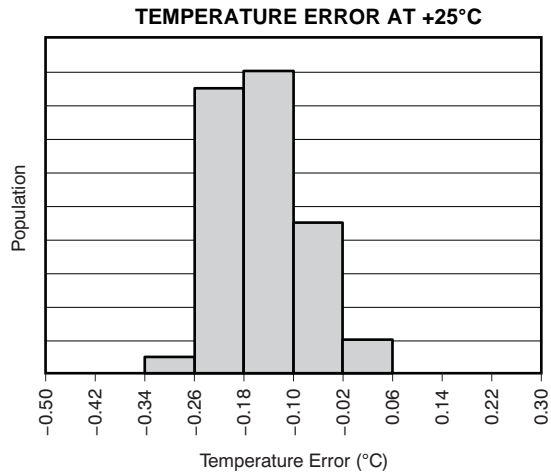

Figure 1.

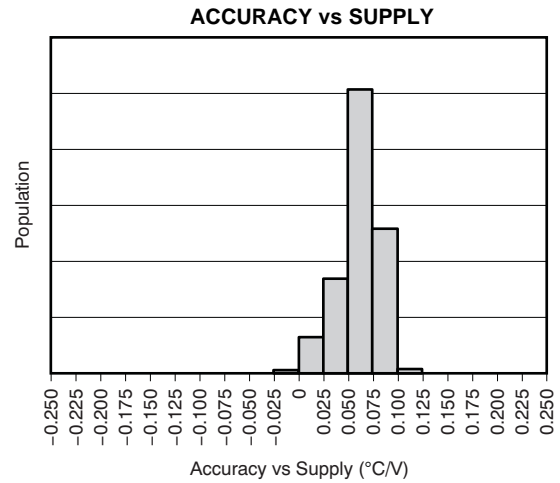

Figure 2.

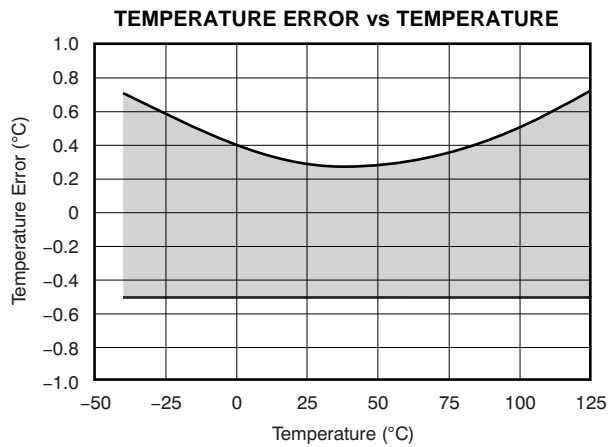

Figure 3.

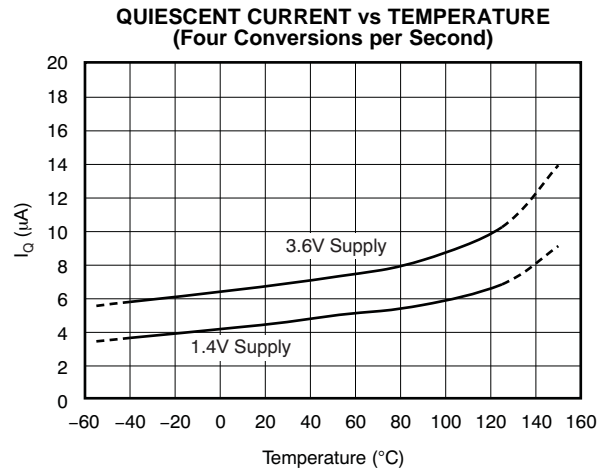

Figure 4.

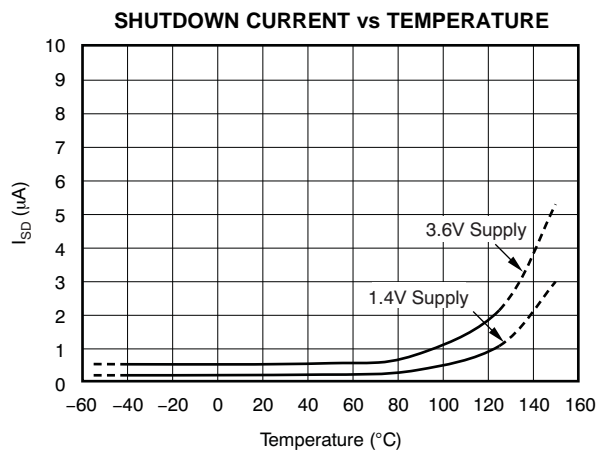

Figure 5.

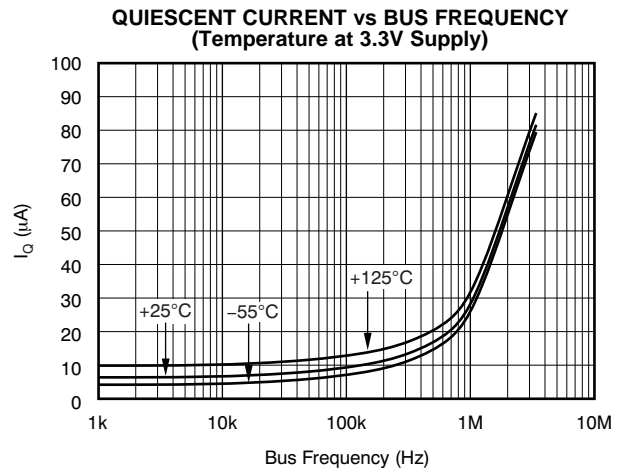

Figure 6.

TYPICAL CHARACTERISTICS (continued)

At $T_A = +25^\circ\text{C}$ and $V_+ = 3.3\text{V}$, unless otherwise noted.

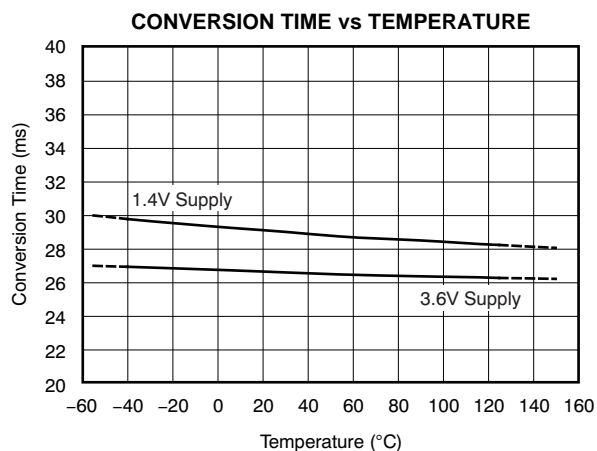

Figure 7.

[查询TMP112供应商](#)

APPLICATION INFORMATION

The TMP112 is a digital temperature sensor that is optimal for thermal-management and thermal-protection applications. A block diagram of the TMP112 is shown in Figure 8. The TMP112 is two-wire- and SMBus interface-compatible, and is specified over an operating temperature range of -40°C to $+125^{\circ}\text{C}$. Figure 9 illustrates the ESD protection circuitry contained in the TMP112.

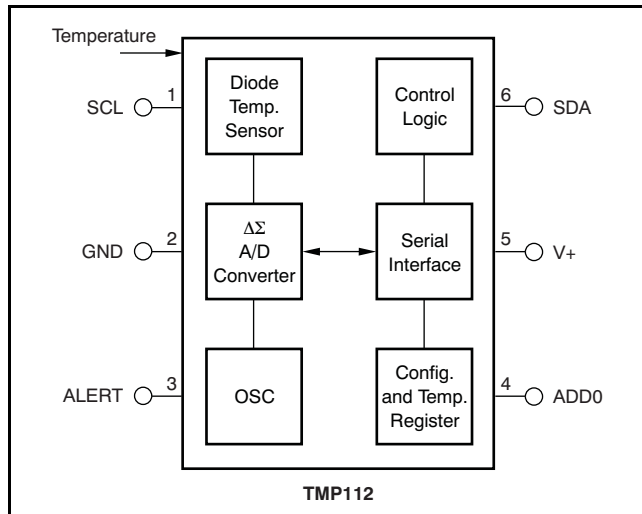

Figure 8. Internal Block Diagram

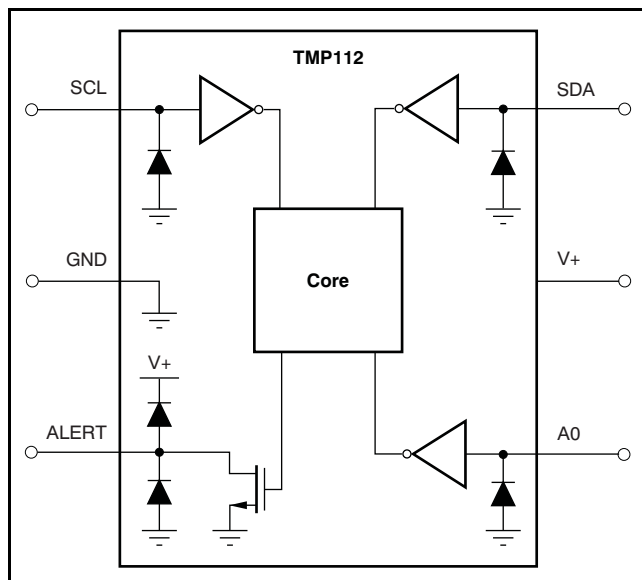

Figure 9. Equivalent Internal ESD Circuitry

Pull-up resistors are required on SCL, SDA, and ALERT. A $0.01\mu\text{F}$ bypass capacitor is recommended, as shown in Figure 10.

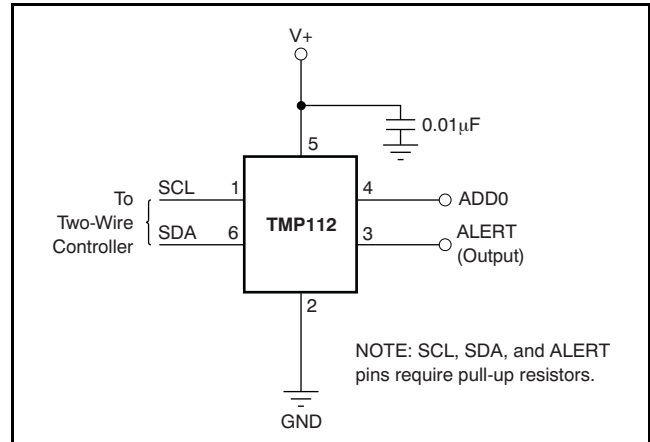

Figure 10. Typical Connections

The temperature sensor in the TMP112 is the chip itself. Thermal paths run through the package leads as well as the plastic package. The lower thermal resistance of metal causes the leads to provide the primary thermal path.

To maintain accuracy in applications that require air or surface temperature measurement, care should be taken to isolate the package and leads from ambient air temperature. A thermally-conductive adhesive is helpful in achieving accurate surface temperature measurement.

POINTER REGISTER

Figure 11 shows the internal register structure of the TMP112. The 8-bit Pointer Register of the device is used to address a given data register. The Pointer Register uses the two LSBs (see Table 1) to identify which of the data registers should respond to a read or write command. Table 1 identifies the bits of the Pointer Register byte. During a write command, P2 through P7 must always be '0'. Table 2 describes the pointer address of the registers available in the TMP112. The power-up reset value of P1/P0 is '00'. By default, the TMP112 reads the temperature on power-up.

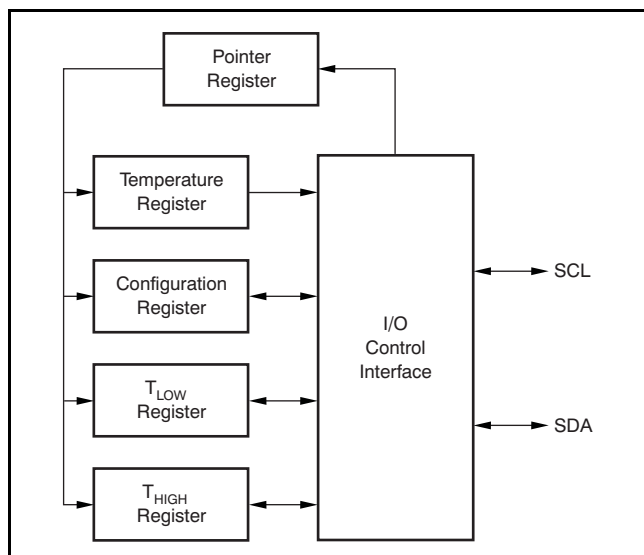

Figure 11. Internal Register Structure

Table 1. Pointer Register Byte

P7	P6	P5	P4	P3	P2	P1	P0
0	0	0	0	0	0	Register Bits	

Table 2. Pointer Addresses

P1	P0	REGISTER
0	0	Temperature Register (Read Only)
0	1	Configuration Register (Read/Write)
1	0	T _{LOW} Register (Read/Write)
1	1	T _{HIGH} Register (Read/Write)

TEMPERATURE REGISTER

The Temperature Register of the TMP112 is configured as a 12-bit, read-only register (Configuration Register EM bit = '0'; see the *Extended Mode* section), or as a 13-bit, read-only register (Configuration Register EM bit = '1') that stores the output of the most recent conversion. Two bytes must be read to obtain data, and are described in Table 3 and Table 4. Note that byte 1 is the most significant byte (MSB), followed by byte 2, the least significant byte (LSB). The first 12 bits (13 bits in Extended mode) are used to indicate temperature. The least significant byte does not have to be read if that information is not needed. The data format for temperature is summarized in Table 5 and Table 6. One LSB equals 0.0625°C. Negative numbers are represented in binary twos complement format. Following power-up or reset, the Temperature Register reads 0°C until the first conversion is complete. Bit D0 of byte 2 indicates Normal mode (EM bit = '0') or Extended mode (EM bit = '1'), and can be used to distinguish between the two temperature register data formats. The unused bits in the Temperature Register always read '0'.

Table 3. Byte 1 of Temperature Register⁽¹⁾

D7	D6	D5	D4	D3	D2	D1	D0
T11	T10	T9	T8	T7	T6	T5	T4
(T12)	(T11)	(T10)	(T9)	(T8)	(T7)	(T6)	(T5)

(1) Extended mode 13-bit configuration shown in parentheses.

Table 4. Byte 2 of Temperature Register⁽¹⁾

D7	D6	D5	D4	D3	D2	D1	D0
T3	T2	T1	T0	0	0	0	0
(T4)	(T3)	(T2)	(T1)	(T0)	(0)	(0)	(1)

(1) Extended mode 13-bit configuration shown in parentheses.

[查询TMP112供应商](#)

Table 5. 12-Bit Temperature Data Format⁽¹⁾

TEMPERATURE (°C)	DIGITAL OUTPUT (BINARY)	HEX
128	0111 1111 1111	7FF
127.9375	0111 1111 1111	7FF
100	0110 0100 0000	640
80	0101 0000 0000	500
75	0100 1011 0000	4B0
50	0011 0010 0000	320
25	0001 1001 0000	190
0.25	0000 0000 0100	004
0	0000 0000 0000	000
-0.25	1111 1111 1100	FFC
-25	1110 0111 0000	E70
-55	1100 1001 0000	C90

(1) The resolution for the Temp ADC in Internal Temperature mode is 0.0625°C/count.

For positive temperatures (for example, +50°C):

Twos complement is not performed on positive numbers. Therefore, simply convert the number to binary code with the 12-bit, left-justified format, and MSB = 0 to denote a positive sign.

Example: $(+50^{\circ}\text{C}) / (0.0625^{\circ}\text{C}/\text{count}) = 800 = 320\text{h} = 0011\ 0010\ 0000$

For negative temperatures (for example, -25°C):

Generate the twos complement of a negative number by complementing the absolute value binary number and adding 1. Denote a negative number with MSB = 1.

Example: $(|-25^{\circ}\text{C}|) / (0.0625^{\circ}\text{C}/\text{count}) = 400 = 190\text{h} = 0001\ 1001\ 0000$

Twos complement format: $1110\ 0110\ 1111 + 1 = 1110\ 0111\ 0000$

Table 6. 13-Bit Temperature Data Format

TEMPERATURE (°C)	DIGITAL OUTPUT (BINARY)	HEX
150	0 1001 0110 0000	0960
128	0 1000 0000 0000	0800
127.9375	0 0111 1111 1111	07FF
100	0 0110 0100 0000	0640
80	0 0101 0000 0000	0500
75	0 0100 1011 0000	04B0
50	0 0011 0010 0000	0320
25	0 0001 1001 0000	0190
0.25	0 0000 0000 0100	0004
0	0 0000 0000 0000	0000
-0.25	1 1111 1111 1100	1FFC
-25	1 1110 0111 0000	1E70
-55	1 1100 1001 0000	1C90

CONFIGURATION REGISTER

The Configuration Register is a 16-bit read/write register used to store bits that control the operational modes of the temperature sensor. Read/write operations are performed MSB first. The format and power-up/reset values of the Configuration Register are shown in [Table 7](#). For compatibility, the first byte corresponds to the Configuration Register in the [TMP75](#) and [TMP275](#). All registers are updated byte by byte.

Table 7. Configuration and Power-Up/Reset Formats

BYTE	D7	D6	D5	D4	D3	D2	D1	D0
1	OS	R1	R0	F1	F0	POL	TM	SD
	0	1	1	0	0	0	0	0
2	CR1	CR0	AL	EM	0	0	0	0
	1	0	1	0	0	0	0	0

EXTENDED MODE (EM)

The Extended mode bit configures the device for Normal mode operation (EM = 0) or Extended mode operation (EM = 1). In Normal mode, the Temperature Register and high- and low-limit registers use a 12-bit data format. Normal mode is used to make the TMP112 compatible with the [TMP75](#).

Extended mode (EM = 1) allows measurement of temperatures above +128°C by configuring the Temperature Register, and high- and low-limit registers, for 13-bit data format.

ALERT (AL Bit)

The AL bit is a read-only function. Reading the AL bit provides information about the comparator mode status. The state of the POL bit inverts the polarity of data returned from the AL bit. For POL = 0, the AL bit reads as '1' until the temperature equals or exceeds T_{HIGH} for the programmed number of consecutive faults, causing the AL bit to read as '0'. The AL bit continues to read as '0' until the temperature falls below T_{LOW} for the programmed number of consecutive faults, when it again reads as '1'. The status of the TM bit does not affect the status of the AL bit.

CONVERSION RATE

The conversion rate bits, CR1 and CR0, configure the TMP112 for conversion rates of 8Hz, 4Hz, 1Hz, or 0.25Hz. The default rate is 4Hz. The TMP112 has a typical conversion time of 26ms. To achieve different conversion rates, the TMP112 makes a conversion and then powers down and waits for the appropriate delay set by CR1 and CR0. [Table 8](#) shows the settings for CR1 and CR0.

Table 8. Conversion Rate Settings

CR1	CR0	CONVERSION RATE
0	0	0.25Hz
0	1	1Hz
1	0	4Hz (default)
1	1	8Hz

After a power-up or general-call reset, the TMP112 immediately starts a conversion, as shown in [Figure 12](#). The first result is available after 26ms (typical). The active quiescent current during conversion is 40μA (typical at +27°C). The quiescent current during delay is 2.2μA (typical at +27°C).

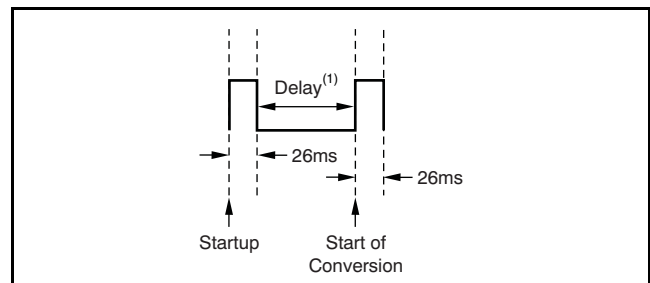

(1) Delay is set by CR1 and CR0.

Figure 12. Conversion Start

SHUTDOWN MODE (SD)

The Shutdown mode bit saves maximum power by shutting down all device circuitry other than the serial interface, reducing current consumption to typically less than 0.5μA. Shutdown mode is enabled when the SD bit = '1'; the device shuts down when current conversion is completed. When SD = '0', the device maintains a continuous conversion state.

THERMOSTAT MODE (TM)

The Thermostat mode bit indicates to the device whether to operate in Comparator mode (TM = 0) or Interrupt mode (TM = 1). For more information on Comparator and Interrupt modes, see the [High- and Low-Limit Registers](#) section.

POLARITY (POL)

The Polarity bit allows the user to adjust the polarity of the ALERT pin output. If POL = 0, the ALERT pin becomes active low, as shown in Figure 13. For POL = 1, the ALERT pin becomes active high, and the state of the ALERT pin is inverted.

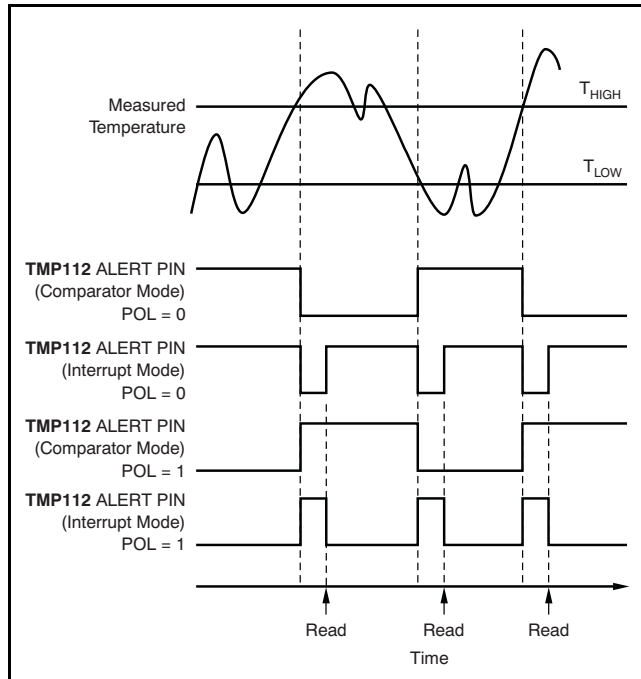

Figure 13. Output Transfer Function Diagrams

FAULT QUEUE (F1/F0)

A fault condition exists when the measured temperature exceeds the user-defined limits set in the T_{HIGH} and T_{LOW} registers. Additionally, the number of fault conditions required to generate an alert may be programmed using the fault queue. The fault queue is provided to prevent a false alert as a result of environmental noise. The fault queue requires consecutive fault measurements in order to trigger the alert function. Table 9 defines the number of measured faults that may be programmed to trigger an alert condition in the device. For T_{HIGH} and T_{LOW} register format and byte order, see the [High- and Low-Limit Registers](#) section.

Table 9. TMP112 Fault Settings

F1	F0	CONSECUTIVE FAULTS
0	0	1
0	1	2
1	0	4
1	1	6

CONVERTER RESOLUTION (R1/R0)

R1/R0 are read-only bits. The TMP112 converter resolution is set on start up to '11'. This sets the temperature register to a 12 bit-resolution.

ONE-SHOT/CONVERSION READY (OS)

The TMP112 features a One-Shot Temperature Measurement mode. When the device is in Shutdown mode, writing a '1' to the OS bit starts a single temperature conversion. During the conversion, the OS bit reads '0'. The device returns to the shutdown state at the completion of the single conversion. After the conversion, the OS bit reads '1'. This feature is useful for reducing power consumption in the TMP112 when continuous temperature monitoring is not required.

As a result of the short conversion time, the TMP112 can achieve a higher conversion rate. A single conversion typically takes 26ms and a read can take place in less than 20µs. When using One-Shot mode, 30 or more conversions per second are possible.

HIGH- AND LOW-LIMIT REGISTERS

In Comparator mode (TM = 0), the ALERT pin becomes active when the temperature equals or exceeds the value in T_{HIGH} and generates a consecutive number of faults according to fault bits F1 and F0. The ALERT pin remains active until the temperature falls below the indicated T_{LOW} value for the same number of faults.

In Interrupt mode (TM = 1), the ALERT pin becomes active when the temperature equals or exceeds the value in T_{HIGH} for a consecutive number of fault conditions (as shown in Table 9). The ALERT pin remains active until a read operation of any register occurs, or the device successfully responds to the SMBus Alert Response address. The ALERT pin is also cleared if the device is placed in Shutdown mode. Once the ALERT pin is cleared, it becomes active again only when temperature falls below T_{LOW} , and remains active until cleared by a read operation of any register or a successful response to the SMBus Alert Response address. Once the ALERT pin is cleared, the above cycle repeats, with the ALERT pin becoming active when the temperature equals or exceeds T_{HIGH} . The ALERT pin can also be cleared by resetting the device with the General Call Reset command. This action also clears the state of the internal registers in the device, returning the device to Comparator mode (TM = 0).

Both operating modes are represented in [Figure 13](#). [Table 10](#) and [Table 11](#) describe the format for the T_{HIGH} and T_{LOW} registers. Note that the most significant byte is sent first, followed by the least significant byte. Power-up reset values for T_{HIGH} and T_{LOW} are:

- $T_{HIGH} = +80^{\circ}\text{C}$
- $T_{LOW} = +75^{\circ}\text{C}$

The format of the data for T_{HIGH} and T_{LOW} is the same as for the Temperature Register.

Table 10. Bytes 1 and 2 of T_{HIGH} Register⁽¹⁾

BYTE	D7	D6	D5	D4	D3	D2	D1	D0
1	H11	H10	H9	H8	H7	H6	H5	H4
	(H12)	(H11)	(H10)	(H9)	(H8)	(H7)	(H6)	(H5)
BYTE	D7	D6	D5	D4	D3	D2	D1	D0
2	H3	H2	H1	H0	0	0	0	0
	(H4)	(H3)	(H2)	(H1)	(H0)	(0)	(0)	(0)

(1) Extended mode 13-bit configuration shown in parenthesis.

Table 11. Bytes 1 and 2 of T_{LOW} Register⁽¹⁾

BYTE	D7	D6	D5	D4	D3	D2	D1	D0
1	L11	L10	L9	L8	L7	L6	L5	L4
	(L12)	(L11)	(L10)	(L9)	(L8)	(L7)	(L6)	(L5)
BYTE	D7	D6	D5	D4	D3	D2	D1	D0
2	L3	L2	L1	L0	0	0	0	0
	(L4)	(L3)	(L2)	(L1)	(L0)	(0)	(0)	(0)

(1) Extended mode 13-bit configuration shown in parenthesis.

BUS OVERVIEW

The device that initiates the transfer is called a *master*, and the devices controlled by the master are *slaves*. The bus must be controlled by a master device that generates the serial clock (SCL), controls the bus access, and generates the START and STOP conditions.

To address a specific device, a START condition is initiated, indicated by pulling the data-line (SDA) from a high to low logic level while SCL is high. All slaves on the bus shift in the slave address byte on the rising edge of the clock, with the last bit indicating whether a read or write operation is intended. During the ninth clock pulse, the slave being addressed responds to the master by generating an Acknowledge and pulling SDA low.

Data transfer is then initiated and sent over eight clock pulses followed by an Acknowledge Bit. During data transfer SDA must remain stable while SCL is high, because any change in SDA while SCL is high is interpreted as a START or STOP signal.

Once all data have been transferred, the master generates a STOP condition indicated by pulling SDA from low to high, while SCL is high.

SERIAL INTERFACE

The TMP112 operates as a slave device only on the two-wire bus and SMBus. Connections to the bus are made via the open-drain I/O lines SDA and SCL. The SDA and SCL pins feature integrated spike suppression filters and Schmitt triggers to minimize the effects of input spikes and bus noise. The TMP112 supports the transmission protocol for both fast (1kHz to 400kHz) and high-speed (1kHz to 3.4MHz) modes. All data bytes are transmitted MSB first.

SERIAL BUS ADDRESS

To communicate with the TMP112, the master must first address slave devices via a slave address byte. The slave address byte consists of seven address bits, and a direction bit indicating the intent of executing a read or write operation.

The TMP112 features an address pin to allow up to four devices to be addressed on a single bus. [Table 12](#) describes the pin logic levels used to properly connect up to four devices.

Table 12. Address Pin and Slave Addresses

DEVICE TWO-WIRE ADDRESS	A0 PIN CONNECTION
1001000	Ground
1001001	V+
1001010	SDA
1001011	SCL

WRITING/READING OPERATION

Accessing a particular register on the TMP112 is accomplished by writing the appropriate value to the Pointer Register. The value for the Pointer Register is the first byte transferred after the slave address byte with the R/W bit low. Every write operation to the TMP112 requires a value for the Pointer Register (see [Figure 16](#)).

When reading from the TMP112, the last value stored in the Pointer Register by a write operation is used to determine which register is read by a read operation. To change the register pointer for a read operation, a new value must be written to the Pointer Register. This action is accomplished by issuing a slave address byte with the R/W bit low, followed by the Pointer Register byte. No additional data are required. The master can then generate a START condition and send the slave address byte with the R/W bit high to initiate the read command. See [Figure 17](#) for details of this sequence. If repeated

reads from the same register are desired, it is not necessary to continually send the Pointer Register bytes, because the TMP112 remembers the Pointer Register value until it is changed by the next write operation.

Note that register bytes are sent with the most significant byte first, followed by the least significant byte.

SLAVE MODE OPERATIONS

The TMP112 can operate as a slave receiver or slave transmitter. As a slave device, the TMP112 never drives the SCL line.

Slave Receiver Mode:

The first byte transmitted by the master is the slave address, with the R/W bit low. The TMP112 then acknowledges reception of a valid address. The next byte transmitted by the master is the Pointer Register. The TMP112 then acknowledges reception of the Pointer Register byte. The next byte or bytes are written to the register addressed by the Pointer Register. The TMP112 acknowledges reception of each data byte. The master can terminate data transfer by generating a START or STOP condition.

Slave Transmitter Mode:

The first byte transmitted by the master is the slave address, with the R/W bit high. The slave acknowledges reception of a valid slave address. The next byte is transmitted by the slave and is the most significant byte of the register indicated by the Pointer Register. The master acknowledges reception of the data byte. The next byte transmitted by the slave is the least significant byte. The master acknowledges reception of the data byte. The master can terminate data transfer by generating a *Not-Acknowledge* on reception of any data byte, or generating a START or STOP condition.

SMBus ALERT FUNCTION

The TMP112 supports the SMBus Alert function. When the TMP112 operates in Interrupt mode (TM = '1'), the ALERT pin may be connected as an SMBus Alert signal. When a master senses that an ALERT condition is present on the ALERT line, the master sends an SMBus Alert command (00011001) to the bus. If the ALERT pin is active, the device acknowledges the SMBus Alert command and responds by returning its slave address on the SDA line. The eighth bit (LSB) of the slave address byte indicates if the ALERT condition was caused by the temperature exceeding T_{HIGH} or falling below T_{LOW} .

For POL = '0', this bit is low if the temperature is greater than or equal to T_{HIGH} ; this bit is high if the temperature is less than T_{LOW} . The polarity of this bit is inverted if POL = '1'. Refer to [Figure 18](#) for details of this sequence.

If multiple devices on the bus respond to the SMBus Alert command, arbitration during the slave address portion of the SMBus Alert command determines which device clears its ALERT status. The device with the lowest two-wire address wins the arbitration. If the TMP112 wins the arbitration, its ALERT pin becomes inactive at the completion of the SMBus Alert command. If the TMP112 loses the arbitration, its ALERT pin remains active.

GENERAL CALL

The TMP112 responds to a two-wire General Call address (0000000) if the eighth bit is '0'. The device acknowledges the General Call address and responds to commands in the second byte. If the second byte is 00000110, the TMP112 internal registers are reset to power-up values. The TMP112 does not support the General Address acquire command.

HIGH-SPEED (Hs) MODE

In order for the two-wire bus to operate at frequencies above 400kHz, the master device must issue an Hs-mode master code (00001xxx) as the first byte after a START condition to switch the bus to high-speed operation. The TMP112 does not acknowledge this byte, but switches its input filters on SDA and SCL and its output filters on SDA to operate in Hs-mode, allowing transfers at up to 3.4MHz. After the Hs-mode master code has been issued, the master transmits a two-wire slave address to initiate a data transfer operation. The bus continues to operate in Hs-mode until a STOP condition occurs on the bus. Upon receiving the STOP condition, the TMP112 switches the input and output filters back to fast-mode operation.

TIMEOUT FUNCTION

The TMP112 resets the serial interface if SCL is held low for 30ms (typ). The TMP112 releases the bus if it is pulled low and waits for a START condition. To avoid activating the timeout function, it is necessary to maintain a communication speed of at least 1kHz for SCL operating frequency.

NOISE

The TMP112 is a very low-power device and generates very low noise on the supply bus. Applying an RC filter to the V+ pin of the TMP112 can further reduce any noise that the TMP112 might propagate to other components. R_F in Figure 14 should be less than $5k\Omega$ and C_F should be greater than $10nF$.

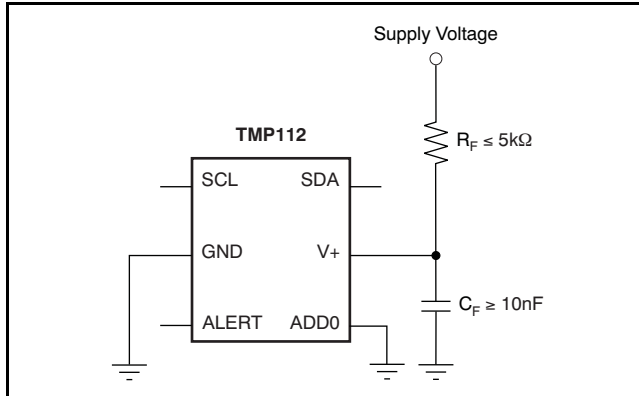

Figure 14. Noise Reduction Techniques

TIMING DIAGRAMS

The TMP112 is two-wire and SMBus compatible. Figure 15 to Figure 18 describe the various operations on the TMP112. Parameters for Figure 15 are defined in Table 13. Bus definitions are:

Bus Idle: Both SDA and SCL lines remain high.

Start Data Transfer: A change in the state of the SDA line, from high to low, while the SCL line is high, defines a START condition. Each data transfer is initiated with a START condition.

Stop Data Transfer: A change in the state of the SDA line from low to high while the SCL line is high defines a STOP condition. Each data transfer is terminated with a repeated START or STOP condition.

Data Transfer: The number of data bytes transferred between a START and a STOP condition is not limited and is determined by the master device. It is also possible to use the TMP112 for single byte updates. To update only the MS byte, terminate the communication by issuing a START or STOP communication on the bus.

Acknowledge: Each receiving device, when addressed, is obliged to generate an Acknowledge bit. A device that acknowledges must pull down the SDA line during the Acknowledge clock pulse in such a way that the SDA line is stable low during the high period of the Acknowledge clock pulse. Setup and hold times must be taken into account. On a master receive, the termination of the data transfer can be signaled by the master generating a *Not-Acknowledge* ('1') on the last byte that has been transmitted by the slave.

Table 13. Timing Diagram Definitions

PARAMETER	TEST CONDITIONS	FAST MODE		HIGH-SPEED MODE		UNIT
		MIN	MAX	MIN	MAX	
$f_{(SCL)}$	SCL Operating Frequency, $V_S > 1.7V$	0.001	0.4	0.001	3.4	MHz
$f_{(SCL)}$	SCL Operating Frequency, $V_S < 1.7V$	0.001	0.4	0.001	2.75	MHz
$t_{(BUF)}$	Bus Free Time Between STOP and START Condition	600		160		ns
$t_{(HDSTA)}$	Hold time after repeated START condition. After this period, the first clock is generated.	100		100		ns
$t_{(SUSTA)}$	Repeated START Condition Setup Time	100		100		ns
$t_{(SUSTO)}$	STOP Condition Setup Time	100		100		ns
$t_{(HDDAT)}$	Data Hold Time	0		0		ns
$t_{(SUDAT)}$	Data Setup Time	100		10		ns
$t_{(LOW)}$	SCL Clock Low Period, $V_S > 1.7V$	1300		160		ns
$t_{(LOW)}$	SCL Clock Low Period, $V_S < 1.7V$	1300		200		ns
$t_{(HIGH)}$	SCL Clock High Period	600		60		ns
t_F	Clock/Data Fall Time		300			ns
t_R	Clock/Data Rise Time		300		160	ns
t_R	Clock/Data Rise Time for $SCLK \leq 100kHz$		1000			ns

[查询TMP112 供应商](#)

TWO-WIRE TIMING DIAGRAMS

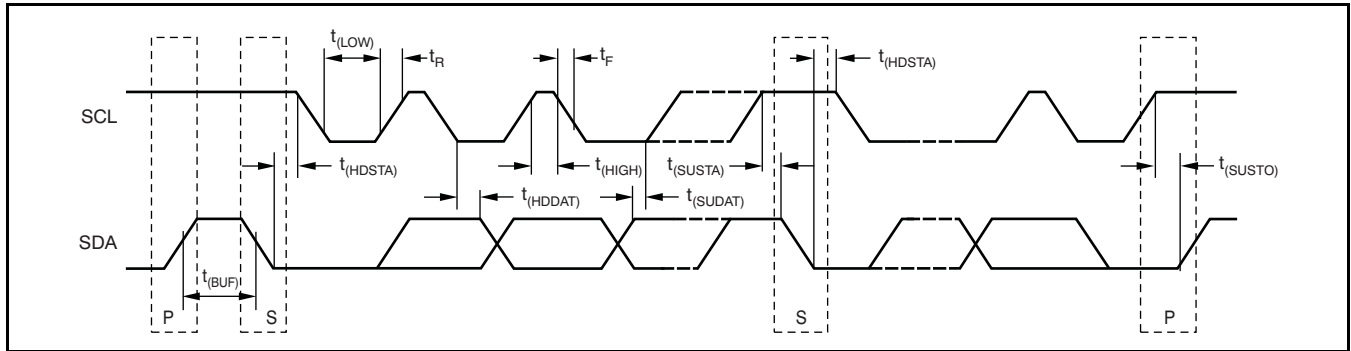

Figure 15. Two-Wire Timing Diagram

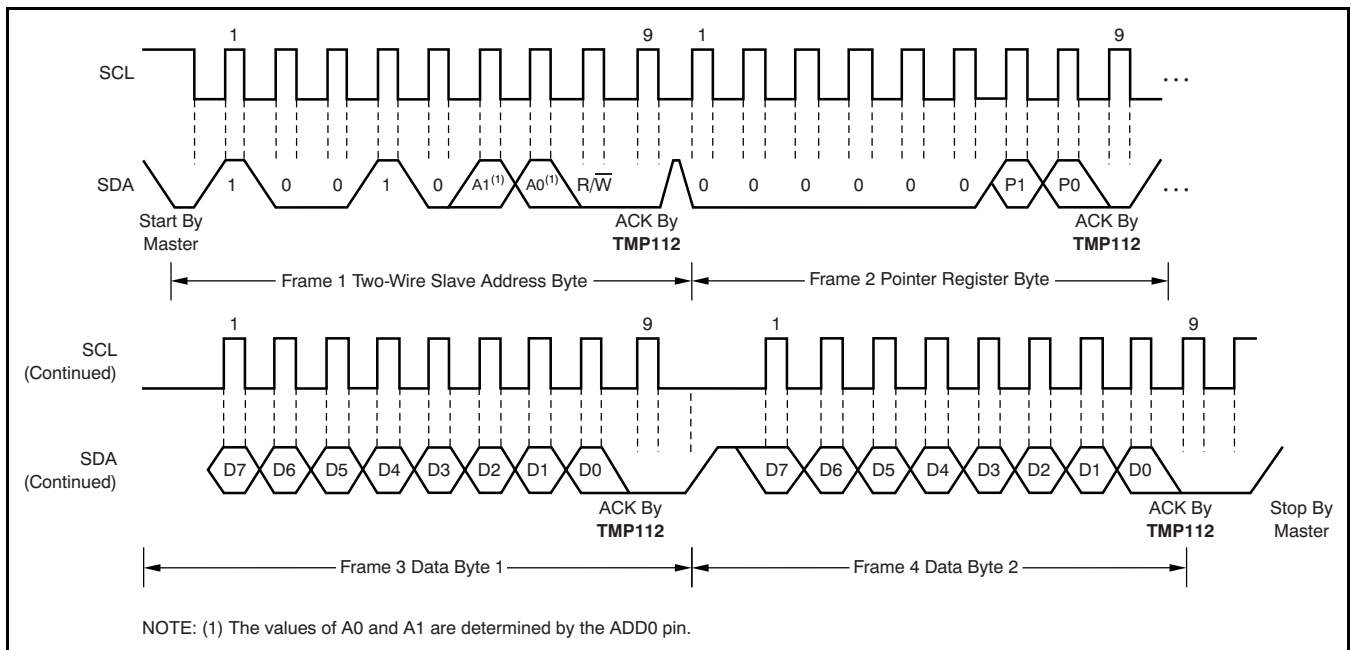

Figure 16. Two-Wire Timing Diagram for Write Word Format

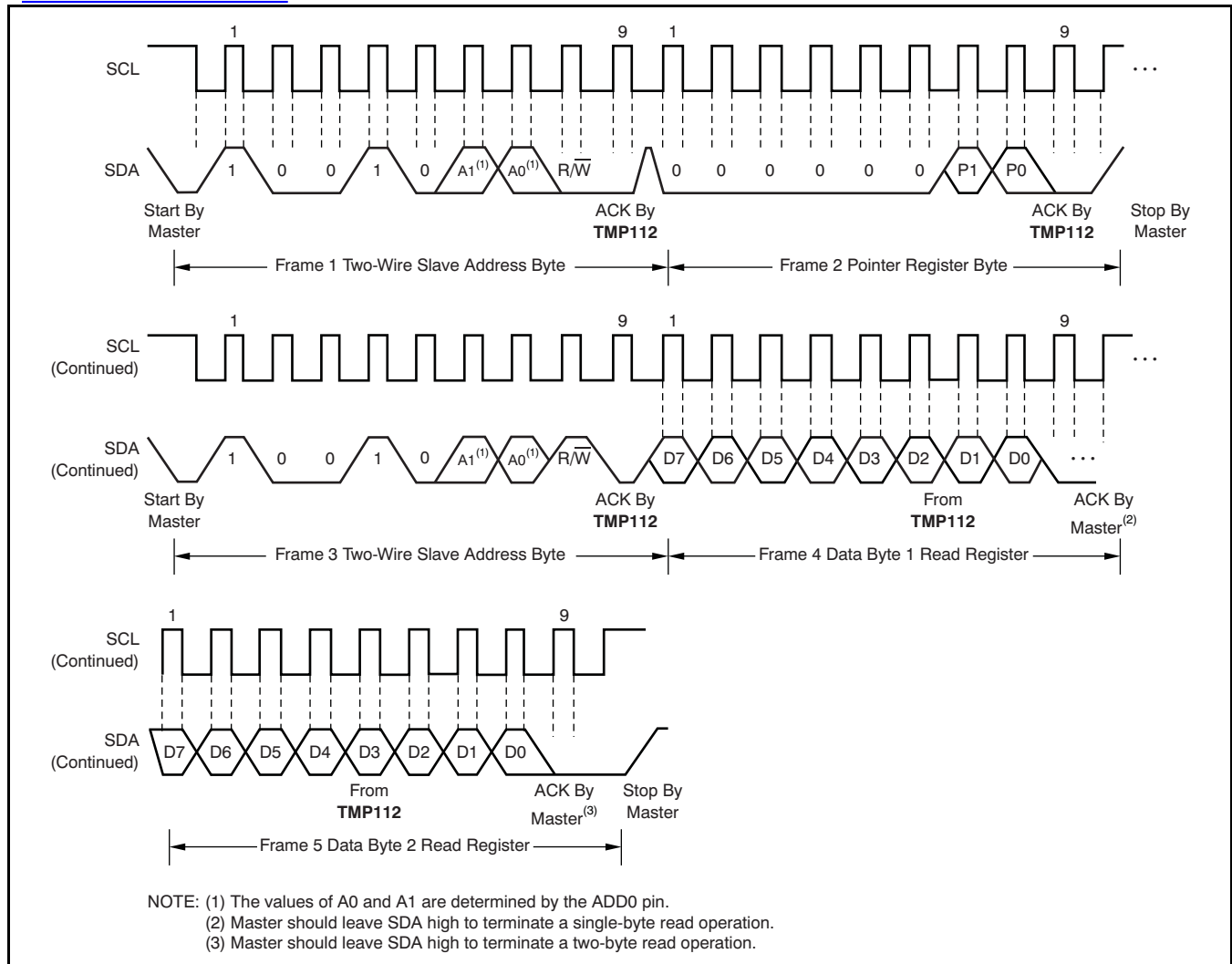

Figure 17. Two-Wire Timing Diagram for Read Word Format

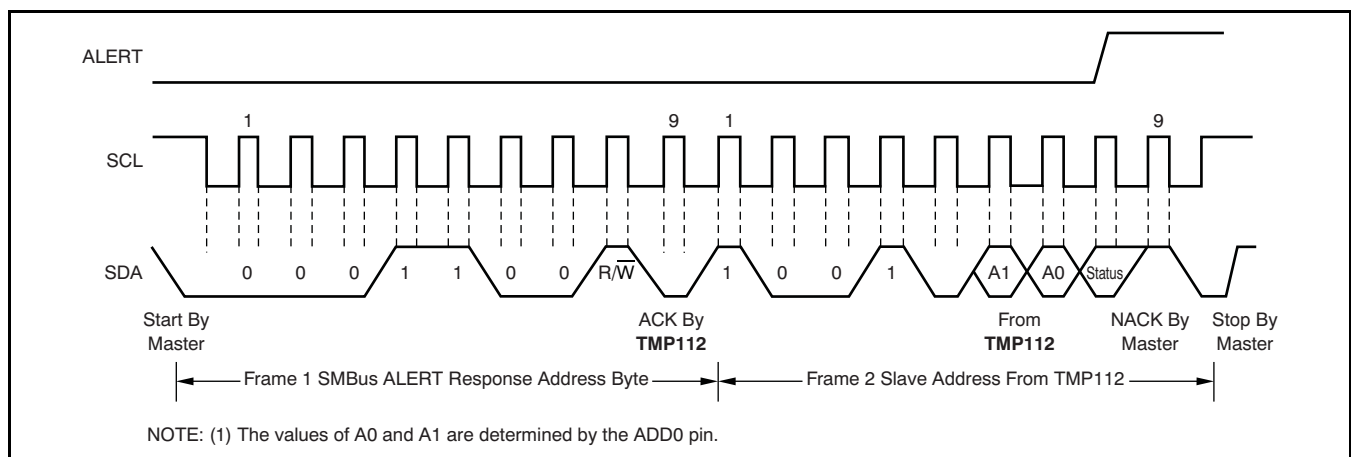

Figure 18. Timing Diagram for SMBus ALERT

[查询TMP112供应商](#)

CALIBRATING FOR IMPROVED ACCURACY

There are many temperature monitoring applications that require better than 0.5°C accuracy over a limited temperature range. Knowing the offset of a temperature sensor at a given temperature in conjunction with the average temperature span (slope) error over a fixed range makes it possible to achieve this improved accuracy.

The TMP112 has three distinct slope regions that conservatively approximate its inherent curvature:

1. Slope1 applies over -40°C to +25°C
2. Slope2 applies over +25°C to +85°C
3. Slope3 applies over +85°C to +125°C

These slopes are defined in [Table 14](#) and shown in [Figure 19](#). It is important to note that each slope is increasing with respect to 25°C.

Table 14. Specifications for User-Calibrated Systems

PARAMETER	CONDITION	MIN	MAX	UNIT
Average Slope (Temperature Error vs Temperature) ⁽¹⁾	V _S = +3.3, -40°C to +25°C	-7	0	m°C/°C
	V _S = +3.3, +25°C to +85°C	0	+5	m°C/°C
	V _S = +3.3, +85°C to +125°C	0	+8	m°C/°C

(1) User-calibrated temperature accuracy can be within ±1LSB because of quantization noise.

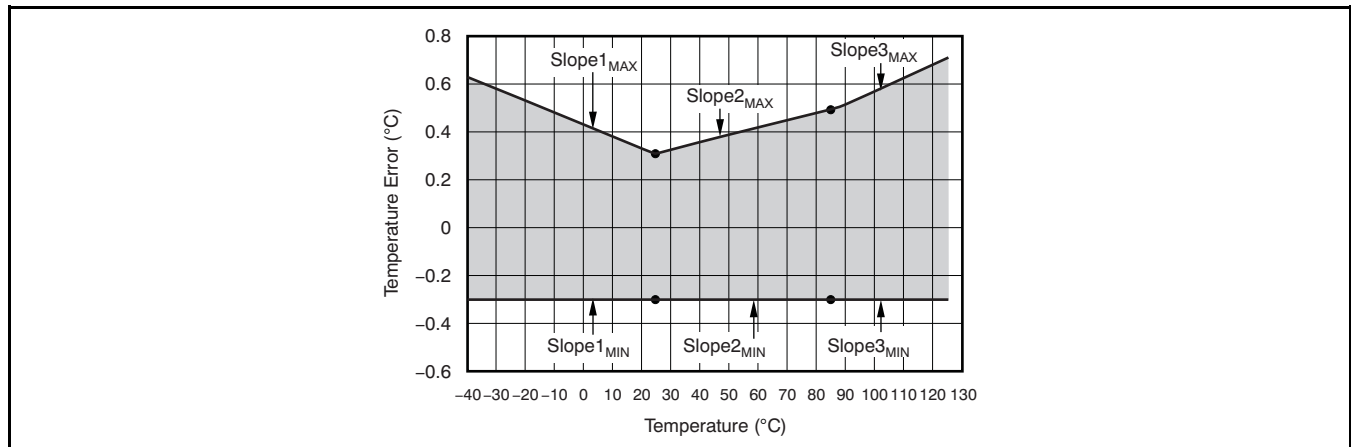

Figure 19. Accuracy and Slope Curves versus Temperature

[Equation 1](#) determines the worst-case accuracy at a specific temperature:

$$\text{Accuracy}_{(\text{worst-case})} = \text{Accuracy}_{(25^\circ\text{C})} + \Delta T \times \text{Slope} \tag{1}$$

EXAMPLE 1: Finding Worst-Case Accuracy From –15°C to +50°C

As an example, if the user is concerned only about the temperature accuracy between –15°C to +50°C, the worst-case accuracy could be determined by using the two slope calculations of [Equation 2](#) and [Equation 4](#):

$$\text{Accuracy}_{\text{MAX}}(-15^{\circ}\text{C to } 25^{\circ}\text{C}) = \text{Accuracy}_{(25^{\circ}\text{C})} + \Delta T \times \text{Slope1}_{\text{MAX}} \quad (2)$$

$$\text{Accuracy}_{\text{MAX}}(-15^{\circ}\text{C to } 25^{\circ}\text{C}) = 0.3^{\circ}\text{C} + (-15^{\circ}\text{C} - 25^{\circ}\text{C}) \left[-7 \frac{\text{m}^{\circ}\text{C}}{^{\circ}\text{C}} \right] = +0.58^{\circ}\text{C} \quad (3)$$

$$\text{Accuracy}_{\text{MAX}}(25^{\circ}\text{C to } 50^{\circ}\text{C}) = \text{Accuracy}_{(25^{\circ}\text{C})} + \Delta T \times \text{Slope2}_{\text{MAX}} \quad (4)$$

$$\text{Accuracy}_{\text{MAX}}(25^{\circ}\text{C to } 50^{\circ}\text{C}) = 0.3^{\circ}\text{C} + (50^{\circ}\text{C} - 25^{\circ}\text{C}) \times \left[5 \frac{\text{m}^{\circ}\text{C}}{^{\circ}\text{C}} \right] = +0.425^{\circ}\text{C} \quad (5)$$

The same calculations must be applied to the minimum case:

$$\text{Accuracy}_{\text{MIN}}(-15^{\circ}\text{C to } 25^{\circ}\text{C}) = \text{Accuracy}_{(25^{\circ}\text{C})} + \Delta T \times \text{Slope1}_{\text{MIN}} \quad (6)$$

$$\text{Accuracy}_{\text{MIN}}(-15^{\circ}\text{C to } 25^{\circ}\text{C}) = -0.5^{\circ}\text{C} + (-15^{\circ}\text{C} - 25^{\circ}\text{C}) \left[0 \frac{\text{m}^{\circ}\text{C}}{^{\circ}\text{C}} \right] = -0.5^{\circ}\text{C} \quad (7)$$

$$\text{Accuracy}_{\text{MIN}}(25^{\circ}\text{C to } 50^{\circ}\text{C}) = \text{Accuracy}_{(25^{\circ}\text{C})} + \Delta T \times \text{Slope2}_{\text{MIN}} \quad (8)$$

$$\text{Accuracy}_{\text{MIN}}(25^{\circ}\text{C to } 50^{\circ}\text{C}) = -0.5^{\circ}\text{C} + (50^{\circ}\text{C} - 25^{\circ}\text{C}) \left[0 \frac{\text{m}^{\circ}\text{C}}{^{\circ}\text{C}} \right] = -0.5^{\circ}\text{C} \quad (9)$$

Based on the above calculations, a user can expect a worst-case accuracy of +0.58°C to –0.5°C in the temperature range of –15°C to +50°C.

EXAMPLE 2: Finding Worst-Case Accuracy From +25°C to +100°C

If the desired temperature range falls in the region of slope 3, it is necessary to first calculate the worst-case value from +25°C to +85°C and add it to the change in temperature multiplied by the span error of slope 3. As an example, consider the temperature range of +25°C to +125°C as shown in [Equation 10](#):

$$\text{Accuracy}_{\text{MAX}}(25^{\circ}\text{C to } 100^{\circ}\text{C}) = \text{Accuracy}_{(25^{\circ}\text{C})} + \Delta T \times \text{Slope2}_{\text{MAX}} + \Delta T \times \text{Slope3}_{\text{MAX}} \quad (10)$$

$$\text{Accuracy}_{\text{MAX}}(25^{\circ}\text{C to } 100^{\circ}\text{C}) = 0.3^{\circ}\text{C} + (85^{\circ}\text{C} - 25^{\circ}\text{C}) \left[4.5 \frac{\text{m}^{\circ}\text{C}}{^{\circ}\text{C}} \right] + (100^{\circ}\text{C} - 85^{\circ}\text{C}) \left[8 \frac{\text{m}^{\circ}\text{C}}{^{\circ}\text{C}} \right] = +0.690^{\circ}\text{C} \quad (11)$$

Performing the same calculation for the minimum case is shown in [Equation 12](#):

$$\text{Accuracy}_{\text{MIN}}(25^{\circ}\text{C to } 100^{\circ}\text{C}) = \text{Accuracy}_{(25^{\circ}\text{C})} + \Delta T \times \text{Slope2}_{\text{MIN}} + \Delta T \times \text{Slope3}_{\text{MIN}} \quad (12)$$

$$\text{Accuracy}_{\text{MIN}}(25^{\circ}\text{C to } 100^{\circ}\text{C}) = -0.5^{\circ}\text{C} + (85^{\circ}\text{C} - 25^{\circ}\text{C}) \left[0 \frac{\text{m}^{\circ}\text{C}}{^{\circ}\text{C}} \right] + (100^{\circ}\text{C} - 85^{\circ}\text{C}) \left[0 \frac{\text{m}^{\circ}\text{C}}{^{\circ}\text{C}} \right] = -0.5^{\circ}\text{C} \quad (13)$$

查询TMP112供应商

USING THE SLOPE SPECIFICATIONS WITH A 1-POINT CALIBRATION

The initial accuracy assurance at +25°C with the slope regions provides an accuracy that is high enough for most applications; however, if higher accuracy is desired, this increase can be achieved with a 1-point calibration at +25°C. This calibration removes the offset at room temperature, thereby reducing the source of error in a TMP112 temperature reading down to the curvature. Figure 20 shows the error of a calibrated TMP112.

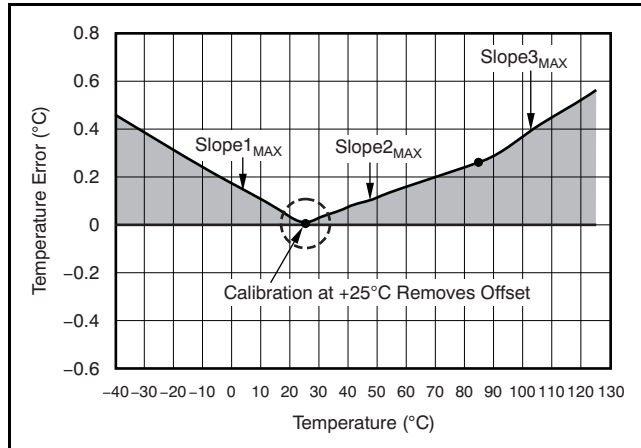

Figure 20. Calibrated Accuracy and Slope Curves versus Temperature

Using the previous example temperature range of 0°C to +50°C, the worst-case temperature error is now reduced to the worst-case slopes because the offset at +25°C (that is, the maximum and minimum temperature errors of +0.3°C and -0.5°C) is removed. Therefore, a user can expect the worst-case accuracy to improve to +0.175°C.

Power-Supply Level Contribution to Accuracy

The superior accuracy that can be achieved with the TMP112 is complemented by its immunity to dc variations from a 3.3V supply voltage. This immunity is important because it spares the user from having to use another LDO to produce 3.3V to achieve accuracy. Nevertheless, the noise quantization that results from changing supply can add some slight change in temperature measurement accuracy. As an example, if the user chooses to operate at 1.8V, the worst-case expected change in accuracy can be calculated by Equation 14:

$$\text{Accuracy}_{\text{PSR}} = \pm(V_S - 3.3V) \times \left[\frac{+0.250^\circ\text{C}}{V} \right] \tag{14}$$

$$\text{Accuracy}_{\text{PSR}} = \pm(1.8V - 3.3V) \times \left[\frac{+0.250^\circ\text{C}}{V} \right] = +0.375^\circ\text{C} \tag{15}$$

This example is a worst-case accuracy contribution as a result of variation in power supply that should be added to the accuracy + slope maximum.

Revision History

NOTE: Page numbers for previous revisions may differ from page numbers in the current version.

Changes from Revision A (March 2009) to Revision B	Page
• Changed footnote 1 of Table 14	16
• Clarified Example 1; extended worst-case accuracy to be from -15°C to $+50^{\circ}\text{C}$	17
• Corrected Equation 15	18

PACKAGING INFORMATION

Orderable Device	Status ⁽¹⁾	Package Type	Package Drawing	Pins	Package Qty	Eco Plan ⁽²⁾	Lead/Ball Finish	MSL Peak Temp ⁽³⁾
TMP112AIDRLR	ACTIVE	SOT	DRL	6	4000	Green (RoHS & no Sb/Br)	CU NIPDAU	Level-1-260C-UNLIM
TMP112AIDRLT	ACTIVE	SOT	DRL	6	250	Green (RoHS & no Sb/Br)	CU NIPDAU	Level-1-260C-UNLIM

⁽¹⁾ The marketing status values are defined as follows:

ACTIVE: Product device recommended for new designs.

LIFEBUY: TI has announced that the device will be discontinued, and a lifetime-buy period is in effect.

NRND: Not recommended for new designs. Device is in production to support existing customers, but TI does not recommend using this part in a new design.

PREVIEW: Device has been announced but is not in production. Samples may or may not be available.

OBsolete: TI has discontinued the production of the device.

⁽²⁾ Eco Plan - The planned eco-friendly classification: Pb-Free (RoHS), Pb-Free (RoHS Exempt), or Green (RoHS & no Sb/Br) - please check <http://www.ti.com/productcontent> for the latest availability information and additional product content details.

TBD: The Pb-Free/Green conversion plan has not been defined.

Pb-Free (RoHS): TI's terms "Lead-Free" or "Pb-Free" mean semiconductor products that are compatible with the current RoHS requirements for all 6 substances, including the requirement that lead not exceed 0.1% by weight in homogeneous materials. Where designed to be soldered at high temperatures, TI Pb-Free products are suitable for use in specified lead-free processes.

Pb-Free (RoHS Exempt): This component has a RoHS exemption for either 1) lead-based flip-chip solder bumps used between the die and package, or 2) lead-based die adhesive used between the die and leadframe. The component is otherwise considered Pb-Free (RoHS compatible) as defined above.

Green (RoHS & no Sb/Br): TI defines "Green" to mean Pb-Free (RoHS compatible), and free of Bromine (Br) and Antimony (Sb) based flame retardants (Br or Sb do not exceed 0.1% by weight in homogeneous material)

⁽³⁾ MSL, Peak Temp. -- The Moisture Sensitivity Level rating according to the JEDEC industry standard classifications, and peak solder temperature.

Important Information and Disclaimer:The information provided on this page represents TI's knowledge and belief as of the date that it is provided. TI bases its knowledge and belief on information provided by third parties, and makes no representation or warranty as to the accuracy of such information. Efforts are underway to better integrate information from third parties. TI has taken and continues to take reasonable steps to provide representative and accurate information but may not have conducted destructive testing or chemical analysis on incoming materials and chemicals. TI and TI suppliers consider certain information to be proprietary, and thus CAS numbers and other limited information may not be available for release.

In no event shall TI's liability arising out of such information exceed the total purchase price of the TI part(s) at issue in this document sold by TI to Customer on an annual basis.

TAPE AND REEL INFORMATION

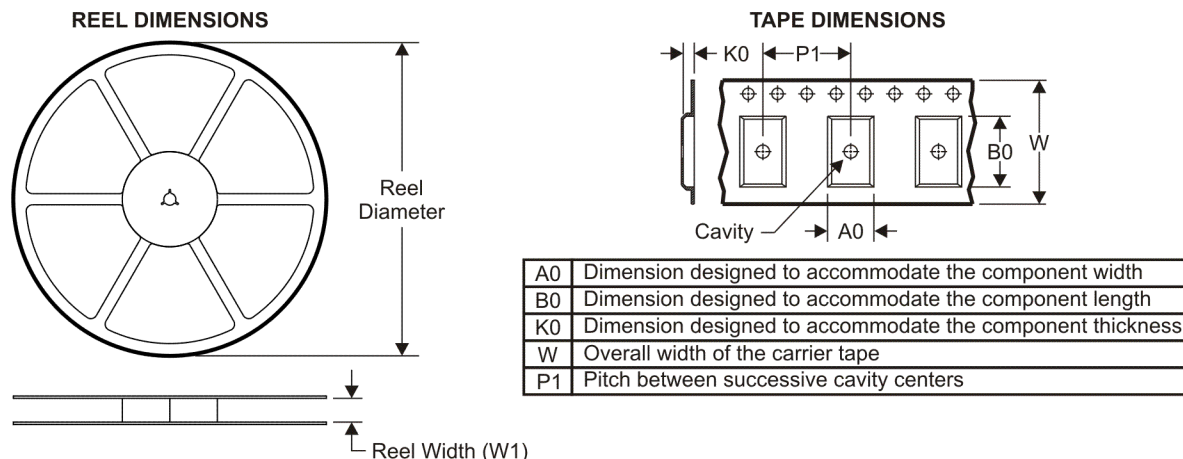

QUADRANT ASSIGNMENTS FOR PIN 1 ORIENTATION IN TAPE



*All dimensions are nominal

Device	Package Type	Package Drawing	Pins	SPQ	Reel Diameter (mm)	Reel Width W1 (mm)	A0 (mm)	B0 (mm)	K0 (mm)	P1 (mm)	W (mm)	Pin1 Quadrant
TMP112AIDRLR	SOT	DRL	6	4000	180.0	8.4	1.78	1.78	0.69	4.0	8.0	Q3
TMP112AIDRLT	SOT	DRL	6	250	180.0	8.4	1.78	1.78	0.69	4.0	8.0	Q3

TAPE AND REEL BOX DIMENSIONS



*All dimensions are nominal

Device	Package Type	Package Drawing	Pins	SPQ	Length (mm)	Width (mm)	Height (mm)
TMP112AIDRLR	SOT	DRL	6	4000	202.0	201.0	28.0
TMP112AIDRLT	SOT	DRL	6	250	202.0	201.0	28.0

DRL (R-PDSO-N6)

PLASTIC SMALL OUTLINE

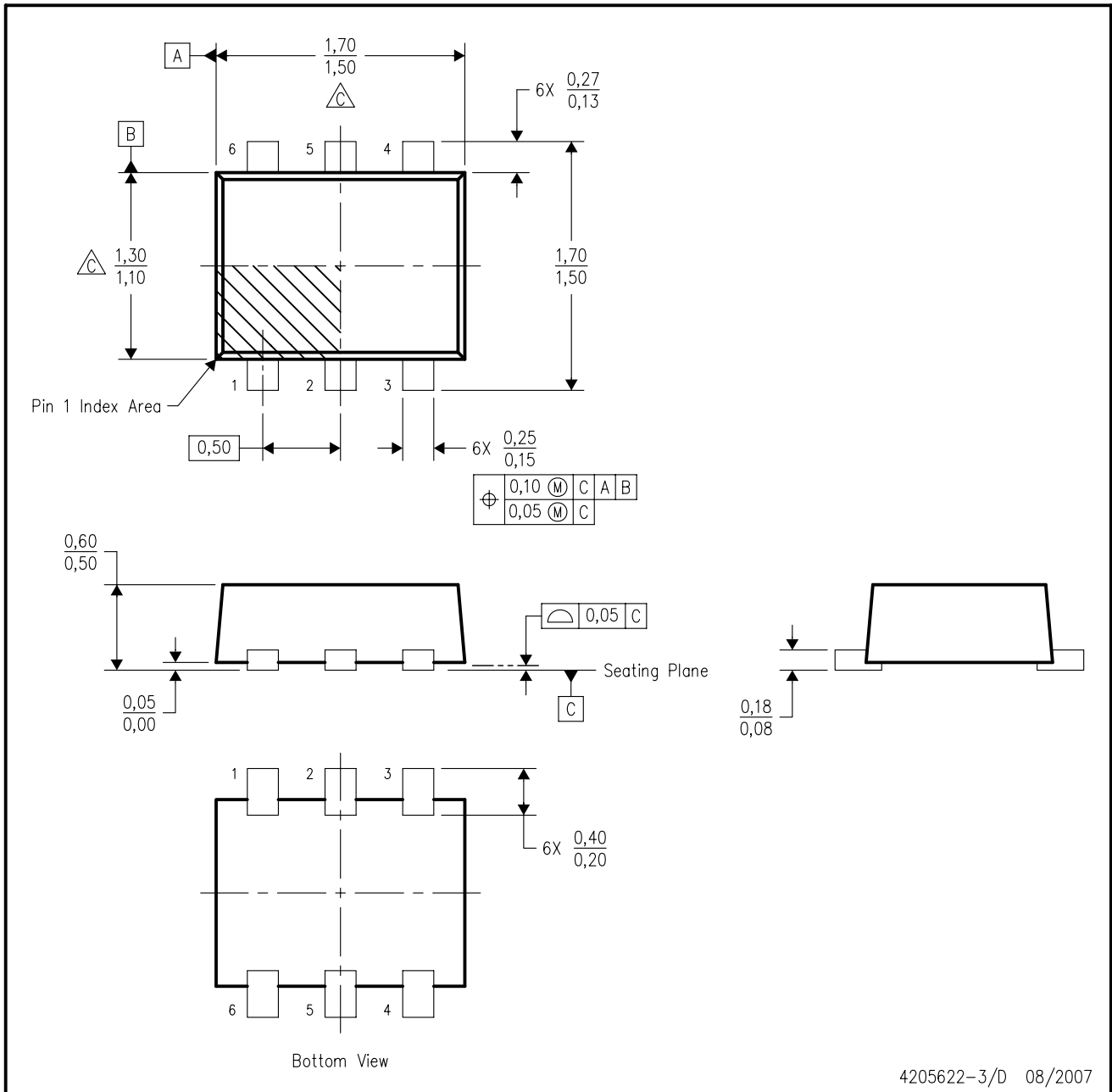

4205622-3/D 08/2007

- NOTES:
- A. All linear dimensions are in millimeters. Dimensioning and tolerancing per ASME Y14.5M-1994.
 - B. This drawing is subject to change without notice.
 - C. Body dimensions do not include mold flash, interlead flash, protrusions, or gate burrs. Mold flash, interlead flash, protrusions, or gate burrs shall not exceed 0,15 per end or side.
 - D. JEDEC package registration is pending.

[查询"TMP112"供应商](#)

DRL (R-PDSO-N6)

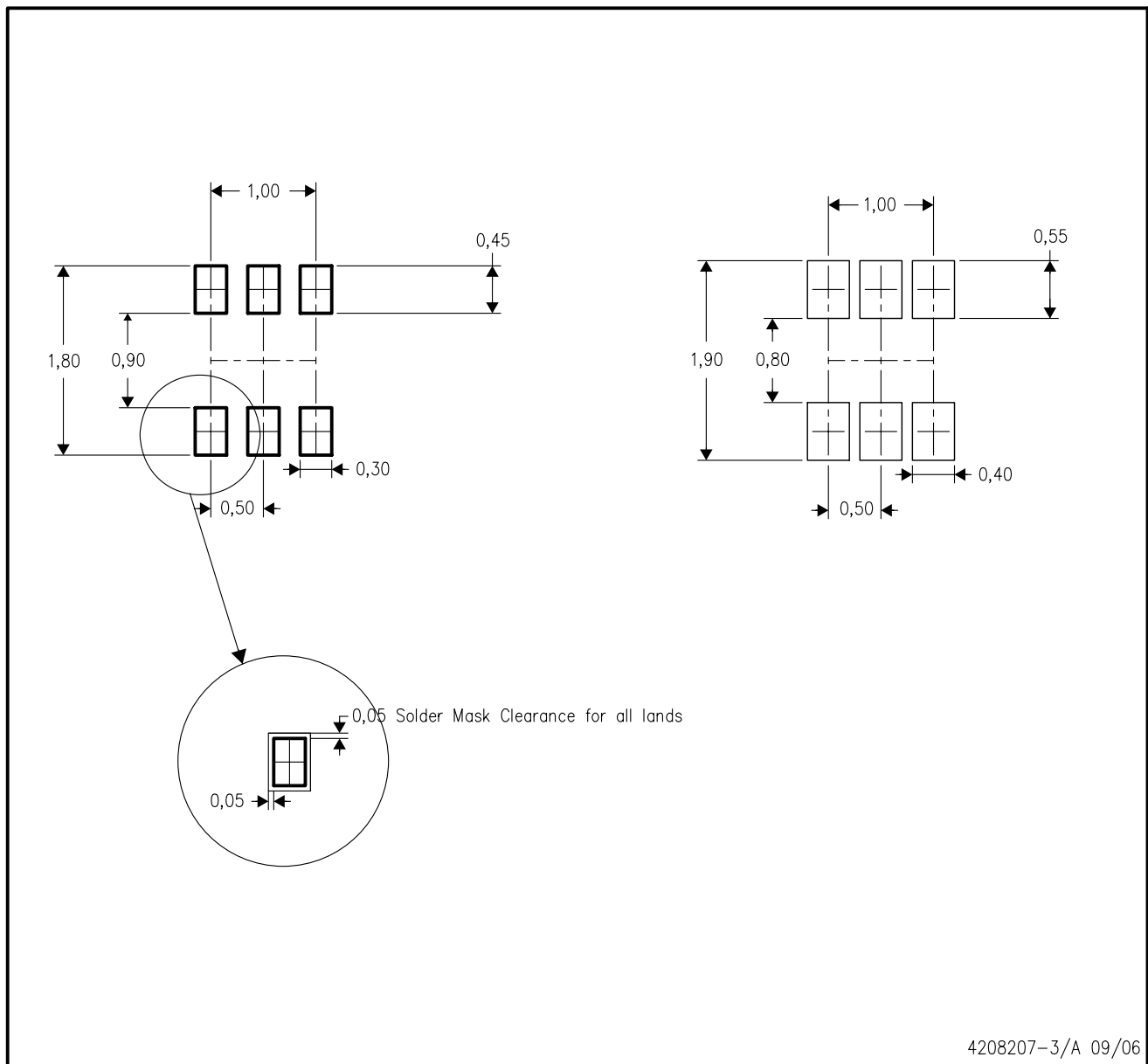

- NOTES:
- All linear dimensions are in millimeters.
 - This drawing is subject to change without notice.
 - Publication IPC-7351 is recommended for alternate designs.
 - Customers should contact their board fabrication site for minimum solder mask web tolerances between signal pads.
 - Maximum stencil thickness 0,127 mm (5 mils). All linear dimensions are in millimeters.
 - Laser cutting apertures with trapezoidal walls and also rounding corners will offer better paste release. Customers should contact their board assembly site for stencil design recommendations. Refer to IPC 7525 for stencil design considerations.
 - Side aperture dimensions over-print land for acceptable area ratio > 0.66. Customer may reduce side aperture dimensions if stencil manufacturing process allows for sufficient release at smaller opening.

IMPORTANT NOTICE

Texas Instruments Incorporated and its subsidiaries (TI) reserve the right to make corrections, modifications, enhancements, improvements, and other changes to its products and services at any time and to discontinue any product or service without notice. Customers should obtain the latest relevant information before placing orders and should verify that such information is current and complete. All products are sold subject to TI's terms and conditions of sale supplied at the time of order acknowledgment.

TI warrants performance of its hardware products to the specifications applicable at the time of sale in accordance with TI's standard warranty. Testing and other quality control techniques are used to the extent TI deems necessary to support this warranty. Except where mandated by government requirements, testing of all parameters of each product is not necessarily performed.

TI assumes no liability for applications assistance or customer product design. Customers are responsible for their products and applications using TI components. To minimize the risks associated with customer products and applications, customers should provide adequate design and operating safeguards.

TI does not warrant or represent that any license, either express or implied, is granted under any TI patent right, copyright, mask work right, or other TI intellectual property right relating to any combination, machine, or process in which TI products or services are used. Information published by TI regarding third-party products or services does not constitute a license from TI to use such products or services or a warranty or endorsement thereof. Use of such information may require a license from a third party under the patents or other intellectual property of the third party, or a license from TI under the patents or other intellectual property of TI.

Reproduction of TI information in TI data books or data sheets is permissible only if reproduction is without alteration and is accompanied by all associated warranties, conditions, limitations, and notices. Reproduction of this information with alteration is an unfair and deceptive business practice. TI is not responsible or liable for such altered documentation. Information of third parties may be subject to additional restrictions.

Resale of TI products or services with statements different from or beyond the parameters stated by TI for that product or service voids all express and any implied warranties for the associated TI product or service and is an unfair and deceptive business practice. TI is not responsible or liable for any such statements.

TI products are not authorized for use in safety-critical applications (such as life support) where a failure of the TI product would reasonably be expected to cause severe personal injury or death, unless officers of the parties have executed an agreement specifically governing such use. Buyers represent that they have all necessary expertise in the safety and regulatory ramifications of their applications, and acknowledge and agree that they are solely responsible for all legal, regulatory and safety-related requirements concerning their products and any use of TI products in such safety-critical applications, notwithstanding any applications-related information or support that may be provided by TI. Further, Buyers must fully indemnify TI and its representatives against any damages arising out of the use of TI products in such safety-critical applications.

TI products are neither designed nor intended for use in military/aerospace applications or environments unless the TI products are specifically designated by TI as military-grade or "enhanced plastic." Only products designated by TI as military-grade meet military specifications. Buyers acknowledge and agree that any such use of TI products which TI has not designated as military-grade is solely at the Buyer's risk, and that they are solely responsible for compliance with all legal and regulatory requirements in connection with such use.

TI products are neither designed nor intended for use in automotive applications or environments unless the specific TI products are designated by TI as compliant with ISO/TS 16949 requirements. Buyers acknowledge and agree that, if they use any non-designated products in automotive applications, TI will not be responsible for any failure to meet such requirements.

Following are URLs where you can obtain information on other Texas Instruments products and application solutions:

Products		Applications	
Amplifiers	amplifier.ti.com	Audio	www.ti.com/audio
Data Converters	dataconverter.ti.com	Automotive	www.ti.com/automotive
DLP® Products	www.dlp.com	Communications and Telecom	www.ti.com/communications
DSP	dsp.ti.com	Computers and Peripherals	www.ti.com/computers
Clocks and Timers	www.ti.com/clocks	Consumer Electronics	www.ti.com/consumer-apps
Interface	interface.ti.com	Energy	www.ti.com/energy
Logic	logic.ti.com	Industrial	www.ti.com/industrial
Power Mgmt	power.ti.com	Medical	www.ti.com/medical
Microcontrollers	microcontroller.ti.com	Security	www.ti.com/security
RFID	www.ti-rfid.com	Space, Avionics & Defense	www.ti.com/space-avionics-defense
RF/IF and ZigBee® Solutions	www.ti.com/lprf	Video and Imaging	www.ti.com/video
		Wireless	www.ti.com/wireless-apps