

FEMTOCLOCK™ CRYSTAL-TO-HCSL CLOCK GENERATOR

ICS841664I

GENERAL DESCRIPTION



The ICS841664I is an optimized sRIO clock generator and member of the HiPerClocks™ family of high-performance clock solutions from IDT. The device uses a 25MHz parallel crystal to generate 125MHz and 156.25MHz clock signals, replacing solutions requiring multiple oscillator and fanout buffer solutions. The device has excellent phase jitter (< 1ps rms) suitable to clock components requiring precise and low-jitter sRIO clock signals. Designed for telecom, networking and industrial applications, the ICS841664I can also drive the high-speed sRIO SerDes clock inputs of communication processors, DSPs, switches and bridges.

FEATURES

- Four differential HCSL clock outputs: configurable for sRIO (125MHz or 156.25MHz) clock signals
One REF_OUT LVCMOS/LVTTL clock output
- Selectable crystal oscillator interface, 25MHz, 18pF parallel resonant crystal or LVCMOS/LVTTL single-ended reference clock input
- Supports the following output frequencies:
125MHz or 156.25MHz
- VCO: 625MHz
- PLL bypass and output enable
- RMS phase jitter, using a 25MHz crystal (1.875MHz - 20MHz):
0.35ps (typical) @ 125MHz
- Full 3.3V power supply mode
- -40°C to 85°C ambient operating temperature
- Available in both standard (RoHS 5) and lead-free (RoHS 6) packages

BLOCK DIAGRAM

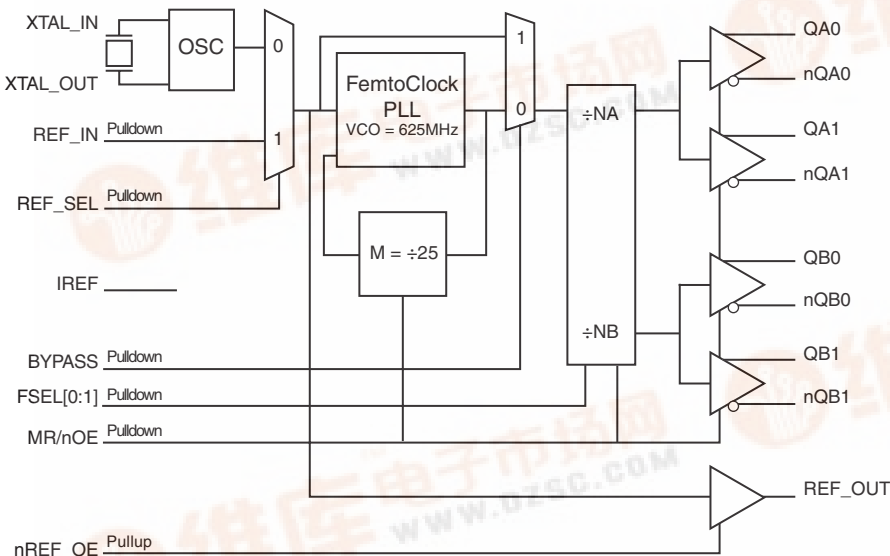

PIN ASSIGNMENT

V _{DD}	1	28	IREF
REF_OUT	2	27	FSELO
GND	3	26	FSEL1
QA0	4	25	QB0
nQA0	5	24	nQB0
V _{DDA}	6	23	V _{DDOB}
GND	7	22	GND
QA1	8	21	QB1
nQA1	9	20	nQB1
nREF_OE	10	19	MR/nOE
BYPASS	11	18	V _{DD}
REF_IN	12	17	XTAL_IN
REF_SEL	13	16	XTAL_OUT
V _{DDA}	14	15	GND

ICS841664I

28-Lead TSSOP

6.1mm x 9.7mm x 0.925mm
package body
G Package
Top View

The Preliminary Information presented herein represents a product in pre-production. The noted characteristics are based on initial product characterization and/or qualification. Integrated Device Technology, Incorporated (IDT) reserves the right to change any circuitry or specifications without notice.



[查询"841664AGILF"供应商](#)

TABLE 1. PIN DESCRIPTIONS

Number	Name	Type		Description
1, 18	V _{DD}	Power		Core supply pins.
2	REF_OUT	Output		LVC MOS/LVTTL reference frequency clock output.
3, 7, 15, 22	GND	Power		Power supply ground.
4, 5, 8, 9	QA0, nQA0, QA1, nQA1	Output		Differential Bank A output pairs. HCSL interface levels.
6	V _{DDOA}	Power		Output supply pin for Bank A outputs.
10	nREF_OE	Input	Pullup	Active low REF_OUT enable/disable. See Table 3E. LVC MOS/LVTTL interface levels.
11	BYPASS	Input	Pulldown	Selects PLL operation/PLL bypass operation. See Table 3C. LVC MOS/LVTTL interface levels.
12	REF_IN	Input	Pulldown	LVC MOS/LVTTL PLL reference clock input.
13	REF_SEL	Input	Pulldown	Reference select. Selects the input reference source. See Table 3B. LVC MOS/LVTTL interface levels.
14	V _{DDA}	Power		Analog supply pin.
16, 17	XTAL_OUT, XTAL_IN	Input		Parallel resonant crystal interface. XTAL_OUT is the output, XTAL_IN is the input. (PLL reference.)
19	MR/nOE	Input	Pulldown	Active HIGH master reset. Active LOW output enable. When logic HIGH, the internal dividers are reset and the outputs are in high impedance (HiZ). When logic LOW, the internal dividers and the outputs are enabled. See Table 3D. LVC MOS/LVTTL interface levels.
20, 21 24, 25	nQB1, QB1 nQB0, QB0	Output		Differential Bank B output pairs. HCSL interface levels.
23	V _{DDOB}	Power		Output supply pin for Bank B outputs.
26, 27	FSEL1, FSEL0	Input	Pulldown	Output frequency select pins. LVC MOS/LVTTL interface levels.
28	IREF	Output		HCSL current reference resistor output. A fixed precision resistor (475Ω) from this pin to ground provides a reference current used for differential current-mode QXx/nQXx clock outputs.

NOTE: *Pullup* and *Pulldown* refer to internal input resistors. See Table 2, Pin Characteristics, for typical values.

TABLE 2. PIN CHARACTERISTICS

Symbol	Parameter	Test Conditions	Minimum	Typical	Maximum	Units
C _{IN}	Input Capacitance			4		pF
C _{PD}	Power Dissipation Capacitance	V _{DD} , V _{DDOA} , V _{DDOB} = 3.465V		18		pF
R _{PULLUP}	Input Pullup Resistor			51		kΩ
R _{PULLDOWN}	Input Pulldown Resistor			51		kΩ

[查询"841664AGILF"供应商](#)

TABLE 3A. FSELx FUNCTION TABLE ($f_{ref} = 25\text{MHz}$)

Inputs			Outputs Frequency Settings	
FSEL1	FSEL0	M	QA0:1/nQA0:1	QB0:1/nQB0:1
0	0	25	VCO/5 (125MHz)	VCO/5 (125MHz)
0	1	25	VCO/5 (125MHz)	VCO/4 (156.25MHz)
1	0	25	VCO/5 (125MHz)	QB0:1 = L, nQB0:1 = H
1	1	25	VCO/4 (156.25MHz)	VCO/4 (156.25MHz)

TABLE 3B. REF_SEL FUNCTION TABLE

Input	
REF_SEL	Input Reference
0	XTAL
1	REF_IN

TABLE 3C. BYPASS FUNCTION TABLE

Input	
BYPASS	PLL Configuration
0	PLL on
1	PLL bypassed (QA, QB = f_{ref}/N)

NOTE 1: Asynchr. function (may cause output glitch).

TABLE 3D. MR/nOE FUNCTION TABLE

Input	
MR/nOE	Function ^{NOTE 1}
0	Outputs enabled
1	Device reset, outputs disabled (Low)

NOTE 1: Asynchr. function (may cause output glitch).

TABLE 3E. nREF_OE FUNCTION TABLE

Input	
nREF_OE	Function ^{NOTE 1}
0	REF_OUT enabled
1	REF_OUT disabled (high impedance)

NOTE 1: Asynchr. function (may cause output glitch).

[查询"841664AGILF"供应商](#)

ABSOLUTE MAXIMUM RATINGS

Supply Voltage, V_{DD}	4.6V
Inputs, V_I	-0.5V to $V_{DD} + 0.5V$
Outputs, V_O	-0.5V to $V_{DDO_X} + 0.5V$
Package Thermal Impedance, θ_{JA}	64.5°C/W (0 mps)
Storage Temperature, T_{STG}	-65°C to 150°C

NOTE: Stresses beyond those listed under Absolute Maximum Ratings may cause permanent damage to the device. These ratings are stress specifications only. Functional operation of product at these conditions or any conditions beyond those listed in the *DC Characteristics* or *AC Characteristics* is not implied. Exposure to absolute maximum rating conditions for extended periods may affect product reliability.

TABLE 4A. POWER SUPPLY DC CHARACTERISTICS, $V_{DD} = V_{DDOA} = V_{DDOB} = 3.3V \pm 5\%$, $T_A = -40^\circ C$ TO $85^\circ C$

Symbol	Parameter	Test Conditions	Minimum	Typical	Maximum	Units
V_{DD}	Core Supply Voltage		3.135	3.3	3.465	V
V_{DDA}	Analog Supply Voltage		$V_{DD} - 0.15$	3.3	3.465	V
V_{DDOA} , V_{DDOB}	Output Supply Voltage		3.135	3.3	3.465	V
I_{DD}	Power Supply Current			70		mA
I_{DDA}	Analog Supply Current			15		mA
I_{DDOA} , I_{DDOB}	Output Supply Current			75		mA

TABLE 4B. LVCMOS / LVTTTL DC CHARACTERISTICS, $V_{DD} = 3.3V \pm 5\%$, $T_A = -40^\circ C$ TO $85^\circ C$

Symbol	Parameter	Test Conditions	Minimum	Typical	Maximum	Units
V_{IH}	Input High Voltage		2		$V_{DD} + 0.3$	V
V_{IL}	Input Low Voltage		-0.3		0.8	V
I_{IH}	Input High Current	REF_IN, REF_SEL, BYPASS, MR/nOE, FSEL0, FSEL1	$V_{DD} = V_{IN} = 3.465 V$		150	μA
		nREF_OE	$V_{DD} = V_{IN} = 3.465V$		5	μA
I_{IL}	Input Low Current	REF_IN, REF_SEL, BYPASS, MR/nOE, FSEL0, FSEL1	$V_{DD} = 3.465V, V_{IN} = 0V$	-5		μA
		nREF_OE	$V_{DD} = 3.465V, V_{IN} = 0V$	-150		μA
V_{OH}	Output High Voltage; NOTE 1	REF_OUT	$V_{DD} = 3.465V$	2.275		V
V_{OL}	Output Low Voltage; NOTE 1	REF_OUT	$V_{DD} = 3.465V$		0.775	V
Z_{OUT}	Output Impedance	REF_OUT	$V_{DD} = 3.465V$	20		Ω

NOTE 1: Outputs terminated with 50 Ω to $V_{DD}/2$. See Parameter Measurement Information Section, *Output Load Test Circuit diagram*.

[查询"841664AGILF"供应商](#)

TABLE 5. CRYSTAL CHARACTERISTICS

Parameter	Test Conditions	Minimum	Typical	Maximum	Units
Mode of Oscillation		Fundamental			
Frequency			25		MHz
Equivalent Series Resistance (ESR)				50	Ω
Shunt Capacitance				7	pF
Drive Level				0.1	mW

NOTE: Characterized using an 18pF parallel resonant crystal.

TABLE 6A. LVC MOS AC CHARACTERISTICS, $V_{DD} = 3.3V \pm 5\%$, $T_A = -40^\circ\text{C}$ TO 85°C

Symbol	Parameter	Test Conditions	Minimum	Typical	Maximum	Units
f_{MAX}	Output Frequency	REF_OUT		25		MHz
t_R / t_F	Output Rise/Fall Time	20% to 80%		1		ns
odc	Output Duty Cycle			50		%

TABLE 6B. HCSL AC CHARACTERISTICS, $V_{DD} = V_{DDOA} = V_{DDOB} = 3.3V \pm 5\%$, $T_A = -40^\circ\text{C}$ TO 85°C

Symbol	Parameter	Test Conditions	Minimum	Typical	Maximum	Units	
f_{MAX}	Output Frequency	VCO/5		125		MHz	
		VCO/4		156.25		MHz	
$f_{jit}(\emptyset)$	RMS Phase Jitter (Random); NOTE 1	125MHz, (1.875MHz - 20MHz)		0.35		ps	
		156.25MHz, (1.875MHz - 20MHz)		0.35		ps	
$t_{sk}(o)$	Output Skew; NOTE 2, 3	QAx/nQAx, QBx/nQBx				ps	
t_L	PLL Lock Time				1	ms	
V_{HIGH}	Voltage High		660	700	850	mV	
V_{LOW}	Voltage Low		-150		150	mV	
V_{OVS}	Max. Voltage, Overshoot		0.3		0.3	V	
V_{UDS}	Min. Voltage, Undershoot		-0.3		-0.3	V	
V_{rb}	Ringback Voltage		0.2			V	
V_{CROSS}	Absolute Crossing Voltage		250		550	mV	
ΔV_{CROSS}	Total Variation of V_{CROSS} over all edges				140	mV	
t_R / t_F	Output Rise/Fall Time	QAx/nQAx, QBx/nQBx	measured between 0.175V to 0.525V			350	ps
$\Delta t_R / \Delta t_F$	Rise/Fall Time Variation				125	ps	
odc	Output Duty Cycle	QAx/nQAx, QBx/nQBx		50		%	

NOTE: Electrical parameters are guaranteed over the specified ambient operating temperature range, which is established when the device is mounted in a test socket with maintained transverse airflow greater than 500 lfpm. The device will meet specifications after thermal equilibrium has been reached under these conditions.

NOTE: All specifications are taken at 125MHz and 156.25MHz.

NOTE 1: Please refer to the Phase Noise Plot.

NOTE 2: Defined as skew between outputs at the same supply voltage and with equal load conditions.

Measured at the output differential cross points.

NOTE 3: This parameter is defined in accordance with JEDEC Standard 65.

[查询"841664AGILF"供应商](#)

TYPICAL PHASE NOISE AT 125MHz At 3.3V

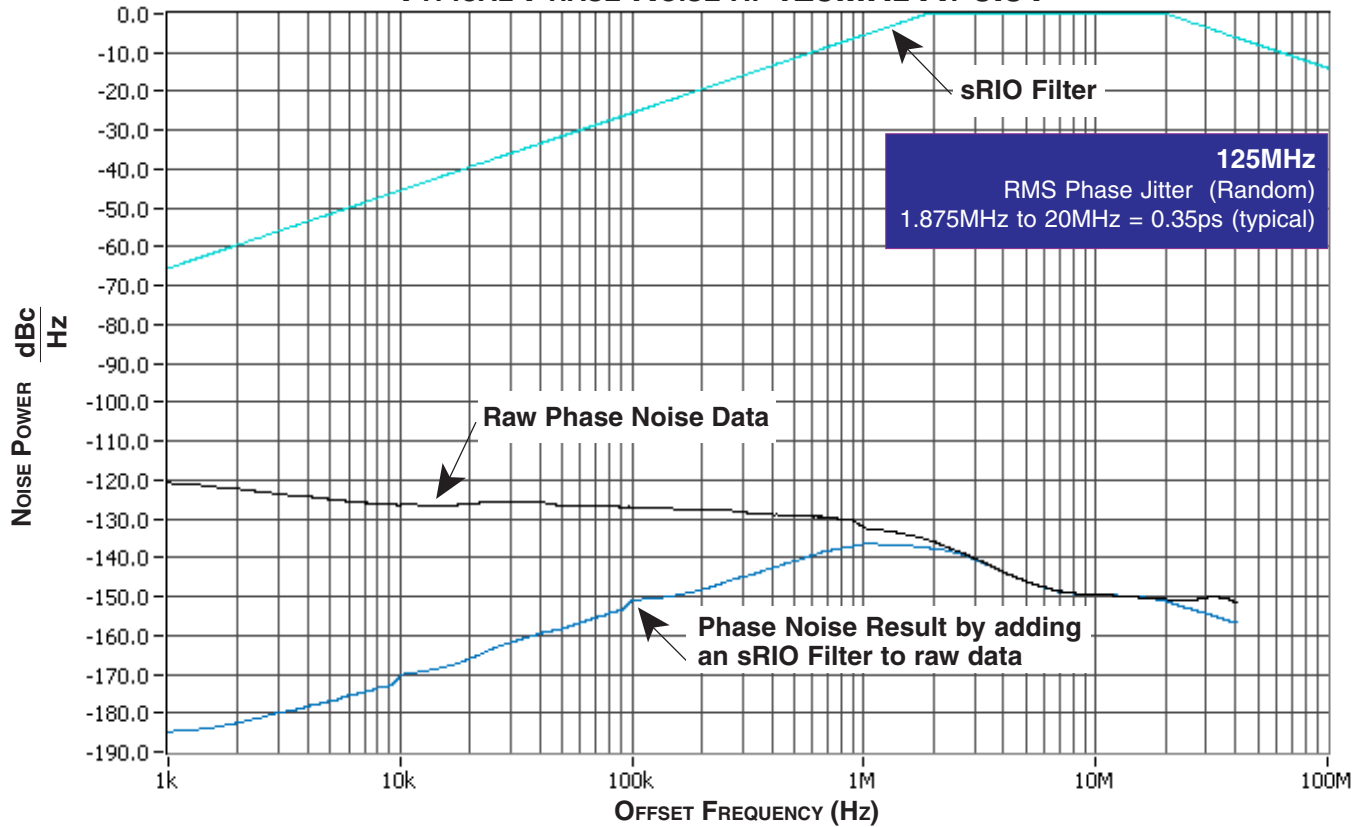

TYPICAL PHASE NOISE AT 156.25MHz At 3.3V

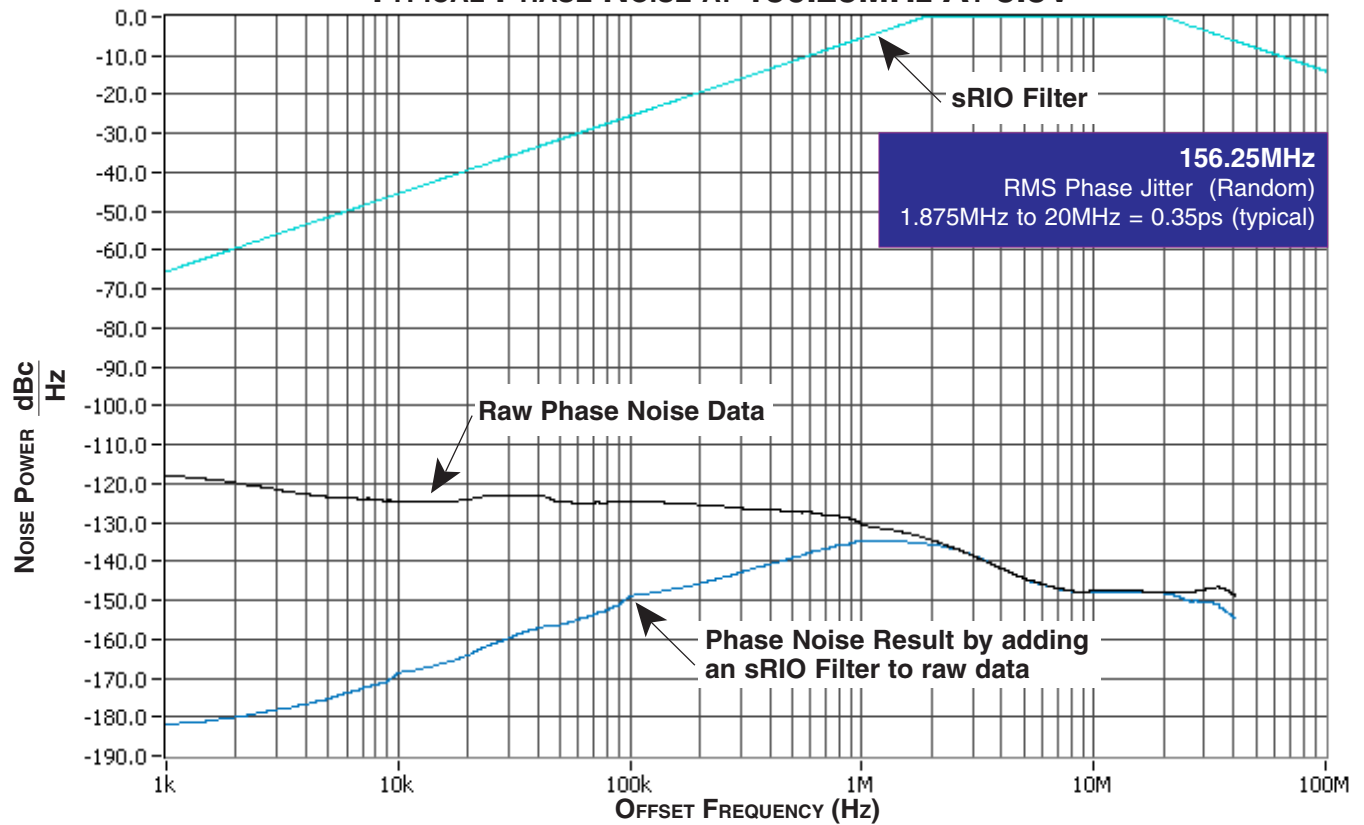

[查询"841664AGILF"供应商](#)

PARAMETER MEASUREMENT INFORMATION

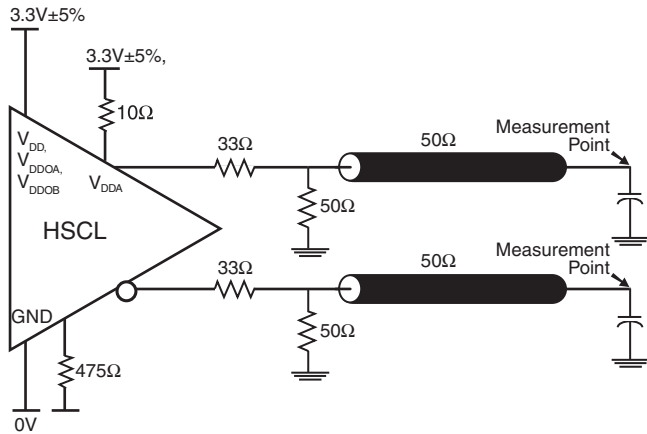

3.3V HCSL OUTPUT LOAD AC TEST CIRCUIT

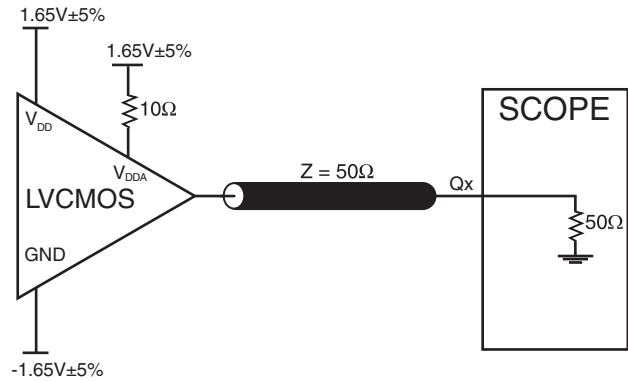

3.3V LVCMOS OUTPUT LOAD AC TEST CIRCUIT

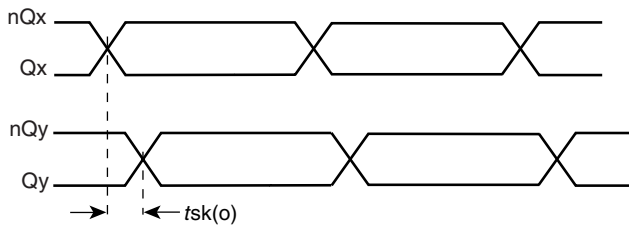

HCSL OUTPUT SKEW

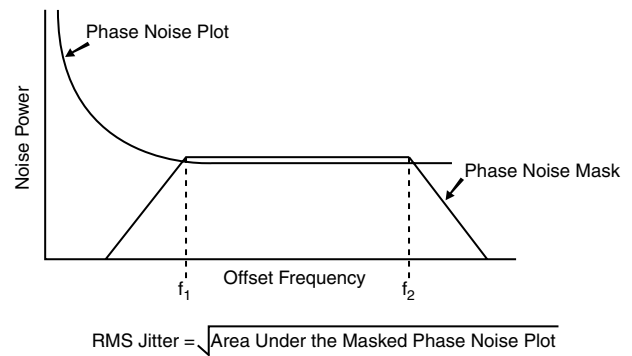

RMS PHASE JITTER

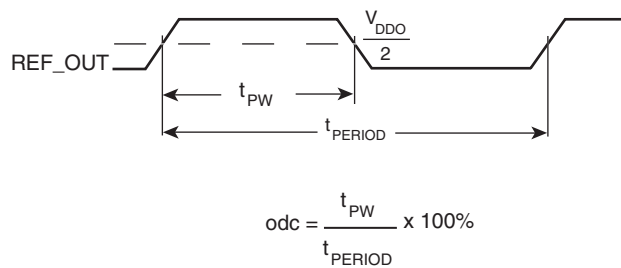

LVCMOS OUTPUT DUTY CYCLE/PULSE WIDTH/PERIOD

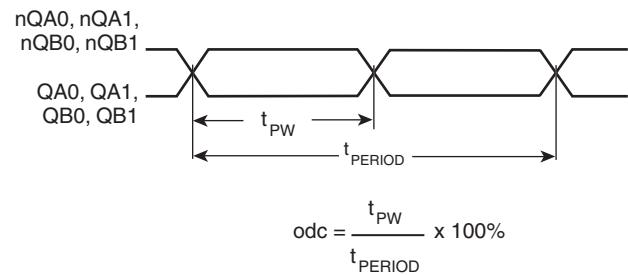

HCSL OUTPUT DUTY CYCLE/PULSE WIDTH/PERIOD

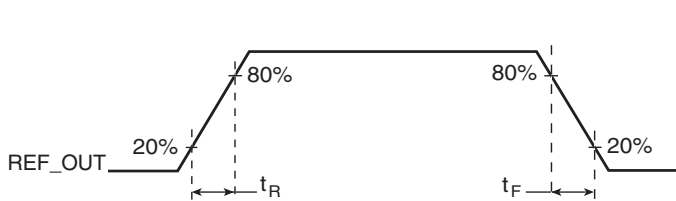

LVCMOS OUTPUT RISE/FALL TIME

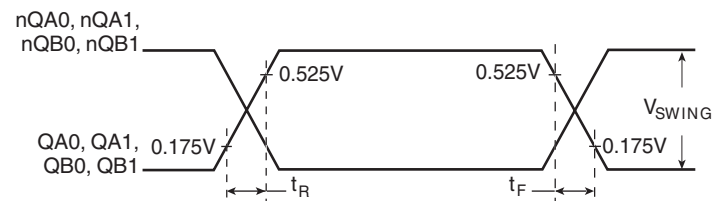

HCSL OUTPUT RISE/FALL TIME

[查询"841664AGILF"供应商](#)

APPLICATION INFORMATION

POWER SUPPLY FILTERING TECHNIQUES

As in any high speed analog circuitry, the power supply pins are vulnerable to random noise. To achieve optimum jitter performance, power supply isolation is required. The ICS841664I provides separate power supplies to isolate any high switching noise from the outputs to the internal PLL. V_{DD} , V_{DDA} , V_{DDOA} and V_{DDOB} should be individually connected to the power supply plane through vias, and $0.01\mu\text{F}$ bypass capacitors should be used for each pin. *Figure 1* illustrates this for a generic V_{DD} pin and also shows that V_{DDA} requires that an additional 10Ω resistor along with a $10\mu\text{F}$ bypass capacitor be connected to the V_{DDA} pin.

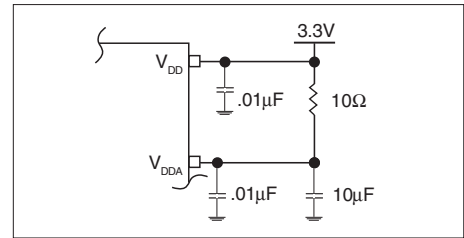

FIGURE 1. POWER SUPPLY FILTERING

CRYSTAL INPUT INTERFACE

The ICS841664I has been characterized with 18pF parallel resonant crystals. The capacitor values shown in *Figure 2* below

were determined using a 25MHz , 18pF parallel resonant crystal and were chosen to minimize the ppm error.

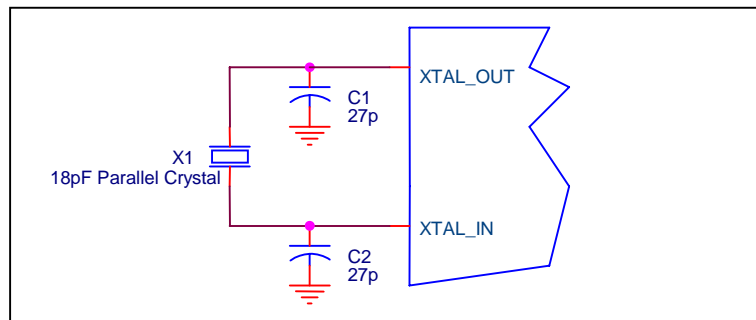

FIGURE 2. CRYSTAL INPUT INTERFACE

[查询"841664AGILF"供应商](#)

LVC MOS TO XTAL INTERFACE

The XTAL_IN input can accept a single-ended LVC MOS signal through an AC couple capacitor. A general interface diagram is shown in *Figure 3*. The XTAL_OUT pin can be left floating. The input edge rate can be as slow as 10ns. For LVC MOS inputs, it is recommended that the amplitude be reduced from full swing to half swing in order to prevent signal interference with the power rail and to reduce noise. This configuration requires that the output impedance of the driver (R_o) plus the

series resistance (R_s) equals the transmission line impedance. In addition, matched termination at the crystal input will attenuate the signal in half. This can be done in one of two ways. First, R_1 and R_2 in parallel should equal the transmission line impedance. For most 50Ω applications, R_1 and R_2 can be 100Ω. This can also be accomplished by removing R_1 and making R_2 50Ω.

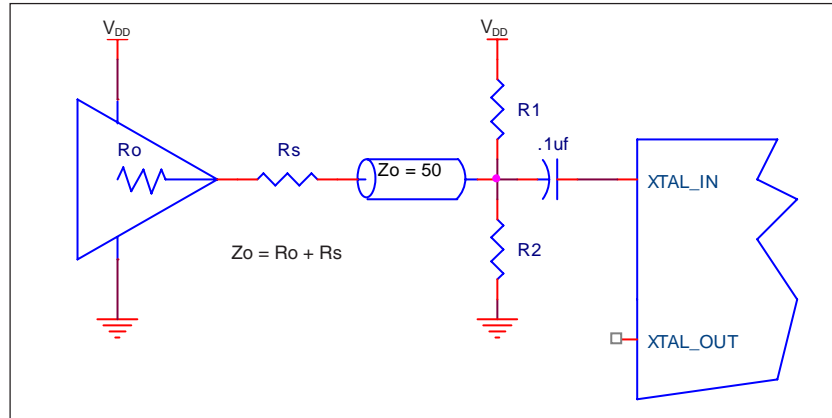

FIGURE 3. GENERAL DIAGRAM FOR LVC MOS DRIVER TO XTAL INPUT INTERFACE

RECOMMENDATIONS FOR UNUSED INPUT AND OUTPUT PINS

INPUTS:

CRYSTAL INPUTS

For applications not requiring the use of the crystal oscillator input, both XTAL_IN and XTAL_OUT can be left floating. Though not required, but for additional protection, a 1kΩ resistor can be tied from XTAL_IN to ground.

REF_IN INPUT

For applications not requiring the use of the reference clock, it can be left floating. Though not required, but for additional protection, a 1kΩ resistor can be tied from the REF_IN to ground.

LVC MOS CONTROL PINS

All control pins have internal pull-ups or pull-downs; additional resistance is not required but can be added for additional protection. A 1kΩ resistor can be used.

OUTPUTS:

HCSL OUTPUTS

All unused HCSL outputs can be left floating. We recommend that there is no trace attached. Both sides of the differential output pair should either be left floating or terminated.

LVC MOS OUTPUT

The unused LVC MOS output can be left floating. We recommend that there is no trace attached.

[查询"841664AGILF"供应商](#)

RECOMMENDED TERMINATION

Figure 4A is the recommended termination for applications which require the receiver and driver to be on a separate PCB. All traces should be 50Ω impedance.

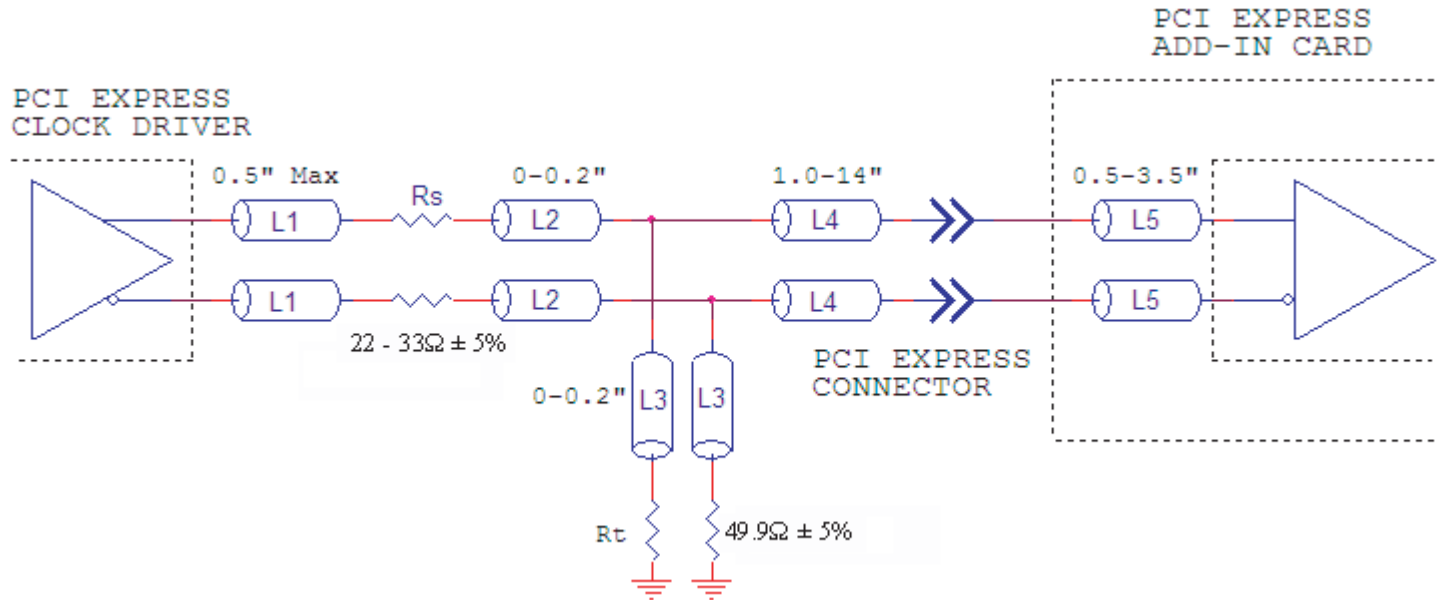

FIGURE 4A. RECOMMENDED TERMINATION

Figure 4B is the recommended termination for applications which require a point to point connection and contain the driver and receiver on the same PCB. All traces should all be 50Ω impedance.

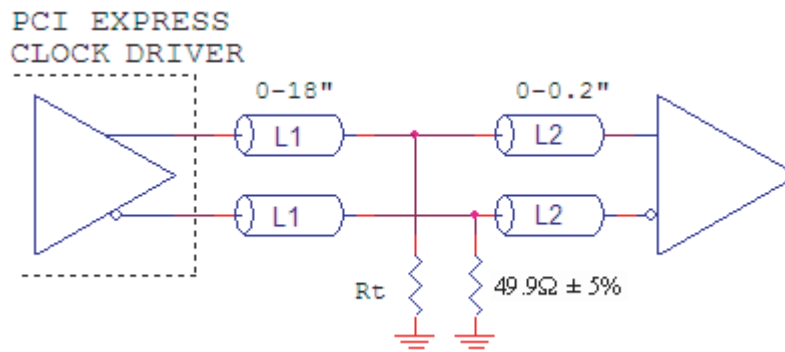

FIGURE 4B. RECOMMENDED TERMINATION

[查询"841664AGILF"供应商](#)

SCHEMATIC EXAMPLE

Figure 5 shows an example of ICS841664I application schematic. In this example, the device is operated at $V_{cc} = 3.3V$. The 18pF parallel resonant 25MHz crystal is used. The $C1 = 27pF$ and $C2 = 27pF$ are recommended for frequency accuracy. For different board layout, the $C1$ and $C2$ may be slightly adjusted for optimizing

frequency accuracy. One example of HCSL and one example of LVCMOS terminations are shown in this schematic. The decoupling capacitors should be located as close as possible to the power pin.

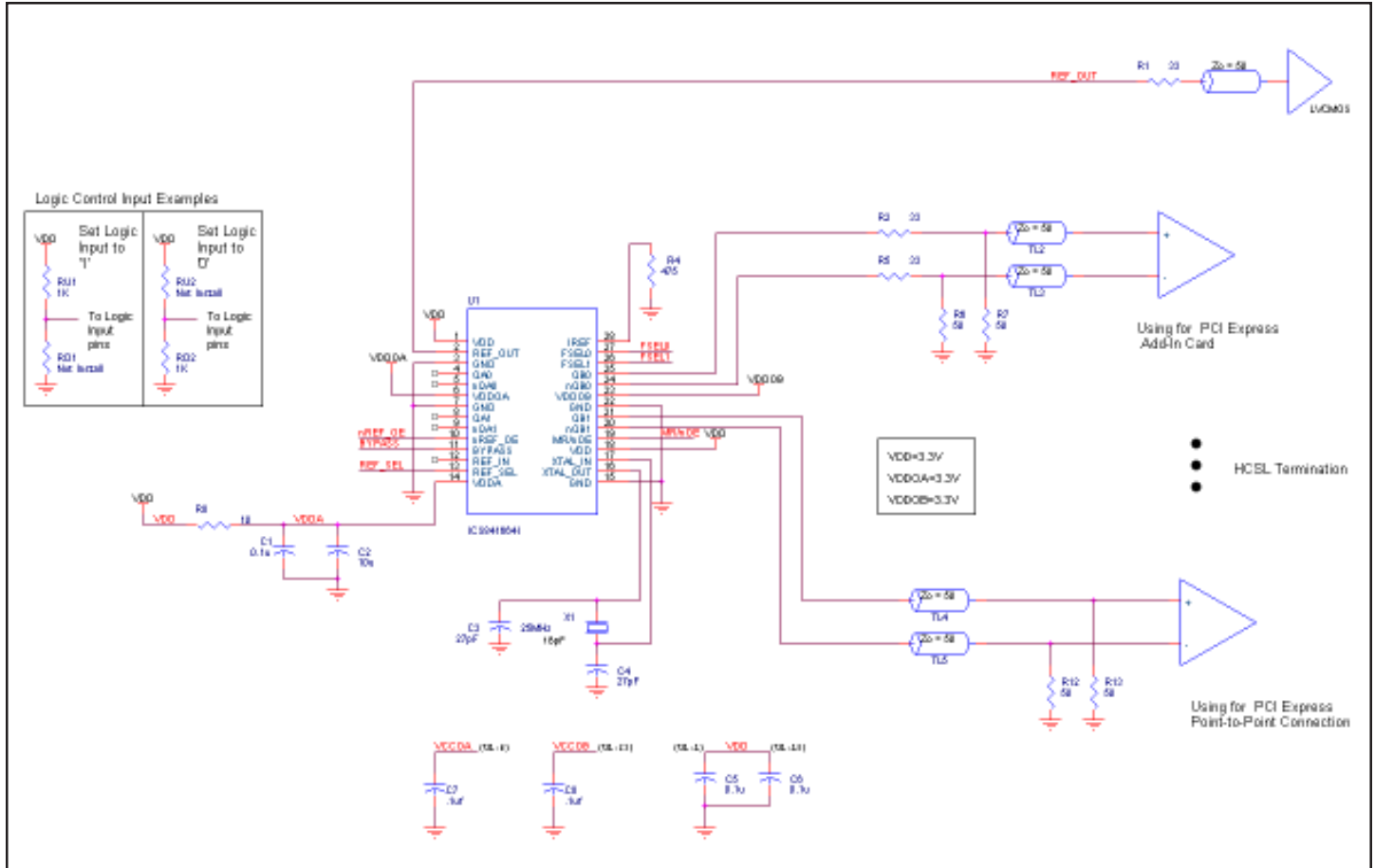

FIGURE 5. ICS841664I SCHEMATIC LAYOUT

[查询"841664AGILF"供应商](#)

POWER CONSIDERATIONS

This section provides information on power dissipation and junction temperature for the ICS841664I. Equations and example calculations are also provided.

1. Power Dissipation.

The total power dissipation for the ICS841664I is the sum of the core power plus the power dissipated in the load(s). The following is the power dissipation for $V_{DD} = 3.3V + 5\% = 3.465V$, which gives worst case results.

Core and HCSL Output Power Dissipation

- Power (core)_{MAX} = $V_{DD,MAX} * (I_{DD} + I_{DDA}) = 3.465V * (70mA + 15mA) = 294.5mW$
- Power (outputs)_{MAX} = **44.5mW/Loaded Output pair**
If all outputs are loaded, the total power is $4 * 44.5mW = 178mW$

LVC MOS Output Power Dissipation

- Dynamic Power Dissipation at 25MHz
Power (25MHz) = $C_{PD} * \text{Frequency} * (V_{DD})^2 = 18pF * 25MHz * (3.465V)^2 = 5.40mW \text{ per output}$

Total Power Dissipation

- **Total Power**
= Power (core) + Power (Outputs) + Total Power (25MHz)
= $294.5mW + 178mW + 5.4mW$
= **477.9mW**

2. Junction Temperature.

Junction temperature, T_j , is the temperature at the junction of the bond wire and bond pad and directly affects the reliability of the device. The maximum recommended junction temperature for HiPerClockS™ devices is 125°C.

The equation for T_j is as follows: $T_j = \theta_{JA} * Pd_total + T_A$

T_j = Junction Temperature

θ_{JA} = Junction-to-Ambient Thermal Resistance

Pd_total = Total Device Power Dissipation (example calculation is in Section 1 above)

T_A = Ambient Temperature

In order to calculate junction temperature, the appropriate junction-to-ambient thermal resistance θ_{JA} must be used. Assuming no air flow and a multi-layer board, the appropriate value is 64.5°C/W per Table 7 below.

Therefore, T_j for an ambient temperature of 85°C with all outputs switching is:

$$85^\circ\text{C} + 0.478\text{W} * 64.5^\circ\text{C/W} = 115.8^\circ\text{C}. \text{ This is below the limit of } 125^\circ\text{C}.$$

This calculation is only an example. T_j will obviously vary depending on the number of loaded outputs, supply voltage, air flow, and the type of board (multi-layer).

TABLE 7. THERMAL RESISTANCE θ_{JA} FOR 28-LEAD TSSOP, FORCED CONVECTION

θ_{JA} by Velocity (Meters per Second)			
	0	1	2.5
Multi-Layer PCB, JEDEC Standard Test Boards	64.5°C/W	60.4°C/W	58.5°C/W

[查询"841664AGILF"供应商](#)

3. Calculations and Equations.

The purpose of this section is to calculate power dissipation on the IC per HCSL output pair.

HCSL output driver circuit and termination are shown in Figure 6.

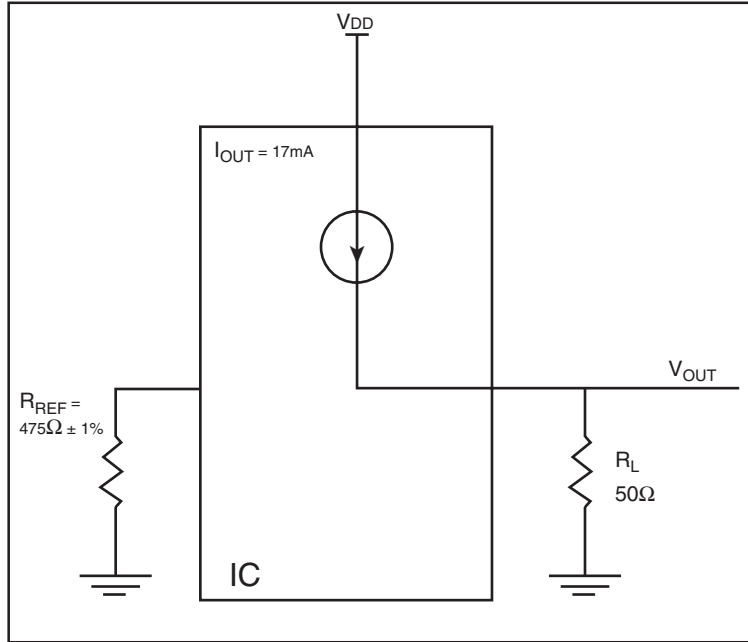

FIGURE 6. HCSL DRIVER CIRCUIT AND TERMINATION

HCSL is a current steering output which sources a maximum of 17mA of current per output. To calculate worst case on-chip power dissipation, use the following equations which assume a 50Ω load to ground.

The highest power dissipation occurs when V_{DD_MAX} .

$$\text{Power} = (V_{DD_MAX} - V_{OUT}) * I_{OUT}$$

$$\text{since } V_{OUT} = I_{OUT} * R_L$$

$$\text{Power} = (V_{DD_MAX} - I_{OUT} * R_L) * I_{OUT}$$

$$= (3.465V - 17mA * 50\Omega) * 17mA$$

Total Power Dissipation per output pair = **44.5mW**

[查询"841664AGILF"供应商](#)

RELIABILITY INFORMATION

TABLE 8. θ_{JA} vs. AIR FLOW TABLE FOR 28 LEAD TSSOP

θ_{JA} by Velocity (Meters per Second)			
Multi-Layer PCB, JEDEC Standard Test Boards	0	1	2.5
	64.5°C/W	60.4°C/W	58.5°C/W

TRANSISTOR COUNT

The transistor count for ICS841664I is: 2954

PACKAGE OUTLINE AND DIMENSIONS

PACKAGE OUTLINE - G SUFFIX FOR 28 LEAD TSSOP

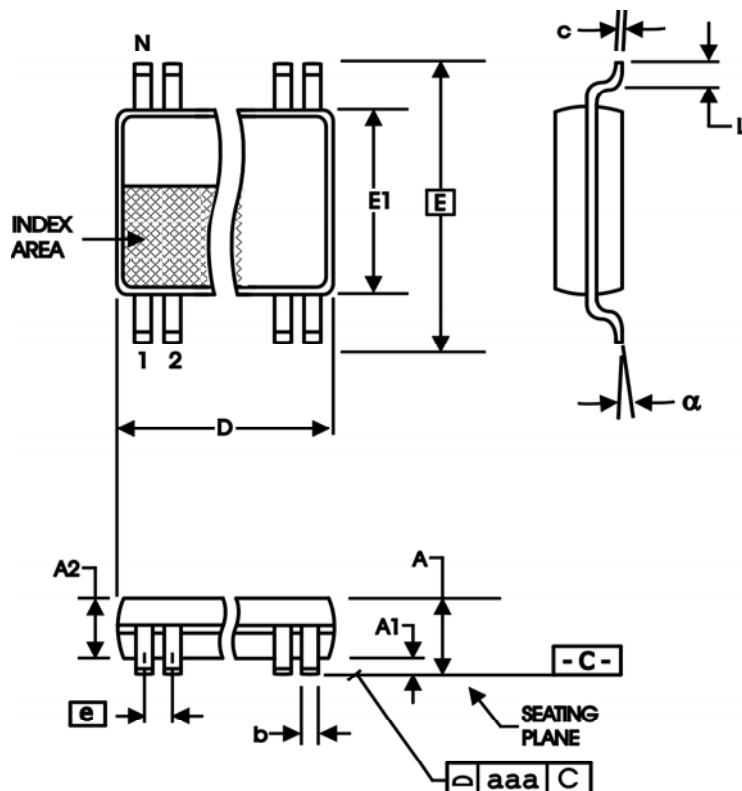

TABLE 9. PACKAGE DIMENSIONS

SYMBOL	Millimeters	
	Minimum	Maximum
N	28	
A	--	1.20
A1	0.05	0.15
A2	0.80	1.05
b	0.19	0.30
c	0.09	0.20
D	9.60	9.80
E	8.10 BASIC	
E1	6.00	6.20
e	0.65 BASIC	
L	0.45	0.75
α	0°	8°
aaa	--	0.10

Reference Document: JEDEC Publication 95, MO-153

[查询"841664AGILF"供应商](#)

TABLE 10. ORDERING INFORMATION

Part/Order Number	Marking	Package	Shipping Packaging	Temperature
841664AGI	ICS841664AGI	28 Lead TSSOP	tube	-40°C to 85°C
841664AGIT	ICS841664AGI	28 Lead TSSOP	1000 tape & reel	-40°C to 85°C
841664AGILF	ICS841664AGILF	28 Lead "Lead-Free" TSSOP	tube	-40°C to 85°C
841664AGILFT	ICS841664AGILF	28 Lead "Lead-Free" TSSOP	1000 tape & reel	-40°C to 85°C

NOTE: Parts that are ordered with an "LF" suffix to the part number are the Pb-Free configuration and are RoHS compliant.

While the information presented herein has been checked for both accuracy and reliability, Integrated Device Technology, Incorporated (IDT) assumes no responsibility for either its use or for infringement of any patents or other rights of third parties, which would result from its use. No other circuits, patents, or licenses are implied. This product is intended for use in normal commercial and industrial applications. Any other applications such as those requiring high reliability or other extraordinary environmental requirements are not recommended without additional processing by IDT. IDT reserves the right to change any circuitry or specifications without notice. ICS does not authorize or warrant any IDT product for use in life support devices or critical medical instruments.

[查询"841664AGILF"供应商](#)

Innovate with IDT and accelerate your future networks. Contact:

www.IDT.com

For Sales

800-345-7015 (inside USA)
+408-284-8200 (outside USA)
Fax: 408-284-2775
www.IDT.com/go/contactIDT

For Tech Support

netcom@idt.com
+480-763-2056

Corporate Headquarters

Integrated Device Technology, Inc.
6024 Silver Creek Valley Road
San Jose, CA 95138
United States
800-345-7015 (inside USA)
+408-284-8200 (outside USA)