

October 1999

54FCT138

1-of-8 Decoder/Demultiplexer

General Description

The FCT138 is a high-speed 1-of-8 decoder/demultiplexer. This device is ideally suited for high-speed bipolar memory chip select address decoding. The multiple input enables allow parallel expansion to a 1-of-24 decoder using just three FCT138 devices or a 1-of-32 decoder using four FCT138 devices and one inverter.

Features

- Demultiplexing capability
- Multiple input enable for easy expansion
- Active LOW mutually exclusive outputs
- Outputs sink capability of 32mA, source capability of 12mA
- TTL input and output level compatible
- CMOS power consumption
- Standard Microcircuit Drawing (SMD) 5962-8765401

Ordering Code

Military	Package Number	Package Description
54FCT138DMQB	J16A	16-Lead Ceramic Dual-In-Line
54FCT138FMQB	W16A	16-Lead Cerpack
54FCT138LMQB	E20A	20-Lead Ceramic Leadless Chip Carrier, Type C

Logic Symbols

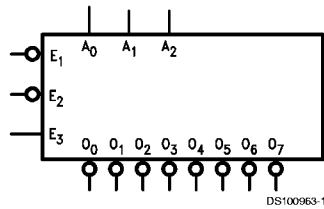

DS100963-1

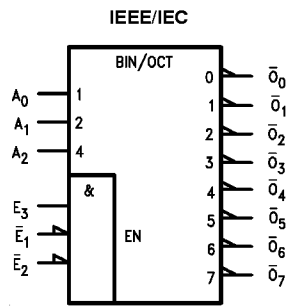

DS100963-7

Pin Names	Description
A ₀ -A ₂	Address Inputs
\bar{E}_1 - \bar{E}_2	Enable Inputs
E ₃	Enable Input
\bar{O}_0 - \bar{O}_7	Outputs

Connection Diagrams

Pin Assignment for DIP and Flatpak

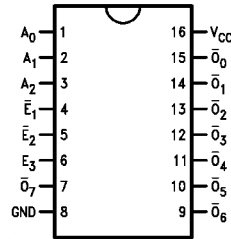

DS100963-2

Pin Assignment for LCC

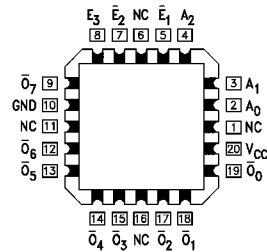

DS100963-3

FACT® is a registered trademark of Fairchild Semiconductor Corporation.

54FCT138

Functional Description

The FCT138 high-speed 1-of-8 decoder/demultiplexer accepts three binary weighted inputs (A_0, A_1, A_2) and, when enabled, provides eight mutually exclusive active-LOW outputs ($\bar{O}_0-\bar{O}_7$). The FCT138 features three Enable inputs, two active-LOW (\bar{E}_1, \bar{E}_2) and one active-HIGH (E_3). All outputs will be HIGH unless \bar{E}_1 and \bar{E}_2 are LOW and E_3 is HIGH. This multiple enable function allows easy parallel ex-

pansion of the device to a 1-of-32 (5 lines to 32 lines) decoder with just four FCT138 devices and one inverter (see *Figure 1*). The FCT138 can be used as an 8-output demultiplexer by using one of the active LOW Enable inputs as the data input and the other Enable inputs as strobes. The Enable inputs which are not used must be permanently tied to their appropriate active-HIGH or active-LOW state.

Inputs						Outputs							
\bar{E}_1	\bar{E}_2	E_3	A_0	A_1	A_2	\bar{O}_0	\bar{O}_1	\bar{O}_2	\bar{O}_3	\bar{O}_4	\bar{O}_5	\bar{O}_6	\bar{O}_7
H	X	X	X	X	X	H	H	H	H	H	H	H	H
X	H	X	X	X	X	H	H	H	H	H	H	H	H
X	X	L	X	X	X	H	H	H	H	H	H	H	H
L	L	H	L	L	L	L	H	H	H	H	H	H	H
L	L	H	H	L	L	H	L	H	H	H	H	H	H
L	L	H	L	H	L	H	H	L	H	H	H	H	H
L	L	H	H	H	L	H	H	H	L	H	H	H	H
L	L	H	L	L	H	H	H	H	H	L	H	H	H
L	L	H	H	L	H	H	H	H	H	H	L	H	H
L	L	H	L	H	H	H	H	H	H	H	H	L	H
L	L	H	H	H	H	H	H	H	H	H	H	H	L

H = HIGH Voltage Level
L = LOW Voltage Level
X = Immaterial

Logic Diagram

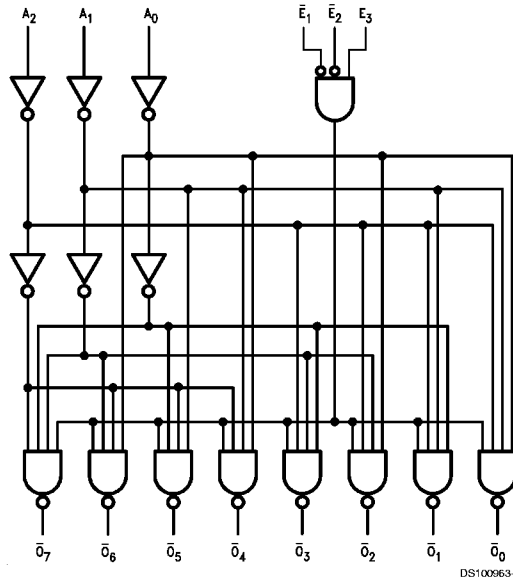

DS100963-4

Please note that this diagram is provided only for the understanding of logic operations and should not be used to estimate propagation delays.

Logic Diagram (Continued)

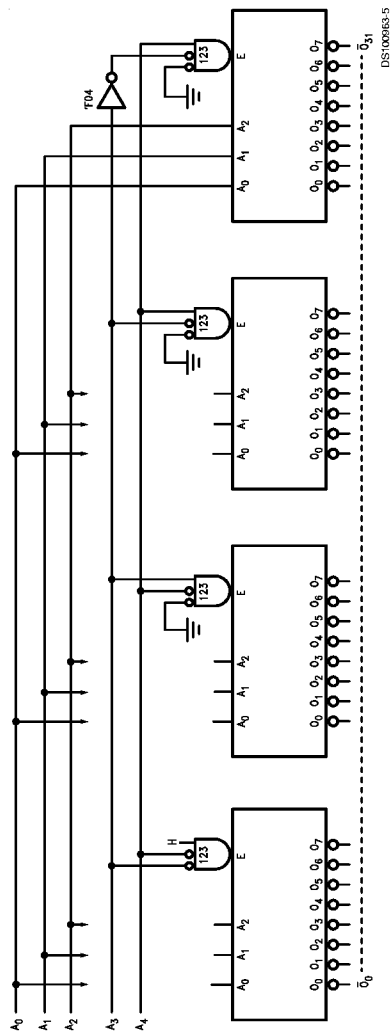

FIGURE 1. Expansion to 1-of-32 Decoding

54FCT138

Absolute Maximum Ratings (Note 1)

If Military/Aerospace specified devices are required, please contact the National Semiconductor Sales Office/Distributors for availability and specifications.

Storage Temperature	-65°C to +150°C
Ambient Temperature under Bias	-55°C to +125°C
Junction Temperature under Bias	
Ceramic	-55°C to +175°C
V _{CC} Pin Potential to Ground Pin	-0.5V to +7.0V
Input Voltage (Note 1)	-0.5V to +7.0V
Input Current (Note 1)	-30 mA to +5.0 mA
Voltage Applied to Any Output in the Disabled or Power-Off State in the HIGH State	-0.5V to +5.5V -0.5V to V _{CC}
Current Applied to Output	

in LOW State (Max) Twice the rated I_{OL} (mA)
DC Latchup Source Current -500 mA

Recommended Operating Conditions

Free Air Ambient Temperature	
Military	-55°C to +125°C
Supply Voltage	
Military	+4.5V to +5.5V
Minimum Input Edge Rate	(ΔV/Δt)
Data Input	50 mV/ns
Enable Input	20 mV/ns

Note 1: Absolute maximum ratings are those values beyond which damage to the device may occur. The databook specifications should be met, without exception, to ensure that the system design is reliable over its power supply, temperature, and output/input loading variables. National does not recommend operation of FACT® circuits outside databook specifications.

DC Characteristics for 'FCT Family Devices

Symbol	Parameter	FCT138		Units	V _{CC}	Conditions
		Min	Max			
V _{IH}	Input HIGH Voltage	2.0		V		Recognized HIGH Signal
V _{IL}	Input LOW Voltage		0.8	V		Recognized LOW Signal
V _{CD}	Input Clamp Diode Voltage		-1.2	V	Min	I _{IN} = -18 mA
V _{OH}	Output HIGH Voltage	54FCT	4.3	V	Min	I _{OH} = -300 μA
		54FCT	2.4			I _{OH} = -12 mA
V _{OL}	Output LOW Voltage	54FCT	0.2	V	Min	I _{OL} = 300 μA
		54FCT	0.5			I _{OL} = 32 mA
I _{IH}	Input HIGH Current		5	μA	Max	V _{IN} = V _{CC}
I _{IL}	Input LOW Current		-5	μA	Max	V _{IN} = 0.0V
I _{OS}	Output Short-Circuit Current		-60	mA	Max	V _{OUT} = 0.0V
I _{CCQ}	Quiescent Power Supply Current		1.5	mA	Max	V _{IN} < 0.2V or V _{IN} 5.3V, V _{CC} = 5.5V
ΔI _{CC}	Quiescent Power Supply Current		2.0	mA	Max	V _I = 3.4V, V _{CC} = 5.5V
I _{CCD}	Dynamic I _{CC}		0.4	mA/MHz	Max	Outputs Open, V _{CC} = 5.5V, V _{IN} 5.3V or V _{IN} < 0.2V, One Bit Toggling, 50% Duty Cycle, \overline{OE} = GND, LE = V _{CC}
I _{CCT}	Total Power Supply Current		5.5	mA	Max	Outputs Open, f _{CP} = 10 MHz, V _{CC} = 5.5V, V _{IN} 5.3V or V _{IN} < 0.2V, One Bit Toggling, 50% Duty Cycle, \overline{OE} = GND, LE = V _{CC}

Note 2: All outputs loaded; thresholds on input associated with output under test.

Note 3: Maximum test duration 2.0 ms, one output loaded at a time.

AC Electrical Characteristics

Symbol	Parameter	V _{CC} (V) (Note 4)	54FCT		Units	Fig. No.
			T _A = -55°C to +125°C C _L = 50 pF			
			Min	Max		
t _{PLH}	Propagation Delay A _n to \bar{O}_n	5.0	1.0	12.0	ns	
t _{PHL}	Propagation Delay A _n to \bar{O}_n	5.0	1.0	12.0	ns	
t _{PLH}	Propagation Delay \bar{E}_1 or \bar{E}_2 to \bar{O}_n	5.0	1.0	12.5	ns	
t _{PHL}	Propagation Delay \bar{E}_1 or \bar{E}_2 to \bar{O}_n	5.0	1.0	12.5	ns	
t _{PLH}	Propagation Delay E ₃ to \bar{O}_n	5.0	1.0	12.5	ns	
t _{PHL}	Propagation Delay E ₃ to \bar{O}_n	5.0	1.0	12.5	ns	

Note 4: Voltage Range 5.0 is 5.0V ±0.5V

Capacitance

Symbol	Parameter	Typ	Units	Conditions
C _{IN}	Input Capacitance	4.5	pF	V _{CC} = OPEN
C _{PD}	Power Dissipation Capacitance	60.0	pF	V _{CC} = 5.0V

54FCT138

Physical Dimensions inches (millimeters) unless otherwise noted

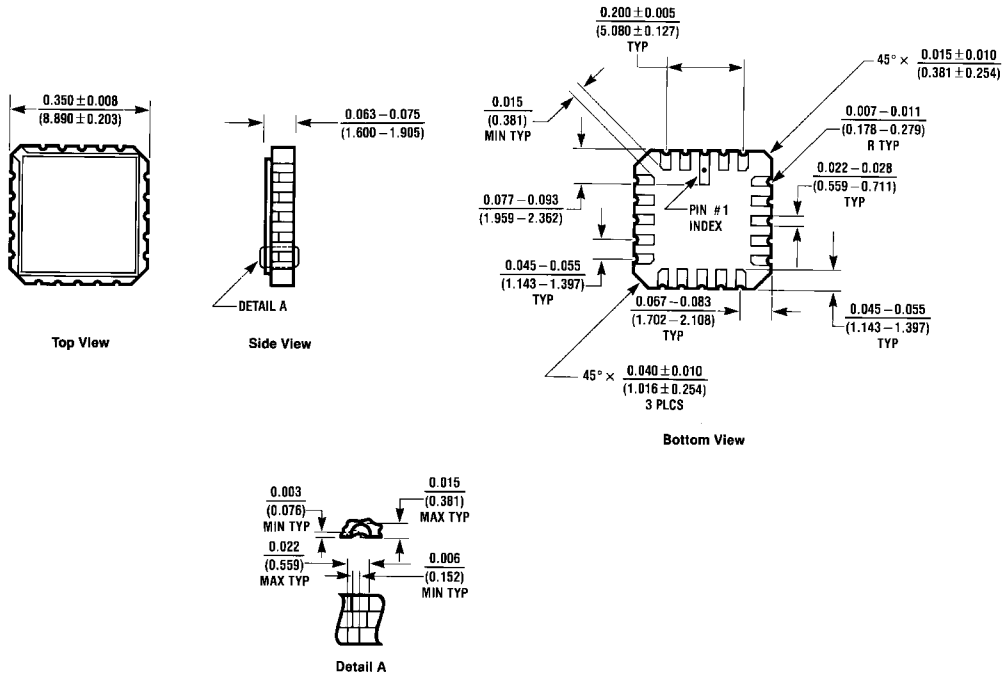

E20A (REV D)

20 Terminal Ceramic Leadless Chip Carrier (L)
 NS Package Number E20A

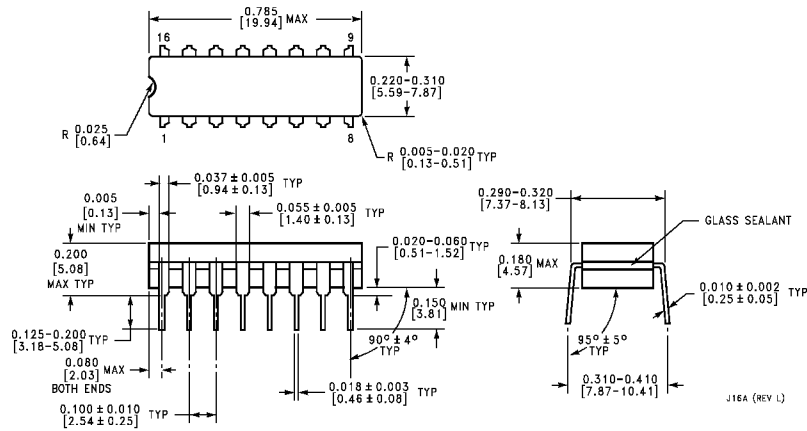

J16A (REV L)

16 Lead Ceramic Dual-In-Line Package (D)
 NS Package Number J16A

Physical Dimensions inches (millimeters) unless otherwise noted (Continued)

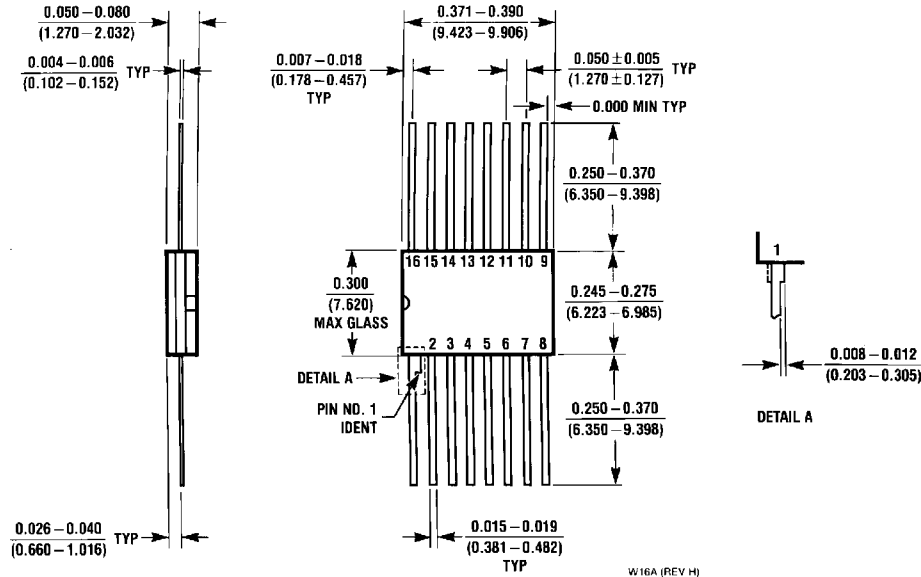

**16 Lead Ceramic Flatpak (F)
NS Package Number W16A**

LIFE SUPPORT POLICY

NATIONAL'S PRODUCTS ARE NOT AUTHORIZED FOR USE AS CRITICAL COMPONENTS IN LIFE SUPPORT DEVICES OR SYSTEMS WITHOUT THE EXPRESS WRITTEN APPROVAL OF THE PRESIDENT AND GENERAL COUNSEL OF NATIONAL SEMICONDUCTOR CORPORATION. As used herein:

1. Life support devices or systems are devices or systems which, (a) are intended for surgical implant into the body, or (b) support or sustain life, and whose failure to perform when properly used in accordance with instructions for use provided in the labeling, can be reasonably expected to result in a significant injury to the user.
2. A critical component is any component of a life support device or system whose failure to perform can be reasonably expected to cause the failure of the life support device or system, or to affect its safety or effectiveness.

National Semiconductor Corporation
Americas
Tel: 1-800-272-9959
Fax: 1-800-737-7018
Email: support@nsc.com

www.national.com

National Semiconductor Europe
Fax: +49 (0) 1 80-530 85 86
Email: europe.support@nsc.com
Deutsch Tel: +49 (0) 1 80-530 85 85
English Tel: +49 (0) 1 80-532 78 32
Français Tel: +49 (0) 1 80-532 93 58
Italiano Tel: +49 (0) 1 80-534 16 80

National Semiconductor Asia Pacific Customer Response Group
Tel: 65-2544466
Fax: 65-2504466
Email: sea.support@nsc.com

National Semiconductor Japan Ltd.
Tel: 81-3-5639-7560
Fax: 81-3-5639-7507