

# DH124C

Inductance Range: 3.3~100μH

## DIMENSIONS / 外形寸法圖

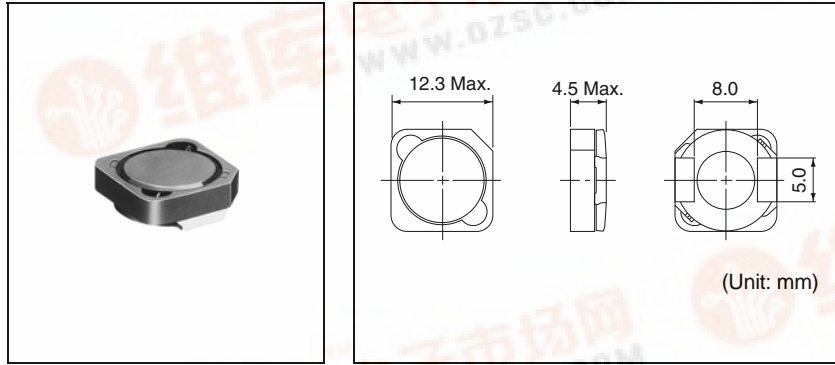

## Recommended patterns 推奨パターン圖

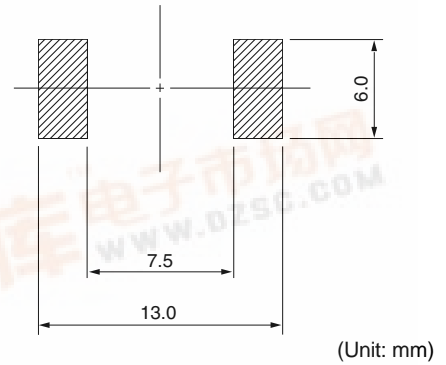

## FEATURES / 特長

- High reliability for vehicle application.
- Operating temperature range : -55°C~+125°C
- Low profile (12.3mm Max. square, 4.5mm Max. height).
- Magnetically shielded construction and low DC resistance.
- Suitable for large currents.
- Ideal for a variety of DC-DC converter inductor applications.
- RoHS compliant.
- 車載機器向け信頼性向上品
- 使用温度範囲：-55°C~+125°C
- 薄形構造(12.3mm角Max. 高さ4.5mm Max.)
- 閉磁路構造、低直流抵抗
- 大電流対応
- 各種機器のDC-DCコンバータ用インダクタに最適
- RoHS指令対応

## SELECTION GUIDE FOR STANDARD COILS

### TYPE DH124C (With Ferrite Shield) 閉磁路タイプ(リングコア有り) (Quantity/reel; 500 PCS)

東光品番	インダクタンス <sup>(1)</sup>	許容差	直流抵抗 <sup>(2)</sup>	直流重畳許容電流 <sup>(3)</sup>	温度上昇許容電流 <sup>(3)</sup>
TOKO Part Number	Inductance <sup>(1)</sup> L (μH)	Tolerance (%)	DC Resistance <sup>(2)</sup> (mΩ) Max.	Inductance Decrease Current <sup>(3)</sup> (A) Max. $\frac{\Delta L}{L} = 30\%$	Temperature Rise Current <sup>(3)</sup> $\Delta T = 20^\circ\text{C}$ (A) Max.
1010ASW-3R3M	3.3	± 20	12	6.30	4.80
1010ASW-4R7M	4.7	± 20	15	5.30	4.40
1010ASW-6R2M	6.2	± 20	17	4.70	4.10
1010ASW-8R2M	8.2	± 20	20	4.20	3.80
1010ASW-100M	10.0	± 20	22	3.70	3.60
1010ASW-150M	15.0	± 20	34	3.10	2.80
1010ASW-180M	18.0	± 20	38	2.90	2.70
1010ASW-220M	22.0	± 20	45	2.40	2.50
1010ASW-330M	33.0	± 20	56	2.10	2.20
1010ASW-470M	47.0	± 20	92	1.80	1.70
1010AYW-680M	68.0	± 20	195	1.60	1.20
1010AYW-820M	82.0	± 20	205	1.40	1.10
1010AYW-101M	100.0	± 20	230	1.20	1.00

(1) Inductance is measured with a LCR meter 4284A (Agilent Technologies) or equivalent.  
Test frequency at 100kHz

(2) DC Resistance is measured with a Digital Multimeter TR6871 (Advantest) or equivalent.

(3) Maximum allowable DC current is that which inductance decrease current, or temperature rise current, whichever is smaller.

• Inductance decrease current : The inductance value decreases 30% by the excitation of DC current. (reference ambient temperature 125°C)

• Temperature rise current : The temperature rises 20°C by excitation of DC current. (reference ambient temperature 20°C)

(1) インダクタンスはLCRメータ4284A(Agilent Technologies)または同等品により測定する。  
測定周波数は100kHzです。

(2) 直流抵抗はデジタルマルチメータTR6871(Advantest)または同等品により測定する。

(3) 最大許容電流：直流重畳許容電流値と温度上昇許容電流値の何れか小さい値です。

• 直流重畳許容電流：直流重畳特性においてインダクタンス値が30%低下した時の電流値。(周囲温度125°C)

• 温度上昇許容電流：直流を流した時の巻線温度上昇が20°Cに達する電流値。(周囲温度20°C)