

NPN SILICON HI FREQUENCY TRANSISTOR

DESCRIPTION:

The **ASI NE56787** is Designed for general purpose and ultra linear small signal amplifier applications up to 4.0 GHz.

FEATURES INCLUDE:

- Ideal for linear Class-A amplifiers

MAXIMUM RATINGS:

I_C	60 mA
V_{CBO}	25 V
V_{CEO}	12 V
V_{EBO}	2.0 V
P_{DISS}	600 mW @ $T_A \leq 75^\circ\text{C}$
T_J	-65°C to $+200^\circ\text{C}$
T_{STG}	-65°C to $+200^\circ\text{C}$
θ_{JC}	40 $^\circ\text{C/W}$

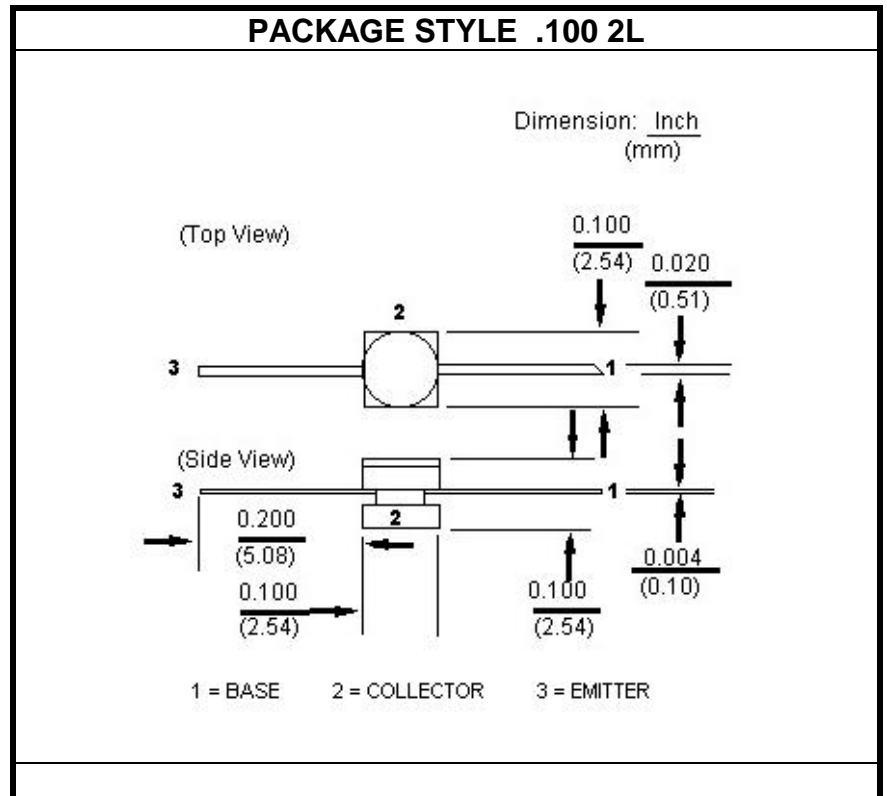

CHARACTERISTICS $T_C = 25^\circ\text{C}$

SYMBOL	TEST CONDITIONS	MINIMUM	TYPICAL	MAXIMUM	UNITS
I_{CBO}	$V_{CB} = 10\text{ V}$			1.0	μA
I_{EBO}	$V_{EB} = 1.0\text{ V}$			1.0	μA
h_{FE}	$V_{CE} = 10\text{ V}$ $I_C = 30\text{ mA}$	30	100	200	---
C_{OB}	$V_{CB} = 10\text{ V}$ $f = 1.0\text{ MHz}$		0.44	0.80	pF
f_s	$ S_{21} ^2 = 0\text{ dB}$	7.5	8.0		GHz