

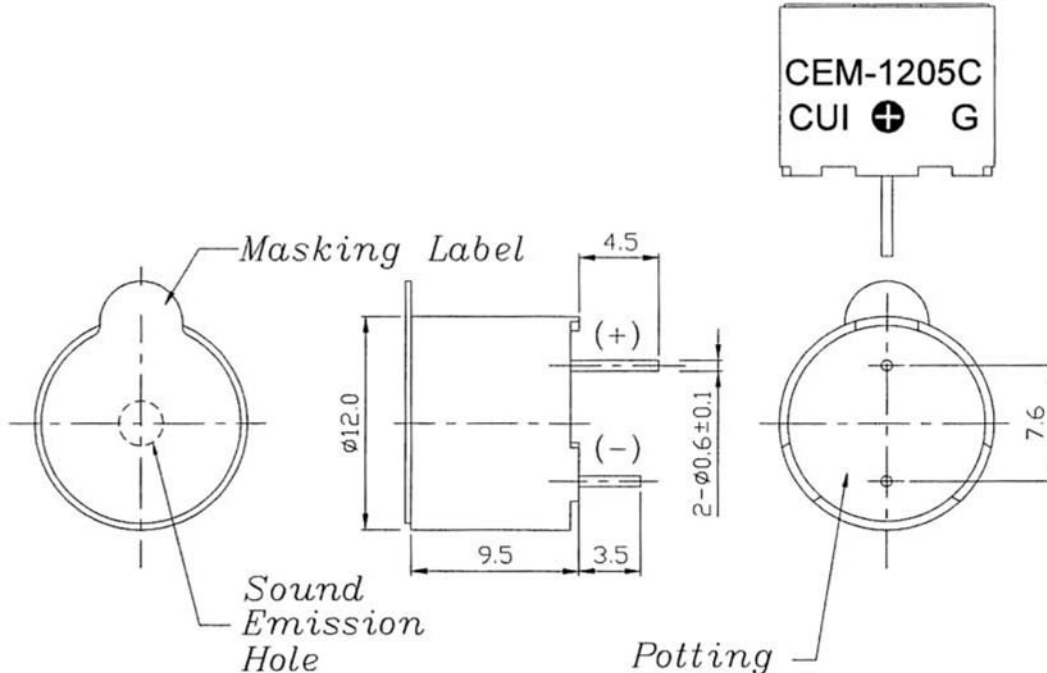

**Specifications**

Rated voltage	5.0 V dc
Operating voltage	4.0 ~ 7.0 V dc
Current consumption	35 mA max.
Sound pressure level	83 db min. at 10 cm (A-weight free air)/ 5 V dc
Resonant frequency	2300 Hz $\pm$ 300
Tone	Continuous
Operating temperature	-30 ~ +70° C
Storage temperature	-30 ~ +70° C
Dimensions	$\phi$ 12 x H9.5 mm
Weight	1.6 g
Material	PPO (Black)
Terminal	Pin type (Au Plating)
RoHS	yes

**Appearance Drawing**

 Tolerance:  $\pm$ 0.5

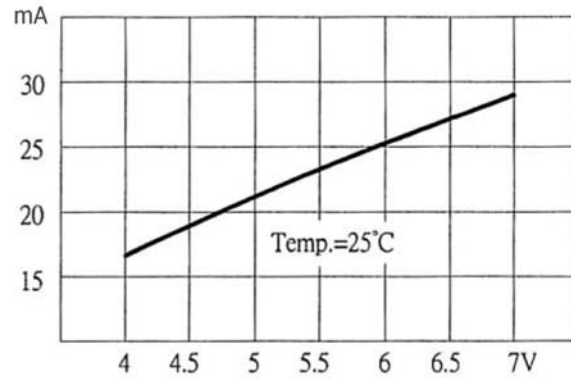
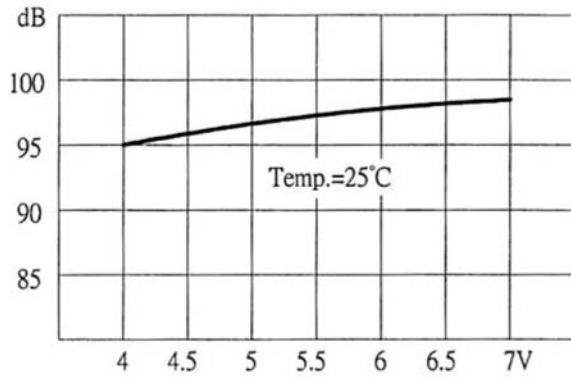
Voltage: Sound Pressure Level / Voltage: Current Consumption



Measurement Method

+V DC

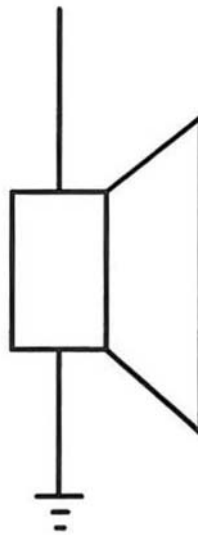

### Mechanical Characteristics

Item	Test Condition	Evaluation Standard
Solderability	Lead terminals are immersed in rosin for 5 seconds and then immersed in solder bath of $270 \pm 5^\circ\text{C}$ for $3 \pm 1$ seconds.	90% min. of the lead terminals will be wet with solder. (Except the edge of the terminal)
Soldering Heat Resistance	Lead terminals are immersed up to 1.5mm from buzzer's body in solder bath of $260 \pm 5^\circ\text{C}$ for $3 \pm 1$ seconds.	No interference in operation.
Terminal Mechanical Strength	For 10 seconds, the force of 9.8N (1.0kg) is applied to each terminal in axial direction.	No damage or cutting off.
Vibration	The buzzer should be measured after applying a vibration amplitude of 1.5 mm with 10 to 55 Hz band of vibration frequency to each of the 3 perpendicular directions for 2 hours.	After the test, the part should meet specification without any damage in appearance. The SPL should be within $\pm 10$ dBA compared with the initial measurement.
Drop Test	The part should be dropped from a height of 75 cm onto a 40 mm thick wooden board 3 times in 3 axes (X, Y, Z) for a total of 9 drops.	

### Environment Test

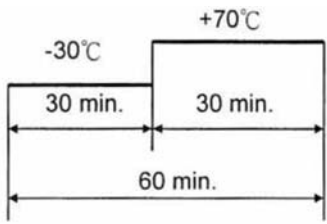
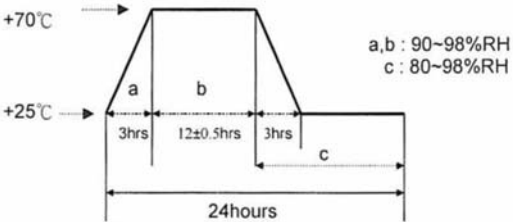
Item	Test Condition	Evaluation Standard
High temp. test	After being placed in a chamber at $+70^\circ\text{C}$ for 96 hours.	After the test, the part should meet specification without any damage in appearance and performance, except for the SPL. After being placed at $+25^\circ\text{C}$ for 4 hours. The SPL should be within $\pm 10$ dBA when compared with the initial measurement.
Low temp. test	After being placed in a chamber at $-30^\circ\text{C}$ for 96 hours.	
Thermal Shock	The part shall be subjected to 10 cycles. One cycle will consist of: <div style="text-align: center;">  </div>	
Temp./Humidity cycle test	The part shall be subjected to 10 cycles. One cycle will be 24 hours and consist of: <div style="text-align: center;">  </div>	

## Reliability Tests

Item	Test Condition	Evaluation Standard
Operating (Life Test)	1. Continuous life test: The part will be subjected to 72 at +45°C with 5 V dc applied.  2. Intermittent life test: A duty cycle of 1 minute on, 1 minute off, a minimum of 10,000 times at room temp (+25 ±2°C) with 5 V dc applied.	After the test, the part should meet specification without any damage in appearance and performance, except for the SPL. After being placed at +25°C for 4 hours. The SPL should be within ±10 dBA when compared with the initial measurement.

## Test Conditions

Standard Test Condition	a) Temperature: +5 ~ +35°C	b) Humidity: 45 - 85%	c) Pressure: 860-1060 mbar
Judgement Test Condition	a) Temperature: +25 ±2°C	b) Humidity: 60 - 70%	c) Pressure: 860-1060 mbar

**Packaging**

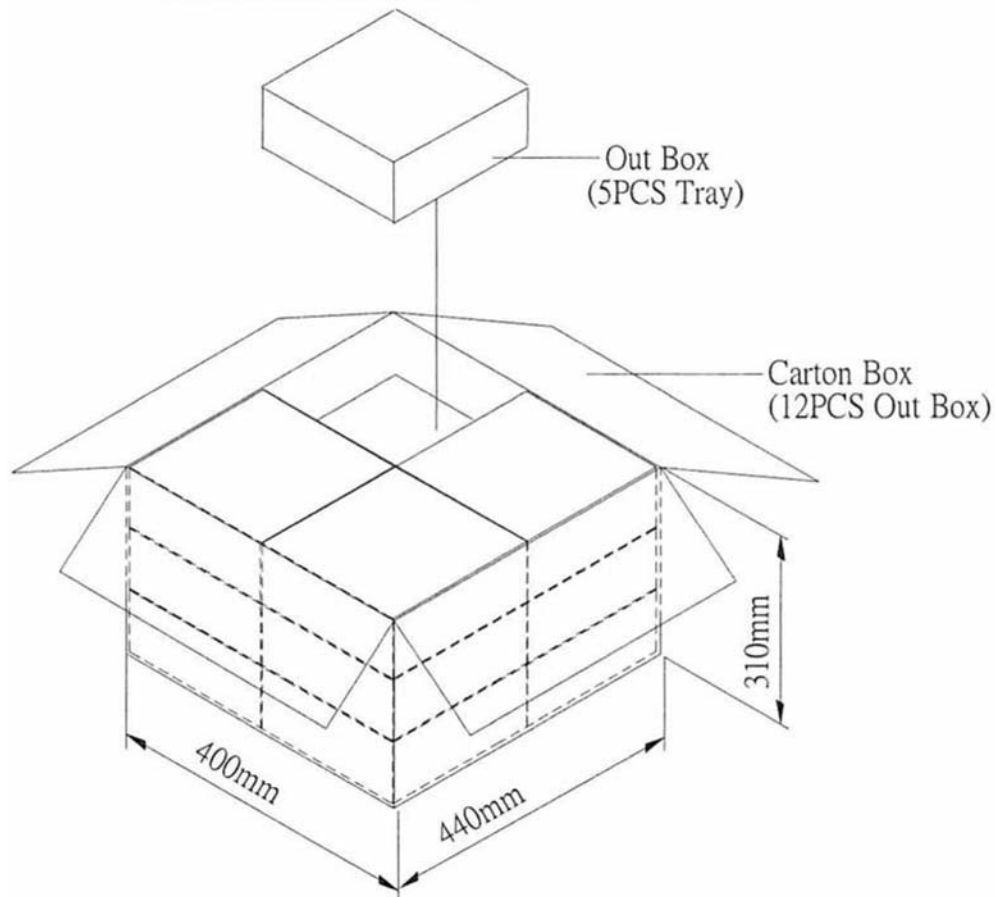
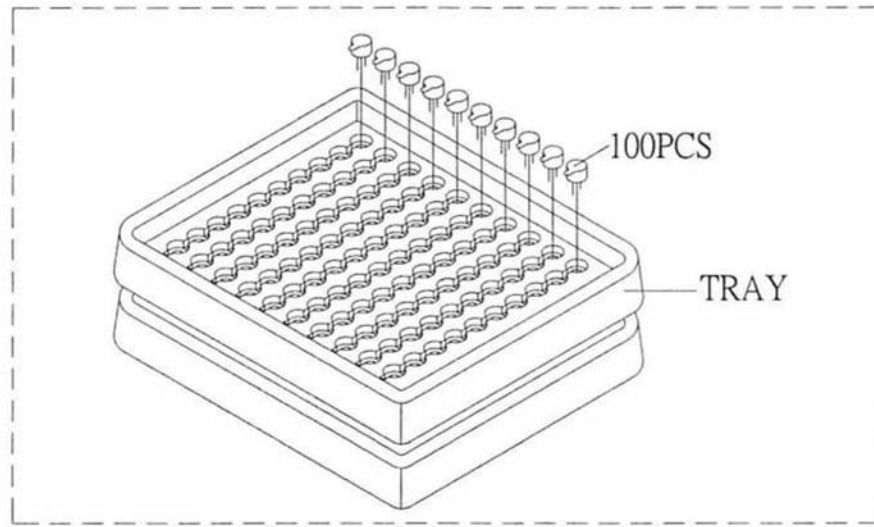

Tray	184mmx184mmx23mm	1x100PCS=100PCS
Out Box	200mmx190mmx100mm	5LAYERx100PCS=500PCS
Carton Box	440mmx400mmx310mm	500PCSx12=6000PCS