

RGBHV Driver with EMI Suppression

General Description

The MAX9511 provides a complete VGA interface between a graphics controller and/or docking station. The MAX9511 has output drivers with variable electromagnetic interference (EMI) suppression for graphics video and sync (RGBHV) signals and includes external load-detection circuitry.

The MAX9511 suppresses EMI emissions by limiting the slew rate (SR) rather than limiting bandwidth with fixed L-C filters. The SR controls the large-signal bandwidth without affecting the small-signal bandwidth, resulting in sharper video images, while reducing EMI. The SR of the MAX9511 provides tighter control than traditional passive L-C components, and allows the SR to track the resolution by varying an external resistor (R_{FX}) rather than being fixed to a sub-optimal value.

The load-detection circuitry of the MAX9511 automatically detects and transmits a change in load status to the input stages when an external load (monitor, docking station, or projector) is connected. The MAX9511 is compatible with the load-detection circuitry on the digital-to-analog (DAC) outputs of most video graphics controllers. The output drivers provide 6dB of gain to compensate for the 75Ω back-termination resistors, which reduce transmission line reflections.

The RGBHV channels can be placed into shutdown to reduce power when no external load is connected.

The MAX9511 operates from 3V and 5V supplies. The DDC circuitry performs bidirectional level translation from 3V to 5V logic levels. The MAX9511 is offered in a 24-pin QSOP package and is specified over the commercial 0°C to +70°C temperature range.

Applications

- Notebook PCs (Laptops)
- Docking Stations
- Graphics Cards for Notebooks and Personal Computers
- Personal Computer Motherboards with On-Board Video Graphics Controllers
- Workstations

Pin Configuration appears at end of data sheet.

Features

- ◆ RGB Drivers with Adjustable Slew Rate for EMI Control
- ◆ H Sync and V Sync Drivers with Level Translation
- ◆ Bidirectional Level Translators for DDC Support
- ◆ Simultaneously Drives External Monitor/Projector and Docking Station without Analog RGB Switches—No Stub Reflections
- ◆ Eliminates Up to 34 External Components
- ◆ Small 24-Pin QSOP Package

Ordering Information

PART	TEMP RANGE	PIN-PACKAGE	PKG CODE
MAX9511CEG	0°C to +70°C	24 QSOP	E24-2
MAX9511CEG+	0°C to +70°C	24 QSOP	E24-2

+Denotes a lead-free package.

Simplified Block Diagram

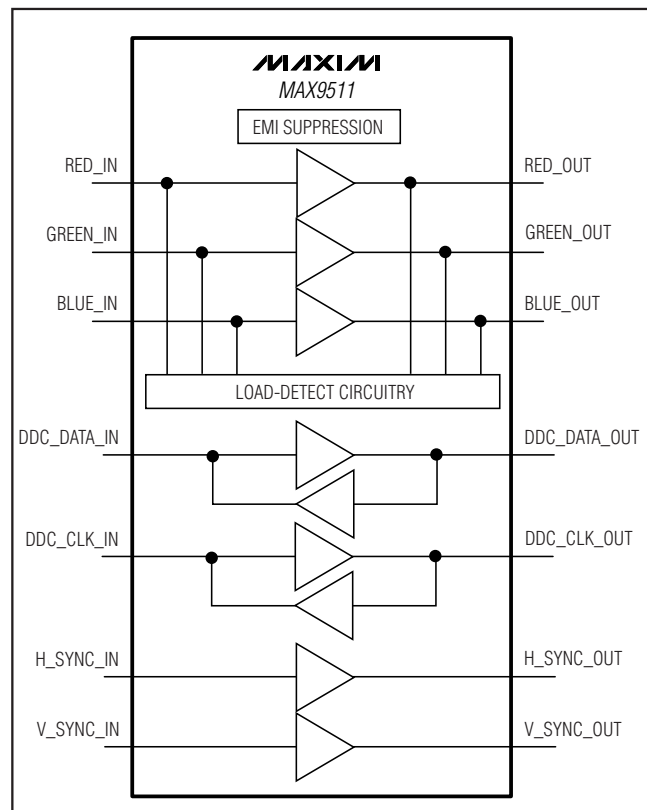

RGBHV Driver with EMI Suppression

MAX9511

ABSOLUTE MAXIMUM RATINGS

V _{CC} to AGND.....	-0.3V to +6V	DDC_DATA_OUT	
V _{DD1} , V _{DD2} to DGND	-0.3V to +6V	to DGND	(DDC_DATA_IN - 0.1V) to (V _{DD1} + 0.3V)
DGND to AGND.....	-0.1V to +0.1V	DDC_CLK_IN	
RED_IN, GREEN_IN, BLUE_IN to AGND.....	-0.3V to (V _{CC} + 0.3V)	to DGND.....	(DDC_CLK_OUT - 0.3V) to (V _{DD2} + 0.3V)
RED_OUT, GREEN_OUT, BLUE_OUT		DDC_CLK_OUT	
to AGND	-0.3V to (V _{CC} + 0.3V)	to DGND.....	(DDC_CLK_IN - 0.1V) to (V _{DD1} + 0.3V)
RX to AGND.....	-0.3V to (V _{CC} + 0.3V)	DDC_DATA_OUT to DDC_DATA_IN.....	-0.1V to +6V
H_SYNC_IN, V_SYNC_IN, SHDN		DDC_CLK_OUT to DDC_CLK_IN.....	-0.1V to +6V
to DGND	-0.3V to (V _{DD2} + 0.3V)	Continuous Power Dissipation (T _A = +70°C)	
H_SYNC_OUT, V_SYNC_OUT		24-Pin QSOP (derate 9.5mW/°C above +70°C).....	762mW
to DGND	-0.3V to (V _{DD1} + 0.3V)	Operating Temperature Range.....	0°C to +70°C
DDC_DATA_IN		Storage Temperature Range	-65°C to +150°C
to DGND.....	(DDC_DATA_OUT - 0.3V) to (V _{DD2} + 0.3V)	Lead Temperature (soldering, 10s).....	+300°C

Stresses beyond those listed under "Absolute Maximum Ratings" may cause permanent damage to the device. These are stress ratings only, and functional operation of the device at these or any other conditions beyond those indicated in the operational sections of the specifications is not implied. Exposure to absolute maximum rating conditions for extended periods may affect device reliability.

ELECTRICAL CHARACTERISTICS

(V_{CC} = 5V, V_{DD1} = 5V, V_{DD2} = SHDN = 3V, R_L = 150Ω to AGND, DGND = AGND, R_{RX} = 7kΩ to AGND, T_A = 0°C to +70°C. Typical values are at T_A = +25°C.)

PARAMETER	SYMBOL	CONDITIONS	MIN	TYP	MAX	UNITS
Supply Voltage Range	V _{CC}	Inferred from PSRR	4.5		5.5	V
	V _{DD1}	Inferred from logic test	4.5		5.5	
	V _{DD2}	Inferred from logic test	2.3		3.6	
Quiescent Supply Current	I _{CC}	SHDN = V _{DD2}		38	50	mA
		R _{RX} = 7kΩ				
	R _{RX} = 36kΩ		25	35		
	SHDN = DGND		0.15	0.25		
	I _{DD1}	SHDN = V _{DD2}		3	6	
		SHDN = DGND		0.027	0.08	
I _{DD2}	SHDN = V _{DD2}		220	500	μA	
	SHDN = DGND		26	40		
VIDEO						
Input Voltage Range	V _{IN}	Inferred from voltage gain	0	0.7	0.9	V
Output Black Level Voltage	V _{OUT, BLACK}	RED_IN = GREEN_IN = BLUE_IN = AGND	5	65	160	mV
Voltage Gain	A _V	0 ≤ V _{IN} ≤ 0.9V, R _L = 75Ω	+1.9	+2	+2.1	V/V
Gain Matching	ΔA _V	0 ≤ V _{IN} ≤ 0.9V, R _L = 75Ω		1	2	%
Input Resistance	R _{IN}	0 ≤ V _{IN} ≤ 1V, with load	10	100		kΩ
		0.4V ≤ V _{IN} ≤ 0.7V, no load	-85	-74	-62	Ω
Output Impedance	Z _{OUT}	f = 100kHz		0.64		Ω
Output Short-Circuit Current (To AGND)	I _{OUT}			40		mA
Load-Detection Voltage	V _{X_IN}	(Note 1)			0.2	V
Output Load Detection	R _{L_OUT}	V _{IN} = 0.4V	180			Ω
Power-Supply Rejection	PSRR	4.5V ≤ V _{CC} ≤ 5.5V, V _{IN} = 0.5V	40	57		dB
Large-Signal Bandwidth		V _{OUT} = 1.6V _{P-P} , R _{RX} = 7kΩ		370		MHz

RGBHV Driver with EMI Suppression

MAX9511

ELECTRICAL CHARACTERISTICS (continued)

(V_{CC} = 5V, V_{DD1} = 5V, V_{DD2} = $\overline{\text{SHDN}}$ = 3V, R_L = 150Ω to AGND, DGND = AGND, R_{RX} = 7kΩ to AGND, T_A = 0°C to +70°C. Typical values are at T_A = +25°C.)

PARAMETER	SYMBOL	CONDITIONS	MIN	TYP	MAX	UNITS
Slew Rate (Notes 2, 3)	SR	R _{RX} = 36kΩ, T _A = +25°C	250	330	450	V/μs
		R _{RX} = 7kΩ, T _A = +25°C	900	1100	1300	
Settling Time	t _S	(Notes 4, 5)		0		ns
Undershoot/Overshoot	t _{OS} , t _{US}			±1		%
Linearity Error	LE	V _{IN} = 700mV _{P-P} (Notes 6, 7)		0.036		%
Peak Signal-to-Noise Ratio	SNR	f = 100kHz to 100MHz, V _{IN} = 700mV _{P-P}		50		dB
Channel-to-Channel Skew	Δt	R to G to B (Note 3)		500	1100	ps
Power-Supply Rejection Ratio	PSRR	f = 100kHz		49		dB
Crosstalk		All hostile, f = 10MHz		55		dB
Input Termination Switch Delay	Δt _{SWD}			70		ns
LOGIC						
Input Low Level	V _{IL}	H_SYNC_IN, V_SYNC_IN and $\overline{\text{SHDN}}$			0.3 x V _{DD2}	V
Input High Level	V _{IH}	H_SYNC_IN, V_SYNC_IN and $\overline{\text{SHDN}}$	0.7 x V _{DD2}			V
Output Low Level	V _{OL}	I _{OL} = 4mA	H_SYNC_OUT, V _{H_SYNC_IN} = DGND		0.55	V
			V_SYNC_OUT, V _{V_SYNC_IN} = DGND			
		I _{OL} = 50μA	DDC_DATA_IN, V _{DDC_DATA_OUT} = DGND		0.4	
			DDC_CLK_IN, V _{DDC_CLK_OUT} = DGND			
I _{OL} = 3mA	DDC_DATA_OUT, V _{DDC_DATA_IN} = DGND		0.5			
	DDC_CLK_OUT, V _{DDC_CLK_IN} = DGND					
Output High Level	V _{OH}	I _{OH} = 4mA	H_SYNC_OUT, V _{H_SYNC_IN} = V _{DD2}	V _{DD1}	V	
			V_SYNC_OUT, V _{V_SYNC_IN} = V _{DD2}	- 1.5		
		I _{OH} = 50μA	DDC_DATA_IN, V _{DDC_DATA_OUT} = V _{DD1}	V _{DD2}		
			DDC_CLK_IN, V _{DDC_CLK_OUT} = V _{DD1}	- 0.4		
I _{OH} = 50μA	DDC_DATA_OUT, V _{DDC_DATA_IN} = V _{DD2}	V _{DD1}				
	DDC_CLK_OUT, V _{DDC_CLK_IN} = V _{DD2}	- 1.5				
SYNC Output Resistance	R _{SO}		35	55	85	Ω
$\overline{\text{SHDN}}$ Pulldown Resistance	R _{SD}		225	330	500	kΩ
SYNC Input Resistance	R _{SI}		30	47	70	kΩ
DDC Pullup Resistance	R _{PO}	DDC_DATA_OUT, DDC_CLK_OUT	2	3	4	kΩ
	R _{PI}	DDC_DATA_IN, DDC_CLK_IN	3.0	4.7	6.5	

RGBHV Driver with EMI Suppression

ELECTRICAL CHARACTERISTICS (continued)

($V_{CC} = 5V$, $V_{DD1} = 5V$, $V_{DD2} = \overline{SHDN} = 3V$, $R_L = 150\Omega$ to AGND, $DGND = AGND$, $R_{RX} = 7k\Omega$ to AGND, $T_A = 0^\circ C$ to $+70^\circ C$. Typical values are at $T_A = +25^\circ C$.)

PARAMETER	SYMBOL	CONDITIONS	MIN	TYP	MAX	UNITS
Rise/Fall Time	t_R/t_F	All SYNC outputs (Notes 2, 3)	$C_{SYNC} = 47pF$, $T_A = +25^\circ C$		7	ns
			$C_{SYNC} = 470pF$, $T_A = +25^\circ C$		50 70 100	
		DDC only, $C_L = 47pF$			400	
Propagation Delay	t_{PLH} , t_{PHL}	SYNC, $C_{SYNC} = 47pF$, $T_A = +25^\circ C$ (Notes 3, 8)		12	22	ns
Enable Time		$V_{IN} = 0.7V_{P-P}$, \overline{SHDN} from DGND to V_{DD2} , outputs settle to $\pm 1\%$ of final value		1200		ns
Disable Time		$V_{IN} = 0.7V_{P-P}$, \overline{SHDN} from V_{DD2} to DGND, outputs settle to $\pm 1\%$ of final value		400		ns

Note 1: This is the voltage at which the input termination switches; $V_{IN} > V_{X_IN}$ = switch open, $V_{IN} < V_{X_IN}$ = switch closed.

Note 2: Measured between the 10% to 90% points on rising or falling edge.

Note 3: Not production tested. Guaranteed by design.

Note 4: Measured from the END of overshoot/undershoot to $\pm 5\%$ of final value.

Note 5: $V_{IN} = 700mV$ with a rise time $> 1ns$.

Note 6: Linearity error is the maximum difference between the actual and measured output of a video ramp. Done in accordance with VESA Test Procedure, Version 1, 6/11/2001.

Note 7: Linearity error measured as percentage of full scale.

Note 8: Propagation delay is the time difference between the $V_{DD2} / 2$ input crossing and the 1.4V output crossing.

Typical Operating Characteristics

($V_{CC} = 5V$, $V_{DD1} = 5V$, $V_{DD2} = 3V$, $R_L = 150\Omega$ to AGND, $R_{RX} = 7k\Omega$ to AGND, $T_A = +25^\circ C$, unless otherwise noted.)

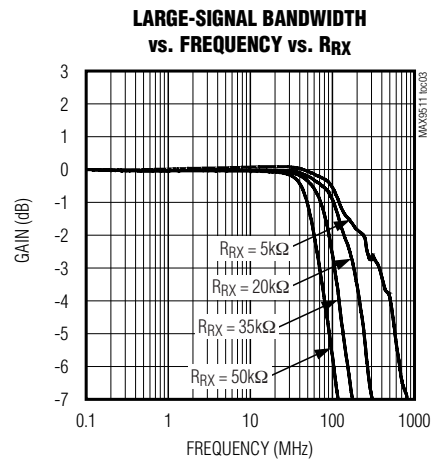
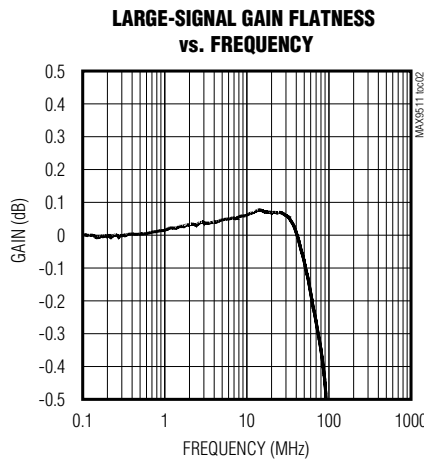
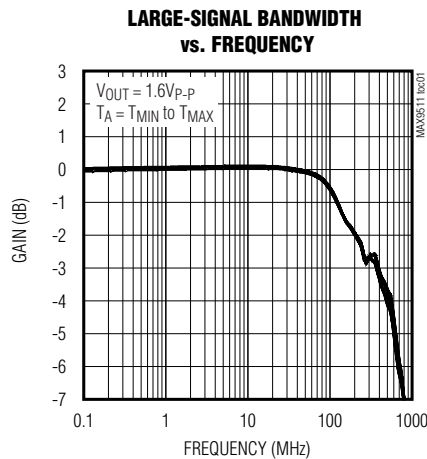

RGBHV Driver with EMI Suppression

MAX9511

Typical Operating Characteristics (continued)

($V_{CC} = 5V$, $V_{DD1} = 5V$, $V_{DD2} = 3V$, $R_L = 150\Omega$ to AGND, $R_{RX} = 7k\Omega$ to AGND, $T_A = +25^\circ C$, unless otherwise noted.)

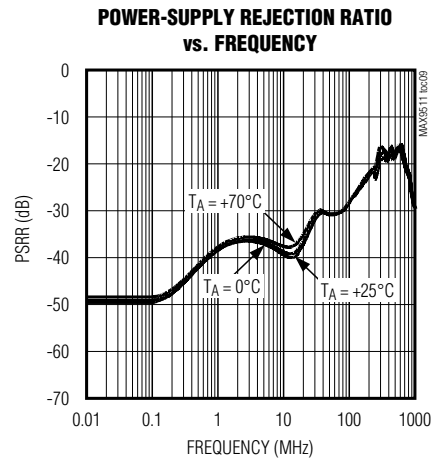
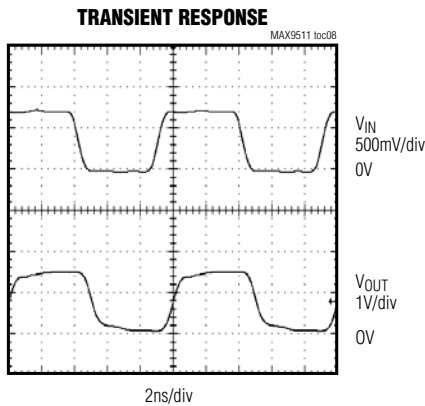
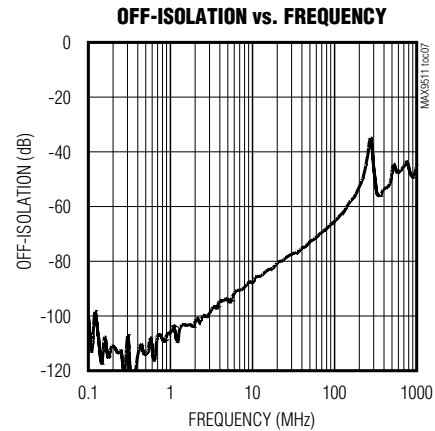
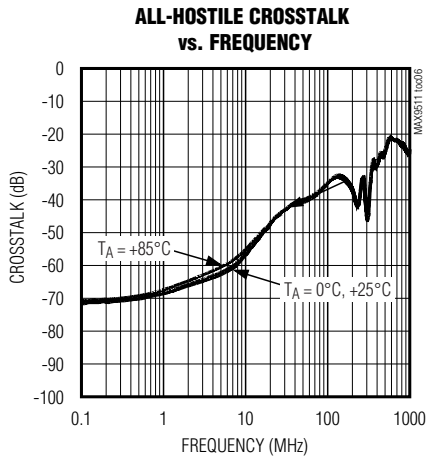
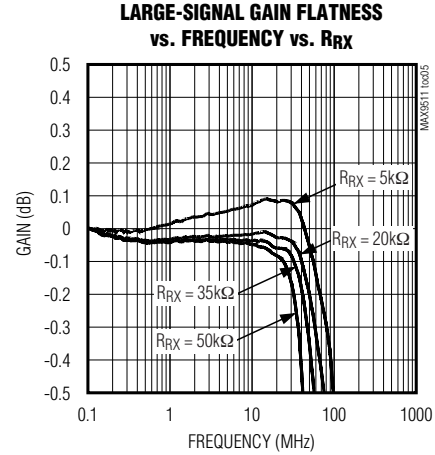
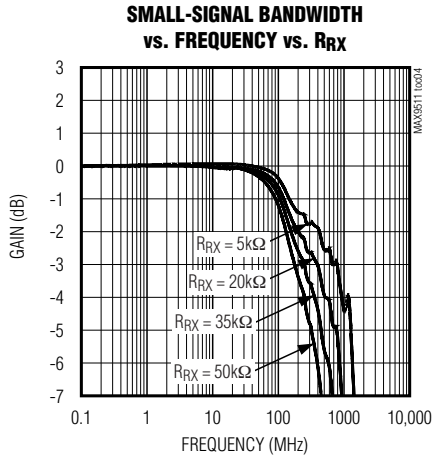

RGBHV Driver with EMI Suppression

Typical Operating Characteristics (continued)

(VCC = 5V, VDD1 = 5V, VDD2 = 3V, RL = 150Ω to AGND, RRX = 7kΩ to AGND, TA = +25°C, unless otherwise noted.)

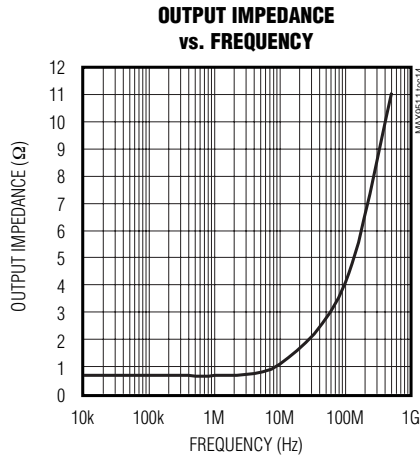
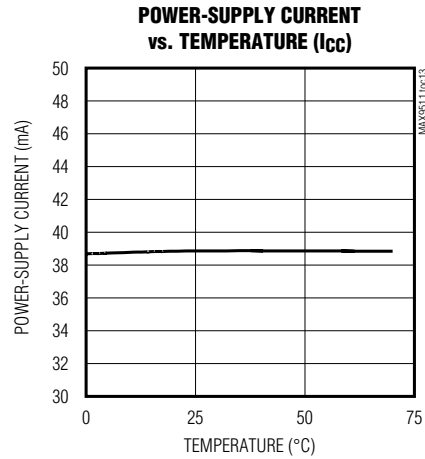
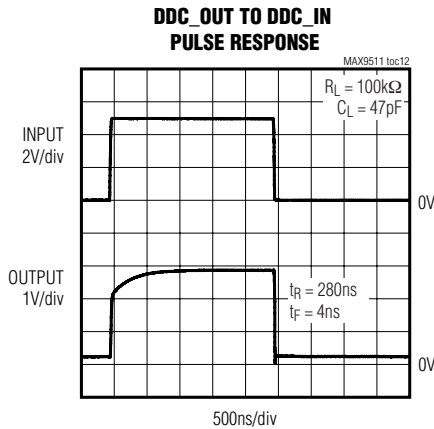
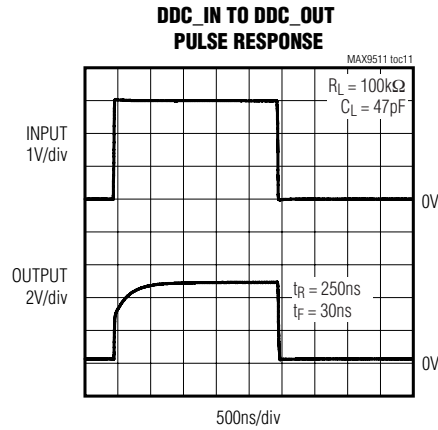
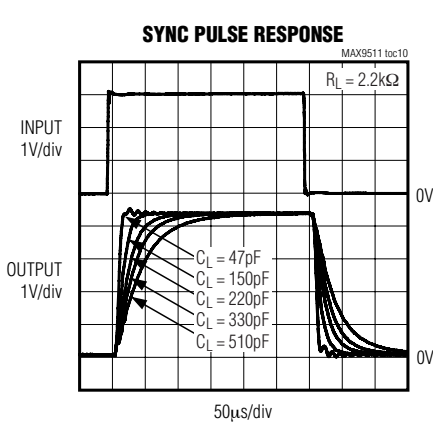

RGBHV Driver with EMI Suppression

MAX9511

Typical Operating Characteristics (continued)

($V_{CC} = 5V$, $V_{DD1} = 5V$, $V_{DD2} = 3V$, $R_L = 150\Omega$ to AGND, $R_{RX} = 7k\Omega$ to AGND, $T_A = +25^\circ C$, unless otherwise noted.)

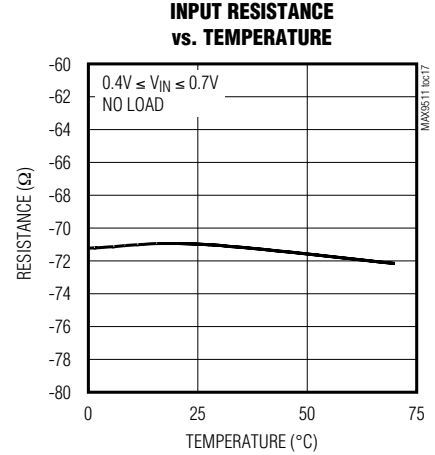
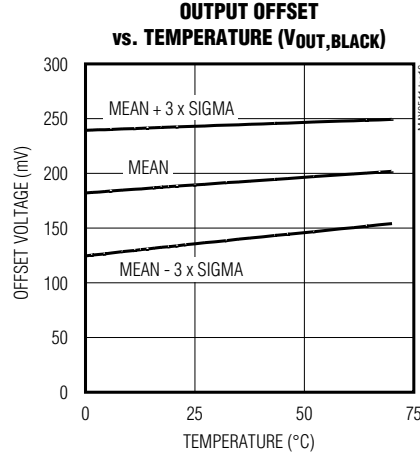
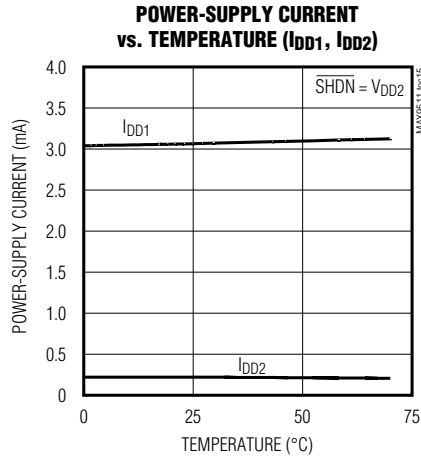

Pin Description

PIN	NAME	FUNCTION
1	V_{CC}	Analog Power Supply
2	GREEN_IN	Green Video Input
3, 20, 22, 24	AGND	Analog Ground
4	RED_IN	Red Video Input
5	BLUE_IN	Blue Video Input
6	RX	Slew-Rate Control. Connect an external resistor from RX to AGND.
7	\overline{SHDN}	Active-Low Shutdown. For normal operation connect to V_{DD2} . \overline{SHDN} is internally pulled to DGND.
8	DDC_DATA_IN	DDC Data Input. Defaults to V_{DD2} through an internal pullup resistor.
9	DDC_CLK_IN	DDC Clock Input. Defaults to V_{DD2} through an internal pullup resistor.
10	H_SYNC_IN	Horizontal SYNC Input. Defaults to AGND through an internal pulldown resistor.
11	V_SYNC_IN	Vertical SYNC Input. Defaults to AGND through an internal pulldown resistor.
12	V_{DD2}	SYNC/DDC 3V Supply
13	V_{DD1}	SYNC/DDC 5V Supply. Supplies 5V to SYNC and DDC output circuitry.
14	V_SYNC_OUT	Vertical Sync Output
15	H_SYNC_OUT	Horizontal Sync Output
16	DDC_CLK_OUT	DDC Clock Output. Defaults to V_{DD1} through an internal pullup resistor.
17	DDC_DATA_OUT	DDC Data Output. Defaults to V_{DD1} through an internal pullup resistor.
18	DGND	Digital Ground
19	BLUE_OUT	Blue Video Output
21	RED_OUT	Red Video Output
23	GREEN_OUT	Green Video Output

RGBHV Driver with EMI Suppression

Block Diagram

Detailed Description

MAX9511

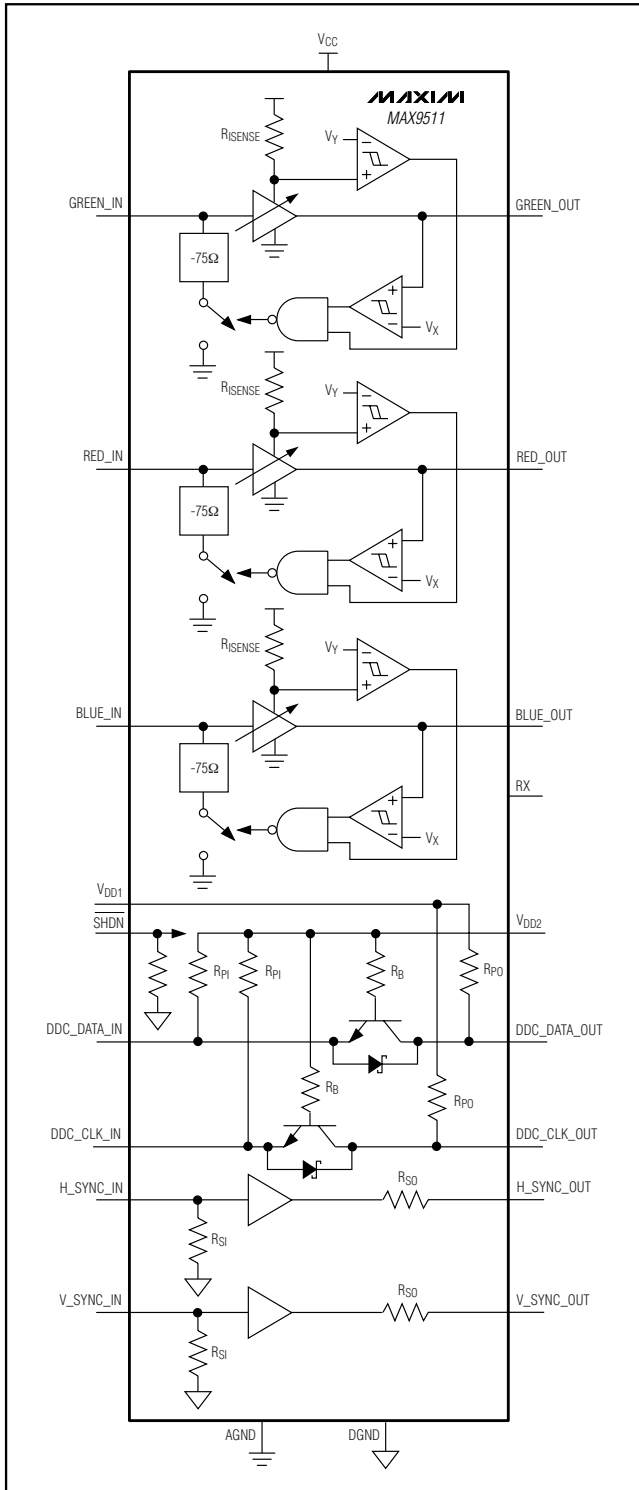

The MAX9511 solves several difficult problems in interfacing a video graphics controller to a VGA port and/or the docking station connector. First, there is a trade-off between video quality and EMI. The usual method for reducing EMI is to insert a fixed-frequency LC π -filter between the video DAC output and the connector. Given the large component variation of the capacitors and inductors, the frequency response is sharply reduced to meet EMI requirements. As a result, video quality suffers making sharp transitions in the video soft. The MAX9511 video drivers have a variable slew rate, which limits electromagnetic emissions and can be adjusted by an external resistor. As a result, the slew rate of the MAX9511 can be varied to reduce electromagnetic emissions at a given resolution, maximizing video quality. Since the slew rate is variable and set by a resistor instead of fixed by capacitors and inductors, video performance and electromagnetic emissions are consistent during production.

The MAX9511 also has horizontal and vertical sync output drivers, bidirectional level translators for DDC support, and external load-detection circuits that correctly transfer information about the external load to the video graphics controller.

Load Detection

Most notebook computers implement a power-saving load-detection circuit that disables the external monitor output when no monitor is plugged into the rear panel VGA connector as shown in Figure 1. Upon startup or on command, the video controller generates a sequence of detection pulses out of the current DAC shown, that results in an output voltage of above 315mV when an external monitor (R_L) is connected, and above 630mV when disconnected. If the monitor is disconnected at the time of the pulse, the comparator inside the notebook trips and disables the video. When the monitor is plugged in, the resulting pulse will not trip the comparator and the video is enabled.

If the lowpass filter is simply replaced with an amplifier, the monitor termination R_L is isolated from the video controller and the conventional load-detection scheme does not work.

For this reason, the MAX9511 includes the load-detection circuit. When R_L is connected (i.e., the monitor is plugged in) to the output of the MAX9511, the internal load-detection circuit disconnects the synthesized -75Ω resistor from the input. The resulting 37.5Ω resistance at the DAC output indicates to the DAC's internal load-detection circuit that the monitor is plugged in. Removing R_L (i.e., disconnecting the monitor) causes the MAX9511's load-detection circuit to connect the synthesized -75Ω

RGBHV Driver with EMI Suppression

MAX9511

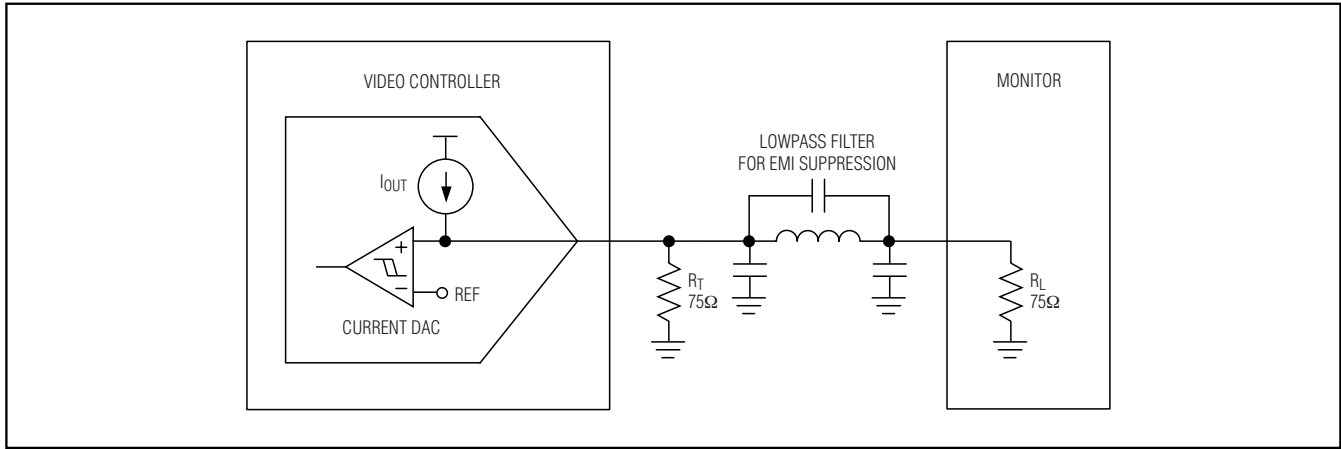

Figure 1. Conventional Load-Detection Scheme

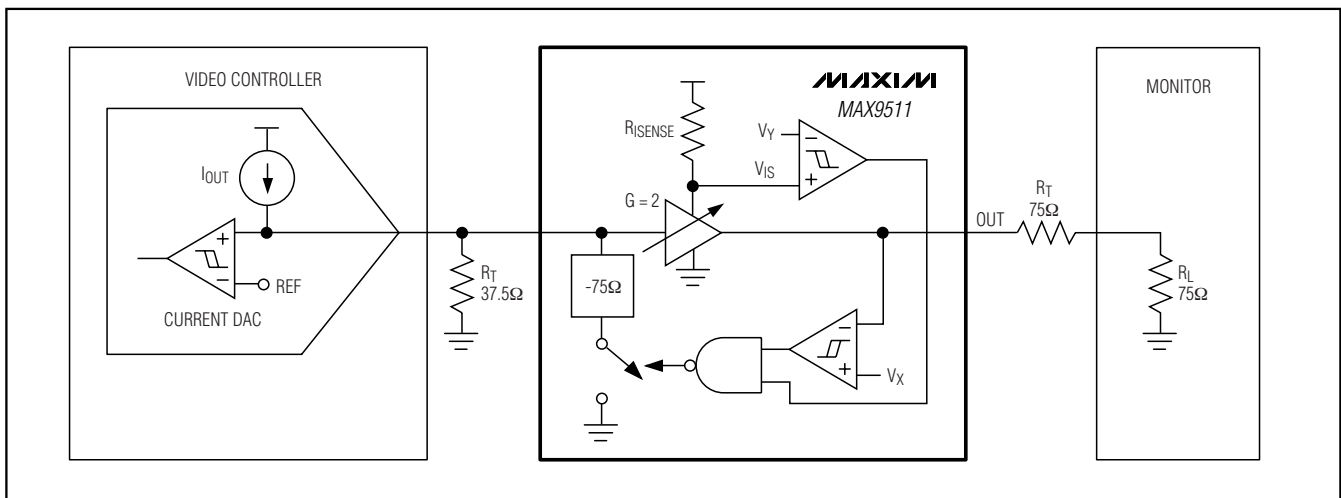

Figure 2. Load-Detection Scheme with MAX9511

resistor to the input. This results in an equivalent impedance of 75Ω at the DAC output, which indicates to the video controller's internal load-detection circuit that the load is disconnected and the video controller shuts down the video output. Figure 2 and Table 1 demonstrate how the MAX9511 load-detection circuit operates in conjunction with the video controller load detection.

Output Video Signal Level Shift

The video signal at the MAX9511 output is shifted upwards by approximately 240mV from the input to keep the output stage of the video driver in a linear region of operation. At the connector, the video signal is attenuated by 6dB, canceling the 6dB gain of the video driver. The 240mV level shift is also attenuated by

6dB, and hence the actual video signal seen by the load is only 120mV higher than the video signal at the input of the MAX9511. Monitors and other display devices AC-couple the input signal so the 120mV level shift should not affect the displayed video image.

Table 1. Function of Load-Detection Scheme

AMPLIFIER OUTPUT	MAX9511 INTERNAL SWITCH	RESISTANCE AT DAC OUTPUT
Connected to External Load	Open	37.5Ω
Not Connected to External Load	Closed	75Ω

RGBHV Driver with EMI Suppression

Vertical and Horizontal SYNC

The MAX9511 has separate, noninverting, vertical and horizontal sync buffers. Both sync inputs can level-shift an input as low as 2.3V to a 5V output. Both sync drivers have hysteresis at their input to prevent “chatter” in their outputs. The sync output drivers have a 55Ω (typ) output impedance (R_{SO}) to match the cable impedance used for vertical and horizontal sync in most applications. Both sync inputs are pulled to DGND through a 47kΩ resistor if the controller’s SYNC source goes high impedance, or if the inputs are left floating, avoiding ambiguous output conditions.

EMI can result from rapid transitions of the sync or the video signals. To reduce the rise and fall times of the sync signal, additional capacitance may be added to the sync outputs. Adding additional capacitance may require “recentering” the display.

Display Data Channel (DDC)

The MAX9511 bidirectional display data channel (DDC) level translator allows for a lower voltage video controller logic to operate with a higher voltage external monitor logic. Power supplied at V_{DD2} defines the DDC input voltage thresholds while power supplied at V_{DD1} defines the DDC output thresholds. Two Schottky-clamped npn transistors shift the lower level DDC inputs to higher logic-level outputs.

DDC_CLK_OUT and DDC_DATA_OUT are pulled to V_{DD1} by internal pullup resistors to prevent ambiguous conditions when left floating. At shutdown, DDC inputs can still respond to external commands.

Slew-Rate Limiting

The MAX9511 outputs are slew-rate limited to reduce EMI. Slew-rate limiting affects the large-signal bandwidth (LSBW) more than the small-signal bandwidth (SSBW), and can be scaled according to the following formula:

$$LSBW(-3dB) = \frac{SR}{2 \times \pi \times V_{OUT}}$$

where V_{OUT} is the output signal’s peak-to-peak voltage and $LSBW(-3dB)$ is the -3dB bandwidth.

The slew rate of the MAX9511 is controlled by a resistor between RX and AGND. The resistor (R_{RX}) can be varied to optimize the EMI suppression to the display resolution while preserving the display quality. The R_{RX} range is approximately 7kΩ for maximum slew rate and 50kΩ for minimum slew rate (see Figure 3). Slew-rate limiting can be approximated by:

$$SR = 1030 \left(\frac{7000}{R_{RX}} \right) (V/\mu s)$$

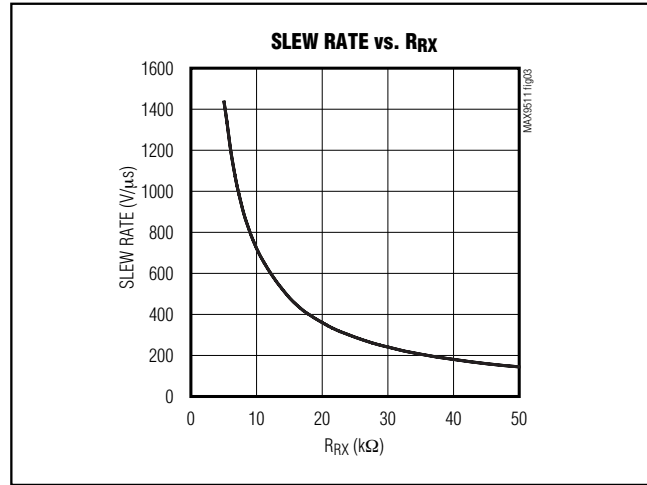

Figure 3. Slew Rate vs. R_{RX}

Shutdown

The MAX9511 features a low-power shutdown mode for battery-powered/portable applications. Shutdown reduces the quiescent current of the video and sync drivers. Connecting \overline{SHDN} to ground (DGND) disables the outputs and places the MAX9511 into a low-power shutdown mode. \overline{SHDN} has a 330kΩ (typ) internal pulldown resistor to DGND. Connect \overline{SHDN} to V_{DD2} for normal operation.

Applications Information

Customizing Slew Rates for Different Resolutions

When the MAX9511 connects to devices of different resolutions, different slew rates should be used. The slew rate of the MAX9511 is adjustable by varying R_{RX} between 7kΩ and 50kΩ. By selecting a valid R_{RX} value for a resolution, the MAX9511 minimizes the EMI and optimizes the video output quality. Shown are two configurations to adjust slew rates using different R_{RX} values for different video resolutions.

Figure 4 shows how to customize slew rates for three resolutions. This circuit provides three predetermined slew rates by paralleling resistors to create three R_{RX} values. The combination is controlled by a digital command from the video controller through a switch. This requires that the sample clock rates used by different resolutions are close. The sync bandwidth-limiting capacitors (C_{SYNC}) are set for the highest resolution.

RGBHV Driver with EMI Suppression

MAX9511

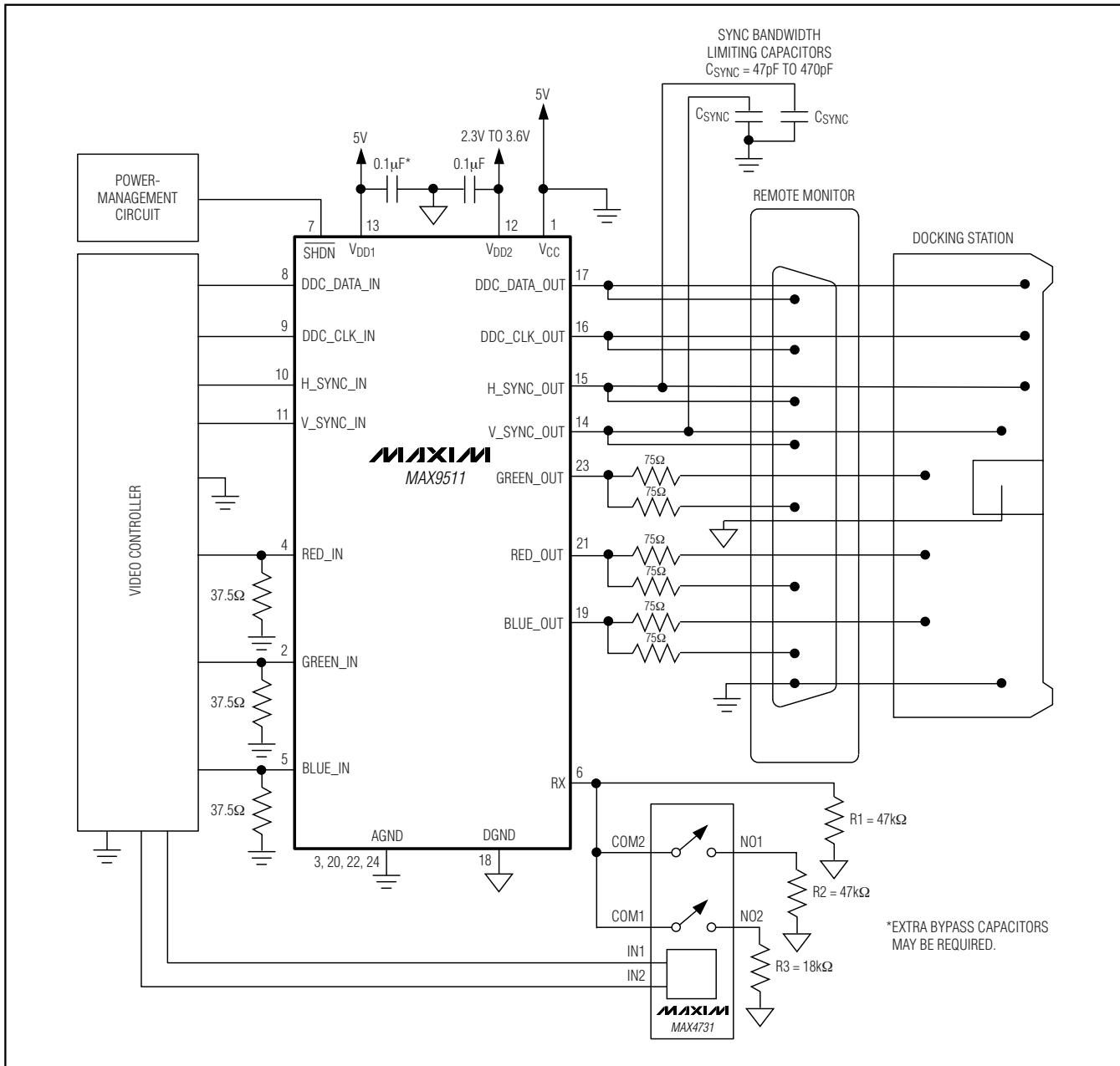

Figure 4. Three Resolution Slew-Rate Control

Figure 4 showcases the setup for three commonly used resolutions: 1600 x 1200, 1280 x 1024, and 1024 x 768. Since the resolution change is relatively slow, the switch does not have to be fast. The impedance of the switch does not need to be low compared to R_{RX} . When using a high-impedance switch, the resistance

from the switch should be included to calculate R_{RX} . The MAX4731 50Ω SPST analog switch shown in the figure is used with three external resistors to get R_{RX} values of 10kΩ, 23.5kΩ, and 47kΩ for 1600 x 1200, 1280 x 1024, and 1024 x 768 resolutions, respectively.

RGBHV Driver with EMI Suppression

MAX9511

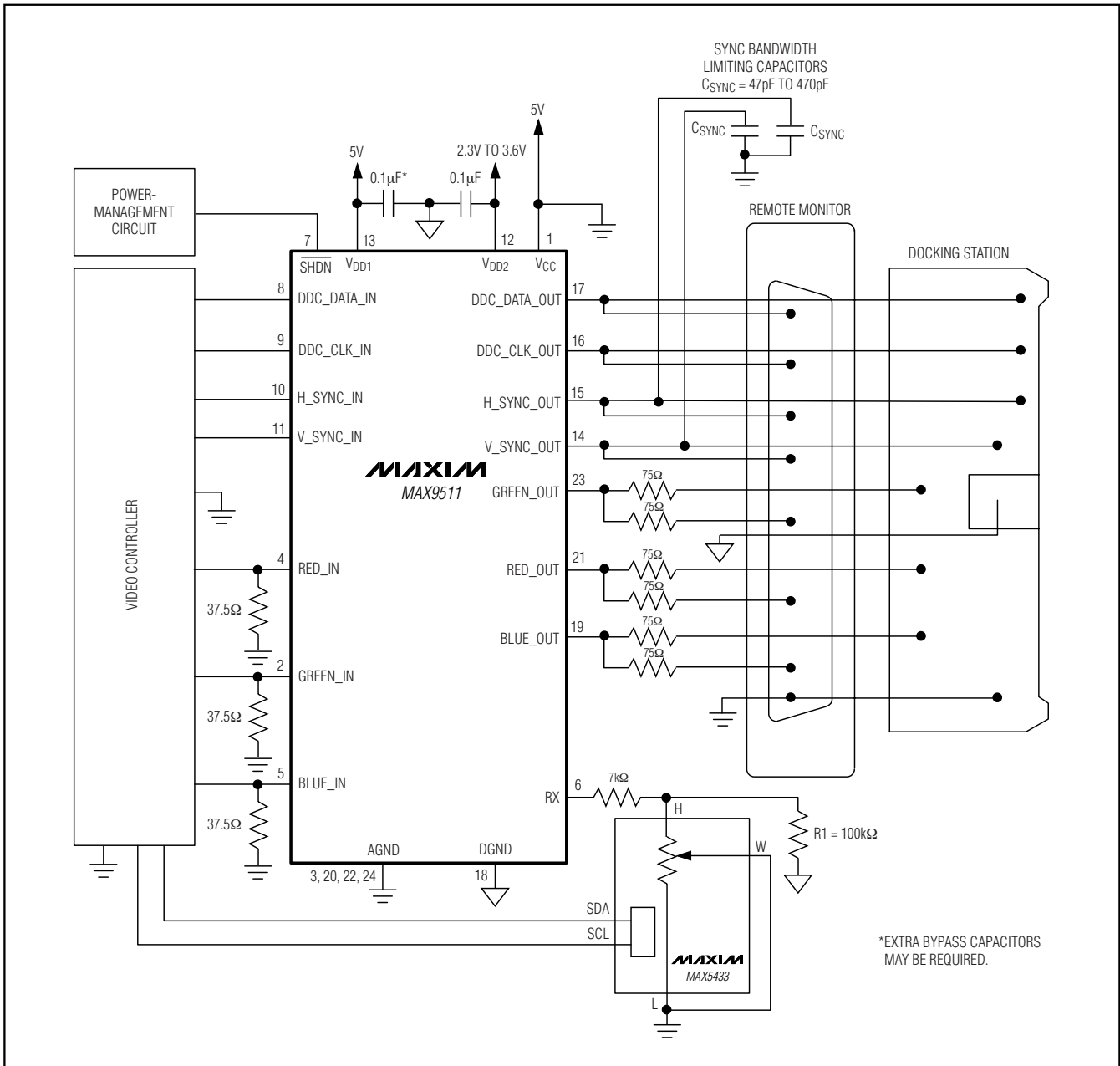

Figure 5. Slew-Rate Control with a Digital Potentiometer

The circuit in Figure 5 uses a MAX5433 digital potentiometer to provide more flexibility in customizing slew rates. An 100kΩ external trim resistor is placed in paral-

lel with the 100kΩ MAX5433 to limit the maximum value of R_{RX} to 50kΩ. This setup provides 33 levels of R_{RX} values through the I²C control ports at the MAX5433.

RGBHV Driver with EMI Suppression

MAX9511

Power Supplies

The MAX9511 operates with a 4.5V to 5.5V power supply for video (RGBHV), while DDC and SYNC operate from 2.3V to 3.6V and 4.5V to 5.5V supplies.

SYNC Bandwidth-Limiting Capacitors

The output impedance, R_{SO} , of the MAX9511 and an additional capacitance (C_{SYNC}) can form a lowpass filter that reduces the jitter of the sync output signal. With R_{SO} (55Ω typ) sync output impedance, the -3dB point of the lowpass filter is given by:

$$f_{-3dB} = \frac{1}{2\pi R_{SO} C_{SYNC}}$$

Choose C_{SYNC} so f_{-3dB} is well above the highest frequency of interest.

Power-Supply Bypassing and Ground Management

The MAX9511's high-frequency performance requires proper layout and bypassing. For best performance, place components as close to the device as possible.

Digital or AC transient signals on AGND can create noise at the outputs. Return AGND to the lowest impedance ground available. Bypass the analog supply (V_{CC}) with a 4.7μF capacitor paralleled with a 0.22μF and 0.001μF capacitor to AGND, placed as close to the device as possible. Bypass the digital supplies (V_{DD1} , V_{DD2}) with a 0.1μF capacitor to DGND, placed as close to the device as possible. Careful PC board ground layout minimizes crosstalk between the outputs.

Pin Configuration

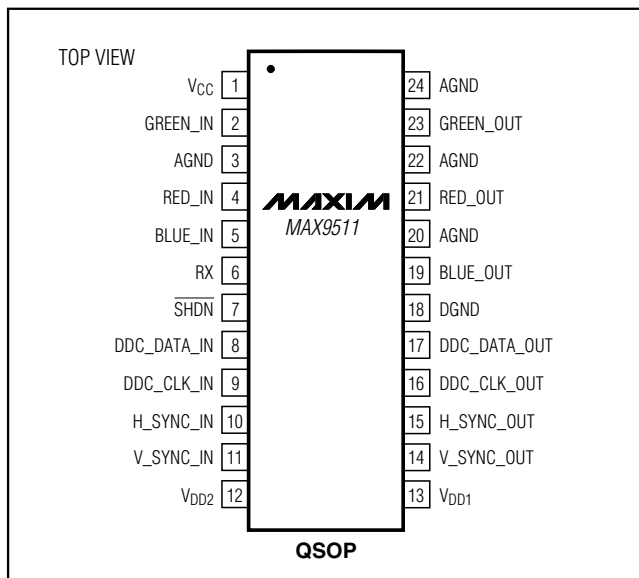

Chip Information

TRANSISTOR COUNT: 353
PROCESS: BIPOLAR

RGBHV Driver with EMI Suppression

MAX9511

Typical Operating Circuit

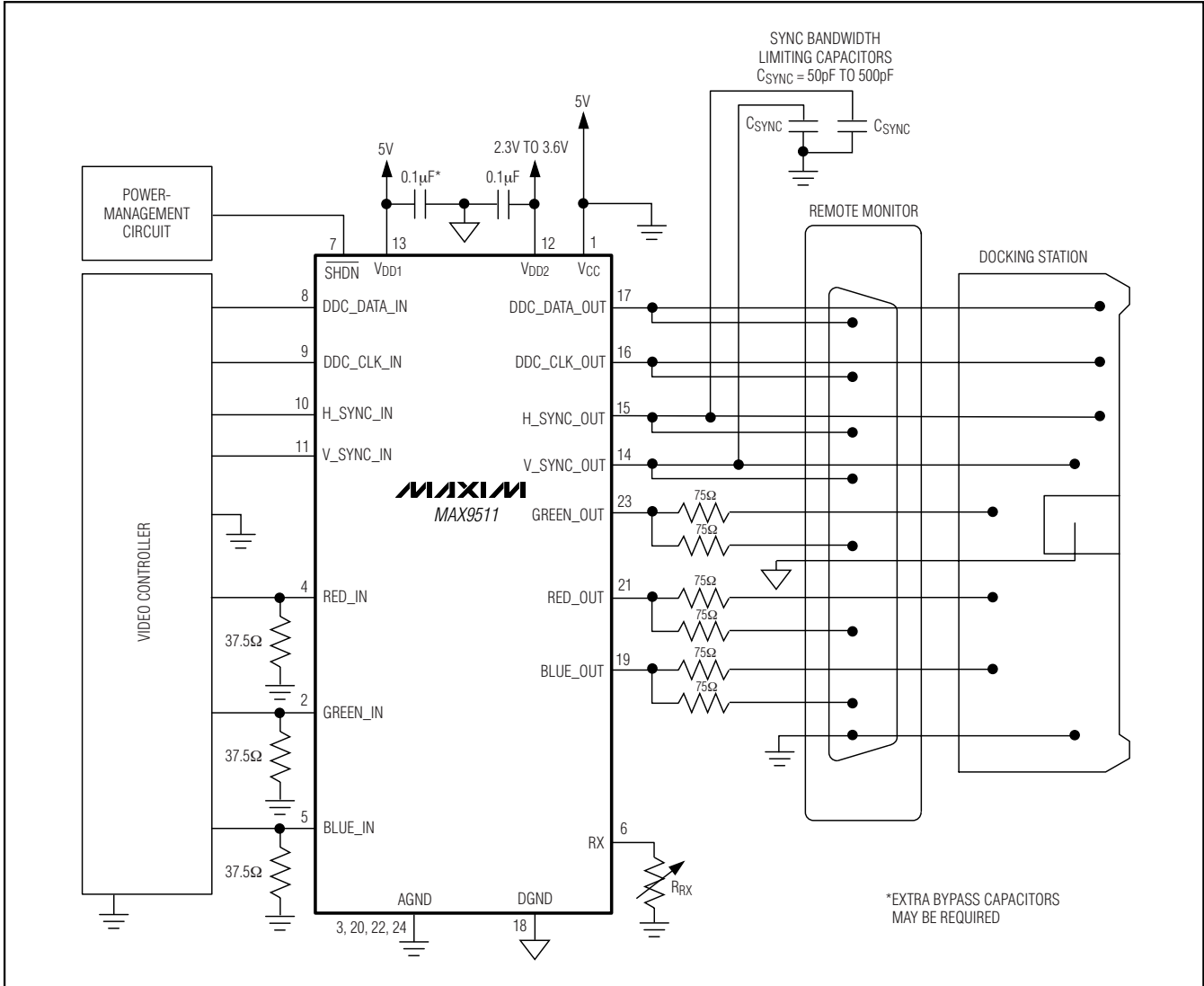

RGBHV Driver with EMI Suppression

Package Information

(The package drawing(s) in this data sheet may not reflect the most current specifications. For the latest package outline information, go to www.maxim-ic.com/packages.)

MAX9511

QSOP-EPS

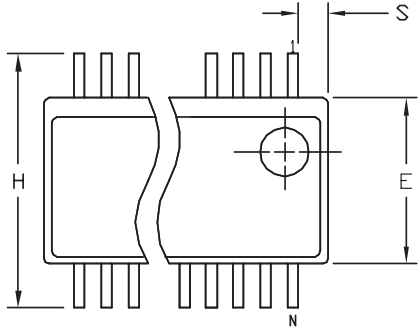

DIM	INCHES		MILLIMETERS	
	MIN	MAX	MIN	MAX
A	.053	.069	1.35	1.75
A1	.004	.010	.102	.254
A2	.049	.065	1.245	1.651
B	.008	.012	0.20	0.30
C	.0075	.0098	0.191	0.249
D	SEE VARIATIONS			
E	.150	.157	3.81	3.99
e	.025 BSC		0.635 BSC	
H	.230	.244	5.84	6.20
h	.010	.016	0.25	0.41
L	.016	.035	0.41	0.89
N	SEE VARIATIONS			
α	0°	8°	0°	8°

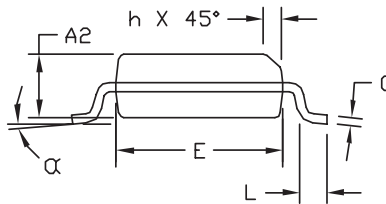
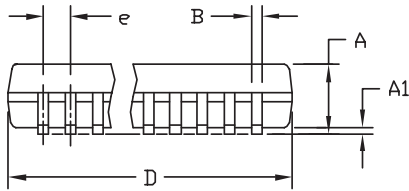

VARIATIONS:

DIM	INCHES		MILLIMETERS		N
	MIN.	MAX.	MIN.	MAX.	
D	.189	.196	4.80	4.98	16 AB
S	.0020	.0070	0.05	0.18	
D	.337	.344	8.56	8.74	20 AD
S	.0500	.0550	1.270	1.397	
D	.337	.344	8.56	8.74	24 AE
S	.0250	.0300	0.635	0.762	
D	.386	.393	9.80	9.98	28 AF
S	.0250	.0300	0.635	0.762	

NOTES:

- 1). D & E DO NOT INCLUDE MOLD FLASH OR PROTRUSIONS.
- 2). MOLD FLASH OR PROTRUSIONS NOT TO EXCEED .006" PER SIDE.
- 3). CONTROLLING DIMENSIONS: INCHES.
- 4). MEETS JEDEC MO137.

PROPRIETARY INFORMATION TITLE: PACKAGE OUTLINE, QSOP .150", .025" LEAD PITCH			
APPROVAL	DOCUMENT CONTROL NO.	REV.	1/1
	21-0055	F	

Revision History

Pages changed at Rev 3: 1, 6, 13, 15

Maxim cannot assume responsibility for use of any circuitry other than circuitry entirely embodied in a Maxim product. No circuit patent licenses are implied. Maxim reserves the right to change the circuitry and specifications without notice at any time.

Maxim Integrated Products, 120 San Gabriel Drive, Sunnyvale, CA 94086 408-737-7600 15