

Description

ACE1085 is a series of low dropout three terminal regulators with a dropout of 1.3V at 3A load current. Other than a fixed version ($V_{out}=1.8V, 2.5V, 3.3V, 5.0V$), ACE1085 has an adjustable version, The adjustable version can set the output voltage with two external resistors.

ACE1085 offers thermal shut down and current limit functions, to assure the stability of chip and power system. And it uses trimming technique to guarantee output voltage accuracy within $\pm 2\%$.

The ACE1085 series is available in standard packages of TO-263-2L, TO-263-3L, TO-220 and TO-252.

Features

- Other than a fixed version and an adjustable version, output value can be customized on command.
- Maximum output current is 3A
- Output voltage accuracy is within $\pm 2\%$ ($\pm 1\%$ Customized)
- Range of operation input voltage: Max 18V
- Line regulation: 0.2% (Typical)
- Load regulation: 0.2% (Typical)
- Environment Temperature: $-50^{\circ}\text{C} \sim 140^{\circ}\text{C}$

Application

- Power Management for Computer Mother Board, Graphic Card
- Battery Charger
- Post Regulators for Switching Supplies
- Microprocessor Supply

Absolute Maximum Ratings

Parameter	Symbol	Max	Unit
Input voltage	V_{IN}	18	V
Junction temperature	T_J	150	$^{\circ}\text{C}$
Environment Temperature	T_A	140	$^{\circ}\text{C}$
Storage temperature	T_S	- 65 to 150	$^{\circ}\text{C}$

Packaging Type

TO-220

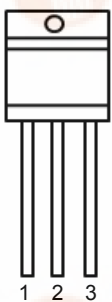

TO-263-3L

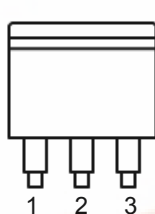

TO-263-2L

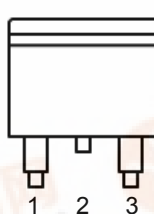

TO-252

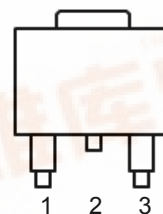

Fixed Version

Pin	Symbol	Definition
1	GND	Ground
2	Vout	Output
3	Vin	Input

Adjustable Version

Pin	Symbol	Definition
1	ADJ	Adjustable
2	Vout	Output
3	Vin	Input

Ordering information

Selection Guide

ACE1085 XX XX + H

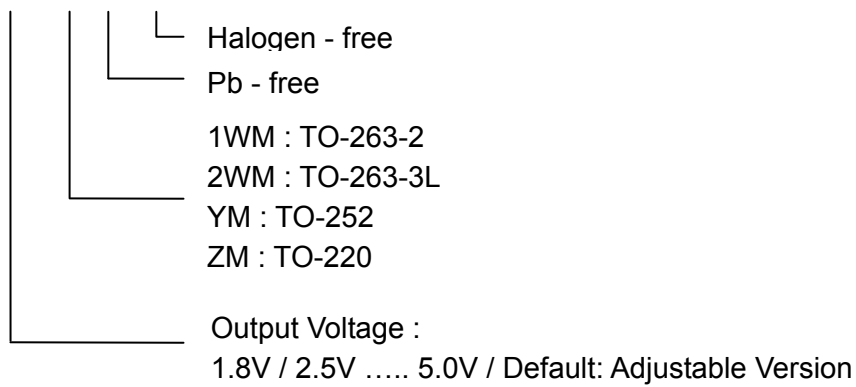

Block Diagram

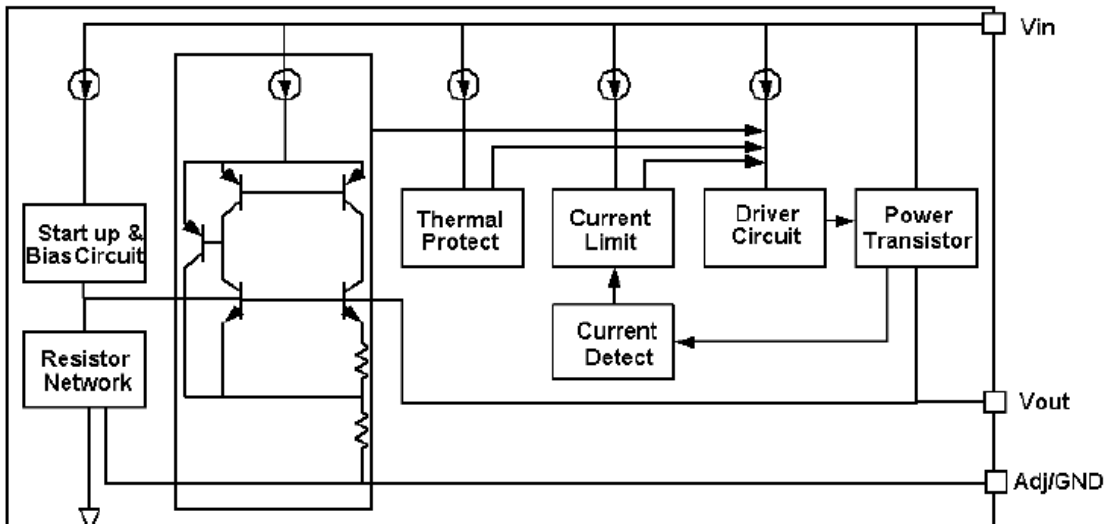

Recommended Work Conditions

Item	Min	Nom	Max	Unit
Input Voltage Range			18	V
Environment Temperature	-50		140	°C

Electrical Characteristics

T_J=25°C

Parameter	Symbol	Test Conditions	Min	Typ	Mum	Unit
Reference Voltage	V _{ref}	I _{out} =10mA, V _{in} -V _{out} =3V, 10mA≤I _{out} ≤3A, 1.5V≤V _{in} -V _{out} ≤5V	1.238 1.225	1.25 1.25	1.262 1.275	V
Output Voltage	V _{out}	ACE1085-1.80V, I _{out} =0mA, V _{in} =4.8V, T _J =25°C 10mA≤I _{out} ≤3A, 3.4V≤V _{in} ≤7V	1.782 1.764	1.80 1.80	1.818 1.836	V
		ACE1085-2.50V, I _{out} =0mA, V _{in} =4.8V, T _J =25°C 10mA≤I _{out} ≤3A, 4.1V≤V _{in} ≤7V	2.475 2.45	2.50 2.50	2.525 2.55	V
		ACE1085-3.3V, I _{out} =0mA, V _{in} =6.3V, T _J =25°C 10mA≤I _{out} ≤3A, 4.9V≤V _{in} ≤8V	3.267 3.234	3.3 3.3	3.333 3.366	V
		ACE1085-5.0V, I _{out} =0mA, V _{in} =8.0V, T _J =25°C 10mA≤I _{out} ≤3A, 6.6V≤V _{in} ≤10V	4.95 4.90	5.0 5.0	5.05 5.10	V
Line Regulation (Note1)	ΔV _{out}	ACE1085-ADJ, I _{out} =10mA, 2.85V≤V _{in} ≤10V		0.035	0.2	mV
		ACE1085-1.8V, I _{out} =10mA, 3.4V≤V _{in} ≤10V		1	5	mV
		ACE1085-2.5V, I _{out} =10mA, 4.1V≤V _{in} ≤10V		1	5	mV
		ACE1085-3.3V, I _{out} =10mA, 4.9V≤V _{in} ≤10V		1	5	mV
		ACE1085-5.0V, I _{out} =10mA, 6.6V≤V _{in} ≤10V		1	5	mV
Load Regulation (Note1,2)	ΔV _{out}	ACE1085-ADJ, V _{in} -V _{out} =3V, 10mA≤I _{out} ≤3A		0.2	0.4	%
		ACE1085-1.8V, V _{in} -V _{out} =3V, 0≤I _{out} ≤3A		3	15	mV
		ACE1085-2.5V, V _{in} -V _{out} =3V, 0≤I _{out} ≤3A		3	15	mV
		ACE1085-3.3V, V _{in} -V _{out} =3V, 0≤I _{out} ≤3A		3	15	mV
		ACE1085-5.0V, V _{in} -V _{out} =3V, 0≤I _{out} ≤3A		3	15	mV
Dropout Voltage (Note3)	V _{in} -V _{out}	ΔV _{out} , ΔV _{ref} = 1% · I _{out} =3A		1.3	1.5	V
Current Limit	I _{limit}	V _{in} -V _{out} =3V, T _J =25°C	3.2	4.5		A
Minimum Load Current (Note4)		ACE1085-ADJ		3	10	mV
Quiescent Current	I _q	V _{in} =10V		4	10	mV
Adjust Pin Current (Adjustable Version)	I _{Adj}	V _{in} =4.25V, I _{out} =10mA		45	110	uA
	Ripple Rejection	F=120Hz, C _{out} =25uF(tan), I _{out} =3A, V _{in} -V _{out} =3V				dB
Adjust Pin Current Change	I _{change}	10mA≤I _{out} ≤3A, 1.5V≤V _{in} -V _{out} ≤6V		0.2	5	uA
Temperature Stability		I _{out} =10mA, V _{in} -V _{out} =1.5V			0.5	%

Thermal Resistance junction to case	θ_{JC}	TO-252	12.5	$^{\circ}\text{C}/\text{W}$
		TO-263	3	
		TO-220	3	

Note1: The Parameters of Line Regulation and Load Regulation in Table1 are tested under constant junction temperature.

Note2: When I_{out} varies between 0~3A, $V_{in}-V_{out}$ varies between 1.5V~6V under constant junction temperature, the parameter is satisfied the criterion in table. If temperature varies between $-50^{\circ}\text{C} \leq T_A \leq 140^{\circ}\text{C}$, it needs output current to be larger than 10mA to satisfy the criterion.

Note3: Dropout Voltage is tested under $I_{out}=3\text{A}$ and the following testing conditions: First step is to find out the V_{out} value (V_{out1}) when $V_{in1}=V_{out}+1.5\text{V}$, second step is to decrease V_{in} (V_{in2}) until V_{out} value is equal to $99\% * V_{out1}$ (V_{out2}). $V_{dropout}=V_{in2}-V_{out2}$.

Note4: Minimum Load Current is defined as the minimum output current required to maintain regulation.

When $1.5\text{V} \leq V_{in}-V_{out} \leq 6\text{V}$, the device is guaranteed to regulate if the output current is greater than 10mA.

Detailed Description

ACE1085 is a series of low dropout voltage, three terminal regulators. Its application circuit is very simple: the fixed version only needs two capacitors and the adjustable version only needs two resistors and two capacitors to work. It is composed of some modules including start-up circuit, bias circuit, bandgap, thermal shutdown, current limit, power transistors and its driver circuit and so on.

The thermal shut down and current limit modules can assure chip and its application system working safety when the environment temperature is larger than 140°C or output current is larger than 3.2A.

The bandgap module provides stable reference voltage, whose temperature coefficient is compensated by careful design considerations. The temperature coefficient is under $100\text{ppm}/^{\circ}\text{C}$. And the accuracy of output voltage is guaranteed by trimming technique.

Typical Application Circuit

ACE1085 has an adjustable version and fixed versions, Chart 1 is its typical application.

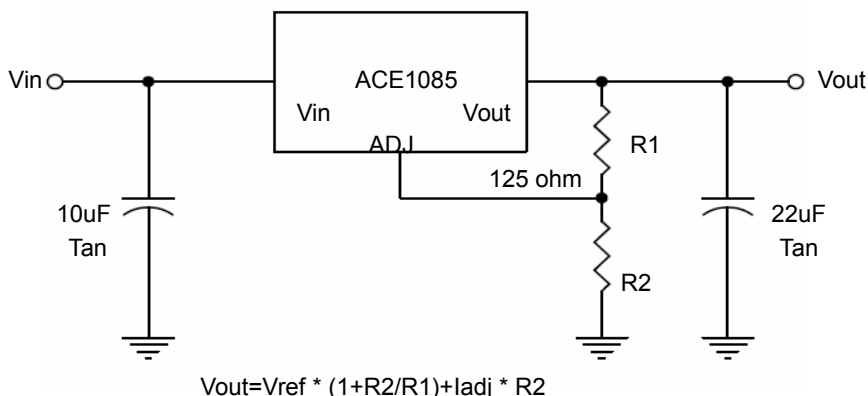

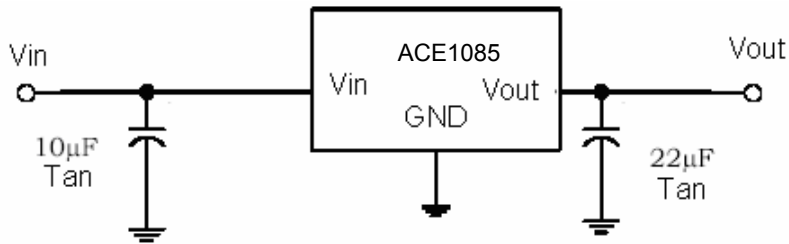

Typical application of ACE1085

Application Hints

1. Recommend using 10uF tan capacitor as bypass capacitor for all application circuit.
2. Recommend using 22uF tan capacitor to assure circuit stability.
3. Using a bypass capacitor(CAdj) between the adjust terminal and ground can improve ripple rejection, This bypass capacitor prevents ripple from being amplified as the output voltage is increased. The impedance of CAdj should be less than the resistor's(R1) which is between output and adjust pins to prevent ripple from being amplified at any ripple frequency. As R1 is normally in the range of 120Ω~200Ω,the value of CAdj should satisfy this equation: $2 * F_{ripple} * C_{Adj} < R1$. Recommend using 10uF tan capacitor.

Output Voltage of Adjustable Version

The ACE1085 adjustable version provide 1.25V Reference Voltage. Any output voltage between 1.25V~13.8V can be available by choosing two external resistors (connection method is shown in chart 1). In chart 1, R1,R2 is the two external resistors.

Explanation

The output voltage of adjustable version satisfies this followed equation:

$V_{out} = V_{Ref} * (1 + R2/R1) + I_{Adj} * R2$. We can ignore I_{Adj} because I_{Adj} (about 50uA) is much less than the current of R1(about 4mA).

How to choose R1 : The value of R1 should be in the range of 120Ω~200Ω to assure chip working normally without any load. To assure the electrical performance showed in table 1, the output current should be larger than 5mA. If R1 is too large, the minimum output current should be larger than 4mA , The best working condition is to assure that the output current exceeds 10mA.

Typical Performance Characteristic

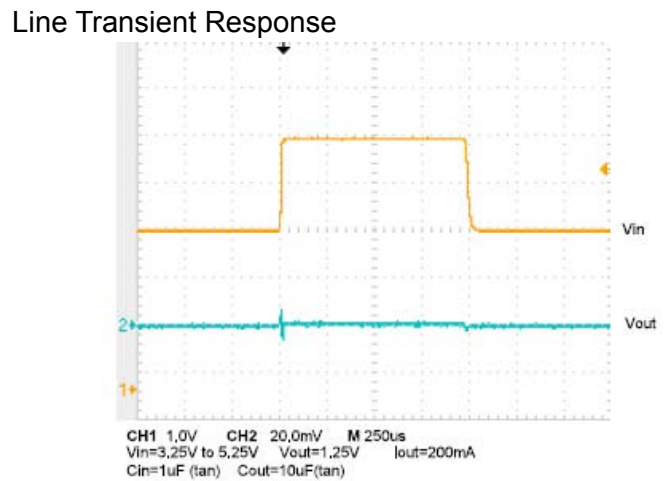
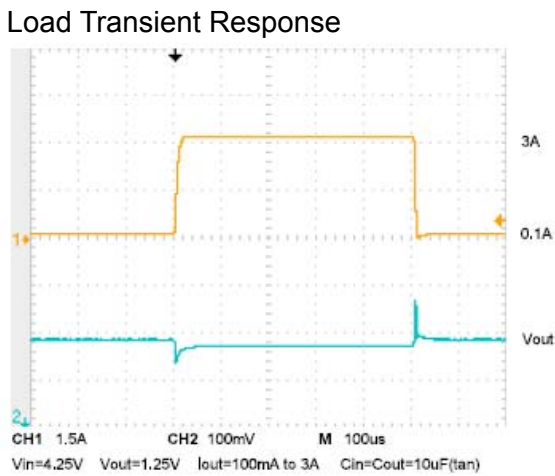
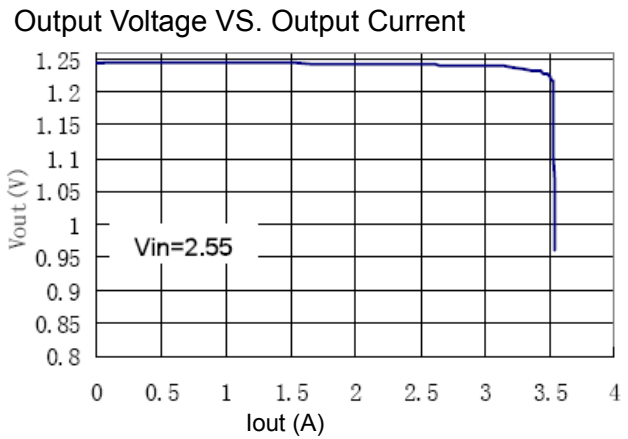
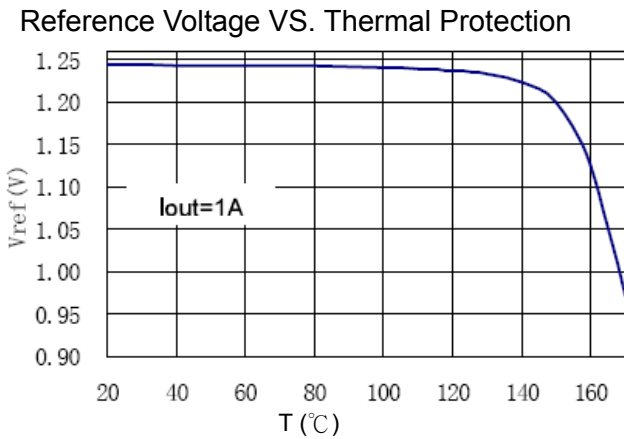
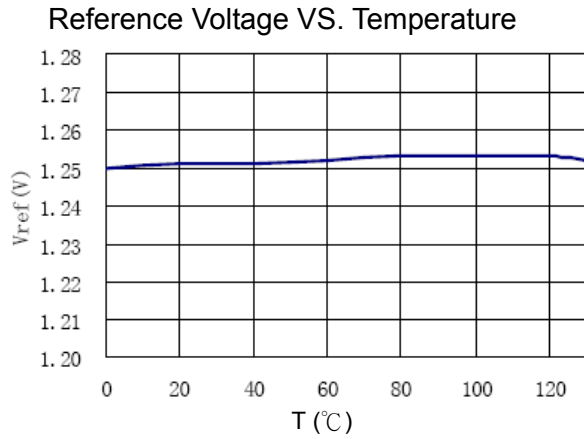
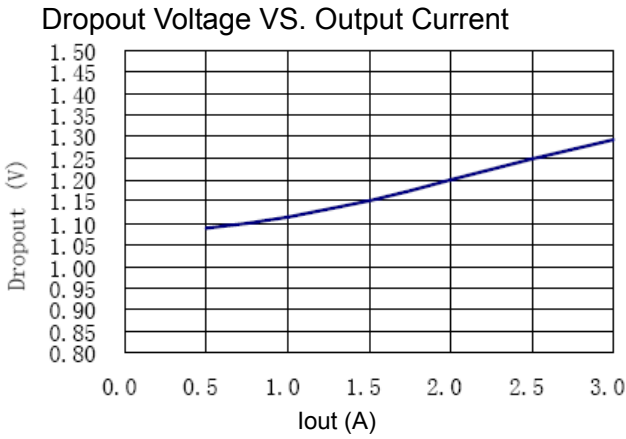

Packing Information

TO-252

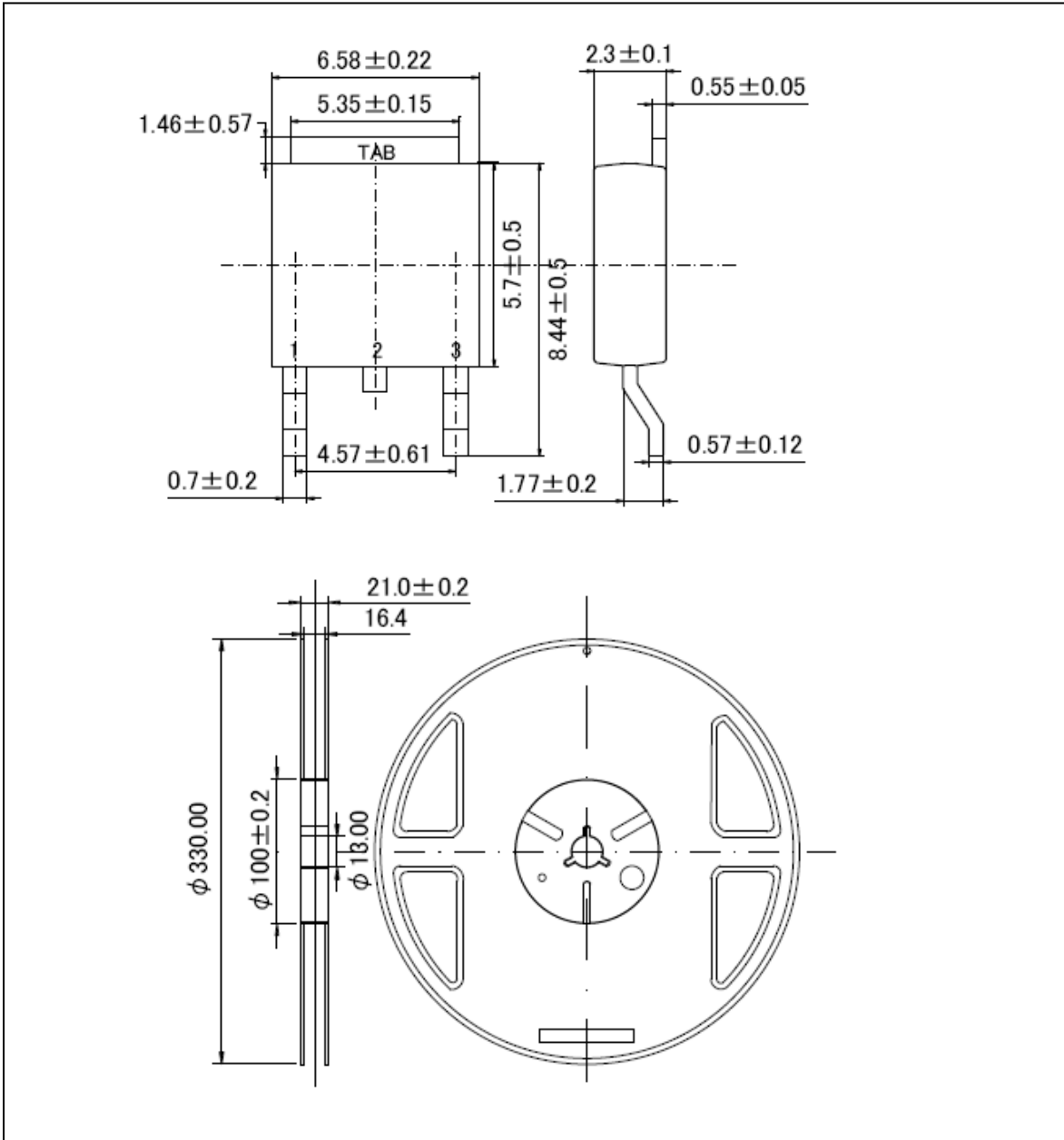

Packing Information

TO-220

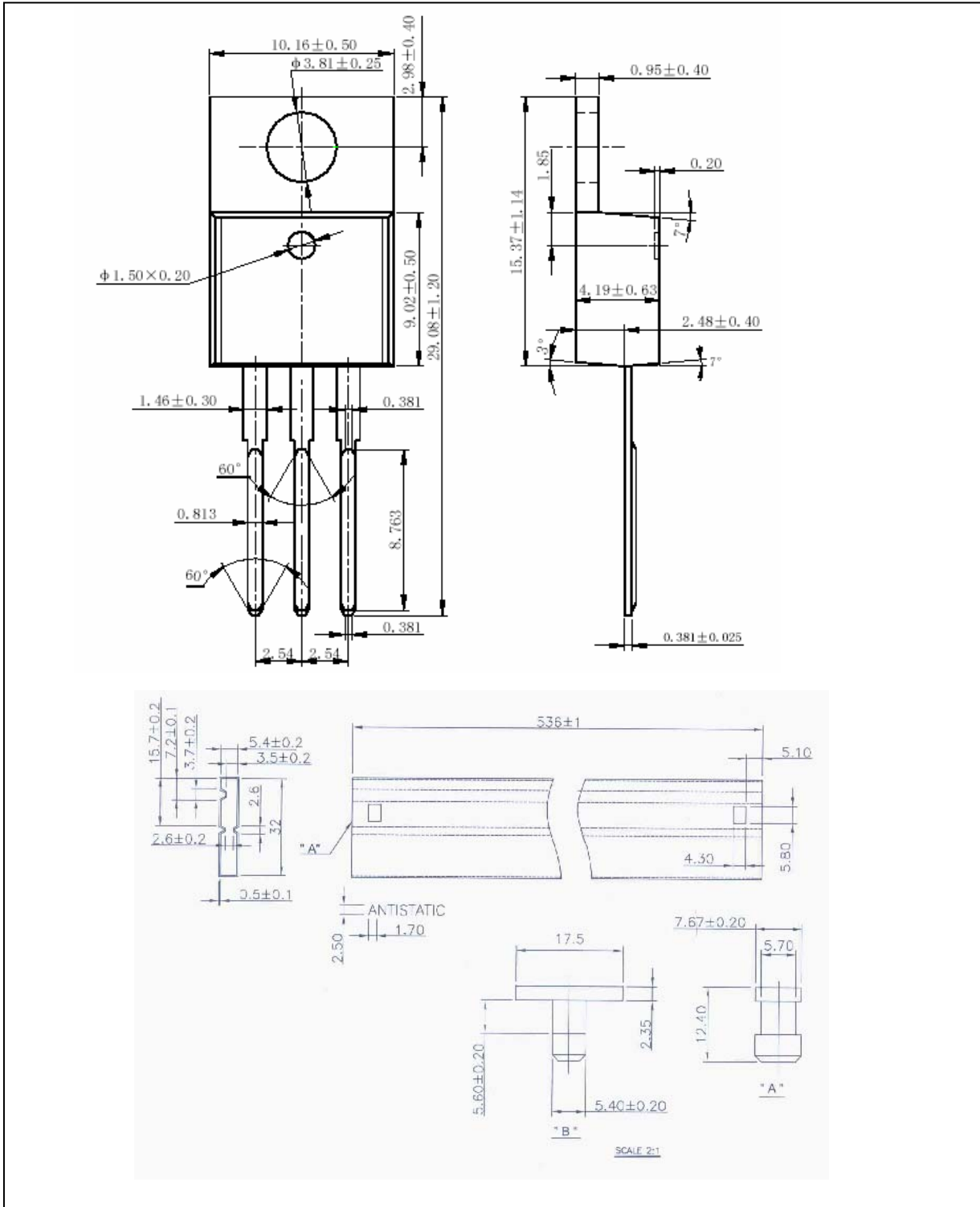

Packing Information

TO-263-2L

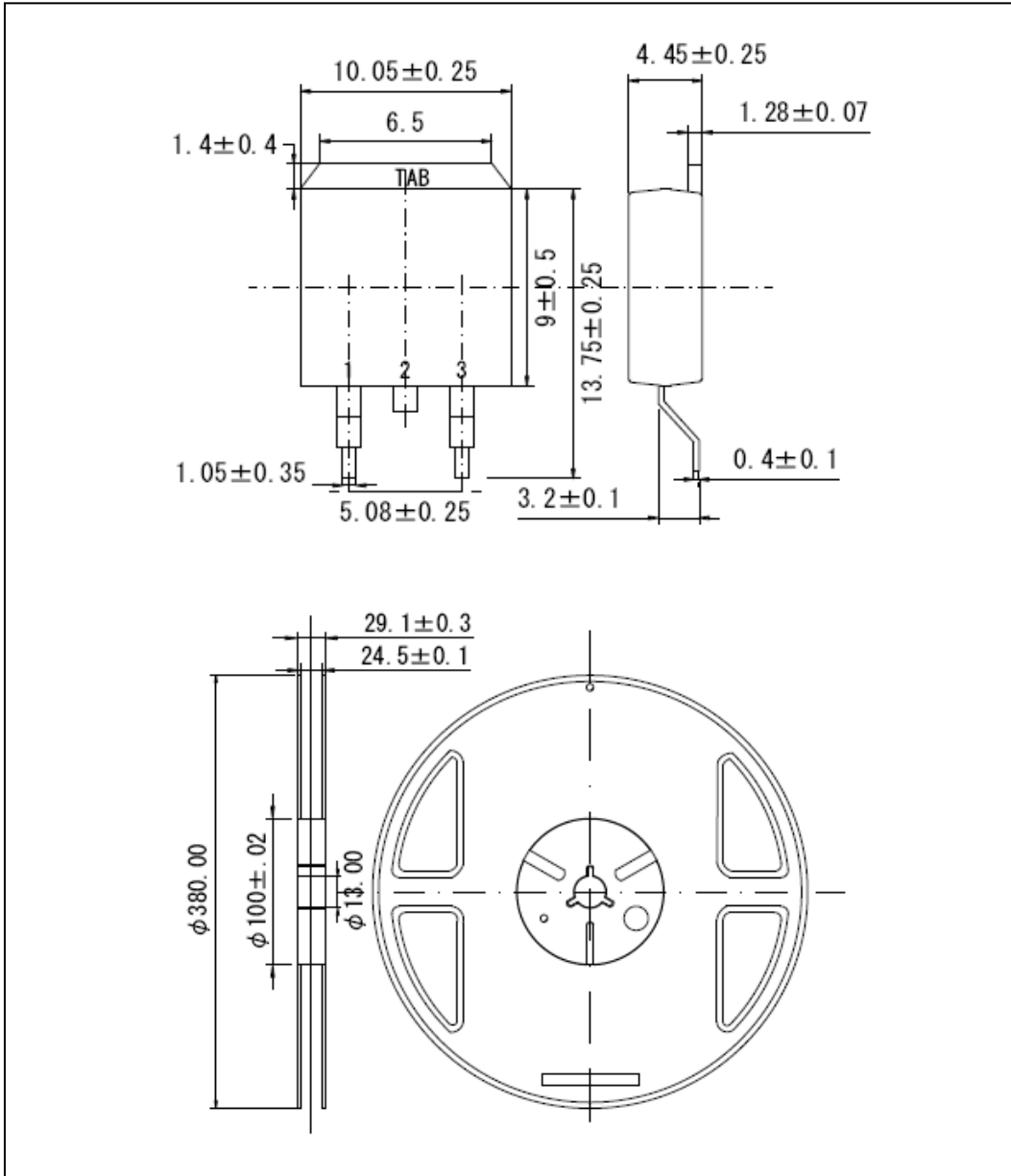

Packing Information

TO-263-3L

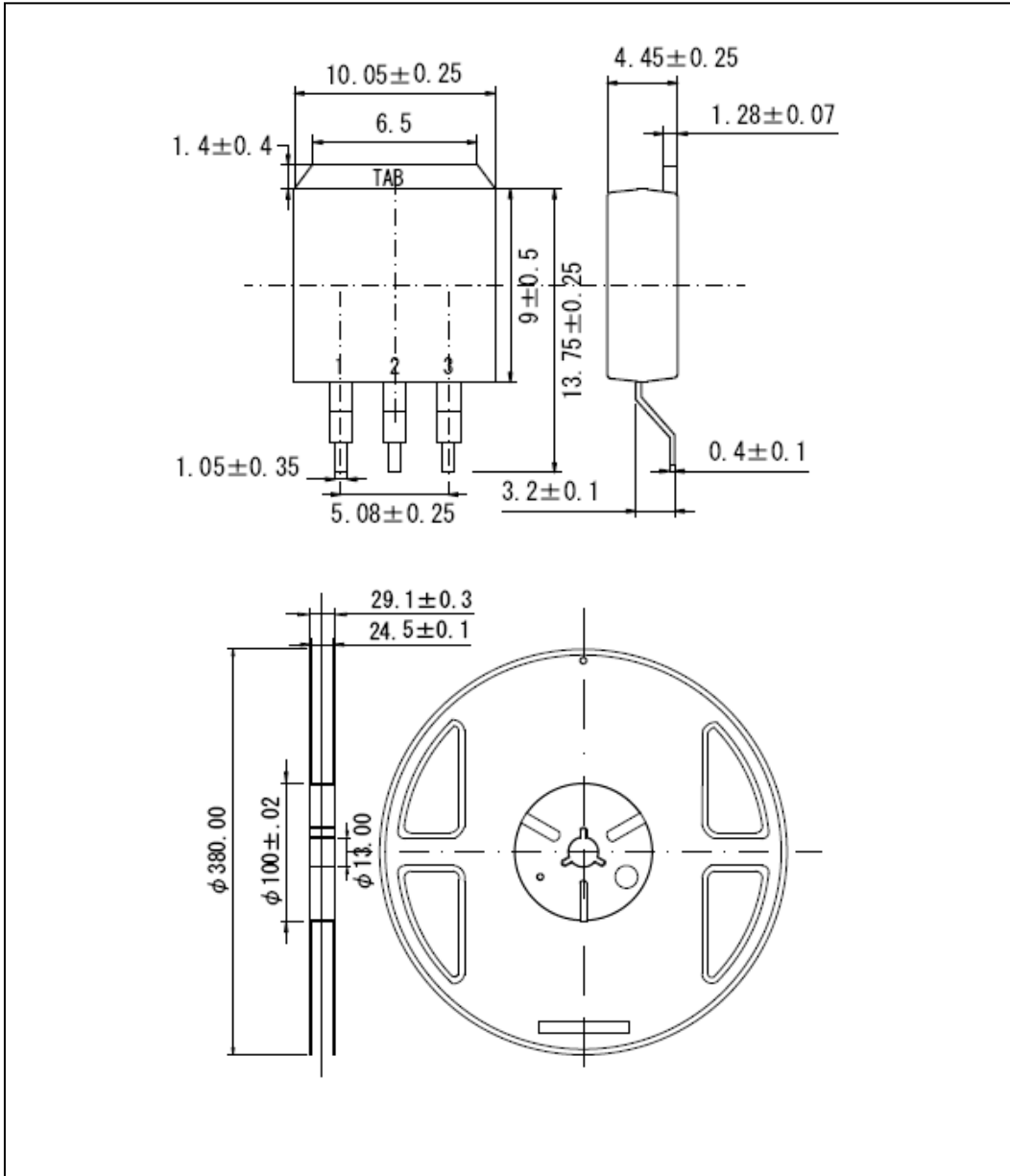

Notes

ACE does not assume any responsibility for use as critical components in life support devices or systems without the express written approval of the president and general counsel of ACE Electronics Co., LTD. As sued herein:

1. Life support devices or systems are devices or systems which, (a) are intended for surgical implant into the body, or (b) support or sustain life, and whose failure to perform when properly used in accordance with instructions for use provided in the labeling, can be reasonably expected to result in a significant injury to the user.
2. A critical component is any component of a life support device or system whose failure to perform can be reasonably expected to cause the failure of the life support device or system, or to affect its safety or effectiveness.

ACE Technology Co., LTD.
<http://www.ace-ele.com/>

This datasheet has been downloaded from:

www.EEworld.com.cn

Free Download

Daily Updated Database

100% Free Datasheet Search Site

100% Free IC Replacement Search Site

Convenient Electronic Dictionary

Fast Search System

www.EEworld.com.cn