



INSTALLATION INSTRUCTIONS

E-SPARK™ BREAKERLESS CONVERSION KIT FOR MALLORY POINT DISTRIBUTORS

NOTE: This product is legal in California only for racing vehicles which may never be operated upon a highway.

IMPORTANT

All kits listed below must be used with an ignition ballast resistor (or loom resistance wire) to prevent module failure. If your vehicle is not equipped with a ballast resistor or loom resistance wire, Mallory Ballast Resistor (Part No. 700) or Mallory Coils 29219, 29450 or 30450 (which are internally ballasted) may be used. *These kits do not work with vacuum advance distributors.*

APPLICATIONS

- Part No. 61004M** Mallory 8 cylinder point distributors (automotive and marine) which use a standard stack cap (Part No. 209 or 209D)
- Part No. 61005M** Mallory 8 cylinder point distributors (automotive and marine) which use a flat cap (Part No. 221 or 221B)
- Part No. 61006M** Mallory 6 cylinder point distributors (automotive and marine) which use a standard stack cap (Part No. 270 or 270B)
- Part No. 61007M** Mallory 6 cylinder point distributors (automotive and marine) which use a mini bowl cap (Part No. 226 or 226B)
- Part No. 61008M** Mallory 4 cylinder point distributors (automotive and marine) which use a standard stack cap (Part No. 271 or 271B)
- Part No. 61009M** Mallory 4 cylinder point distributors (automotive and marine) which use a mini bowl cap (Part No. 225 or 225B)

WARNING

You must install the E-Spark™ Conversion Kit exactly as shown in these instructions. After the kit is installed—and before you start the engine—check all wiring again. Mis-wiring will cause the E-Spark™ Ignition to fail immediately.

INSTALLATION

Step 1

Remove the cap and rotor, then remove the condenser. Remove the plastic insulators (see Figure 1).

Step 2

Loosen the 2 nuts that hold the cap clips/brackets in place (see Figure 1).

NOTE: To loosen the nuts on a marine distributor, the aluminum pins in the brackets may need to be cut in two and removed. Replacement pins are provided.

Step 3

Remove the point plate assembly by lifting it out of the housing (see Figure 1).

PARTS INCLUDE IN THIS KIT:

- 1 E-Spark™ Plate Assembly
- 1 Wire Harness
- 1 Rotor/Shutter Wheel Assembly (PN 559 contains 2 rotor/shutter wheel assemblies)
- 1 Wire Connector
- 1 Grommet, 3-Hole (Marine Approved)
- 2 Pins, Aluminum
- 1 Thrust Button

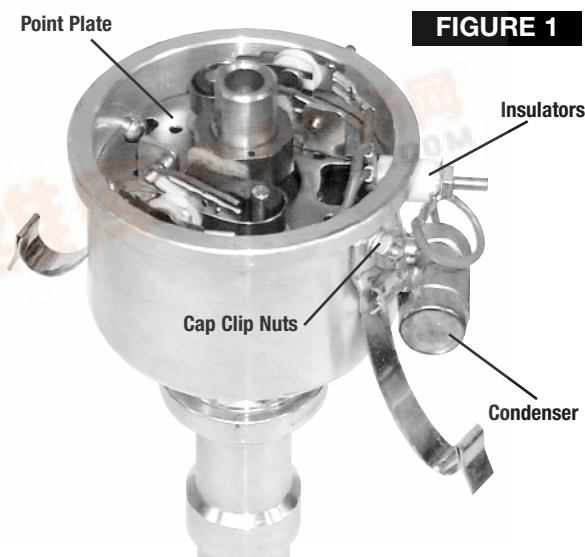

FIGURE 1

Step 4

Use a 2-arm or 3-arm puller and the thrust button (provided) to remove the cam (see Figure 2).

WARNING: Do not try to remove the cam by prying on it with a screwdriver(s). This will damage the advance assembly.

Step 5

Install the E-Spark™ plate assembly into the housing. Make sure that the cut-out in the plate is directly below the hole in the housing where the wires will exit (see Figure 3).

Step 6

Tighten the two nuts that hold the cap clips/brackets in place. This also secures the E-Spark™ plate.

Step 7

Marine Distributors Only

Replace the cap clips using the new aluminum pins provided.

Step 8

Install the wire grommet. Lubricate the wires with light oil. Run the wires through the grommet and out of the distributor housing (see Figure 3).

Step 9

Install the connector onto the wires. Be sure the wires are in the correct positions (see Figure 4).

Step 10

Install the rotor/shutter wheel assembly. Make sure that the rotor is fully seated and that it does not rub the module wires. Replace the cap.

Step 11

If you removed the distributor to install the E-Spark™ Conversion Kit, reinstall the distributor in the engine.

Step 12

Connect the wire harness to the connector. Connect the 3 wires to the correct locations, as shown in Figures 5 and 6.

Step 13

Set the ignition timing. Start the engine and recheck timing.

FIGURE 2

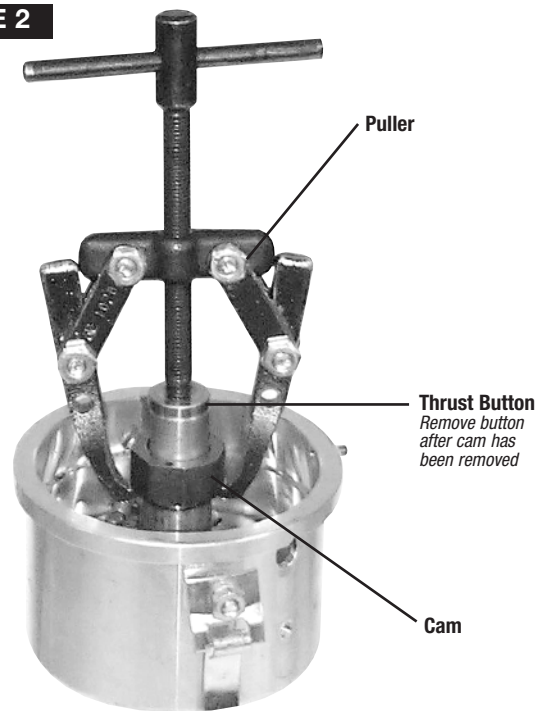

FIGURE 3

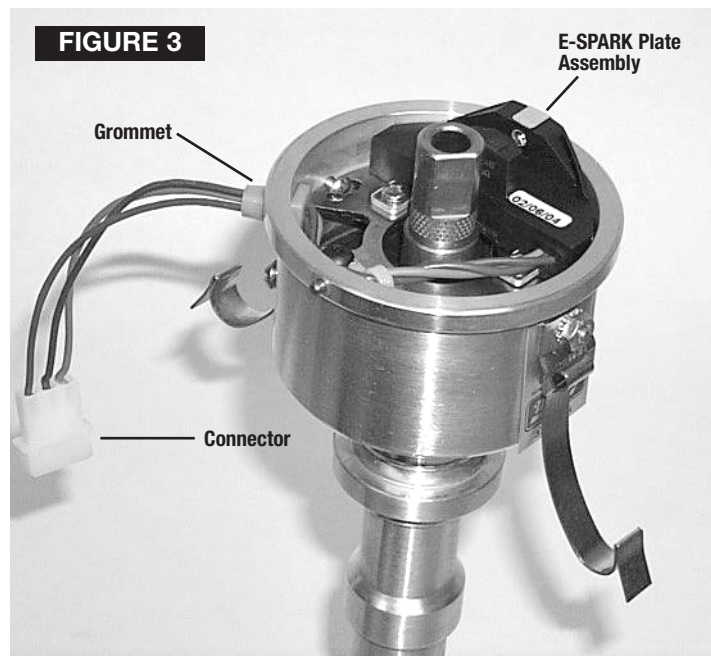

FIGURE 4

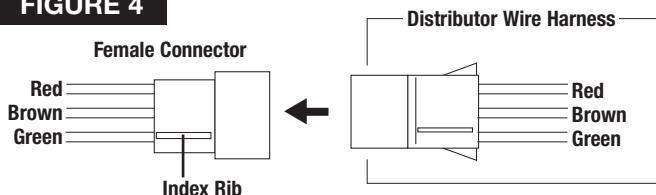

FIGURE 5 EQUIPPED WITH EXTERNAL BALLAST RESISTOR

[查询"61009M"供应商](#)

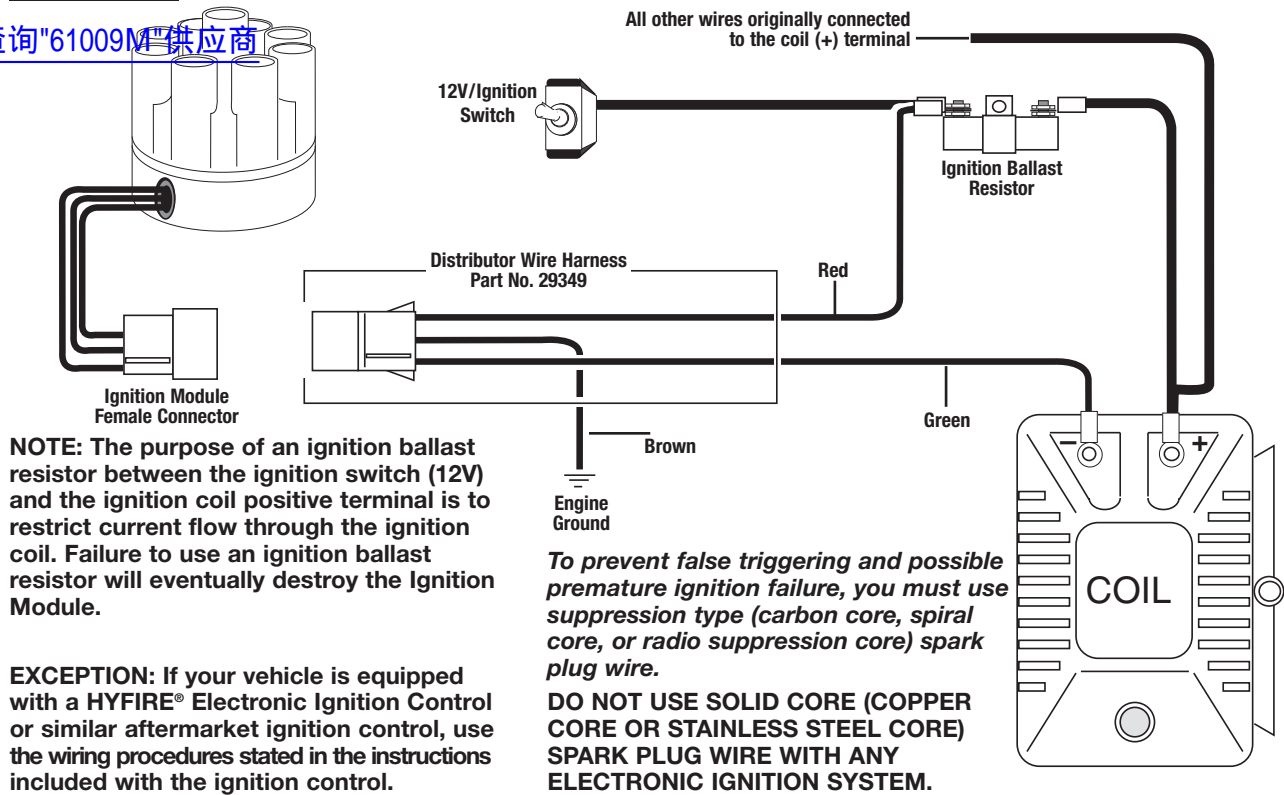

FIGURE 6 EQUIPPED WITH LOOM RESISTANCE WIRE

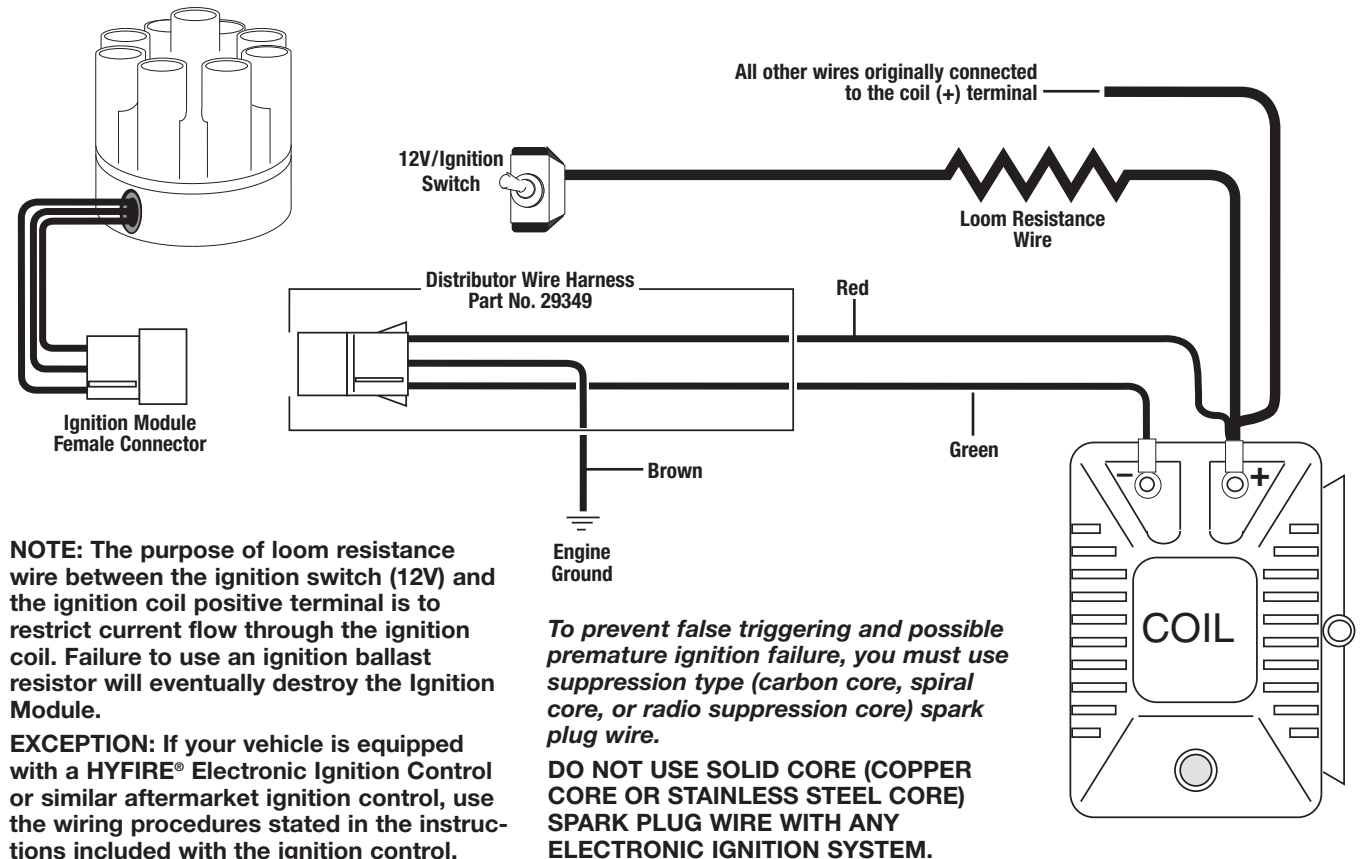

FIGURE 7 EQUIPPED WITH 29219, 29450, OR 30450 COILS ONLY

[查询"61009M"供应商](#)

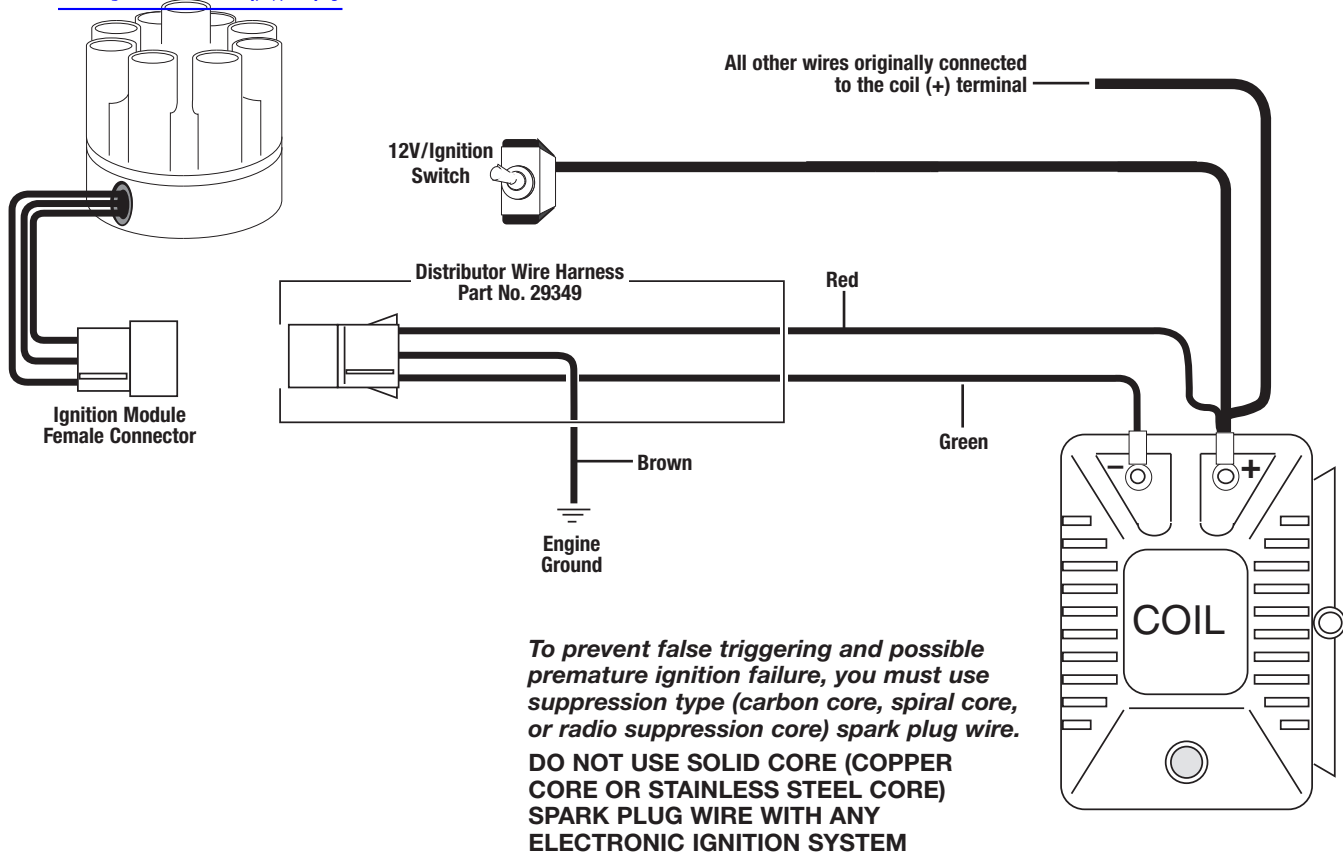
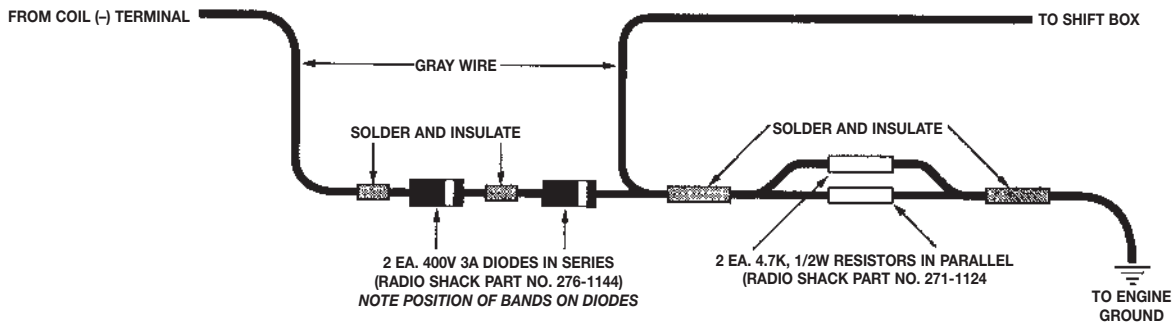

FIGURE 8 FOR MARINE USE ONLY

After installing your Mallory Electronic Distributor, the Electronic Shift Assist (ESA) circuit in your boat must be function tested. Shifting into or out of gear can be difficult or impossible if the ESA circuit is malfunctioning or missing. If you encounter shifter related problems with your boat after installing any Mallory distributor, contact the Mallory Technical Service Department at 216.688.8300.

All Mallory Marine Electronic Ignition Systems in Outboard Marine Corp (OMC) applications with a shift box require the gray wire from the coil to the shift box be modified as follows:

The gray wire from the coil (-) terminal triggers the shift box. The gray wire should be cut or disconnected at the coil terminal so that the components shown here can be inserted. Solder all connections and confirm correct operation, then insulate well, especially if the boat is being used in salt water.



MALLORY IS A DIVISION OF THE MR. GASKET PERFORMANCE GROUP
10601 MEMPHIS AVE. #12, CLEVELAND, OH 44144
216.688.8300 FAX 216.688.8306

FORM 1503
Made in U.S.A.
Printed in U.S.A.