

REVISIONS

LTR	DESCRIPTION	DATE (YR-MO-DA)	APPROVED
查询	5962-9669901 MEA 供应商		

REV																				
SHEET																				
REV																				
SHEET																				

REV STATUS OF SHEETS	REV																			
	SHEET	1	2	3	4	5	6	7	8	9	10	11								

PMIC N/A	PREPARED BY RICK OFFICER	DEFENSE ELECTRONICS SUPPLY CENTER DAYTON, OHIO 45444										
<p><b>STANDARD MICROCIRCUIT DRAWING</b></p> <p>THIS DRAWING IS AVAILABLE FOR USE BY ALL DEPARTMENTS AND AGENCIES OF THE DEPARTMENT OF DEFENSE</p> <p>AMSC N/A</p>	CHECKED BY RAJESH PITHADIA				MICROCIRCUIT, LINEAR, DC MOTOR PULSE WIDTH MODULATOR, MONOLITHIC SILICON							
	APPROVED BY MICHAEL FRYE	<table border="1"> <tr> <td>SIZE</td> <td>CAGE CODE</td> <td rowspan="2"><b>5962-96699</b></td> </tr> <tr> <td><b>A</b></td> <td><b>67268</b></td> </tr> </table>						SIZE	CAGE CODE	<b>5962-96699</b>	<b>A</b>	<b>67268</b>
	SIZE	CAGE CODE	<b>5962-96699</b>									
	<b>A</b>	<b>67268</b>										
DRAWING APPROVAL DATE 96-04-23	SHEET 1 OF 11											
REVISION LEVEL												

1. SCOPE

1.1 ~~Scope~~ ~~Drawing Documents~~ ~~to~~ ~~product~~ ~~assurance~~ ~~class~~ ~~levels~~ ~~consisting~~ ~~of~~ ~~high~~ ~~reliability~~ ~~(device~~ ~~classes~~ ~~Q~~ ~~and~~ ~~M)~~ ~~and~~ ~~space~~ ~~application~~ ~~(device~~ ~~class~~ ~~V)~~. A choice of case outlines and lead finishes are available and are reflected in the Part or Identifying Number (PIN). When available, a choice of Radiation Hardness Assurance (RHA) levels are reflected in the PIN.

1.2 PIN. The PIN is as shown in the following example:

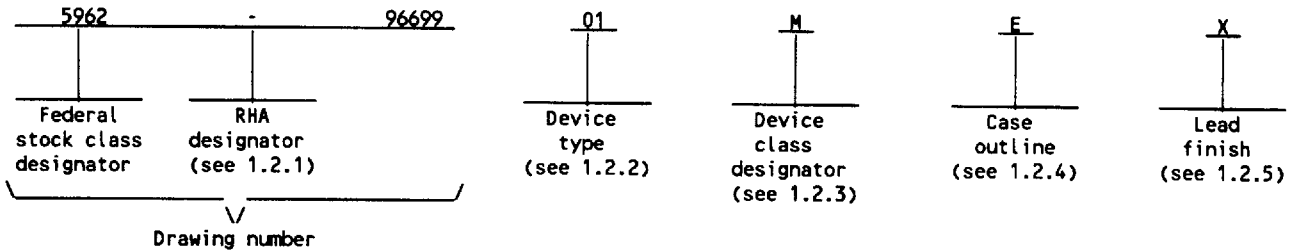

1.2.1 RHA designator. Device classes Q and V RHA marked devices meet the MIL-PRF-38535 specified RHA levels and are marked with the appropriate RHA designator. Device class M RHA marked devices meet the MIL-PRF-38535, appendix A specified RHA levels and are marked with the appropriate RHA designator. A dash (-) indicates a non-RHA device.

1.2.2 Device type(s). The device type(s) identify the circuit function as follows:

<u>Device type</u>	<u>Generic number</u>	<u>Circuit function</u>
01	SG1731	DC motor pulse width modulator

1.2.3 Device class designator. The device class designator is a single letter identifying the product assurance level as follows:

<u>Device class</u>	<u>Device requirements documentation</u>
M	Vendor self-certification to the requirements for MIL-STD-883 compliant, non-JAN class level B microcircuits in accordance with MIL-PRF-38535, appendix A
Q or V	Certification and qualification to MIL-PRF-38535

1.2.4 Case outline(s). The case outline(s) are as designated in MIL-STD-1835 and as follows:

<u>Outline letter</u>	<u>Descriptive designator</u>	<u>Terminals</u>	<u>Package style</u>
E	GDIP1-T16 or CDIP2-T16	16	Dual-in-line

1.2.5 Lead finish. The lead finish is as specified in MIL-PRF-38535 for device classes Q and V or MIL-PRF-38535, appendix A for device class M.

STANDARD MICROCIRCUIT DRAWING DEFENSE ELECTRONICS SUPPLY CENTER DAYTON, OHIO 45444	SIZE <b>A</b>		5962-96699
		REVISION LEVEL	SHEET 2

1.3 Absolute maximum ratings. 1/

查询"5962-9669901MEA"供应商

Supply voltage ( $\pm V_S$ )	$\pm 18$ V
Analog inputs	$\pm V_S$
Output driver supply voltage ( $\pm V_O$ )	$\pm 25$ V
Digital inputs (SHUTDOWN)	$-V_S - 0.3$ V to $-V_S + 18$ V
Source/sink output current (continuous)	200 mA
Source/sink output current (peak, 500 ns)	400 mA
Output driver diode current (continuous)	200 mA
Output driver diode current (peak, 500 ns)	400 mA
Power dissipation ( $P_D$ )	1560 mW
Junction temperature ( $T_J$ )	+150°C
Storage temperature range	-65°C to +150°C
Lead temperature (soldering, 10 seconds)	+300°C
Thermal resistance, junction-to-case ( $\theta_{JC}$ )	See MIL-STD-1835
Thermal resistance, junction-to-ambient ( $\theta_{JA}$ )	80°C/W

1.4 Recommended operating conditions.

Supply voltage range ( $\pm V_S$ )	$\pm 3.5$ V to $\pm 15$ V
Error amp common-mode range	$-V_S + 3$ V to $-V_S - 3$ V
Output driver supply voltage range	$\pm 2.5$ V to $\pm 22$ V
Source/sink output current (continuous)	100 mA
Source/sink output current (peak, 500 ns)	200 mA
Output driver diode current (continuous)	100 mA
Output driver diode current (peak, 500 ns)	200 mA
Oscillator frequency range	10 Hz to 350 kHz
Oscillator voltage (peak-to-peak)	1 V to 10 V
Oscillator timing capacitor ( $C_T$ )	200 pF to 2.5 $\mu$ F
Ambient operating temperature range ( $T_A$ )	-55°C to +125°C

2. APPLICABLE DOCUMENTS

2.1 Government specification, standards, and handbooks. The following specification, standards, and handbooks form a part of this drawing to the extent specified herein. Unless otherwise specified, the issues of these documents are those listed in the issue of the Department of Defense Index of Specifications and Standards (DoDISS) and supplement thereto, cited in the solicitation.

SPECIFICATION

MILITARY

MIL-PRF-38535 - Integrated Circuits, Manufacturing, General Specification for.

STANDARDS

MILITARY

MIL-STD-883 - Test Methods and Procedures for Microelectronics.  
 MIL-STD-973 - Configuration Management.  
 MIL-STD-1835 - Microcircuit Case Outlines.

1/ Stresses above the absolute maximum rating may cause permanent damage to the device. Extended operation at the maximum levels may degrade performance and affect reliability.

STANDARD MICROCIRCUIT DRAWING DEFENSE ELECTRONICS SUPPLY CENTER DAYTON, OHIO 45444	SIZE <b>A</b>		<b>5962-96699</b>
		REVISION LEVEL	SHEET <b>3</b>

MILITARY

- MIL-HDBK-103 - List of Standard Microcircuit Drawings (SMD's).
- MIL-HDBK-780 - Standard Microcircuit Drawings.

(Unless otherwise indicated, copies of the specification, standards, and handbooks are available from the Standardization Document Order Desk, 700 Robbins Avenue, Building 4D, Philadelphia, PA 19111-5094.)

2.2 Order of precedence. In the event of a conflict between the text of this drawing and the references cited herein, the text of this drawing takes precedence. Nothing in this document, however, supersedes applicable laws and regulations unless a specific exemption has been obtained.

3. REQUIREMENTS

3.1 Item requirements. The individual item requirements for device classes Q and V shall be in accordance with MIL-PRF-38535 and as specified herein or as modified in the device manufacturer's Quality Management (QM) plan. The modification in the QM plan shall not affect the form, fit, or function as described herein. The individual item requirements for device class M shall be in accordance with MIL-PRF-38535, appendix A for non-JAN class level B devices and as specified herein.

3.2 Design, construction, and physical dimensions. The design, construction, and physical dimensions shall be as specified in MIL-PRF-38535 and herein for device classes Q and V or MIL-PRF-38535, appendix A and herein for device class M.

3.2.1 Case outline(s). The case outline(s) shall be in accordance with 1.2.4 herein.

3.2.2 Terminal connections. The terminal connections shall be as specified on figure 1.

3.2.3 Logic diagram(s). The logic diagram(s) shall be as specified on figure 2.

3.3 Electrical performance characteristics and postirradiation parameter limits. Unless otherwise specified herein, the electrical performance characteristics and postirradiation parameter limits are as specified in table I and shall apply over the full ambient operating temperature range.

3.4 Electrical test requirements. The electrical test requirements shall be the subgroups specified in table II. The electrical tests for each subgroup are defined in table I.

3.5 Marking. The part shall be marked with the PIN listed in 1.2 herein. In addition, the manufacturer's PIN may also be marked as listed in MIL-HDBK-103. For packages where marking of the entire SMD PIN number is not feasible due to space limitations, the manufacturer has the option of not marking the "5962-" on the device. For RHA product using this option, the RHA designator shall still be marked. Marking for device classes Q and V shall be in accordance with MIL-PRF-38535. Marking for device class M shall be in accordance with MIL-PRF-38535, appendix A.

3.5.1 Certification/compliance mark. The certification mark for device classes Q and V shall be a "QML" or "Q" as required in MIL-PRF-38535. The compliance mark for device class M shall be a "C" as required in MIL-PRF-38535, appendix A.

3.6 Certificate of compliance. For device classes Q and V, a certificate of compliance shall be required from a QML-38535 listed manufacturer in order to supply to the requirements of this drawing (see 6.6.1 herein). For device class M, a certificate of compliance shall be required from a manufacturer in order to be listed as an approved source of supply in MIL-HDBK-103 (see 6.6.2 herein). The certificate of compliance submitted to DESC-EC prior to listing as an approved source of supply for this drawing shall affirm that the manufacturer's product meets, for device classes Q and V, the requirements of MIL-PRF-38535 and herein or for device class M, the requirements of MIL-PRF-38535, appendix A and herein.

3.7 Certificate of conformance. A certificate of conformance as required for device classes Q and V in MIL-PRF-38535 or for device class M in MIL-PRF-38535, appendix A shall be provided with each lot of microcircuits delivered to this drawing.

3.8 Notification of change for device class M. For device class M, notification to DESC-EC of change of product (see 6.2 herein) involving devices acquired to this drawing is required for any change as defined in MIL-STD-973.

STANDARD MICROCIRCUIT DRAWING DEFENSE ELECTRONICS SUPPLY CENTER DAYTON, OHIO 45444	SIZE <b>A</b>		5962-96699
		REVISION LEVEL	SHEET 4

TABLE I. Electrical performance characteristics.

查询"5962-9669901MEA"供应商

Test	Symbol	Conditions 1/ -55°C ≤ T <sub>A</sub> ≤ +125°C unless otherwise specified	Group A subgroups	Device Type	Limits		Unit
					Min	Max	
Oscillator section							
Timing capacitor charging current	I <sub>CT</sub>		1, 2, 3	01	400	600	μA
2 VΔ± input bias current	I <sub>IB</sub>	V <sub>CM</sub> = ±5 V	1, 2, 3	01		20	μA
Initial oscillator frequency	f <sub>IO</sub>	C <sub>T</sub> = 1000 pF, T <sub>A</sub> = +25°C, 2 VΔ± = ±5 V	4	01	22.5	27.5	kHz
Temperature stability	t <sub>S</sub>	C <sub>T</sub> = 1000 pF, 2/ 2 VΔ± = ±5 V	1, 2, 3	01		10	%
Error amplifier section 3/							
Input offset voltage	V <sub>IO</sub>		1, 2, 3	01		10	mV
Input bias current	I <sub>IB</sub>		1, 2, 3	01		3	μA
Input offset current	I <sub>OS</sub>		1, 2, 3	01		600	nA
Open loop voltage gain	A <sub>VOL</sub>	R <sub>L</sub> = 2 kΩ	4, 5, 6	01	70		dB
Output voltage swing	V <sub>SW</sub>	R <sub>L</sub> = 2 kΩ	1, 2, 3	01	10		V
Common mode rejection ratio	CMRR		4, 5, 6	01	70		dB
Slew rate 2/	SR	Measured at 10% and 90% points, T <sub>A</sub> = +25°C	4	01	5		V/μs
Unity gain bandwidth	UGBW	T <sub>A</sub> = +25°C 2/ 4/	4, 5, 6	01	0.7		MHz
Pulse width modulator comparators section							
Input bias current	I <sub>IB</sub>	±V <sub>T</sub> = ±3 V	1, 2, 3	01		6	μA
SHUTDOWN section							
Logic threshold voltage	V <sub>LT</sub>	V <sub>S</sub> = -3.5 V to -15 V	1, 2, 3	01	V <sub>S</sub> to +0.8	V <sub>S</sub> to +2.0 V	V
SHUTDOWN high current	I <sub>HSD</sub>	V <sub>SD</sub> = -V <sub>S</sub> + 2.4 V	1, 2, 3	01		400	μA
SHUTDOWN low current	I <sub>LSD</sub>	V <sub>SD</sub> = -V <sub>S</sub>	1, 2, 3	01		-1	mA

See footnotes at end of table.

STANDARD  
MICROCIRCUIT DRAWING  
DEFENSE ELECTRONICS SUPPLY CENTER  
DAYTON, OHIO 45444

SIZE  
A

5962-96699

REVISION LEVEL

SHEET

5

TABLE I. Electrical performance characteristics - Continued.

查询"5962-9669901MFE"供应商

Test	Symbol	Conditions 1/ -55°C ≤ T <sub>A</sub> ≤ +125°C unless otherwise specified	Group A subgroups	Device Type	Limits		Unit
					Min	Max	
Output drivers (each output) section							
High output voltage	V <sub>OH</sub>	I <sub>SOURCE</sub> = 20 mA	1	01	19.2		V
		I <sub>SOURCE</sub> = 100 mA	2, 3		19.0		
Low output voltage	V <sub>OL</sub>	I <sub>SOURCE</sub> = 20 mA	1	01		-19.2	V
		I <sub>SOURCE</sub> = 100 mA	2, 3			-19.0	
Driver rise time	t <sub>R</sub>	C <sub>L</sub> = 1000 pF	9, 10, 11	01		300	ns
Driver fall time	t <sub>F</sub>	C <sub>L</sub> = 1000 pF	9, 10, 11	01		300	ns
Total supply current section							
Supply current	I <sub>S</sub>	V <sub>SD</sub> = -V <sub>S</sub> + 0.8 V	1, 2, 3	01		14	mA
Output supply current	I <sub>OS</sub>	V <sub>SD</sub> = -V <sub>S</sub> + 0.8 V	1, 2, 3	01		60	mA

- 1/ Supply voltage (V<sub>S</sub>) = ±15 V and output voltage (V<sub>O</sub>) = ±22 V.
- 2/ If not tested, shall be guaranteed to the limits specified in table I herein.
- 3/ Common mode voltage (V<sub>CM</sub>) = ±12 V.
- 4/ Unity gain inverting 10 kΩ feedback resistance.

3.9 Verification and review for device class M. For device class M, DESC, DESC's agent, and the acquiring activity retain the option to review the manufacturer's facility and applicable required documentation. Offshore documentation shall be made available onshore at the option of the reviewer.

3.10 Microcircuit group assignment for device class M. Device class M devices covered by this drawing shall be in microcircuit group number 58 (see MIL-PRF-38535, appendix A).

4. QUALITY ASSURANCE PROVISIONS

4.1 Sampling and inspection. For device classes Q and V, sampling and inspection procedures shall be in accordance with MIL-PRF-38535 or as modified in the device manufacturer's Quality Management (QM) plan. The modification in the QM plan shall not affect the form, fit, or function as described herein. For device class M, sampling and inspection procedures shall be in accordance with MIL-PRF-38535, appendix A.

4.2 Screening. For device classes Q and V, screening shall be in accordance with MIL-PRF-38535, and shall be conducted on all devices prior to qualification and technology conformance inspection. For device class M, screening shall be in accordance with method 5004 of MIL-STD-883, and shall be conducted on all devices prior to quality conformance inspection.

4.2.1 Additional criteria for device class M.

a. Burn-in test, method 1015 of MIL-STD-883.

(1) Test condition A, B, C, or D. The test circuit shall be maintained by the manufacturer under document revision level control and shall be made available to the preparing or acquiring activity upon request. The test circuit shall specify the inputs, outputs, biases, and power dissipation, as applicable, in accordance with the intent specified in test method 1015.

(2) T<sub>A</sub> = +125°C, minimum.

b. Interim and final electrical test parameters shall be as specified in table II herein.

STANDARD MICROCIRCUIT DRAWING DEFENSE ELECTRONICS SUPPLY CENTER DAYTON, OHIO 45444	SIZE <b>A</b>		5962-96699
		REVISION LEVEL	SHEET 6

Device type	All	
Case outlines	E	2
Terminal number	Terminal symbol	
1	+V <sub>T</sub>	NC
2	2 V <sub>Δ+</sub>	+V <sub>T</sub>
3	NONINVERTED INPUT	2 V <sub>Δ+</sub>
4	INVERTED INPUT	NONINVERTED INPUT
5	ERROR	INVERTED INPUT
6	C <sub>T</sub>	NC
7	2 V <sub>Δ-</sub>	ERROR
8	-V <sub>T</sub>	C <sub>T</sub>
9	-V <sub>S</sub>	2 V <sub>Δ-</sub>
10	SUBSTRATE	-V <sub>T</sub>
11	-V <sub>O</sub>	NC
12	OUTPUT B	-V <sub>S</sub>
13	OUTPUT A	SUBSTRATE
14	+V <sub>O</sub>	-V <sub>O</sub>
15	SHUTDOWN	OUTPUT B
16	+V <sub>S</sub>	NC
17	---	OUTPUT A
18	---	+V <sub>O</sub>
19	---	SHUTDOWN
20	---	+V <sub>S</sub>

FIGURE 1. Terminal connections.

STANDARD MICROCIRCUIT DRAWING DEFENSE ELECTRONICS SUPPLY CENTER DAYTON, OHIO 45444	SIZE <b>A</b>		5962-96699
		REVISION LEVEL	SHEET 7

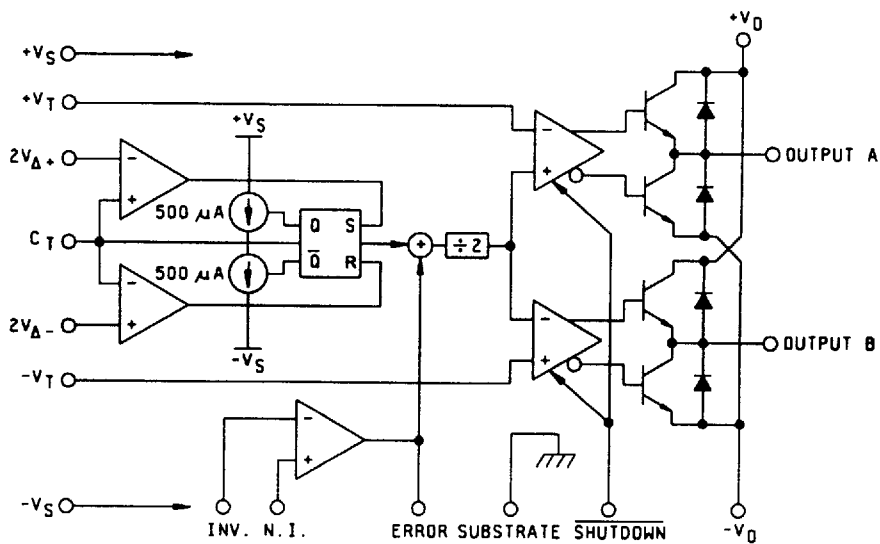

FIGURE 2. Logic diagram.

STANDARD MICROCIRCUIT DRAWING DEFENSE ELECTRONICS SUPPLY CENTER DAYTON, OHIO 45444	SIZE <b>A</b>		5962-96699
		REVISION LEVEL	SHEET 8



4.2.2 Additional criteria for device classes Q and V.

查询"5962-966901MEA"供应商

- a. The burn-in test duration, test condition and test temperature, or approved alternatives shall be as specified in the device manufacturer's QM plan in accordance with MIL-PRF-38535. The burn-in test circuit shall be maintained under document revision level control of the device manufacturer's Technology Review Board (TRB) in accordance with MIL-PRF-38535 and shall be made available to the acquiring or preparing activity upon request. The test circuit shall specify the inputs, outputs, biases, and power dissipation, as applicable, in accordance with the intent specified in test method 1015 of MIL-STD-883.
- b. Interim and final electrical test parameters shall be as specified in table II herein.
- c. Additional screening for device class V beyond the requirements of device class Q shall be as specified in MIL-PRF-38535, appendix B.

4.3 Qualification inspection for device classes Q and V. Qualification inspection for device classes Q and V shall be in accordance with MIL-PRF-38535. Inspections to be performed shall be those specified in MIL-PRF-38535 and herein for groups A, B, C, D, and E inspections (see 4.4.1 through 4.4.4).

4.4 Conformance inspection. Technology conformance inspection for classes Q and V shall be in accordance with MIL-PRF-38535 including groups A, B, C, D, and E inspections and as specified herein except where option 2 of MIL-PRF-38535 permits alternate in-line control testing. Quality conformance inspection for device class M shall be in accordance with MIL-PRF-38535, appendix A and as specified herein. Inspections to be performed for device class M shall be those specified in method 5005 of MIL-STD-883 and herein for groups A, B, C, D, and E inspections (see 4.4.1 through 4.4.4).

4.4.1 Group A inspection.

- a. Tests shall be as specified in table II herein.
- b. Subgroups 7 and 8 in table I, method 5005 of MIL-STD-883 shall be omitted.

4.4.2 Group C inspection. The group C inspection end-point electrical parameters shall be as specified in table II herein.

4.4.2.1 Additional criteria for device class M. Steady-state life test conditions, method 1005 of MIL-STD-883:

- a. Test condition A, B, C, or D. The test circuit shall be maintained by the manufacturer under document revision level control and shall be made available to the preparing or acquiring activity upon request. The test circuit shall specify the inputs, outputs, biases, and power dissipation, as applicable, in accordance with the intent specified in test method 1005 of MIL-STD-883.
- b.  $T_A = +125^\circ\text{C}$ , minimum.
- c. Test duration: 1,000 hours, except as permitted by method 1005 of MIL-STD-883.

4.4.2.2 Additional criteria for device classes Q and V. The steady-state life test duration, test condition and test temperature, or approved alternatives shall be as specified in the device manufacturer's QM plan in accordance with MIL-PRF-38535. The test circuit shall be maintained under document revision level control by the device manufacturer's TRB in accordance with MIL-PRF-38535 and shall be made available to the acquiring or preparing activity upon request. The test circuit shall specify the inputs, outputs, biases, and power dissipation, as applicable, in accordance with the intent specified in test method 1005 of MIL-STD-883.

4.4.3 Group D inspection. The group D inspection end-point electrical parameters shall be as specified in table II herein.

STANDARD MICROCIRCUIT DRAWING DEFENSE ELECTRONICS SUPPLY CENTER DAYTON, OHIO 45444	SIZE A		5962-96699
		REVISION LEVEL	SHEET 9

TABLE II. Electrical test requirements.

查询"5962-9669901MFA"供应商

Test requirements	Subgroups (in accordance with MIL-STD-883, method 5005, table I)	Subgroups (in accordance with MIL-PRF-38535, table III)	
	Device class M	Device class Q	Device class V
Interim electrical parameters (see 4.2)	---	---	---
Final electrical parameters (see 4.2)	1,2,3,4,5, 1/ 6,9,10,11	1,2,3,4, 1/ 5,6,9,10,11	1,2,3,4, 1/ 5,6,9,10,11
Group A test requirements (see 4.4)	1,2,3,4,5,6,9, 10,11	1,2,3,4,5, 6,9,10,11	1,2,3,4,5, 6,9,10,11
Group C end-point electrical parameters (see 4.4)	1	1	1,2,3
Group D end-point electrical parameters (see 4.4)	1	1	1
Group E end-point electrical parameters (see 4.4)	---	---	---

1/ PDA applies to subgroup 1.

4.4.4 Group E inspection. Group E inspection is required only for parts intended to be marked as radiation hardness assured (see 3.5 herein).

- a. End-point electrical parameters shall be as specified in table II herein.
- b. For device classes Q and V, the devices or test vehicle shall be subjected to radiation hardness assured tests as specified in MIL-PRF-38535 for the RHA level being tested. For device class M, the devices shall be subjected to radiation hardness assured tests as specified in MIL-PRF-38535, appendix A for the RHA level being tested. All device classes must meet the postirradiation end-point electrical parameter limits as defined in table I at  $T_A = +25^\circ\text{C} \pm 5^\circ\text{C}$ , after exposure, to the subgroups specified in table II herein.
- c. When specified in the purchase order or contract, a copy of the RHA delta limits shall be supplied.

5. PACKAGING

5.1 Packaging requirements. The requirements for packaging shall be in accordance with MIL-PRF-38535 for device classes Q and V or MIL-PRF-38535, appendix A for device class M.

6. NOTES

6.1 Intended use. Microcircuits conforming to this drawing are intended for use for Government microcircuit applications (original equipment), design applications, and logistics purposes.

6.1.1 Replaceability. Microcircuits covered by this drawing will replace the same generic device covered by a contractor-prepared specification or drawing.

6.1.2 Substitutability. Device class Q devices will replace device class M devices.

6.2 Configuration control of SMD's. All proposed changes to existing SMD's will be coordinated with the users of record for the individual documents. This coordination will be accomplished in accordance with MIL-STD-973 using DD Form 1692, Engineering Change Proposal.

STANDARD MICROCIRCUIT DRAWING DEFENSE ELECTRONICS SUPPLY CENTER DAYTON, OHIO 45444	SIZE <b>A</b>		5962-96699
		REVISION LEVEL	SHEET 10

6.3 Record of users. Military and industrial users should inform Defense Electronics Supply Center when a system application requires design information control and which SMD's are applicable to that system. DESC will maintain a record of users and this list will be used for coordination and distribution of changes to the drawings. Users of drawings covering microelectronic devices (FSC 5962) should contact DESC-EC, telephone (513) 296-6047.

6.4 Comments. Comments on this drawing should be directed to DESC-EC, Dayton, Ohio 45444-5270, or telephone (513) 296-5377.

6.5 Abbreviations, symbols, and definitions. The abbreviations, symbols, and definitions used herein are defined in MIL-PRF-38535 and MIL-HDBK-1331.

6.6 Sources of supply.

6.6.1 Sources of supply for device classes Q and V. Sources of supply for device classes Q and V are listed in QML-38535. The vendors listed in QML-38535 have submitted a certificate of compliance (see 3.6 herein) to DESC-EC and have agreed to this drawing.

6.6.2 Approved sources of supply for device class M. Approved sources of supply for class M are listed in MIL-HDBK-103. The vendors listed in MIL-HDBK-103 have agreed to this drawing and a certificate of compliance (see 3.6 herein) has been submitted to and accepted by DESC-EC.

<b>STANDARD MICROCIRCUIT DRAWING DEFENSE ELECTRONICS SUPPLY CENTER DAYTON, OHIO 45444</b>	<b>SIZE A</b>		<b>5962-96699</b>
		<b>REVISION LEVEL</b>	<b>SHEET 11</b>