

DRAWING MADE IN THIRD ANGLE PROJECTION

THIS DRAWING IS UNPUBLISHED. RELEASED FOR PUBLICATION 19  
 © COPYRIGHT 19 BY AMP INCORPORATED, HARRISBURG, PA. ALL INTERNATIONAL RIGHTS RESERVED. AMP PRODUCTS MAY BE COVERED BY U.S. AND FOREIGN PATENTS AND/OR PATENTS PENDING.

MOD 3 LOC BD DIST 16

| REVISIONS |   |      |     |                    |            |          |
|-----------|---|------|-----|--------------------|------------|----------|
| P         | F | ZONE | LTR | DESCRIPTION        | DATE       | APPROVED |
| 0         | ✓ |      |     | REL.               |            |          |
| A         | ✓ |      |     | REV. PER ECN 0094  | JP 6/15/84 | WSP      |
| A         | ✓ |      |     | REV. PER ECN-0509  | WE 2/26/84 |          |
| B         | ✓ |      |     | OBS - 5 ECN BD5014 | 5-20-84    | WIK      |

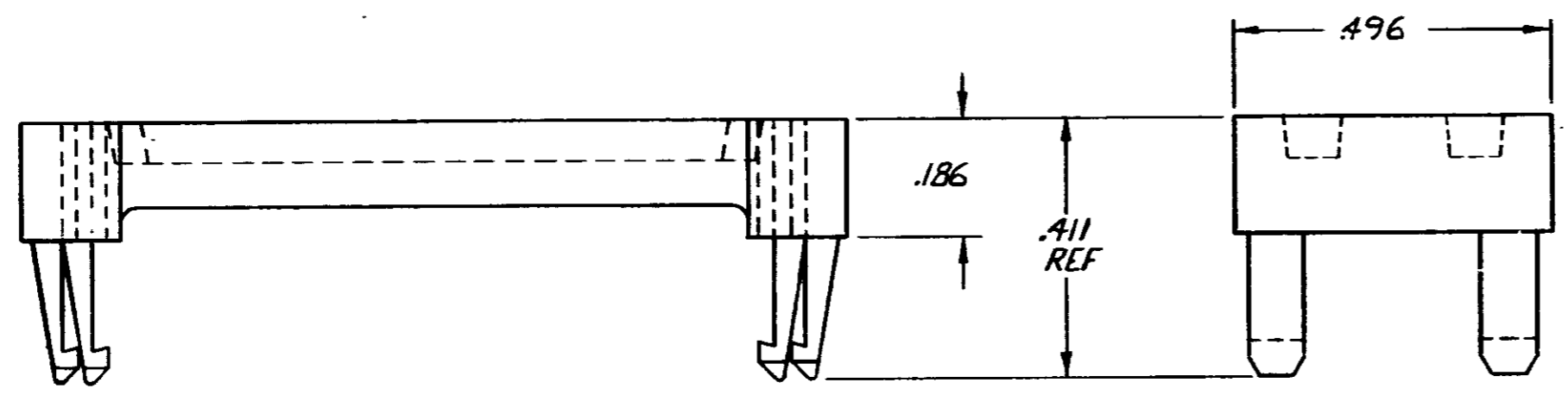
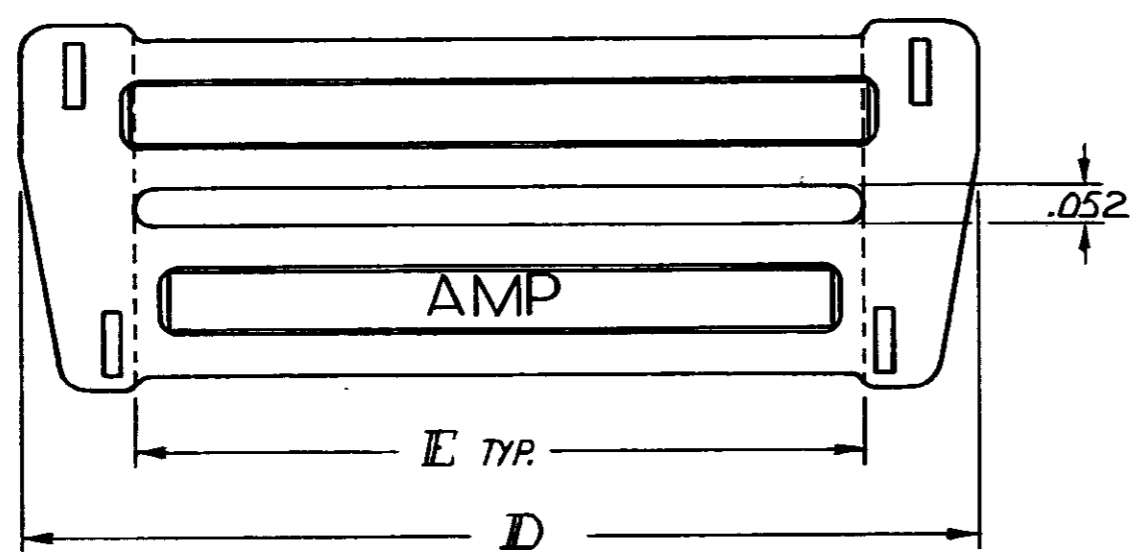

| OBSOLETE | .980  | 1.287 | 19          | 747275-5 |
|----------|-------|-------|-------------|----------|
|          | 1.880 | 2.275 | 37          | -1       |
|          | 1.280 | 1.623 | 25          | -2       |
|          | .780  | 1.087 | 15          | -3       |
|          | .480  | .759  | 9           | 747275-4 |
|          | E     | D     | NO. OF POS. | PART NO  |

|  |                                      |  |                         |                             |
|--|--------------------------------------|--|-------------------------|-----------------------------|
| UNLESS OTHERWISE SPECIFIED DIMENSIONS ARE IN INCHES.<br>TOLERANCES ON:<br>DECIMALS ±.005<br>ANGLES ± | CONTRACT NO                          | <b>AMP</b>   AMP INCORPORATED<br>Harrisburg, Pa. 17105 |                         |                             |
|  | DR<br><i>J. C. Zilko</i> 8/25/83     |  |                         | NAME                        |
| MATERIAL<br>FLAME RETARDANT<br>THERMOPLASTIC; COLOR:<br>BLACK 94V-0 RATED                            | CHK'D<br><i>J. S. ...</i> 8-25-83    | STRAIN RELIEF, LOW PROFILE HDF                         |                         |                             |
| FINISH   | APPROV'D<br><i>J. J. ...</i> 8-25-83 |  |                         |                             |
|  | APPD<br><i>J. J. ...</i> 7-29-83     | SIZE<br><b>C</b>                                       | FSCM NO<br><b>00779</b> | DRAWING NO<br><b>747275</b> |
|  | DSGN APPD                            | SCALE  | SHEET                   |                             |
|  | OTHER APPD                           |  |                         |                             |

747275