

FAIRCHILD
SEMICONDUCTOR™

August 1986
Revised March 2000

DM74LS283 4-Bit Binary Adder with Fast Carry

General Description

These full adders perform the addition of two 4-bit binary numbers. The sum (Σ) outputs are provided for each bit and the resultant carry (C4) is obtained from the fourth bit. These adders feature full internal look ahead across all four bits. This provides the system designer with partial look-ahead performance at the economy and reduced package count of a ripple-carry implementation.

The adder logic, including the carry, is implemented in its true form meaning that the end-around carry can be accomplished without the need for logic or level inversion.

Features

- Full-carry look-ahead across the four bits
- Systems achieve partial look-ahead performance with the economy of ripple carry
- Typical add times
 - Two 8-bit words 25 ns
 - Two 16-bit words 45 ns
- Typical power dissipation per 4-bit adder 95 mW

Ordering Code:

Order Number	Package Number	Package Description
DM74LS283M	M16A	16-Lead Small Outline Integrated Circuit (SOIC), JEDEC MS-012, 0.150 Narrow
DM74LS283N	N16E	16-Lead Plastic Dual-In-Line Package (PDIP), JEDEC MS-001, 0.300 Wide

Devices also available in Tape and Reel. Specify by appending the suffix letter "X" to the ordering code.

Connection Diagram

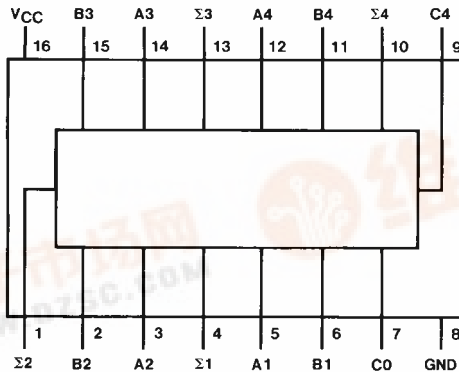

DM74LS283 4-Bit Binary Adder with Fast Carry



Absolute Maximum Ratings (Note 1)

Supply Voltage	7V
Input Voltage	7V
Operating Free Air Temperature Range	0°C to +70°C
Storage Temperature Range	-65°C to +150°C

Note 1: The "Absolute Maximum Ratings" are those values beyond which the safety of the device cannot be guaranteed. The device should not be operated at these limits. The parametric values defined in the Electrical Characteristics tables are not guaranteed at the absolute maximum ratings. The "Recommended Operating Conditions" table will define the conditions for actual device operation.

Recommended Operating Conditions

Symbol	Parameter	Min	Nom	Max	Units
V _{CC}	Supply Voltage	4.75	5	5.25	V
V _{IH}	HIGH Level Input Voltage	2			V
V _{IL}	LOW Level Input Voltage			0.8	V
I _{OH}	HIGH Level Output Current			-0.4	mA
I _{OL}	LOW Level Output Current			8	mA
T _A	Free Air Operating Temperature	0		70	°C

Electrical Characteristics

over recommended operating free air temperature range (unless otherwise noted)

Symbol	Parameter	Conditions	Min	Typ (Note 2)	Max	Units
V _I	Input Clamp Voltage	V _{CC} = Min, I _I = -18 mA			-1.5	V
V _{OH}	HIGH Level Output Voltage	V _{CC} = Min, I _{OH} = Max V _{IL} = Max, V _{IH} = Min	2.7	3.4		V
V _{OL}	LOW Level Output Voltage	V _{CC} = Min, I _{OL} = Max V _{IL} = Max, V _{IH} = Min I _{OL} = 4 mA, V _{CC} = Min		0.35 0.25	0.5 0.4	V
I _I	Input Current @ Max Input Voltage	V _{CC} = Max V _I = 7V	A, B C0		0.2 0.1	mA
I _{IH}	HIGH Level Input Current	V _{CC} = Max V _I = 2.7V	A, B C0		40 20	μA
I _{IL}	LOW Level Input Current	V _{CC} = Max V _I = 0.4V	A, B C0		-0.8 -0.4	mA
I _{OS}	Short Circuit Output Current	V _{CC} = Max		-20	-100	mA
I _{CC1}	Supply Current	V _{CC} = Max (Note 4)		19	34	mA
I _{CC2}	Supply Current	V _{CC} = Max (Note 5)		22	39	mA

Note 2: All typicals are at V_{CC} = 5V, T_A = 25°C.

Note 3: Not more than one output should be shorted at a time, and the duration should not exceed one second.

Note 4: I_{CC1} is measured with all outputs OPEN, all B inputs LOW and all other inputs at 4.5V, or all inputs at 4.5V.

Note 5: I_{CC2} is measured with all outputs OPEN and all inputs GROUNDED.

DM74LS283

Switching Characteristics							
at $V_{CC} = 5V$ and $T_A = 25^\circ C$							
Symbol	Parameter	From (Input) To (Output)	$R_L = 2\ k\Omega$				Units
			$C_L = 15\ pF$		$C_L = 50\ pF$		
			Min	Max	Min	Max	
t_{PLH}	Propagation Delay Time LOW-to-HIGH Level Output	C0 to $\Sigma 1, \Sigma 2$		24		28	ns
t_{PHL}	Propagation Delay Time HIGH-to-LOW Level Output	C0 to $\Sigma 1, \Sigma 2$		24		30	ns
t_{PLH}	Propagation Delay Time LOW-to-HIGH Level Output	C0 to $\Sigma 3$		24		28	ns
t_{PHL}	Propagation Delay Time HIGH-to-LOW Level Output	C0 to $\Sigma 3$		24		30	ns
t_{PLH}	Propagation Delay Time LOW-to-HIGH Level Output	C0 to $\Sigma 4$		24		28	ns
t_{PHL}	Propagation Delay Time HIGH-to-LOW Level Output	C0 to $\Sigma 4$		24		30	ns
t_{PLH}	Propagation Delay Time LOW-to-HIGH Level Output	A_i or B_i to Σ_i		24		28	ns
t_{PHL}	Propagation Delay Time HIGH-to-LOW Level Output	A_i or B_i to Σ_i		24		30	ns
t_{PLH}	Propagation Delay Time LOW-to-HIGH Level Output	C0 to C4		17		24	ns
t_{PHL}	Propagation Delay Time HIGH-to-LOW Level Output	C0 to C4		17		25	ns
t_{PLH}	Propagation Delay Time LOW-to-HIGH Level Output	A_i or B_i to C4		17		24	ns
t_{PHL}	Propagation Delay Time HIGH-to-LOW Level Output	A_i or B_i to C4		17		26	ns

Physical Dimensions inches (millimeters) unless otherwise noted

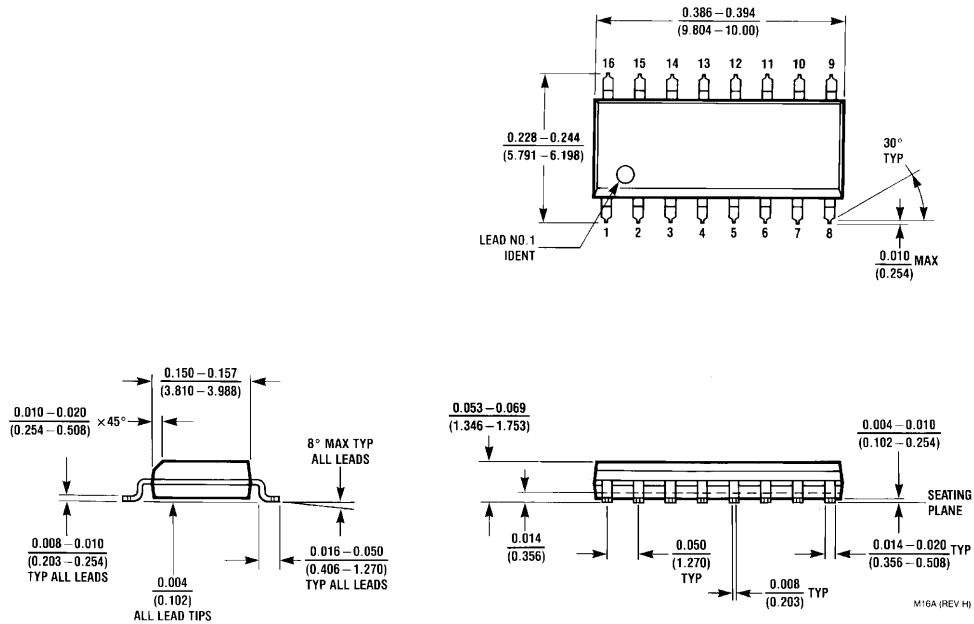

16-Lead Small Outline Integrated Circuit (SOIC), JEDEC MS-012, 0.150 Narrow Package Number M16A

DM74LS283 4-Bit Binary Adder with Fast Carry

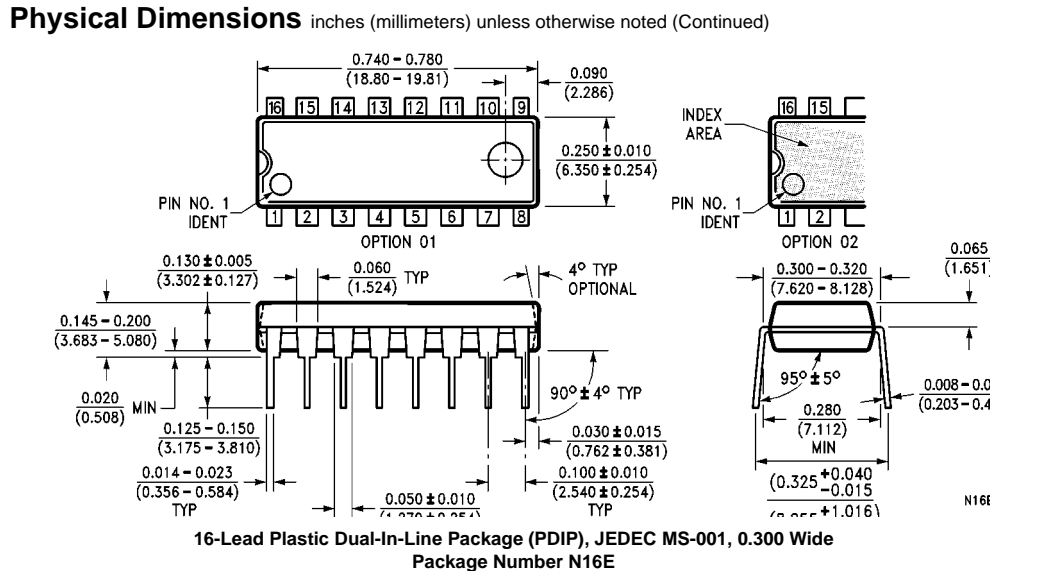

Fairchild does not assume any responsibility for use of any circuitry described, no circuit patent licenses are implied and Fairchild reserves the right at any time without notice to change said circuitry and specifications.

LIFE SUPPORT POLICY

FAIRCHILD'S PRODUCTS ARE NOT AUTHORIZED FOR USE AS CRITICAL COMPONENTS IN LIFE SUPPORT DEVICES OR SYSTEMS WITHOUT THE EXPRESS WRITTEN APPROVAL OF THE PRESIDENT OF FAIRCHILD SEMICONDUCTOR CORPORATION. As used herein:

1. Life support devices or systems are devices or systems which, (a) are intended for surgical implant into the body, or (b) support or sustain life, and (c) whose failure to perform when properly used in accordance with instructions for use provided in the labeling, can be reasonably expected to result in a significant injury to the user.
2. A critical component in any component of a life support device or system whose failure to perform can be reasonably expected to cause the failure of the life support device or system, or to affect its safety or effectiveness.

www.fairchildsemi.com