

HDMI COMPANION CHIP WITH STEP-UP DC-DC, I²C LEVEL SHIFTER, AND HIGH-SPEED ESD CLAMPS FOR PORTABLE APPLICATIONS

Check for Samples: [TPD12S015](#)

FEATURES

- HDMI 1.3 Data Rate
- HDMI High-Speed Differential Signals -3 dB Bandwidth Exceeds 6.4 Gbps
- Excellent Matching Capacitance (0.05 pF) in Each Differential Signal Pair
- Internal Boost Converter to Generate 5 V from a 2.3- to 5.5-V Battery Voltage
- HDMI Minimum Current Limit and Short-circuit Protection at 5VOUT Pin
- Flexible Power Saving Modes Through Separate Control Pins
- Auto Direction Sensing Level Shifting in the CEC, SDA, SCL Lines Drive up to 750pF Load
- Seamless Type C and Type D Connector Routing with Flow-Through Pin Mapping

- IEC 61000-4-2 (Level 4) System Level ESD Compliance
- Integrated I_{OFF} and Backdrive Current Protection
- Space-saving 1.6 mm × 2.8 mm WCSP (YFF) Package

APPLICATIONS

- Smart Phones
- Multimedia Phones
- Digital Camcorders
- Digital Still Cameras
- Portable Game Consoles

YFF PACKAGE
(TOP VIEW)

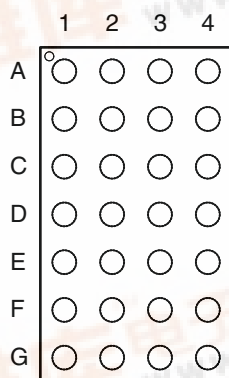

For package dimensions, see the Mechanical Drawing at the end of this document.

YFF PACKAGE PIN MAPPING

	1	2	3	4
A	LS_OE	V _{CCA}	D2+	D2-
B	SCL_A	CEC_A	GND	D1+
C	SDA_A	HPD_A	GND	D1-
D	CT_CP_HPD	GND	CEC_B	D0+
E	FB	GND	SCL_B	D0-
F	5VOUT	SW	SDA_B	CLK+
G	P _{GND}	V _{BAT}	HPD_B	CLK-

DESCRIPTION/ORDERING INFORMATION

The TPD12S015 is an integrated HDMI ESD solution. The device pin mapping matches the HDMI Type C and Type D connector with four differential pairs. This device offers eight low-capacitance ESD clamps, allowing HDMI 1.3 data rates. The integrated ESD clamps and resistors provide good matching between each differential signal pair, which allows an advantage over discrete ESD clamp solutions where variations between ESD clamps degrade the differential signal quality.



Please be aware that an important notice concerning availability, standard warranty, and use in critical applications of Texas Instruments semiconductor products and disclaimers thereto appears at the end of this data sheet.

PRODUCTION DATA information is current as of publication date. Products conform to specifications per the terms of the Texas Instruments standard warranty. Production processing does not necessarily include testing of all parameters.

Copyright © 2009–2010, Texas Instruments Incorporated



查询 TPD12S015 供应商

The TPD12S015 provides a regulated 5 V output (5VOUT) for sourcing the HDMI power line. The regulated 5 V output supplies up to 55 mA to the HDMI receiver. The control of 5VOUT and the hot plug detect (HPD) circuitry is independent of the LS_OE control signal and is controlled by the CT_CP_HPDP pin. This independent control enables the detection scheme (5VOUT + HPD) to be active before enabling the HDMI link.

There are three non-inverting bi-directional translation circuits for the SDA, SCL, and CEC lines. Each have a common power rail (V_{CCA}) on the A side from 1.1 V to 3.6V. On the B side, the SCL_B and SDA_B each have an internal 1.75 kΩ pullup connected to the regulated 5 V rail (5VOUT). The SCL and SDA pins meet the I²C specification and drive up to 750 pF loads. The CEC_B pin has an internal 27 kΩ pullup to an internal 3.3 V supply.

The HPD_B port has a glitch filter to avoid false detection due to the bouncing while inserting the HDMI plug.

The TPD12S015 provides IEC61000-4-2 (Level 4) ESD protection. This device is offered in a space-saving 1.6 mm x 2.8 mm wafer-level chip scale package [WCSP (YFF)] with 0.4-mm pitch.

ORDERING INFORMATION

T _A	PACKAGE ⁽¹⁾ (2)		ORDERABLE PART NUMBER	TOP-SIDE MARKING
-40°C to 85°C	WCSP – YFF	Tape and reel	TPD12S015YFFR	PN015

- (1) Package drawings, thermal data, and symbolization are available at www.ti.com/packaging.
- (2) For the most current package and ordering information, see the Package Option Addendum at the end of this document, or see the TI website at www.ti.com.

SYSTEM-LEVEL BLOCK DIAGRAM

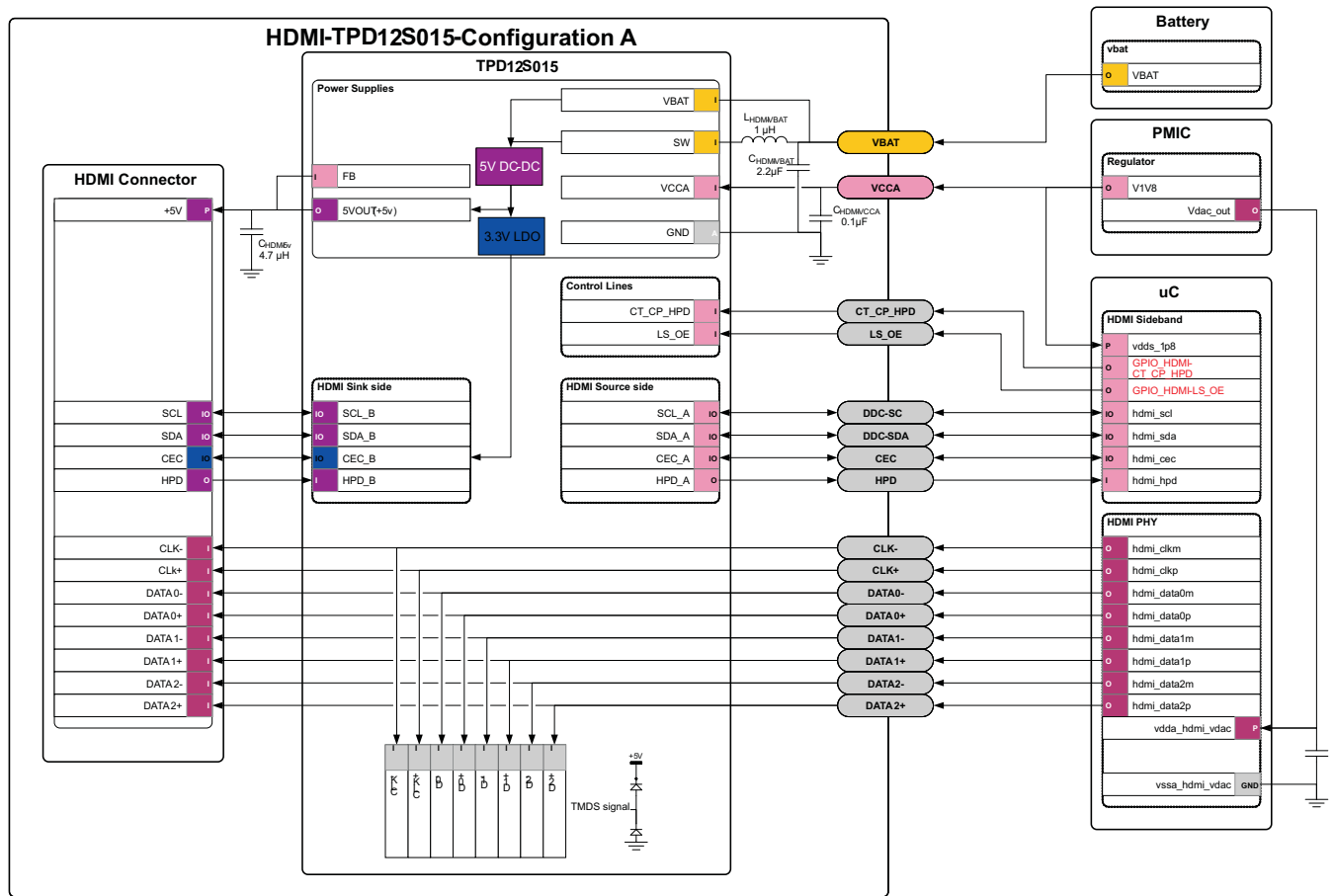

CIRCUIT BLOCK DIAGRAM

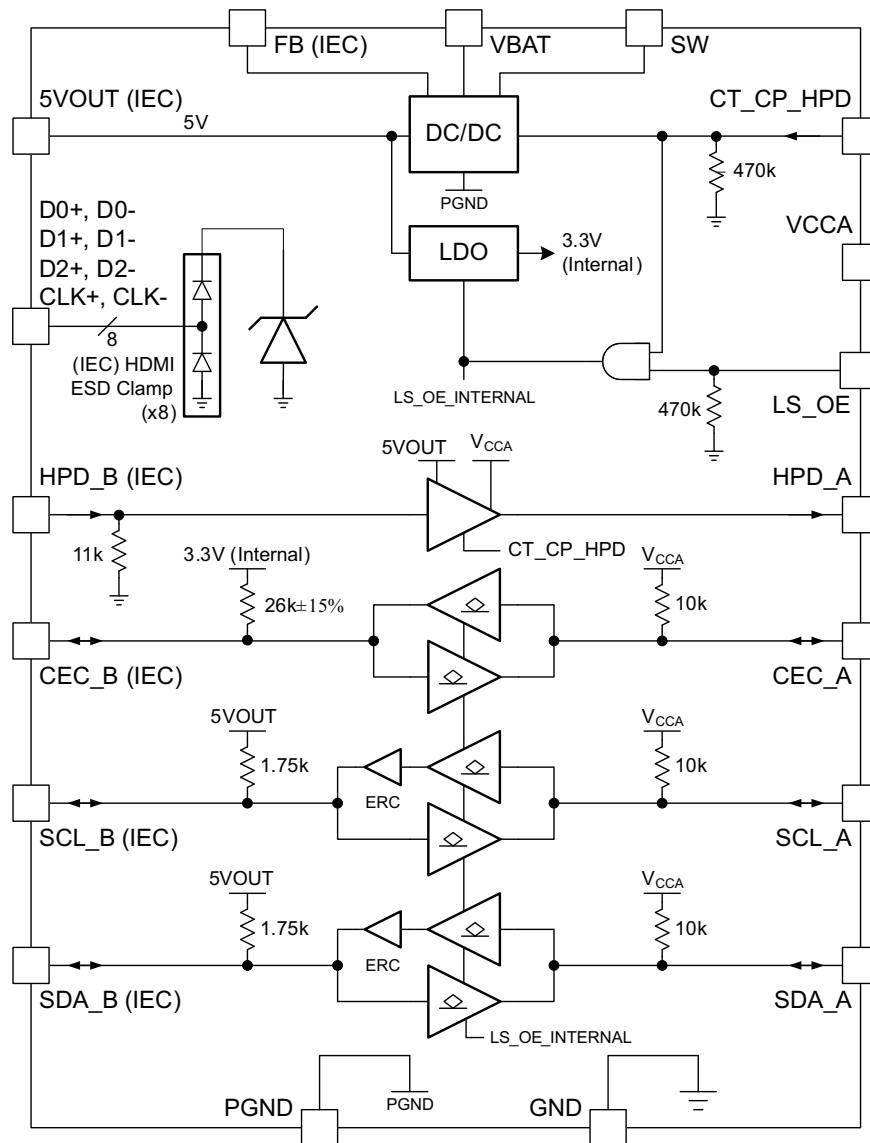

TERMINAL FUNCTIONS

TERMINAL		TYPE	DESCRIPTION
NAME	NO.		
5VOUT	F1	Pwr O	DC/DC output. The 5-V power pin can supply 55 mA regulated current to the HDMI receiver. Separate DC/DC converter control pin CT_CP_HPDP disables the DC/DC converter when operating at low-power mode.
CEC_A	B2	I/O	System-side CEC bus I/O. This pin is bi-directional and referenced to V_{CCA} .
CEC_B	D3	I/O	HDMI-side CEC bus I/O. This pin is bi-directional and referenced to the 3.3-V internal supply.
CLK-, CLK+	G4, F4	ESD	High-speed ESD clamp: provides ESD protection to the high-speed HDMI differential data lines
CT_CP_HPDP	D1	Ctrl	DC/DC Enable. Enables the DC/DC converter and HPD circuitry when CT_CP_HPDP = H. The CT_CP_HPDP is referenced to V_{CCA} .
D0-, D0+, D1-, D1+, D2-, D2+	E4, D4, C4, B4, A4, A3	ESD	High-speed ESD clamp: provides ESD protection to the high-speed HDMI differential data lines
FB	E1	I	Feedback input. This pin is a feedback control pin for the DC/DC converter. It must be connected to 5VOUT.
GND	B3, C3, D2, E2	-	Device ground
HPD_A	C2	O	System-side output for the hot plug detect. This pin is unidirectional and is referenced to V_{CCA} .
HPD_B	G3	I	HDMI-side input for the hot plug detect. This pin is unidirectional and is referenced to 5VOUT.
LS_OE	A1	Ctrl	Level shifter enable. This pin is referenced to V_{CCA} . Enables level shifters and LDO when OE = H.
P _{GND}	G1	-	DC/DC converter ground. This pin should be tied externally to the system GND plane. See board layout in applications section.
SCL_A	B1	I/O	System-side input/output for I ² C bus. This pin is bi-directional and referenced to V_{CCA} .
SCL_B	E3	I/O	HDMI-side input/output for I ² C bus. This pin is bi-directional and referenced to 5VOUT.
SDA_A	C1	I/O	System-side input/output for I ² C bus. This pin is bi-directional and referenced to V_{CCA} .
SDA_B	F3	I/O	HDMI-side input/output for I ² C bus. This pin is bi-directional and referenced to 5VOUT.
SW	F2	I	Switch input. This pin is the inductor input for the DC/DC converter.
V _{BAT}	G2	Supply	Battery supply. This voltage is typically 2.3 V to 5.5 V
V _{CCA}	A2	Supply	System-side supply. this voltage is typically 1.2 V to 3.3 V from the core microcontroller.

ABSOLUTE MAXIMUM RATINGS⁽¹⁾

over operating free-air temperature range (unless otherwise noted)

			MIN	MAX	UNIT
V _{CCA}	Supply voltage range			4.0	V
V _{BAT}	Supply voltage range		-0.3	6.5	
V _I	Input voltage range	SCL_A, SDA_A, CEC_A, CT_CP_HPDP, LS_OE	-0.3	4.0	V
		SCL_B, SDA_B, CEC_B, D, CLK	-0.3	6.0	
V _O	Voltage range applied to any output in the high-impedance or power-off state ⁽²⁾	SCL_A, SDA_A, CEC_A, HPD_A	-0.3	4.0	V
		SCL_B, SDA_B, CEC_B	-0.3	6.0	
	Voltage range applied to any output in the high or low state ⁽²⁾	SCL_A, SDA_A, CEC_A, HPD_A	-0.3	V _{CCA} + 0.3	
		SCL_B, SDA_B, CEC_B	-0.5	6.0	
I _{IK}	Input clamp current	V _I < 0		-50	mA
I _{OK}	Output clamp current	V _O < 0		-50	mA
I _{OUTMAX}	Continuous current through 5VOUT or GND			±100	mA
T _{stg}	Storage temperature range		-65	150	°C

(1) Stresses above these ratings may cause permanent damage. Exposure to "absolute maximum conditions" for extended periods may degrade device reliability. These are stress ratings only, and functional operation of the device at these or any other conditions beyond those specified is not implied.

(2) The input and output voltage ratings may be exceeded if the input and output clamp-current ratings are observed.

RECOMMENDED OPERATING CONDITIONS

over recommended operating free-air temperature range (unless otherwise noted)

			SUPPLY	MIN	TYP	MAX	UNIT
V _{CCA}	Supply voltage			1.1		3.6	V
V _{BAT}	Supply voltage			2.3		5.5	V
V _{IH}	High-level input voltage	SCL_A, SDA_A, CEC_A	V _{CCA} = 1.1 V to 3.6 V	0.7*V _{CCA}		V _{CCA}	V
		CT_CP_HPDP, LS_OE		1		V _{CCA}	
		SCL_B, SDA_B	5VOUT = 5.0 V	0.7*5VOUT		5VOUT	
		CEC_B		0.7*3.3V (internal)		3.3V (internal)	
		HPD_B		2.4		5VOUT	
V _{IL}	Low-level input voltage	SCL_A, SDA_A, CEC_A	V _{CCA} = 1.1 V to 3.6 V	-0.5		0.082*V _{CCA}	V
		CT_CP_HPDP, LS_OE		-0.5		0.4	
		SCL_B, SDA_B	5VOUT = 5.0 V	-0.5		0.3*5VOUT	
		CEC_B		-0.5		0.3*V _{3P3}	
		HPD_B		0		0.8	
V _{ILC}	Low-level input voltage (contention)	SCL_A, SDA_A, CEC_A	V _{CCA} = 1.1 V to 3.6 V	-0.5		0.065*V _{CCA}	V
V _{OL} – V _{ILC}	Delta between V _{OL} and V _{ILC}	SCL_A, SDA_A, CEC_A	V _{CCA} = 1.1 V to 3.6 V		0.1*V _{CC} _A		V
T _A	Operating free-air temperature			-40		85	°C

ESD RATINGS

PARAMETER	PINS	TYP	UNIT
Human Body Model JESD22 A114-B	ALL	2.5	kV
Charged Device Model JESD22 C101	ALL	1000	V
IEC 61000-4-2 Contact Discharge	Dx, CLKx, x_B, 5VOUT, FB	±8	kV
Human Body Model	Dx, CLKx, x_B, 5VOUT, FB	±15	kV

ELECTRICAL CHARACTERISTICS

I_{CC}

PARAMETER		PIN	TEST CONDITIONS	MIN	TYP	MAX	UNIT
I _{CCA}	Standby	V _{CCA}	I/O = High			2	µA
	Active					15	
I _{CCB}	Standby	V _{BAT}	CT_CP_HPDP=L, LS_OE=L, HPD_B=L			2	µA
	DC/DC and HPD active		CT_CP_HPDP=H, LS_OE=L, HPD_B=L	30	50		
	DC/DC, HPD, DDC, CEC active		CT_CP_HPDP=H LS_OE=H, HPD_B=L, I/O =H	225	300		

High-Speed ESD Lines: Dx, CLK

PARAMETER		TEST CONDITIONS		MIN	TYP	MAX	UNIT
I _{OFF}	Current from IO port to supply pins	V _{CC} = 0 V, V _{IO} = 3.3 V			0.01	0.5	µA
V _{DL}	Diode forward voltage	I _D = 8 mA,	Lower clamp diode		0.85	1.0	V
R _{DYN}	Dynamic resistance	I = 1 A	D, CLK		1		Ω
C _{IO}	IO capacitance	V _{IO} = 2.5 V	D, CLK		1.3		pF
V _{BR}	Break-down voltage	I _{IO} = 1mA		9		12	V

DC-DC Converter

PARAMETER		TEST CONDITIONS		MIN	TYP	MAX	UNIT
V _{BAT}	Input voltage range			2.3		5.5	V
5VOUT	Total DC output voltage	Includes voltage references, DC load / line regulations, process and temperature		4.9	5	5.13	V
TOVA	Total output voltage accuracy	Includes voltage references, DC load / line regulations, transient load / line regulations, ripple, process and temperature		4.8	5	5.3	V
V _{O_Ripple}	Output voltage ripple, loaded	I _O = 65 mA				20	mV (p-p)
F _{clk}	Internal operating frequency	V _{BAT} = 2.3 V to 5.5 V			3.5		MHz
t _{start}	Startup time	From CT_CP_HPDP input to 5 V power output 90% point				300	µs
I _O	Output current	V _{BAT} = 2.3 V to 5.5 V		55			mA
	Reverse leakage current V _O	CT_CP_HPDP= L, V _O = 5.5 V				2.5	µA
	Leakage current from battery to V _O	CT_CP_HPDP= L				5	µA
V _{BATUV}	Under voltage lockout threshold	Falling			2		V
		Rising			2.1		V
V _{OVC}	Input overvoltage threshold	Falling			5.9		V
		Rising			6.0		V
	Line transient response	V _{BAT} = 3.6 V, a pulse of 217Hz 600 mVp-p square wave, I _O = 20/65 mA			±25	±50	mVpk
	Load transient response	V _{BAT} = 3.6 V, I _O = 5 to 65 mA, pulse of 10 µs, t _r = t _f = 0.1 µs			50		mVpk

DC-DC Converter (continued)

PARAMETER		TEST CONDITIONS	MIN	TYP	MAX	UNIT
I_{DD} (idle)	Power supply current from V_{BAT} to DC/DC, enabled, unloaded	$I_O = 0$ mA		30	50	μ A
I_{DD} (disabled)	Power supply current from V_{BAT} , DC/DC Disabled, Unloaded	$V_{BAT} = 2.3$ V to 5.5 V, $I_O = 0$ mA, CT_CP_HPDLow			2	μ A
I_{DD} (system off)	Power supply current from V_{BAT} , $V_{CCA} = 0$ V	$V_{CCA} = 0$ V			5	μ A
I_{inrush} (startup)	Inrush current, average over $T_{startup}$ time	$V_{BAT} = 2.3$ V to 5.5 V, $I_O = 65$ mA		100		mA
T_{SD}	Thermal shutdown	Increasing junction temperature		140		$^{\circ}$ C
	Thermal shutdown hysteresis	Decreasing junction temperature		20		$^{\circ}$ C
I_{SC}	Short circuit current limit from output	5 Ω short to GND			500	mA

Passive Components

PARAMETER		TYP	UNIT
L_{IN}	External inductor, 0805 footprint	1	μ H
C_{IN}	Input capacitor, 0603 footprint	4.7	μ F
C_{OUT}	Output capacitor, 0603 footprint	4.7	μ F
C_{VCCA}	Input capacitor, 0402 footprint	0.1	μ F

Voltage Level Shifter: SCL, SDA Lines (x_A/x_B Ports)
 $T_A = -40^{\circ}$ C to 85° C unless otherwise specified

PARAMETER		TEST CONDITIONS	V_{CCA}	MIN	TYP	MAX	UNIT
V_{OHA}		$I_{OH} = -20$ μ A, $V_I = V_{IH}$	1.1 V to 3.6 V	$V_{CCA} \times 0.8$			V
V_{OLA}		$I_{OL} = 20$ mA, $V_I = V_{IL}$	1.1 V to 3.6 V	$V_{CCA} \times 0.17$			V
V_{OHB}		$I_{OH} = -20$ μ A, $V_I = V_{IH}$		$5V_{OUT} \times 0.9$			V
V_{OLB}		$I_{OL} = 3$ mA, $V_I = V_{IL}$				0.4	V
ΔV_T hysteresis	SDx_A ($V_{T+} - V_{T-}$)		1.1 V to 3.6 V		40		mV
	SDx_B ($V_{T+} - V_{T-}$)		1.1 V to 3.6 V		400		
R_{PU}	(Internal pullup)	SCL_A, SDA_A,	Internal pullup connected to V_{CCA} rail		10		k Ω
		SCL_B, SDA_B,	Internal pullup connected to 5 V rail		1.75		
$I_{PULLUPAC}$	Transient boosted pullup current (rise time accelerator)	SCL_B, SDA_B,	Internal pullup connected to 5 V rail		15		mA
I_{OFF}	A port	$V_{CCA} = 0$ V, V_I or $V_O = 0$ to 3.6 V	0 V			± 5	μ A
	B port	$5V_{OUT} = 0$ V, V_I or $V_O = 0$ to 5.5 V	0 V to 3.6 V			± 5	
I_{OZ}	B port	$V_O = V_{CCO}$ or GND	1.1 V to 3.6 V			± 5	μ A
	A port	$V_I = V_{CCI}$ or GND	1.1 V to 3.6 V			± 5	

Voltage Level Shifter: CEC Lines (x_A/x_B Ports)

T_A = -40°C to 85°C unless otherwise specified

PARAMETER		TEST CONDITIONS	V _{CCA}	MIN	TYP	MAX	UNIT
V _{OHA}		I _{OH} = -20 μA, V _I = V _{IH}	1.1 V to 3.6 V	V _{CCA} × 0.8			V
V _{OLA}		I _{OL} = 20 mA, V _I = V _{IL}	1.1 V to 3.6 V	V _{CCA} × 0.17			V
V _{OHB}		I _{OH} = -20 μA, V _I = V _{IH}		V _{3P3} × 0.9			V
V _{OLB}		I _{OL} = 3 mA, V _I = V _{IL}				0.4	V
ΔV _T hysteresis	CEC_A (V _{T+} - V _{T-})		1.1 V to 3.6 V	40			mV
	CEC_B (V _{T+} - V _{T-})		1.1 V to 3.6 V	300			
R _{PU}	(Internal pullup)	CEC_A Internal pullup connected to V _{CCA} rail		10			kΩ
		CEC_B Internal pullup connected to internal 3.3 V rail		26			
I _{OFF}	A port	V _{CCA} = 0 V, V _I or V _O = 0 to 3.6 V	0 V			±5	μA
	B port	5VOUT = 0 V, V _I or V _O = 0 to 5.5 V	0 V to 3.6 V			±1.8	
I _{OZ}	B port	V _O = V _{CCO} or GND	1.1 V to 3.6 V			±5	μA
	A port	V _I = V _{CCI} or GND	1.1 V to 3.6 V			±5	

Voltage Level Shifter: HPD Line (x_A/x_B Ports)

T_A = -40°C to 85°C unless otherwise specified

PARAMETER		TEST CONDITIONS	V _{CCA}	MIN	TYP	MAX	UNIT
V _{OHA}		I _{OH} = -3 mA, V _I = V _{IH}	1.1 V to 3.6 V	V _{CCA} × 0.7			V
V _{OLA}		I _{OL} = 3 mA, V _I = V _{IL}	1.1 V to 3.6 V	V _{CCA} × 0.17			V
ΔV _T hysteresis	HPD_B (V _{T+} - V _{T-})		1.1 V to 3.6 V	700			mV
R _{PD}	(Internal pulldown)	HPD_B, Internal pulldown connected to GND		11			kΩ
I _{OFF}	A port	V _O = V _{CCO} or GND	0 V			±5	μA
I _{OZ}	A port	V _I = V _{CCI} or GND	3.6 V			±5	μA

LS_OE, CT_CP_HPDP

T_A = -40°C to 85°C unless otherwise specified

PARAMETER	TEST CONDITIONS	V _{CCA}	MIN	TYP	MAX	UNIT
I _I	V _I = V _{CCA} or GND	1.1 V to 3.6 V			±12	μA

I/O Capacitance

T_A = -40°C to 85°C unless otherwise specified

PARAMETER	TEST CONDITIONS	V _{CCA}	MIN	TYP	MAX	UNIT
C _I	Control inputs V _I = 1.89 V or GND	1.1 V to 3.6 V		7.1	8.5	pF
C _{IO}	A port V _O = 1.89 V or GND	1.1 V to 3.6 V		8.3	9.5	pF
	B port V _O = 5.0 V or GND	1.1 V to 3.6 V		15	16.5	pF

SWITCHING CHARACTERISTICS

PARAMETER		TEST CONDITIONS	MIN	TYP	MAX	UNIT
C _L	Bus load capacitance (B side)				750	pF
	Bus load capacitance (A side)				15	

Voltage Level Shifter: SCL, SDA Lines (x_A & x_B ports); V_{CCA} = 1.2V

 V_{CCA} = 1.2 V

PARAMETER		PINS	TEST CONDITIONS	MIN	TYP	MAX	UNIT
t _{PHL}	Propagation delay	A to B	DDC Channels Enabled		344		ns
		B to A			335		
t _{PLH}	Propagation delay	A to B	DDC Channels Enabled		452		ns
		B to A			178		
t _f	A port fall time	A Port	DDC Channels Enabled		138		ns
	B port fall time	B Port			83		
t _r	A port rise time	A Port	DDC Channels Enabled		194		ns
	B port rise time	B Port			92		
f _{MAX}	Maximum switching frequency		DDC Channels Enabled	400			kHz

Voltage Level Shifter: CEC Line (x_A & x_B ports); V_{CCA} = 1.2V

 V_{CCA} = 1.2 V

PARAMETER		PINS	TEST CONDITIONS	MIN	TYP	MAX	UNIT
t _{PLH}	Propagation delay	A to B	CEC Channels Enabled		445		ns
		B to A			337		
t _{PLH}	Propagation delay	A to B	CEC Channels Enabled		13		μs
		B to A			0.266		
t _f	A port fall time	A Port	CEC Channels Enabled		140		ns
	B port fall time	B Port			96		
t _r	A port rise time	A Port	CEC Channels Enabled		202		ns
	B port rise time	B Port			15		

Voltage Level Shifter: HPD Line (x_A & x_B ports); V_{CCA} = 1.2V

 V_{CCA} = 1.2 V

PARAMETER		PINS	TEST CONDITIONS	MIN	TYP	MAX	UNIT
t _{PLH}	Propagation delay	B to A	CEC Channels Enabled		10		μs
t _{PLH}		B to A			9		
t _f	A port fall time	A Port	CEC Channels Enabled		0.67		ns
t _r	A port rise time	A Port	CEC Channels Enabled		0.74		ns

Voltage Level Shifter: SCL, SDA Lines (x_A & x_B ports); V_{CCA} = 1.5V

 V_{CCA} = 1.5 V

PARAMETER		PINS	TEST CONDITIONS	MIN	TYP	MAX	UNIT
t _{PLH}	Propagation delay	A to B	DDC Channels Enabled		335		ns
		B to A			265		
t _{PLH}	Propagation delay	A to B	DDC Channels Enabled		438		
		B to A			169		

Voltage Level Shifter: SCL, SDA Lines (x_A & x_B ports); VCCA = 1.5V (continued)
V_{CCA} = 1.5 V

PARAMETER		PINS	TEST CONDITIONS	MIN	TYP	MAX	UNIT
t _f	A port fall time	A Port	DDC Channels Enabled		110		ns
	B port fall time	B Port			83		
t _r	A port rise time	A Port	DDC Channels Enabled		190		ns
	B port rise time	B Port			92		
f _{MAX}	Maximum switching frequency		DDC Channels Enabled	400			kHz

Voltage Level Shifter: CEC Line (x_A & x_B ports); VCCA = 1.5V
V_{CCA} = 1.5 V

PARAMETER		PINS	TEST CONDITIONS	MIN	TYP	MAX	UNIT
t _{PLH}	Propagation delay	A to B	CEC Channels Enabled		437		ns
		B to A			267		
t _{PLH}		A to B			13		μs
		B to A			0.264		
t _f	A port fall time	A Port	CEC Channels Enabled		110		ns
	B port fall time	B Port			96		
t _r	A port rise time	A Port	CEC Channels Enabled		202		ns
	B port rise time	B Port			15		

Voltage Level Shifter: HPD Line (x_A & x_B ports); VCCA = 1.5V
V_{CCA} = 1.5 V

PARAMETER		PINS	TEST CONDITIONS	MIN	TYP	MAX	UNIT
t _{PLH}	Propagation delay	B to A	CEC Channels Enabled		10		μs
		B to A			9		
t _f	A port fall time	A Port	CEC Channels Enabled		0.47		ns
t _r	A port rise time	A Port	CEC Channels Enabled		0.51		ns

Voltage Level Shifter: SCL, SDA Lines (x_A & x_B ports); VCCA = 1.8V
V_{CCA} = 1.8 V

PARAMETER		PINS	TEST CONDITIONS	MIN	TYP	MAX	UNIT
t _{PLH}	Propagation delay	A to B	DDC Channels Enabled		334		ns
		B to A			229		
t _{PLH}		A to B			431		ns
		B to A			169		
t _f	A port fall time	A Port	DDC Channels Enabled		94		ns
	B port fall time	B Port			83		
t _r	A port rise time	A Port	DDC Channels Enabled		191		ns
	B port rise time	B Port			92		
f _{MAX}	Maximum switching frequency		DDC Channels Enabled	400			kHz

Voltage Level Shifter: CEC Line (x_A & x_B ports); VCCA = 1.8V
 $V_{CCA} = 1.8\text{ V}$

PARAMETER		PINS	TEST CONDITIONS	MIN	TYP	MAX	UNIT
t_{PLH}	Propagation delay	A to B	CEC Channels Enabled		441		ns
		B to A			231		
t_{PLH}		A to B			13		μs
		B to A			0.26		
t_f	A port fall time	A Port	CEC Channels Enabled		94		ns
	B port fall time	B Port			96		
t_r	A port rise time	A Port	CEC Channels Enabled		201		ns
	B port rise time	B Port			15		μs

Voltage Level Shifter: HPD Line (x_A & x_B ports); VCCA = 1.8V
 $V_{CCA} = 1.8\text{ V}$

PARAMETER		PINS	TEST CONDITIONS	MIN	TYP	MAX	UNIT
t_{PLH}	Propagation delay	B to A	CEC Channels Enabled		10		μs
		B to A			9		
t_f	A port fall time	A Port	CEC Channels Enabled		0.41		ns
t_r	A port rise time	A Port	CEC Channels Enabled		0.45		ns

Voltage Level Shifter: SCL, SDA Lines (x_A & x_B ports); VCCA = 2.5V
 $V_{CCA} = 2.5\text{ V}$

PARAMETER		PINS	TEST CONDITIONS	MIN	TYP	MAX	UNIT
t_{PLH}	Propagation delay	A to B	DDC Channels Enabled		330		ns
		B to A			182		
t_{PLH}		A to B			423		
		B to A			166		
t_f	A port fall time	A Port	DDC Channels Enabled		79		ns
	B port fall time	B Port			83		
t_r	A port rise time	A Port	DDC Channels Enabled		188		ns
	B port rise time	B Port			92		
f_{MAX}	Maximum switching frequency		DDC Channels Enabled	400			kHz

Voltage Level Shifter: CEC Line (x_A & x_B ports); VCCA = 2.5V
 $V_{CCA} = 2.5\text{ V}$

PARAMETER		PINS	TEST CONDITIONS	MIN	TYP	MAX	UNIT
t_{PLH}	Propagation delay	A to B	CEC Channels Enabled		454		ns
		B to A			184		
t_{PLH}		A to B			13		μs
		B to A			0.255		
t_f	A port fall time	A Port	CEC Channels Enabled		79		ns
	B port fall time	B Port			96		
t_r	A port rise time	A Port	CEC Channels Enabled		194		ns
	B port rise time	B Port			15		μs

Voltage Level Shifter: HPD Line (x_A & x_B ports); VCCA = 2.5V
V_CCA = 2.5 V

PARAMETER		PINS	TEST CONDITIONS	MIN	TYP	MAX	UNIT
t _{PLH}	Propagation delay	B to A	CEC Channels Enabled		10		μs
t _{PLH}		B to A			9		
t _f	A port fall time	A Port	CEC Channels Enabled		0.37		ns
t _r	A port rise time	A Port	CEC Channels Enabled		0.39		ns

Voltage Level Shifter: SCL, SDA Lines (x_A & x_B ports); VCCA = 3.3V
V_CCA = 3.3 V

PARAMETER		PINS	TEST CONDITIONS	MIN	TYP	MAX	UNIT
t _{PLH}	Propagation delay	A to B	DDC channels enabled		323		ns
t _{PLH}		B to A			158		
		A to B			421		
		B to A			162		
t _f	A port fall time	A Port	DDC channels enabled		71		ns
	B port fall time	B Port			84		
t _r	A port rise time	A Port	DDC channels enabled		188		ns
	B port rise time	B Port			92		
f _{MAX}	Maximum switching frequency		DDC channels enabled	400			kHz

Voltage Level Shifter: CEC Line (x_A & x_B ports); VCCA = 3.3V
V_CCA = 3.3 V

PARAMETER		PINS	TEST CONDITIONS	MIN	TYP	MAX	UNIT
t _{PLH}	Propagation delay	A to B	CEC channels enabled		450		ns
t _{PLH}		B to A			160		
		A to B			13		μs
		B to A			0.251		
t _f	A port fall time	A Port	CEC channels enabled		71		ns
	B port fall time	B Port			96		
t _r	A port rise time	A Port	CEC channels enabled		194		ns
	B port rise time	B Port			15		

Voltage Level Shifter: HPD Line (x_A & x_B ports); VCCA = 3.3V
V_CCA = 3.3 V

PARAMETER		PINS	TEST CONDITIONS	MIN	TYP	MAX	UNIT
t _{PLH}	Propagation delay	B to A	CEC channels enabled		10		μs
t _{PLH}		B to A			9		
t _f	A port fall time	A Port	CEC channels enabled		0.35		ns
t _r	A port rise time	A Port	CEC channels enabled		0.37		ns

APPLICATION INFORMATION

DDC/CEC Level Shift Circuit Operation

The TPD12S015 enables DDC translation from V_{CCA} (system side) voltage levels to 5V (HDMI cable side) voltage levels without degradation of system performance. The TPD12S015 contains two bidirectional open-drain buffers specifically designed to support up-translation/down-translation between the low voltage, V_{CCA} side DDC-bus and the 5V DDC-bus. The port B I/Os are over-voltage tolerant to 5.5 V even when the device is unpowered. After powerup and with the LS_OE and CT_CP_HPDP pins high, a low level on port A (below approximately $V_{ILC} = 0.08 * V_{CCA}$ V) turns the corresponding port B driver (either SDA or SCL) on and drives port B down to V_{OLB} V. When port A rises above approximately $0.10 * V_{CCA}$ V, the port B pulldown driver is turned off and the internal pullup resistor pulls the pin high. When port B falls first and goes below $0.3 * 5V_{OUT}$, a CMOS hysteresis input buffer detects the falling edge, turns on the port A driver, and pulls port A down to approximately $V_{OLA} = 0.16 * V_{CCA}$ V. The port B pulldown is not enabled unless the port A voltage goes below V_{ILC} . If the port A low voltage goes below V_{ILC} , the port B pulldown driver is enabled until port A rises above $(V_{ILC} + \Delta V_{T-HYSTA})$, then port B, if not externally driven LOW, will continue to rise being pulled up by the internal pullup resistor.

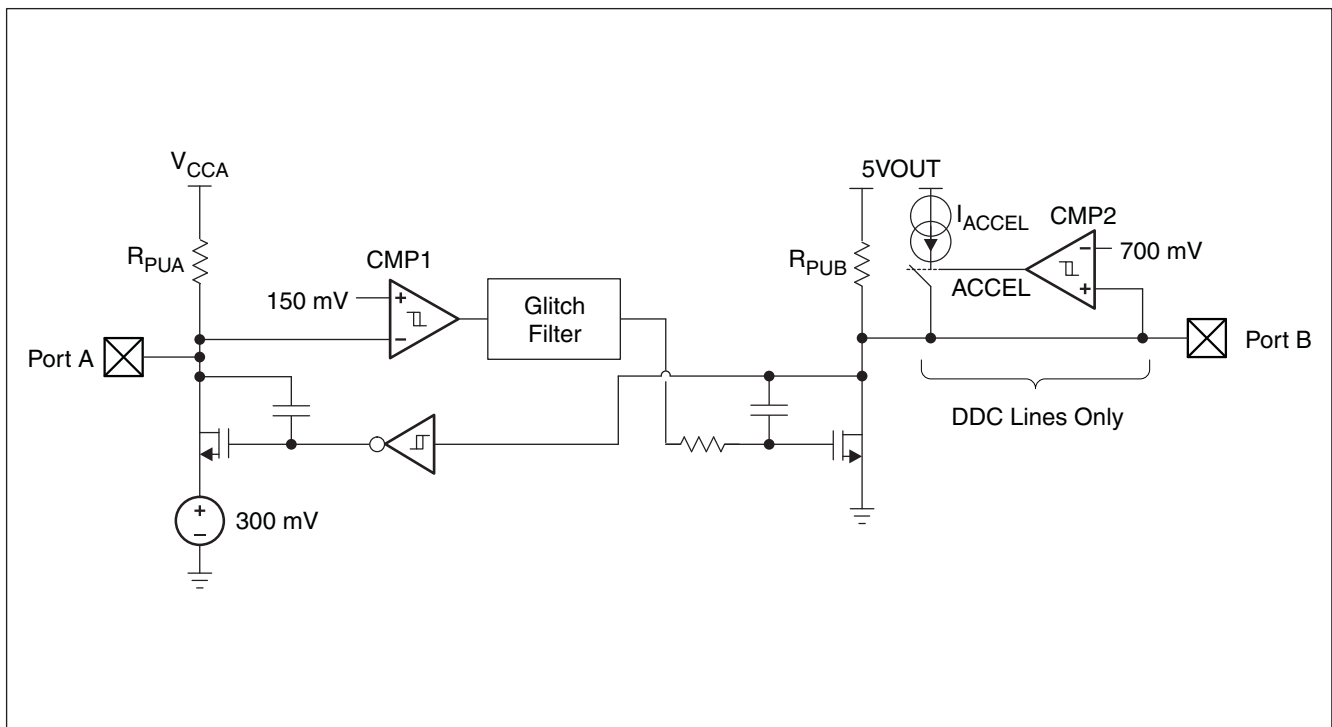

Figure 1. DDC/CEC Level Shifter Block Diagram

DDC/CEC Level Shifter Operational Notes for $V_{CCA} = 1.8$ V

- The threshold of CMP1 is $\sim 150\text{mV}$ +/- the 40mV of total hysteresis.
- The comparator will trip for a falling waveform at $\sim 130\text{mV}$
- The comparator will trip for a rising waveform at $\sim 170\text{mV}$
- To be recognized as a zero, the level at Port A must first go below 130mV (V_{ILC} in spec) and then stay below 170mV (V_{ILA} in spec)
- To be recognized as a one, the level at A must first go above 170mV and then stay above 130mV
- V_{ILC} is set to 110mV in Electrical Characteristics Table to give some margin to the 130mV
- V_{ILA} is set to 140mV in the Electrical Characteristics Table to give some margin to the 170mV
- V_{IHA} is set to 70% of V_{CCA} to be consistent with standard CMOS levels

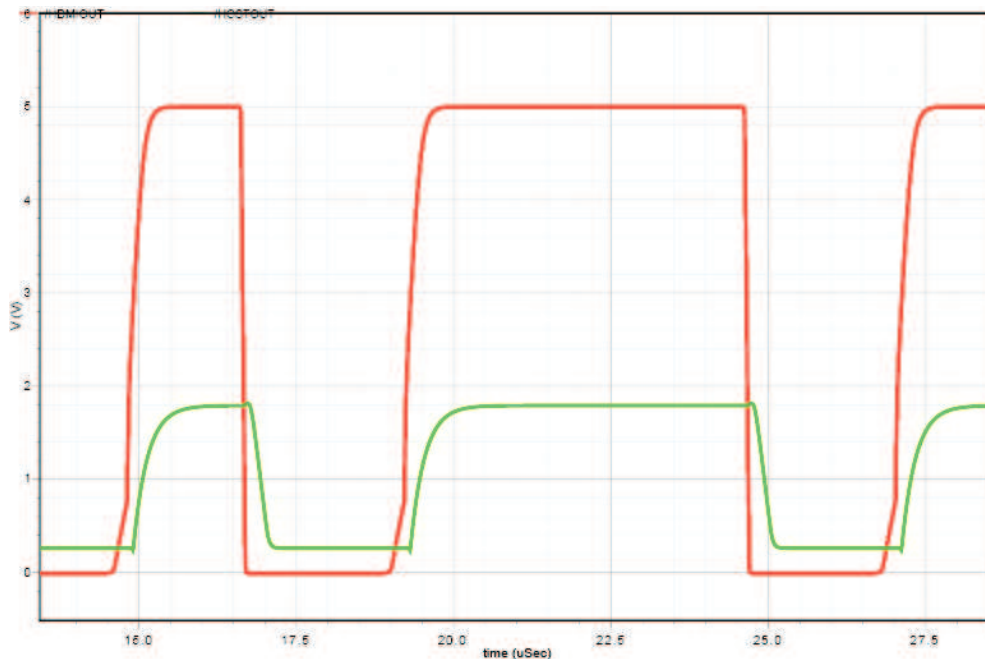

Figure 2. DDC/CEC Level Shifter Operation (B to A Direction)

Rise-Time Accelerators

The HDMI cable side of the DDC lines incorporates rise-time accelerators to support the high capacitive load on the HDMI cable side. The rise time accelerator boosts the cable side DDC signal independent of which side of the bus is releasing the signal.

Remark

Ground offset between the TPD12S015 ground and the ground of devices on port A of the TPD12S015 must be avoided. The reason for this cautionary remark is that a CMOS/NMOS open-drain capable of sinking 3 mA of current at 0.4 V will have an output resistance of 133 ohms or less ($R = E / I$). Such a driver will share enough current with the port A output pull-down of the TPD12S015 to be seen as a LOW as long as the ground offset is zero. If the ground offset is greater than 0 V, then the driver resistance must be less. Since VILC can be as low as 90 mV at cold temperatures and the low end of the current distribution, the maximum ground offset should not exceed 50 mV. Bus repeaters that use an output offset are not interoperable with the port A of the TPD12S015 as their output LOW levels will not be recognized by the TPD12S015 as a LOW. If the TPD12S015 is placed in an application where the VIL of port A of the TPD12S015 does not go below its VILC it will pull port B LOW initially when port A input transitions LOW but the port B will return HIGH, so it will not reproduce the port A input on port B. Such applications should be avoided. Port B is interoperable with all I²C bus slaves, masters and repeaters.

CEC Level Shift Operation

The CEC level shift function operates in the same manner as the DDC lines except that the CEC line does not need the rise time accelerator function.

Internal Pullup Resistor

The TPD12S015 has incorporated all the required pullup and pulldown resistors at the interface pins. The system is designed to work properly with no external pullup resistors on the DDC, CEC, and HPD lines. For proper system operation no external resistors should be placed at the A and B ports. If there is internal pullups at the host processor, they should be disabled.

Power-Save Mode

The TPD12S015 integrates a power save mode to improve efficiency at light load. In power save mode the converter only operates when the output voltage trips below a set threshold voltage. It ramps up the output voltage with several pulses and goes into power save mode once the output voltage exceeds the set threshold voltage. The PFM mode is left and PWM mode entered in case the output current can not longer be supported in PFM mode.

Under-Voltage Lockout

The under voltage lockout circuit prevents the DC/DC converter from malfunctioning at low input voltages and from excessive discharge of the battery. It disables the output stage of the converter once the falling V_{IN} trips the under-voltage lockout threshold V_{BATUV} . The under-voltage lockout threshold V_{BATUV} for falling V_{IN} is typically 2.0V. The device starts operation once the rising V_{IN} trips under-voltage lockout threshold V_{BATUV} again at typical 2.1 V.

Enable

The DC/DC converter is enabled when the CT_CP_HPDP is set to high. At first, the internal reference is activated and the internal analog circuits are settled. Afterwards, the soft start is activated and the output voltage is ramped up. The output voltage reaches its nominal value in typically 250 μ s after the device has been enabled. The CT_CP_HPDP input can be used to control power sequencing in a system with various DC/DC converters. The CT_CP_HPDP pin can be connected to the output of another converter, to drive the EN pin high and getting a sequencing of supply rails. With CT_CP_HPDP = GND, the dc/dc enters shutdown mode.

Soft Start

The DC/DC converter has an internal soft start circuit that controls the ramp up of the output voltage. The output voltage reaches its nominal value within t_{Start} of typically 250 μ s after CT_CP_HPDP pin has been pulled to high level. The output voltage ramps up from 5% to its nominal value within t_{Ramp} of 300 μ s. This limits the inrush current in the converter during start up and prevents possible input voltage drops when a battery or high impedance power source is used. During soft start, the switch current limit is reduced to 300 mA until the output voltage reaches V_{IN} . Once the output voltage trips this threshold, the device operates with its nominal current limit ILIMF.

Inductor Selection

To make sure that the TPD12S015 devices can operate, an inductor must be connected between pin V_{BAT} and pin L. A boost converter normally requires two main passive components for storing energy during the conversion. A boost inductor and a storage capacitor at the output are required. To select the boost inductor, it is recommended to keep the possible peak inductor current below the current limit threshold of the power switch in the chosen configuration. The highest peak current through the inductor and the switch depends on the output load, the input (V_{BAT}), and the output voltage (5VOUT). Estimation of the maximum average inductor current can be done using [Equation 1](#).

$$I_{L_MAX} \approx I_{OUT} \times \frac{V_{OUT}}{\eta \times V_{IN}} \quad (1)$$

For example, for an output current of 55 mA at 5VOUT, approx 150 mA of average current flows through the inductor at a minimum input voltage of 2.3 V.

The second parameter for choosing the inductor is the desired current ripple in the inductor. Normally, it is advisable to work with a ripple of less than 20% of the average inductor current. A smaller ripple reduces the magnetic hysteresis losses in the inductor, as well as output voltage ripple and EMI. But in the same way, regulation time at load changes rises. In addition, a larger inductor increases the total system size and cost. With these parameters, it is possible to calculate the value of the minimum inductance by using [Equation 2](#).

$$L_{MIN} \approx \frac{V_{IN} \times (V_{OUT} - V_{IN})}{\Delta I_L \times f \times V_{OUT}} \quad (2)$$

Parameter f is the switching frequency and ΔI_L is the ripple current in the inductor, i.e., $20\% \times I_L$. With this calculated value and the calculated currents, it is possible to choose a suitable inductor. In typical applications a $1.0 \mu\text{H}$ inductance is recommended. The device has been optimized to operate with inductance values between $1.0 \mu\text{H}$ and $1.3 \mu\text{H}$. It is recommended that an inductance value of at least $1.0 \mu\text{H}$ is used, even if Equation 2 yields something lower. Care has to be taken that load transients and losses in the circuit can lead to higher currents as estimated in Equation 3. Also, the losses in the inductor caused by magnetic hysteresis losses and copper losses are a major parameter for total circuit efficiency.

With the chosen inductance value, the peak current for the inductor in steady state operation can be calculated. Equation 3 shows how to calculate the peak current I .

$$I_{L(\text{peak})} = \frac{V_{IN} \times D}{2 \times f \times L} + \frac{I_{OUT}}{(1-D) \times \eta} \quad (3)$$

$$D = \frac{V_{OUT} - V_{IN}}{V_{OUT}}$$

where

This would be the critical value for the current rating for selecting the inductor. It also needs to be taken into account that load transients and error conditions may cause higher inductor currents.

Input Capacitor

Because of the nature of the boost converter having a pulsating input current, a low ESR input capacitor is required to prevent large voltage transients that can cause misbehavior of the device or interferences with other circuits in the system. At least $1.2 \mu\text{F}$ input capacitor is recommended to improve transient behavior of the regulator and EMI behavior of the total power supply circuit. It is recommended to place a ceramic capacitor as close as possible to the V_{IN} and GND pins and better to use a $4.7 \mu\text{F}$ capacitor, in order to improve the input noise filtering.

Output Capacitor

For the output capacitor, it is recommended to use small ceramic capacitors placed as close as possible to the V_{OUT} and GND pins of the IC. If, for any reason, the application requires the use of large capacitors which can not be placed close to the IC, using a smaller ceramic capacitor in parallel to the large one is recommended. This small capacitor should be placed as close as possible to the V_{OUT} and GND pins of the IC. To get an estimate of the recommended minimum output capacitance, Equation 4 can be used.

$$C_{\text{min}} = \frac{I_{OUT} \times (V_{OUT} - V_{IN})}{f \times \Delta V \times V_{OUT}} \quad (4)$$

Parameter f is the switching frequency and ΔV is the maximum allowed ripple. With a chosen ripple voltage of 10 mV , a minimum effective capacitance of $2.7 \mu\text{F}$ is needed. The total ripple is larger due to the ESR of the output capacitor. This additional component of the ripple can be calculated using $\Delta V_{\text{ESR}} = I_{OUT} \times R_{\text{ESR}}$

A capacitor with a value in the range of the calculated minimum should be used. This is required to maintain control loop stability. There are no additional requirements regarding minimum ESR. There is no upper limit for the output capacitance value. Larger capacitors cause lower output voltage ripple as well as lower output voltage drop during load transients.

Note that ceramic capacitors have a DC Bias effect, which will have a strong influence on the final effective capacitance needed. Therefore the right capacitor value has to be chosen very carefully. Package size and voltage rating in combination with material are responsible for differences between the rated capacitor value and the effective capacitance. The minimum effective capacitance value should be $1.2 \mu\text{F}$ but preferred value is about $4.7 \mu\text{F}$

Table 1. Passive Components: Recommended Minimum Effective Values

COMPONENT	MIN	TARGET	MAX	UNIT
C_{IN}	1.2	4.7	6.5	μF
C_{OUT}	1.2	4.7	10	μF
L_{IN}	0.7	1	1.3	μH

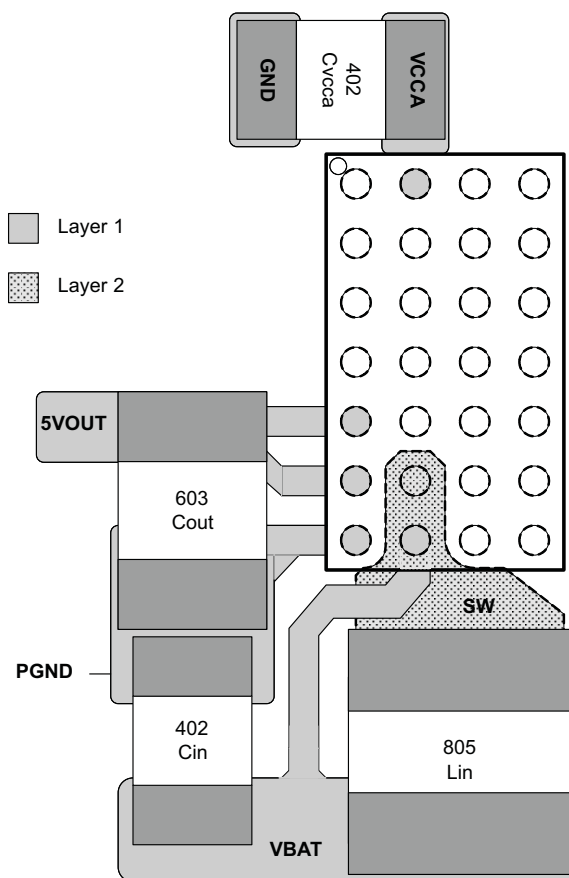

Figure 3. Board Layout (DC-DC Components) (Top View)

List of components:

- L_{IN} = MURATA LQM21PN1R0MC0 or L_{IN} = Toko MDT2010-CN1R0
- C_{IN} = MURATA GRM188R60J225ME19 (2.2 μF , 6.3 V, 0603, X5R) or MURATA GRM188R60J475ME19 (4.7 μF , 6.3 V, 0603, X5R)
- C_{OUT} = MURATA GRM188R60J475ME19 (4.7 μF , 6.3 V, 0603, X5R)
- C_{VCCA} = MURATA GRM155R60J104MA01 (0.1 μF , 6.3 V, 0402, X5R)

TPD12S015 EVM Layout

The TPD12S015 EVM has been designed for HDMI functional testing and includes both HDMI A-type and HDMI C-type connectors. Board jumpers enable and disable the dc-dc and level shifting circuitry. There are two supply terminals (VCCA and VBAT) and one GND terminal at the edge of the board. High speed lines were kept on top and bottom layers and matched for 50 Ω line to GND. All the high speed lines are matched to minimize the skew. The board has three test fixtures for testing the TPD12S015 in the following environments:

- The top segment enables system designers to test the TPD12S015 using the HDMI Class A connector
- The middle segment enables the system designers to test to test the TPD12S015 using the HDMI Class C connector
- The bottom segment enables the system designers to test signal integrity and eye pattern using differential

[查询TPD12S015 供应商](#)

probe.

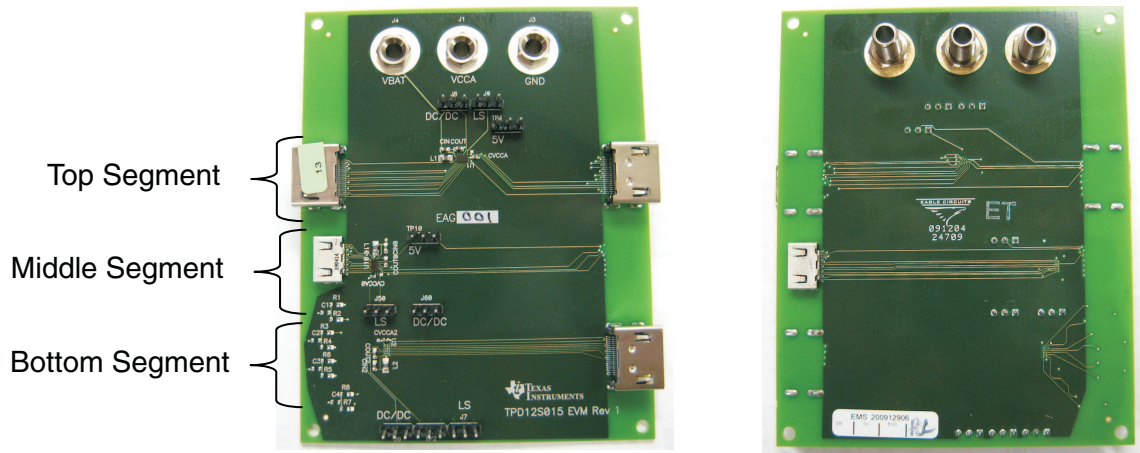

Figure 4. TPD12S015 EVM Top and Bottom View

The EVM board has 6 layers. The signal stack up is described below:

BOARD LAYER	DESCRIPTION
Layer 1	High-speed signal layer
Layer 2	Ground plane
Layer 3	Control signal layer
Layer 4	Control signal layer
Layer 5	Power plane
Layer 6	High-speed signal layer

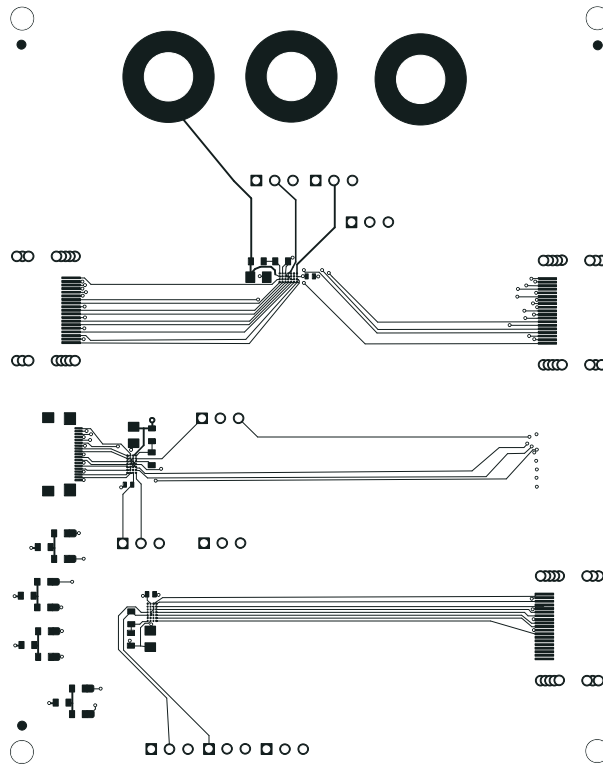

Figure 5. Layer 1: High-Speed Signal layer

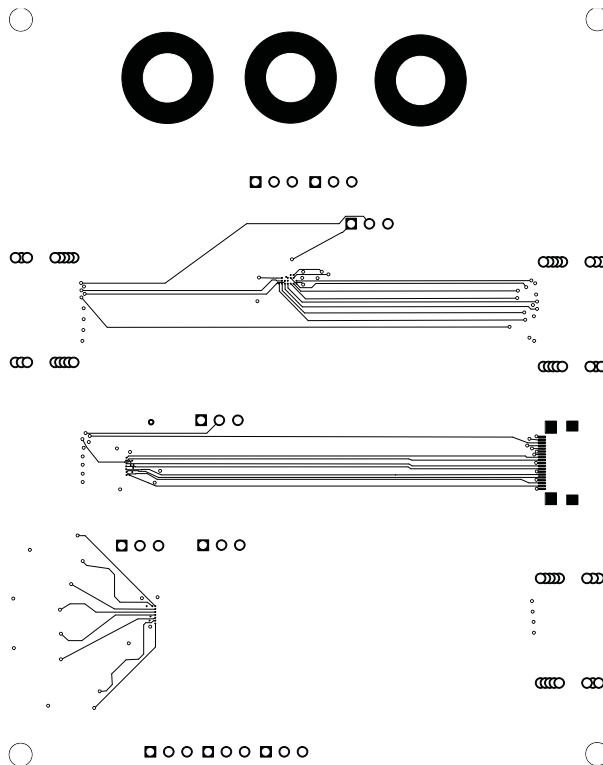

Figure 6. Layer 6: High-Speed Signal layer

[查询TPD12S015 快应商](#)

TYPICAL CHARACTERISTICS

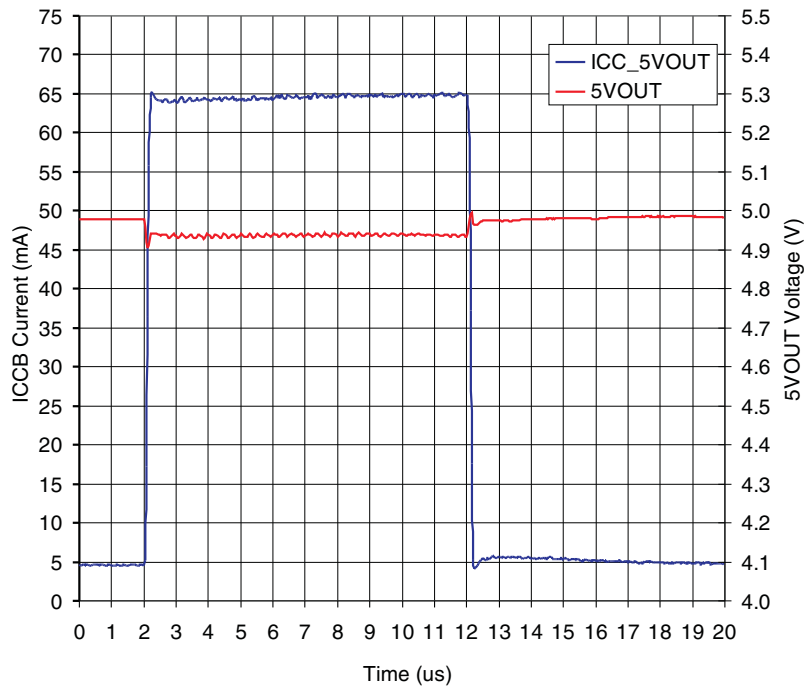

Figure 7. Load Transient Response

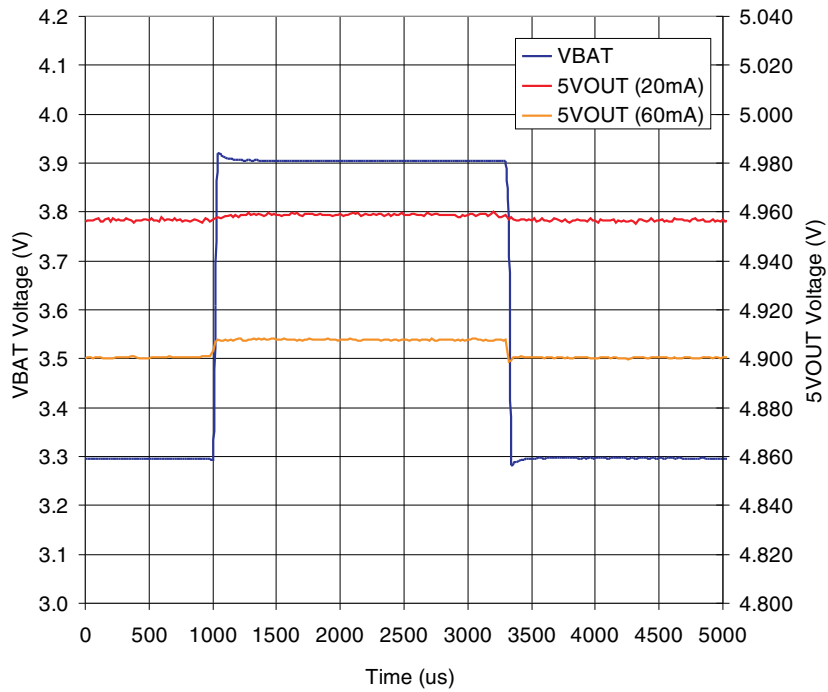
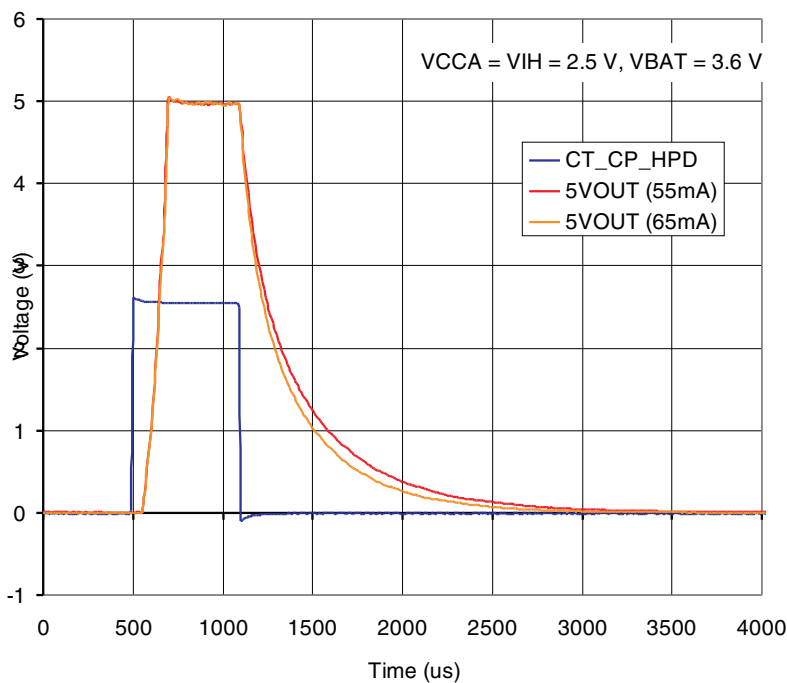
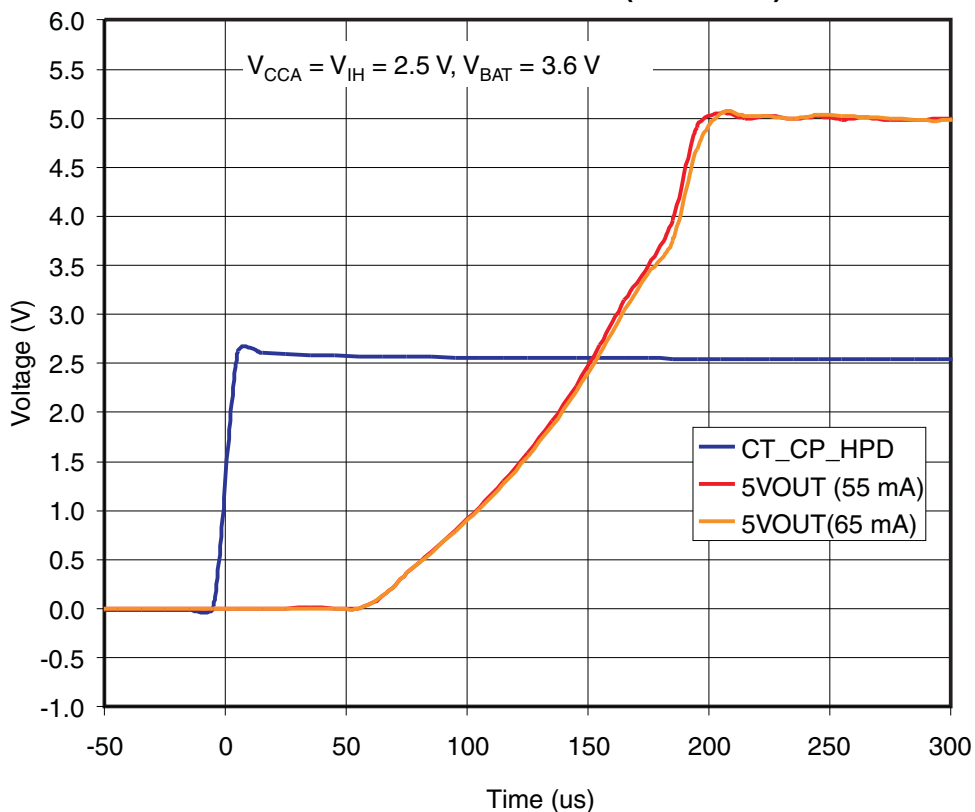

Figure 8. Line Transient Response

TYPICAL CHARACTERISTICS (continued)



[查询TPD12S015 供应商](#)

TYPICAL CHARACTERISTICS (continued)

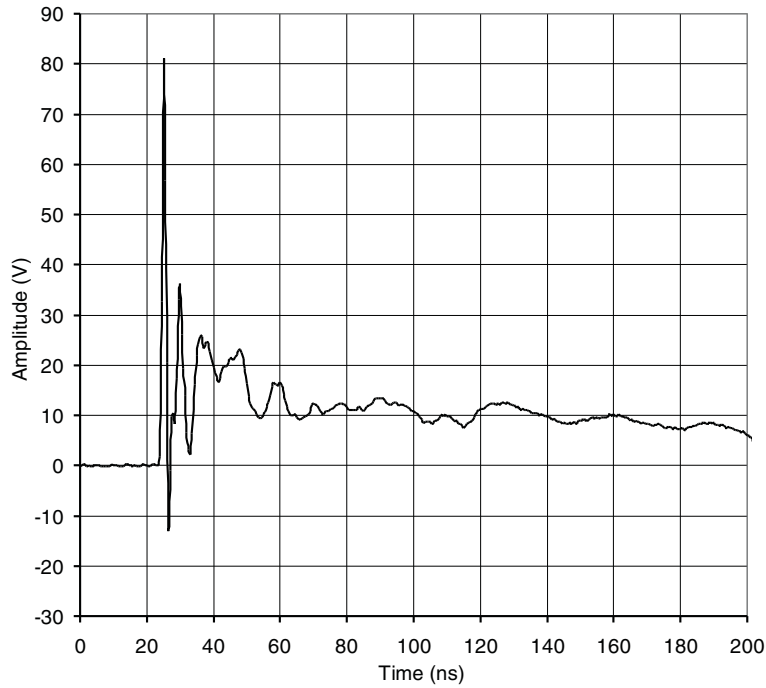

Figure 11. IEC Clamping Waveforms 8 kV Contact (IEC ESD Pins)

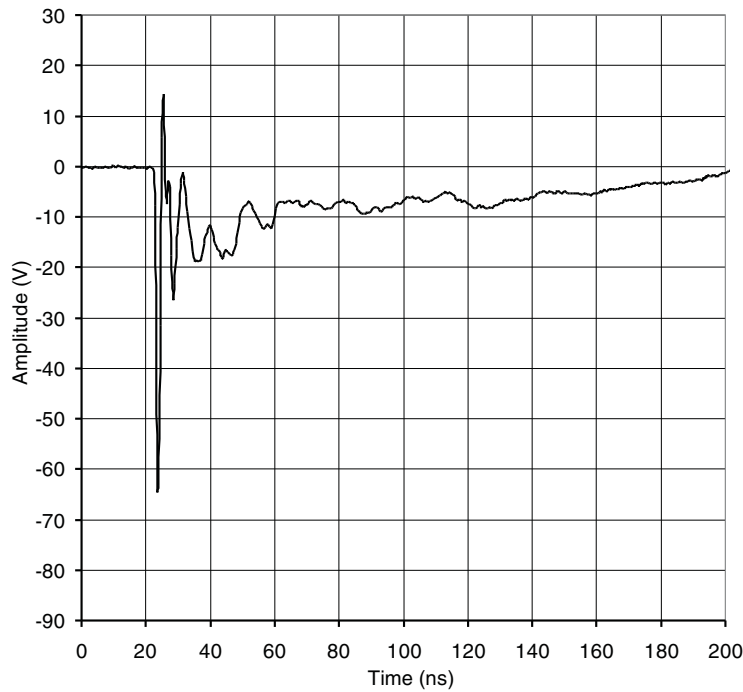

Figure 12. IEC Clamping Waveforms -8 kV Contact (IEC ESD Pins)

TYPICAL CHARACTERISTICS (continued)

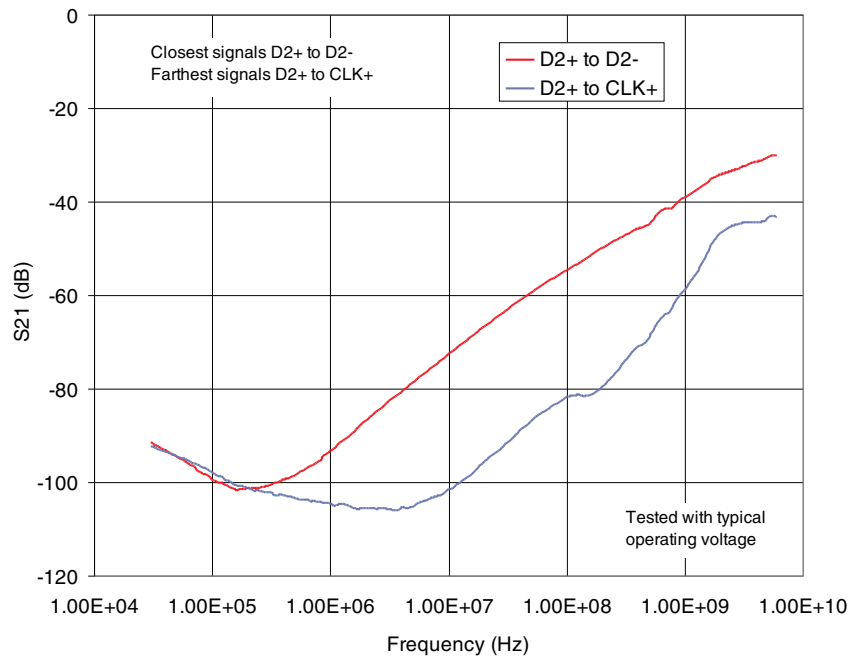

Figure 13. Channel-to-Channel Crosstalk

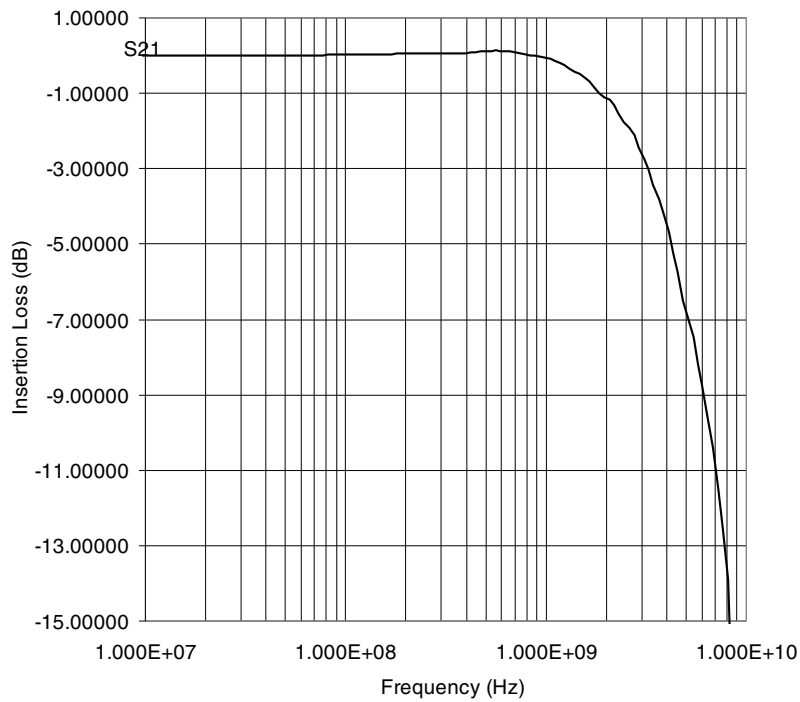

Figure 14. Insertion Loss Data Line to GND

[查询TPD12S015 供应商](#)

TYPICAL CHARACTERISTICS (continued)

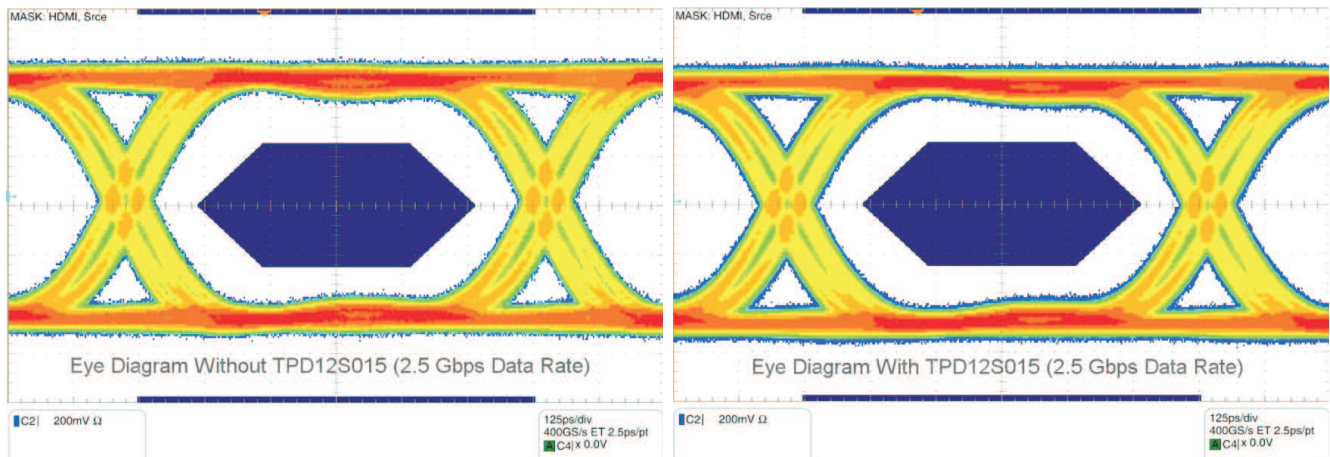

Figure 15. Eye Diagram Performance on a Test Board for the D+, D- Lines at 2.5 Gbps

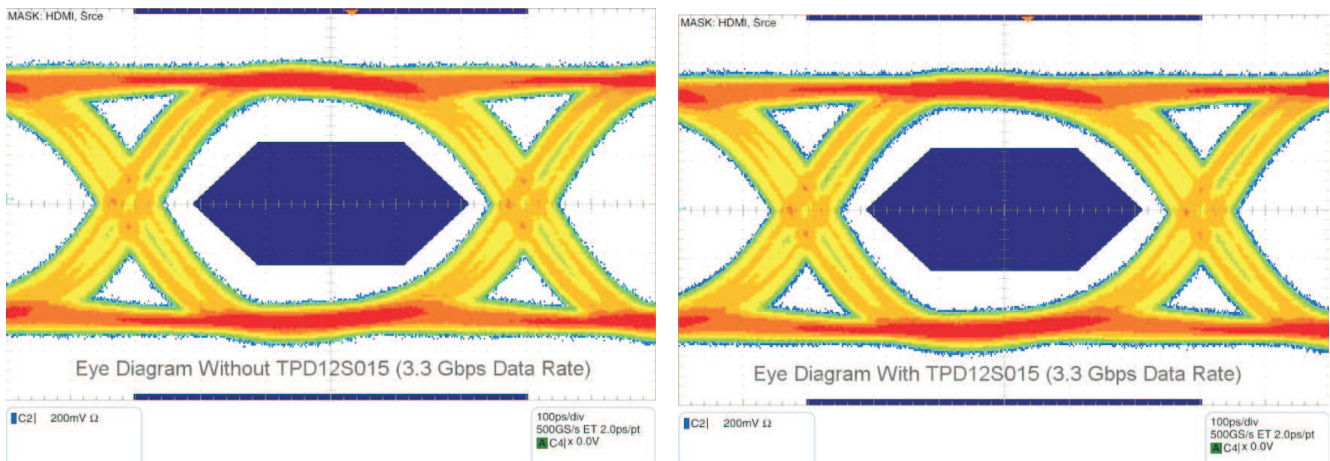
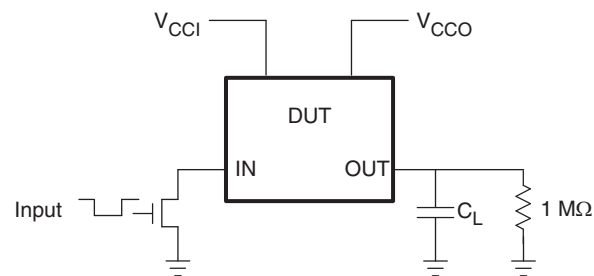
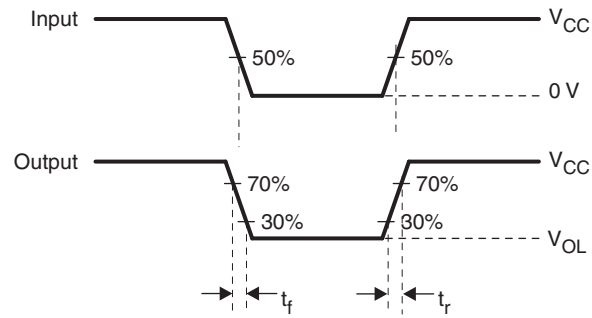

Figure 16. Eye Diagram Performance on a Test Board for the D+, D- Lines at 3.3 Gbps

PARAMETER MEASUREMENT INFORMATION



PIN	C _L
DDC, CEC (A side)	750 pF
DDC, CEC, HPD (B side)	15 pF



- A. R_T termination resistance should be equal to Z_{OUT} of pulse generators.
- B. C_L includes probe and jig capacitance.
- C. All input pulses are supplied by generators having the following characteristics: $PRR \leq 10$ MHz, $Z_O = 50 \Omega$, slew rate ≥ 1 V/ns.
- D. The outputs are measured one at a time, with one transition per measurement.
- E. t_{PLH} and t_{PHL} are the same as t_{pd} .

Figure 17. Test Circuit and Voltage Waveforms

[查询TPD12S015 供应商](#)

REVISION HISTORY

Changes from Revision B (July 2010) to Revision C	Page
• Added Type D connector specification to "FEATURES"	1
• Added Type D connector specification to "DESCRIPTION/ORDERING INFORMATION"	1
• Deleted obsolete part number TPD12S015YFFRB from ordering information table	2



www.ti.com

PACKAG

PACKAGING INFORMATION

Orderable Device	Status ⁽¹⁾	Package Type	Package Drawing	Pins	Package Qty	Eco Plan ⁽²⁾	Lead/Ball Finish	MSL Peak Temp ⁽³⁾
TPD12S015YFFR	ACTIVE	DSBGA	YFF	28	3000	Green (RoHS & no Sb/Br)	SNAGCU	Level-1-260C

⁽¹⁾ The marketing status values are defined as follows:

ACTIVE: Product device recommended for new designs.

LIFEBUY: TI has announced that the device will be discontinued, and a lifetime-buy period is in effect.

NRND: Not recommended for new designs. Device is in production to support existing customers, but TI does not recommend using this part in a new design.

PREVIEW: Device has been announced but is not in production. Samples may or may not be available.

OBSOLETE: TI has discontinued the production of the device.

⁽²⁾ Eco Plan - The planned eco-friendly classification: Pb-Free (RoHS), Pb-Free (RoHS Exempt), or Green (RoHS & no Sb/Br) - please check <http://www.ti.com> for more information and additional product content details.

TBD: The Pb-Free/Green conversion plan has not been defined.

Pb-Free (RoHS): TI's terms "Lead-Free" or "Pb-Free" mean semiconductor products that are compatible with the current RoHS requirements for all RoHS materials, with the exception of lead not exceed 0.1% by weight in homogeneous materials. Where designed to be soldered at high temperatures, TI Pb-Free products are suitable for use in high temperature applications.

Pb-Free (RoHS Exempt): This component has a RoHS exemption for either 1) lead-based flip-chip solder bumps used between the die and package, or 2) lead-based eutectic solder used between the leadframe and die. The component is otherwise considered Pb-Free (RoHS compatible) as defined above.

Green (RoHS & no Sb/Br): TI defines "Green" to mean Pb-Free (RoHS compatible), and free of Bromine (Br) and Antimony (Sb) based flame retardants (both of which are RoHS prohibited materials) in homogeneous material.

⁽³⁾ MSL, Peak Temp. -- The Moisture Sensitivity Level rating according to the JEDEC industry standard classifications, and peak solder temperature.

Important Information and Disclaimer: The information provided on this page represents TI's knowledge and belief as of the date that it is provided. TI disclaims any warranty, expressed or implied, for the information provided by third parties, and makes no representation or warranty as to the accuracy of such information. Efforts are underway to better integrate information from third parties into TI's data sheets and Datasheets. TI continues to take reasonable steps to provide representative and accurate information but may not have conducted destructive testing or chemical analysis on all TI and TI suppliers consider certain information to be proprietary, and thus CAS numbers and other limited information may not be available for release. TI is not responsible for any errors or omissions in this information.

In no event shall TI's liability arising out of such information exceed the total purchase price of the TI part(s) at issue in this document sold by TI to Customer.

TAPE AND REEL INFORMATION



QUADRANT ASSIGNMENTS FOR PIN 1 ORIENTATION IN TAPE



*All dimensions are nominal

Device	Package Type	Package Drawing	Pins	SPQ	Reel Diameter (mm)	Reel Width W1 (mm)	A0 (mm)	B0 (mm)	K0 (mm)	P1 (mm)	W (mm)	Pin1 Quadrant
TPD12S015YFFR	DSBGA	YFF	28	3000	180.0	8.4	1.73	2.93	0.81	4.0	8.0	Q1

TAPE AND REEL BOX DIMENSIONS



*All dimensions are nominal

Device	Package Type	Package Drawing	Pins	SPQ	Length (mm)	Width (mm)	Height (mm)
TPD12S015YFFR	DSBGA	YFF	28	3000	190.5	212.7	31.8

[查询"TPD12S015"供应商](#)

YFF (R-XBGA-N28)

DIE-SIZE BALL GRID ARRAY

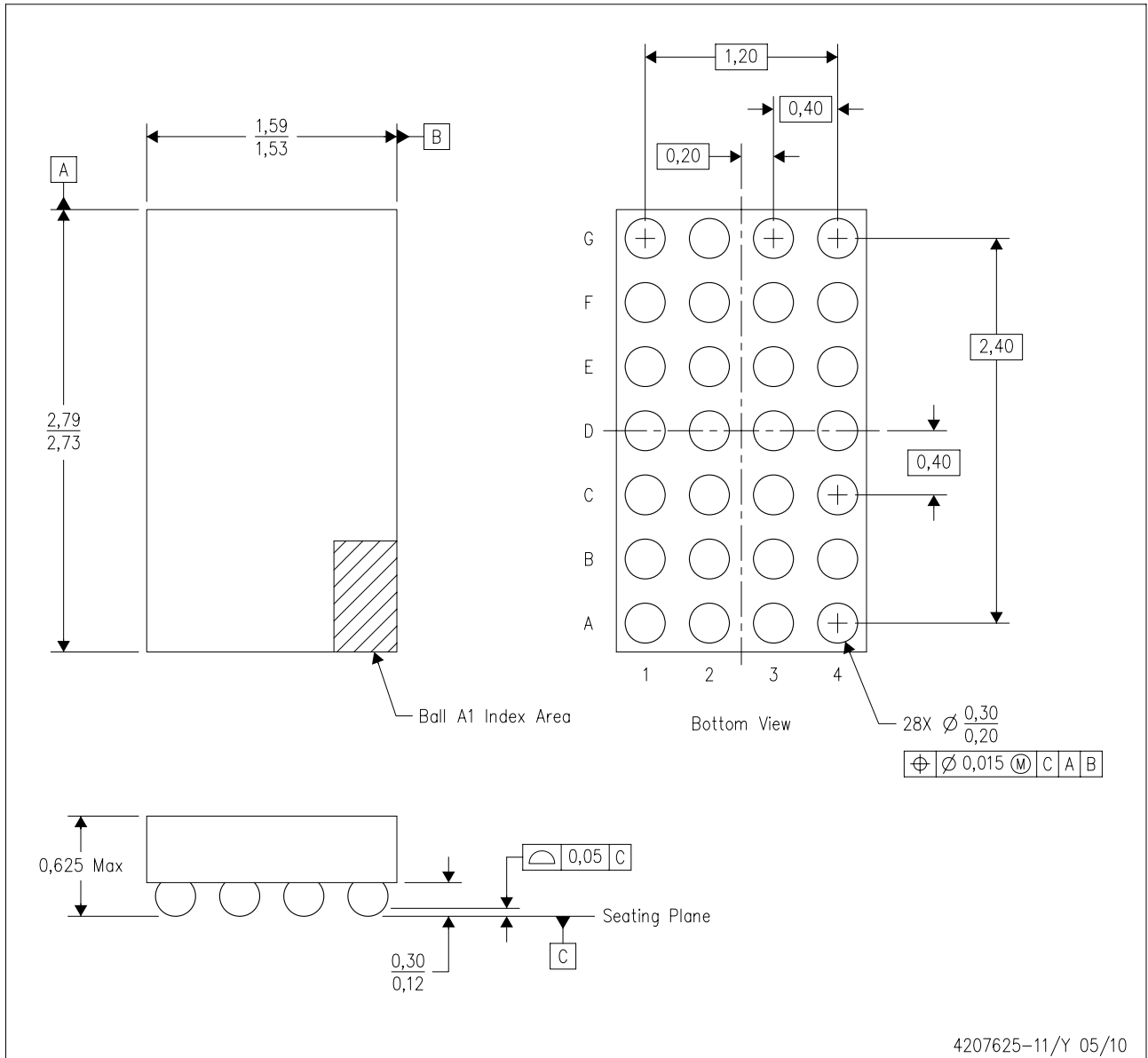

- NOTES:
- A. All linear dimensions are in millimeters. Dimensioning and tolerancing per ASME Y14.5M-1994.
 - B. This drawing is subject to change without notice.
 - C. NanoFree™ package configuration.
 - D. This package contains Pb-free balls.

NanoFree is a trademark of Texas Instruments.

[查询"TPD12S015"供应商](#)

IMPORTANT NOTICE

Texas Instruments Incorporated and its subsidiaries (TI) reserve the right to make corrections, modifications, enhancements, improvements, and other changes to its products and services at any time and to discontinue any product or service without notice. Customers should obtain the latest relevant information before placing orders and should verify that such information is current and complete. All products are sold subject to TI's terms and conditions of sale supplied at the time of order acknowledgment.

TI warrants performance of its hardware products to the specifications applicable at the time of sale in accordance with TI's standard warranty. Testing and other quality control techniques are used to the extent TI deems necessary to support this warranty. Except where mandated by government requirements, testing of all parameters of each product is not necessarily performed.

TI assumes no liability for applications assistance or customer product design. Customers are responsible for their products and applications using TI components. To minimize the risks associated with customer products and applications, customers should provide adequate design and operating safeguards.

TI does not warrant or represent that any license, either express or implied, is granted under any TI patent right, copyright, mask work right, or other TI intellectual property right relating to any combination, machine, or process in which TI products or services are used. Information published by TI regarding third-party products or services does not constitute a license from TI to use such products or services or a warranty or endorsement thereof. Use of such information may require a license from a third party under the patents or other intellectual property of the third party, or a license from TI under the patents or other intellectual property of TI.

Reproduction of TI information in TI data books or data sheets is permissible only if reproduction is without alteration and is accompanied by all associated warranties, conditions, limitations, and notices. Reproduction of this information with alteration is an unfair and deceptive business practice. TI is not responsible or liable for such altered documentation. Information of third parties may be subject to additional restrictions.

Resale of TI products or services with statements different from or beyond the parameters stated by TI for that product or service voids all express and any implied warranties for the associated TI product or service and is an unfair and deceptive business practice. TI is not responsible or liable for any such statements.

TI products are not authorized for use in safety-critical applications (such as life support) where a failure of the TI product would reasonably be expected to cause severe personal injury or death, unless officers of the parties have executed an agreement specifically governing such use. Buyers represent that they have all necessary expertise in the safety and regulatory ramifications of their applications, and acknowledge and agree that they are solely responsible for all legal, regulatory and safety-related requirements concerning their products and any use of TI products in such safety-critical applications, notwithstanding any applications-related information or support that may be provided by TI. Further, Buyers must fully indemnify TI and its representatives against any damages arising out of the use of TI products in such safety-critical applications.

TI products are neither designed nor intended for use in military/aerospace applications or environments unless the TI products are specifically designated by TI as military-grade or "enhanced plastic." Only products designated by TI as military-grade meet military specifications. Buyers acknowledge and agree that any such use of TI products which TI has not designated as military-grade is solely at the Buyer's risk, and that they are solely responsible for compliance with all legal and regulatory requirements in connection with such use.

TI products are neither designed nor intended for use in automotive applications or environments unless the specific TI products are designated by TI as compliant with ISO/TS 16949 requirements. Buyers acknowledge and agree that, if they use any non-designated products in automotive applications, TI will not be responsible for any failure to meet such requirements.

Following are URLs where you can obtain information on other Texas Instruments products and application solutions:

Products		Applications	
Amplifiers	amplifier.ti.com	Audio	www.ti.com/audio
Data Converters	dataconverter.ti.com	Automotive	www.ti.com/automotive
DLP® Products	www.dlp.com	Communications and Telecom	www.ti.com/communications
DSP	dsp.ti.com	Computers and Peripherals	www.ti.com/computers
Clocks and Timers	www.ti.com/clocks	Consumer Electronics	www.ti.com/consumer-apps
Interface	interface.ti.com	Energy	www.ti.com/energy
Logic	logic.ti.com	Industrial	www.ti.com/industrial
Power Mgmt	power.ti.com	Medical	www.ti.com/medical
Microcontrollers	microcontroller.ti.com	Security	www.ti.com/security
RFID	www.ti-rfid.com	Space, Avionics & Defense	www.ti.com/space-avionics-defense
RF/IF and ZigBee® Solutions	www.ti.com/lprf	Video and Imaging	www.ti.com/video
		Wireless	www.ti.com/wireless-apps

Mailing Address: Texas Instruments, Post Office Box 655303, Dallas, Texas 75265
Copyright © 2010, Texas Instruments Incorporated