



March 1998

# 100328 Low Power Octal ECL/TTL Bi-Directional Translator with Latch

## General Description

The 100328 is an octal latched bi-directional translator designed to convert TTL logic levels to 100K ECL logic levels and vice versa. The direction of this translation is determined by the DIR input. A LOW on the output enable input (OE) holds the ECL outputs in a cut-off state and the TTL outputs at a high impedance level. A HIGH on the latch enable input (LE) latches the data at both inputs even though only one output is enabled at the time. A LOW on LE makes the 100328 transparent.

The cut-off state is designed to be more negative than a normal ECL LOW level. This allows the output emitter-followers to turn off when the termination supply is  $-2.0V$ , presenting a high impedance to the data bus. This high impedance reduces termination power and prevents loss of low state noise margin when several loads share the bus.

The 100328 is designed with FAST<sup>®</sup> TTL output buffers, featuring optimal DC drive and capable of quickly charging and discharging highly capacitive loads. All inputs have 50 k $\Omega$  pull-down resistors.

## Features

- Identical performance to the 100128 at 50% of the supply current
- Bi-directional translation
- 2000V ESD protection
- Latched outputs
- FAST TTL outputs
- 3-STATE outputs
- Voltage compensated operating range =  $-4.2V$  to  $-5.7V$
- Available to industrial grade temperature range
- Available to MIL-STD-883

## Ordering Code:

## Logic Symbol

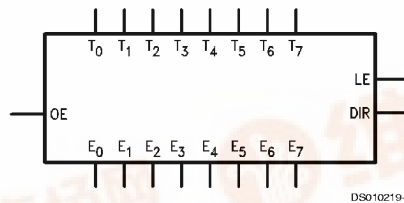

| Pin Names                      | Description             |
|--------------------------------|-------------------------|
| E <sub>0</sub> -E <sub>7</sub> | ECL Data I/O            |
| T <sub>0</sub> -T <sub>7</sub> | TTL Data I/O            |
| OE                             | Output Enable Input     |
| LE                             | Latch Enable Input      |
| DIR                            | Direction Control Input |

All pins function at 100K ECL levels except for T<sub>0</sub>-T<sub>7</sub>.

FAST<sup>®</sup> is a registered trademark of Fairchild Semiconductor Corporation.

100328 Low Power Octal ECL/TTL Bi-Directional Translator with Latch



### Connection Diagrams

**24-Pin DIP/SOIC**

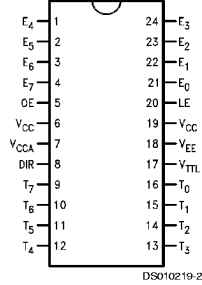

**28-Pin PCC**

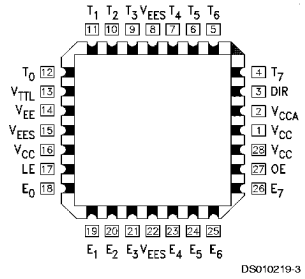

**24-Pin Quad Cerpak**

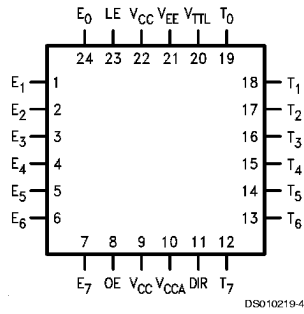

### Functional Diagram

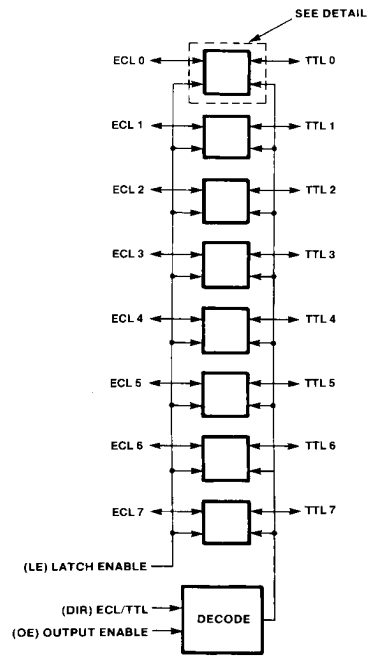

DS010219-5

Note: LE, DIR, and OE use ECL logic levels

### Truth Table

| OE | DIR | LE | ECL Port      | TTL Port | Notes        |
|----|-----|----|---------------|----------|--------------|
| L  | X   | L  | LOW (Cut-Off) | Z        |              |
| L  | L   | H  | Input         | Z        | (Notes 1, 3) |
| L  | H   | H  | LOW (Cut-Off) | Input    | (Notes 2, 3) |
| H  | L   | L  | L             | L        | (Notes 1, 4) |
| H  | L   | L  | H             | H        | (Notes 1, 4) |
| H  | L   | H  | X             | Latched  | (Notes 1, 3) |
| H  | H   | L  | L             | L        | (Notes 2, 4) |
| H  | H   | L  | H             | H        | (Notes 2, 4) |
| H  | H   | H  | Latched       | X        | (Notes 2, 4) |

H = HIGH Voltage Level  
 L = LOW Voltage Level  
 X = Don't Care  
 Z = High Impedance

Note 1: ECL input to TTL output mode.

Note 2: TTL input to ECL output mode.

Note 3: Retains data present before LE set HIGH.

Note 4: Latch is transparent.

### Detail

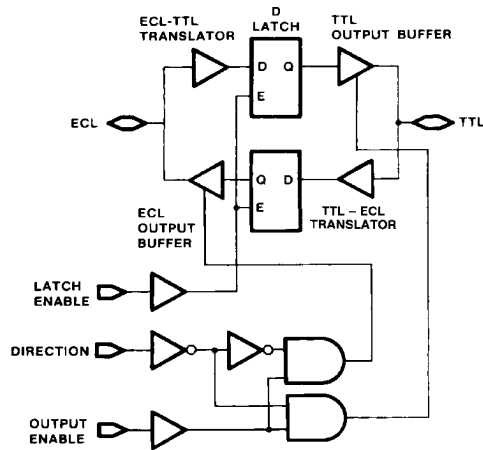

DS010219-6

| <b>Absolute Maximum Ratings</b> (Note 5) |                   | Output in LOW State (Max) ESD (Note 6) |  | Twice the Rated $I_{OL}$ (mA) $\geq 2000V$ |  |
|------------------------------------------|-------------------|----------------------------------------|--|--------------------------------------------|--|
| Storage Temperature ( $T_{STG}$ )        | -65°C to +150°C   |                                        |  |                                            |  |
| Maximum Junction Temperature ( $T_J$ )   |                   |                                        |  |                                            |  |
| Ceramic                                  | +175°C            |                                        |  |                                            |  |
| Plastic                                  | +150°C            |                                        |  |                                            |  |
| $V_{EE}$ Pin Potential to Ground Pin     | -7.0V to +0.5V    |                                        |  |                                            |  |
| $V_{TTL}$ Pin Potential to Ground Pin    | -0.5V to +6.0V    |                                        |  |                                            |  |
| ECL Input Voltage (DC)                   | $V_{EE}$ to +0.5V |                                        |  |                                            |  |
| ECL Output Current (DC Output HIGH)      | -50 mA            |                                        |  |                                            |  |
| TTL Input Voltage (Note 7)               | -0.5V to +6.0V    |                                        |  |                                            |  |
| TTL Input Current (Note 7)               | -30 mA to +5.0 mA |                                        |  |                                            |  |
| Voltage Applied to Output in HIGH State  |                   |                                        |  |                                            |  |
| 3-STATE Output Current Applied to TTL    | -0.5V to +5.5V    |                                        |  |                                            |  |

| <b>Recommended Operating Conditions</b> |                 |
|-----------------------------------------|-----------------|
| Case Temperature ( $T_C$ )              |                 |
| Commercial                              | 0°C to +85°C    |
| Industrial                              | -40°C to +85°C  |
| Military                                | -55°C to +125°C |
| ECL Supply Voltage ( $V_{EE}$ )         | -5.7V to -4.2V  |
| TTL Supply Voltage ( $V_{TTL}$ )        | +4.5V to +5.5V  |

**Note 5:** Absolute maximum ratings are those values beyond which the device may be damaged or have its useful life impaired. Functional operation under these conditions is not implied.

**Note 6:** ESD testing conforms to MIL-STD-883, Method 3015.

**Note 7:** Either voltage limit or current limit is sufficient to protect inputs.

### Commercial Version TTL-to-ECL DC Electrical Characteristics

$V_{EE} = -4.2V$  to  $-5.7V$ ,  $V_{CC} = V_{CCA} = GND$ ,  $T_C = 0^\circ C$  to  $+85^\circ C$ ,  $V_{TTL} = +4.5V$  to  $+5.5V$  (Note 8)

| Symbol    | Parameter                             | Min   | Typ   | Max   | Units | Conditions                                                                       |
|-----------|---------------------------------------|-------|-------|-------|-------|----------------------------------------------------------------------------------|
| $V_{OH}$  | Output HIGH Voltage                   | -1025 | -955  | -870  | mV    | $V_{IN} = V_{IH(Max)}$ or $V_{IL(Min)}$                                          |
| $V_{OL}$  | Output LOW Voltage                    | -1830 | -1705 | -1620 | mV    | Loading with 50Ω to -2V                                                          |
|           | Cutoff Voltage                        |       | -2000 | -1950 | mV    | OE or DIR Low, $V_{IN} = V_{IH(Max)}$ or $V_{IL(Min)}$ , Loading with 50Ω to -2V |
| $V_{OHC}$ | Output HIGH Voltage Corner Point High | -1035 |       |       | mV    | $V_{IN} = V_{IH(Min)}$ or $V_{IL(Max)}$<br>Loading with 50Ω to -2V               |
| $V_{OLC}$ | Output LOW Voltage Corner Point Low   |       |       | -1610 | mV    |                                                                                  |
| $V_{IH}$  | Input HIGH Voltage                    | 2.0   |       | 5.0   | V     | Over $V_{TTL}$ , $V_{EE}$ , $T_C$ Range                                          |
| $V_{IL}$  | Input LOW Voltage                     | 0     |       | 0.8   | V     | Over $V_{TTL}$ , $V_{EE}$ , $T_C$ Range                                          |
| $I_{IH}$  | Input HIGH Current                    |       |       | 70    | μA    | $V_{IN} = +2.7V$                                                                 |
|           | Breakdown Test                        |       |       | 1.0   | mA    | $V_{IN} = +5.5V$                                                                 |
| $I_{IL}$  | Input LOW Current                     | -700  |       |       | μA    | $V_{IN} = +0.5V$                                                                 |
| $V_{FCD}$ | Input Clamp Diode Voltage             | -1.2  |       |       | V     | $I_{IN} = -18 mA$                                                                |
| $I_{EE}$  | $V_{EE}$ Supply Current               |       |       |       | mA    | LE Low, OE and DIR High<br>Inputs Open                                           |
|           |                                       | -159  |       | -75   |       | $V_{EE} = -4.2V$ to $-4.8V$                                                      |
|           |                                       | -169  |       | -75   |       | $V_{EE} = -4.2V$ to $-5.7V$                                                      |

**Note 8:** The specified limits represent the "worst case" value for the parameter. Since these values normally occur at the temperature extremes, additional noise immunity and guardbanding can be achieved by decreasing the allowable system operating ranges. Conditions for testing shown in the tables are chosen to guarantee operation under "worst case" conditions.

### Commercial Version ECL-to-TTL DC Electrical Characteristics

$V_{EE} = -4.2V$  to  $-5.7V$ ,  $V_{CC} = V_{CCA} = GND$ ,  $T_C = 0^\circ C$  to  $+85^\circ C$ ,  $C_L = 50 pF$ ,  $V_{TTL} = +4.5V$  to  $+5.5V$  (Note 9)

| Symbol   | Parameter           | Min | Typ | Max | Units | Conditions                           |
|----------|---------------------|-----|-----|-----|-------|--------------------------------------|
| $V_{OH}$ | Output HIGH Voltage | 2.7 | 3.1 |     | V     | $I_{OH} = -3 mA$ , $V_{TTL} = 4.75V$ |
|          |                     | 2.4 | 2.9 |     | V     | $I_{OH} = -3 mA$ , $V_{TTL} = 4.50V$ |

**Commercial Version  
ECL-to-TTL DC Electrical Characteristics** (Continued)

$V_{EE} = -4.2V$  to  $-5.7V$ ,  $V_{CC} = V_{CCA} = GND$ ,  $T_C = 0^\circ C$  to  $+85^\circ C$ ,  $C_L = 50$  pF,  $V_{TTL} = +4.5V$  to  $+5.5V$  (Note 9)

| Symbol     | Parameter                       | Min   | Typ | Max            | Units   | Conditions                                                    |
|------------|---------------------------------|-------|-----|----------------|---------|---------------------------------------------------------------|
| $V_{OL}$   | Output LOW Voltage              |       | 0.3 | 0.5            | V       | $I_{OL} = 24$ mA, $V_{TTL} = 4.50V$                           |
| $V_{IH}$   | Input HIGH Voltage              | -1165 |     | -870           | mV      | Guaranteed HIGH Signal for All Inputs                         |
| $V_{IL}$   | Input LOW Voltage               | -1830 |     | -1475          | mV      | Guaranteed LOW Signal for All Inputs                          |
| $I_{IH}$   | Input HIGH Current              |       |     | 350            | $\mu A$ | $V_{IN} = V_{IH}$ (Max)                                       |
| $I_{IL}$   | Input LOW Current               | 0.50  |     |                | $\mu A$ | $V_{IN} = V_{IL}$ (Min)                                       |
| $I_{OZHT}$ | 3-STATE Current<br>Output High  |       |     | 70             | $\mu A$ | $V_{OUT} = +2.7V$                                             |
| $I_{OZLT}$ | 3-STATE Current<br>Output Low   | -700  |     |                | $\mu A$ | $V_{OUT} = +0.5V$                                             |
| $I_{OS}$   | Output Short-Circuit<br>Current | -150  |     | -60            | mA      | $V_{OUT} = 0.0V$ , $V_{TTL} = +5.5V$                          |
| $I_{TTL}$  | $V_{TTL}$ Supply Current        |       |     | 74<br>49<br>67 | mA      | TTL Outputs LOW<br>TTL Outputs HIGH<br>TTL Outputs in 3-STATE |

**Commercial Version  
DIP TTL-to-ECL AC Electrical Characteristics**

$V_{EE} = -4.2V$  to  $-5.7V$ ,  $V_{TTL} = +4.5V$  to  $+5.5V$ ,  $V_{CC} = V_{CCA} = GND$  (Note 9)

| Symbol                 | Parameter                                 | $T_C = 0^\circ C$ |     | $T_C = 25^\circ C$ |     | $T_C = 85^\circ C$ |     | Units | Conditions   |
|------------------------|-------------------------------------------|-------------------|-----|--------------------|-----|--------------------|-----|-------|--------------|
|                        |                                           | Min               | Max | Min                | Max | Min                | Max |       |              |
| $t_{PLH}$<br>$t_{PHL}$ | $T_n$ to $E_n$<br>(Transparent)           | 1.1               | 3.5 | 1.1                | 3.6 | 1.1                | 3.8 | ns    | Figures 1, 2 |
| $t_{PLH}$<br>$t_{PHL}$ | LE to $E_n$                               | 1.7               | 3.6 | 1.7                | 3.7 | 1.9                | 3.9 | ns    | Figures 1, 2 |
| $t_{pZH}$              | OE to $E_n$<br>(Cutoff to High)           | 1.3               | 4.2 | 1.5                | 4.4 | 1.7                | 4.8 | ns    | Figures 1, 2 |
| $t_{pHZ}$              | OE to $E_n$<br>(High to Cutoff)           | 1.5               | 4.5 | 1.6                | 4.5 | 1.6                | 4.6 | ns    | Figures 1, 2 |
| $t_{pHZ}$              | DIR to $E_n$<br>(High to Cutoff)          | 1.6               | 4.3 | 1.6                | 4.3 | 1.7                | 4.5 | ns    | Figures 1, 2 |
| $t_{set}$              | $T_n$ to LE                               | 1.1               |     | 1.1                |     | 1.1                |     | ns    | Figures 1, 2 |
| $t_{hold}$             | $T_n$ to LE                               | 1.1               |     | 1.1                |     | 1.1                |     | ns    | Figures 1, 2 |
| $t_{pw(H)}$            | Pulse Width LE                            | 2.1               |     | 2.1                |     | 2.1                |     | ns    | Figures 1, 2 |
| $t_{TLH}$<br>$t_{THL}$ | Transition Time<br>20% to 80%, 80% to 20% | 0.6               | 1.6 | 0.6                | 1.6 | 0.6                | 1.6 | ns    | Figures 1, 2 |

**Note 9:** The specified limits represent the "worst" case value for the parameter. Since these values normally occur at the temperature extremes, additional noise immunity and guardbanding can be achieved by decreasing the allowable system operating ranges. Conditions for testing shown in the tables are chosen to guarantee operation under "worst case" conditions.

**Commercial Version  
DIP ECL-to-TTL AC Electrical Characteristics**

$V_{EE} = -4.2V$  to  $-5.7V$ ,  $V_{TTL} = +4.5V$  to  $+5.5V$ ,  $V_{CC} = V_{CCA} = GND$ ,  $C_L = 50$  pF

| Symbol                 | Parameter                       | $T_C = 0^\circ C$ |     | $T_C = 25^\circ C$ |     | $T_C = 85^\circ C$ |     | Units | Conditions   |
|------------------------|---------------------------------|-------------------|-----|--------------------|-----|--------------------|-----|-------|--------------|
|                        |                                 | Min               | Max | Min                | Max | Min                | Max |       |              |
| $t_{PLH}$<br>$t_{PHL}$ | $E_n$ to $T_n$<br>(Transparent) | 2.3               | 5.6 | 2.4                | 5.6 | 2.6                | 5.9 | ns    | Figures 3, 4 |

| Commercial Version<br>DIP ECL-to-TTL AC Electrical Characteristics (Continued)                        |                                |                   |      |                    |      |                    |      |       |              |
|-------------------------------------------------------------------------------------------------------|--------------------------------|-------------------|------|--------------------|------|--------------------|------|-------|--------------|
| $V_{EE} = -4.2V$ to $-5.7V$ , $V_{TTL} = +4.5V$ to $+5.5V$ , $V_{CC} = V_{CCA} = GND$ , $C_L = 50$ pF |                                |                   |      |                    |      |                    |      |       |              |
| Symbol                                                                                                | Parameter                      | $T_C = 0^\circ C$ |      | $T_C = 25^\circ C$ |      | $T_C = 85^\circ C$ |      | Units | Conditions   |
|                                                                                                       |                                | Min               | Max  | Min                | Max  | Min                | Max  |       |              |
| $t_{PLH}$<br>$t_{PHL}$                                                                                | LE to $T_n$                    | 3.1               | 7.2  | 3.1                | 7.2  | 3.3                | 7.7  | ns    | Figures 3, 4 |
| $t_{PZH}$<br>$t_{PZL}$                                                                                | OE to $T_n$<br>(Enable Time)   | 3.4               | 8.45 | 3.7                | 8.95 | 4.0                | 9.7  | ns    | Figures 3, 5 |
| $t_{PHZ}$<br>$t_{PLZ}$                                                                                | OE to $T_n$<br>(Disable Time)  | 3.2               | 8.95 | 3.3                | 8.95 | 3.5                | 9.2  | ns    | Figures 3, 5 |
| $t_{PHZ}$<br>$t_{PLZ}$                                                                                | DIR to $T_n$<br>(Disable Time) | 2.7               | 8.2  | 2.8                | 8.7  | 3.1                | 8.95 | ns    | Figures 3, 6 |
| $t_{set}$                                                                                             | $E_n$ to LE                    | 1.1               |      | 1.1                |      | 1.1                |      | ns    | Figures 3, 6 |
| $t_{hold}$                                                                                            | $E_n$ to LE                    | 2.1               |      | 2.1                |      | 2.6                |      | ns    | Figures 3, 4 |
| $t_{pw(H)}$                                                                                           | Pulse Width LE                 | 4.1               |      | 4.1                |      | 4.1                |      | ns    | Figures 3, 7 |

| Commercial Version<br>SOIC, PCC and Cerpak TTL-to-ECL AC Electrical Characteristics |                                                                                 |                   |     |                    |     |                    |     |       |                       |
|-------------------------------------------------------------------------------------|---------------------------------------------------------------------------------|-------------------|-----|--------------------|-----|--------------------|-----|-------|-----------------------|
| $V_{EE} = -4.2V$ to $-5.7V$ , $V_{TTL} = +4.5V$ to $+5.5V$                          |                                                                                 |                   |     |                    |     |                    |     |       |                       |
| Symbol                                                                              | Parameter                                                                       | $T_C = 0^\circ C$ |     | $T_C = 25^\circ C$ |     | $T_C = 85^\circ C$ |     | Units | Conditions            |
|                                                                                     |                                                                                 | Min               | Max | Min                | Max | Min                | Max |       |                       |
| $t_{PLH}$<br>$t_{PHL}$                                                              | $T_n$ to $E_n$<br>(Transparent)                                                 | 1.1               | 3.3 | 1.1                | 3.4 | 1.1                | 3.6 | ns    | Figures 1, 2          |
| $t_{PLH}$<br>$t_{PHL}$                                                              | LE to $E_n$                                                                     | 1.7               | 3.4 | 1.7                | 3.5 | 1.9                | 3.7 | ns    | Figures 1, 2          |
| $t_{PZH}$                                                                           | OE to $E_n$<br>(Cutoff to High)                                                 | 1.3               | 4.0 | 1.5                | 4.2 | 1.7                | 4.6 | ns    | Figures 1, 2          |
| $t_{PHZ}$                                                                           | OE to $E_n$<br>(High to Cutoff)                                                 | 1.5               | 4.3 | 1.6                | 4.3 | 1.6                | 4.4 | ns    | Figures 1, 2          |
| $t_{PHZ}$                                                                           | DIR to $E_n$<br>(High to Cutoff)                                                | 1.6               | 4.1 | 1.6                | 4.1 | 1.7                | 4.3 | ns    | Figures 1, 2          |
| $t_{set}$                                                                           | $T_n$ to LE                                                                     | 1.0               |     | 1.0                |     | 1.0                |     | ns    | Figures 1, 2          |
| $t_{hold}$                                                                          | $T_n$ to LE                                                                     | 1.0               |     | 1.0                |     | 1.0                |     | ns    | Figures 1, 2          |
| $t_{pw(H)}$                                                                         | Pulse Width LE                                                                  | 2.0               |     | 2.0                |     | 2.0                |     | ns    | Figures 1, 2          |
| $t_{TLH}$<br>$t_{THL}$                                                              | Transition Time<br>20% to 80%, 80% to 20%                                       | 0.6               | 1.6 | 0.6                | 1.6 | 0.6                | 1.6 | ns    | Figures 1, 2          |
| $t_{OSHL}$                                                                          | Maximum Skew Common Edge<br>Output-to-Output Variation<br>Data to Output Path   |                   | 200 |                    | 200 |                    | 200 | ps    | PCC Only<br>(Note 10) |
| $t_{OSLH}$                                                                          | Maximum Skew Common Edge<br>Output-to-Output Variation<br>Data to Output Path   |                   | 200 |                    | 200 |                    | 200 | ps    | PCC Only<br>(Note 10) |
| $t_{OST}$                                                                           | Maximum Skew Opposite Edge<br>Output-to-Output Variation<br>Data to Output Path |                   | 650 |                    | 650 |                    | 650 | ps    | PCC Only<br>(Note 10) |
| $t_{ps}$                                                                            | Maximum Skew<br>Pin (Signal) Transition Variation<br>Data to Output Path        |                   | 650 |                    | 650 |                    | 650 | ps    | PCC Only<br>(Note 10) |

### Commercial Version

#### SOIC, PCC and Cerpak TTL-to-ECL AC Electrical Characteristics (Continued)

**Note 10:** Output-to-Output Skew is defined as the absolute value of the difference between the actual propagation delay for any outputs within the same packaged device. The specifications apply to any outputs switching in the same direction either HIGH to LOW ( $t_{OSHL}$ ), or LOW to HIGH ( $t_{OSLH}$ ), or in opposite directions both HL and LH ( $t_{OST}$ ). Parameters  $t_{OST}$  and  $t_{ps}$  guaranteed by design.

### Commercial Version

#### SOIC, PCC and Cerpak ECL-to-TTL AC Electrical Characteristics

$V_{EE} = -4.2V$  to  $-5.7V$ ,  $V_{TTL} = +4.5V$  to  $+5.5V$ ,  $C_L = 50$  pF

| Symbol                 | Parameter                                                                       | $T_C = 0^\circ C$ |      | $T_C = 25^\circ C$ |      | $T_C = 85^\circ C$ |      | Units | Conditions            |
|------------------------|---------------------------------------------------------------------------------|-------------------|------|--------------------|------|--------------------|------|-------|-----------------------|
|                        |                                                                                 | Min               | Max  | Min                | Max  | Min                | Max  |       |                       |
| $t_{PLH}$<br>$t_{PHL}$ | $E_n$ to $T_n$<br>(Transparent)                                                 | 2.3               | 5.4  | 2.4                | 5.4  | 2.6                | 5.7  | ns    | Figures 3, 4          |
| $t_{PLH}$<br>$t_{PHL}$ | LE to $T_n$                                                                     | 3.1               | 7.0  | 3.1                | 7.0  | 3.3                | 7.5  | ns    | Figures 3, 4          |
| $t_{PZH}$<br>$t_{PZL}$ | OE to $T_n$<br>(Enable Time)                                                    | 3.4               | 8.25 | 3.7                | 8.75 | 4.0                | 9.5  | ns    | Figures 3, 5          |
| $t_{PHZ}$<br>$t_{PLZ}$ | OE to $T_n$<br>(Disable Time)                                                   | 3.2               | 8.75 | 3.3                | 8.75 | 3.5                | 9.0  | ns    | Figures 3, 5          |
| $t_{PHZ}$<br>$t_{PLZ}$ | DIR to $T_n$<br>(Disable Time)                                                  | 2.7               | 8.0  | 2.8                | 8.5  | 3.1                | 8.75 | ns    | Figures 3, 6          |
| $t_{set}$              | $E_n$ to LE                                                                     | 1.0               |      | 1.0                |      | 1.0                |      | ns    | Figures 3, 4          |
| $t_{hold}$             | $E_n$ to LE                                                                     | 2.0               |      | 2.0                |      | 2.5                |      | ns    | Figures 3, 4          |
| $t_{pw(H)}$            | Pulse Width LE                                                                  | 4.0               |      | 4.0                |      | 4.0                |      | ns    | Figures 3, 4          |
| $t_{OSHL}$             | Maximum Skew Common Edge<br>Output-to-Output Variation<br>Data to Output Path   |                   | 600  |                    | 600  |                    | 600  | ps    | PCC Only<br>(Note 11) |
| $t_{OSLH}$             | Maximum Skew Common Edge<br>Output-to-Output Variation<br>Data to Output Path   |                   | 850  |                    | 850  |                    | 850  | ps    | PCC Only<br>(Note 11) |
| $t_{OST}$              | Maximum Skew Opposite Edge<br>Output-to-Output Variation<br>Data to Output Path |                   | 1350 |                    | 1350 |                    | 1350 | ps    | PCC Only<br>(Note 11) |
| $t_{ps}$               | Maximum Skew<br>Pin (Signal) Transition Variation<br>Data to Output Path        |                   | 950  |                    | 950  |                    | 950  | ps    | PCC Only<br>(Note 11) |

**Note 11:** Output-to-Output Skew is defined as the absolute value of the difference between the actual propagation delay for any outputs within the same packaged device. The specifications apply to any outputs switching in the same direction either HIGH to LOW ( $t_{OSHL}$ ), or LOW to HIGH ( $t_{OSLH}$ ), or in opposite directions both HL and LH ( $t_{OST}$ ). Parameters  $t_{OST}$  and  $t_{ps}$  guaranteed by design.

### Industrial Version

#### PCC TTL-to-ECL DC Electrical Characteristics

$V_{EE} = -4.2V$  to  $-5.7V$ ,  $V_{CC} = V_{CCA} = GND$ ,  $T_C = -40^\circ C$  to  $+85^\circ C$ ,  $V_{TTL} = +4.5V$  to  $+5.5V$  (Note 12)

| Symbol   | Parameter           | $T_C = -40^\circ C$ |       | $T_C = 0^\circ C$ to $+85^\circ C$ |       | Units | Conditions                                                                                      |
|----------|---------------------|---------------------|-------|------------------------------------|-------|-------|-------------------------------------------------------------------------------------------------|
|          |                     | Min                 | Max   | Min                                | Max   |       |                                                                                                 |
| $V_{OH}$ | Output HIGH Voltage | -1085               | -870  | -1025                              | -870  | mV    | $V_{IN} = V_{IH(Max)}$ or $V_{IL(Min)}$                                                         |
| $V_{OL}$ | Output LOW Voltage  | -1830               | -1575 | -1830                              | -1620 | mV    | Loading with $50\Omega$ to $-2V$                                                                |
|          | Cutoff Voltage      |                     | -1900 |                                    | -1950 | mV    | OE or DIR Low,<br>$V_{IN} = V_{IH(Max)}$ or $V_{IL(Min)}$ ,<br>Loading with $50\Omega$ to $-2V$ |

| <b>Industrial Version</b>                                                                                                                |                                          |                      |       |                                      |       |         |                                                                             |
|------------------------------------------------------------------------------------------------------------------------------------------|------------------------------------------|----------------------|-------|--------------------------------------|-------|---------|-----------------------------------------------------------------------------|
| <b>PCC TTL-to-ECL DC Electrical Characteristics</b> (Continued)                                                                          |                                          |                      |       |                                      |       |         |                                                                             |
| $V_{EE} = -4.2V$ to $-5.7V$ , $V_{CC} = V_{CCA} = GND$ , $T_C = -40^{\circ}C$ to $+85^{\circ}C$ , $V_{TTL} = +4.5V$ to $+5.5V$ (Note 12) |                                          |                      |       |                                      |       |         |                                                                             |
| Symbol                                                                                                                                   | Parameter                                | $T_C = -40^{\circ}C$ |       | $T_C = 0^{\circ}C$ to $+85^{\circ}C$ |       | Units   | Conditions                                                                  |
|                                                                                                                                          |                                          | Min                  | Max   | Min                                  | Max   |         |                                                                             |
| $V_{OHC}$                                                                                                                                | Output HIGH Voltage<br>Corner Point High | -1095                |       | -1035                                |       | mV      | $V_{IN} = V_{IH(Min)}$ or $V_{IL(Max)}$<br>Loading with $50\Omega$ to $-2V$ |
| $V_{OLC}$                                                                                                                                | Output LOW Voltage<br>Corner Point Low   |                      | -1565 |                                      | -1610 | mV      |                                                                             |
| $V_{IH}$                                                                                                                                 | Input HIGH Voltage                       | 2.0                  | 5.0   | 2.0                                  | 5.0   | V       | Over $V_{TTL}$ , $V_{EE}$ , $T_C$ Range                                     |
| $V_{IL}$                                                                                                                                 | Input LOW Voltage                        | 0                    | 0.8   | 0                                    | 0.8   | V       | Over $V_{TTL}$ , $V_{EE}$ , $T_C$ Range                                     |
| $I_{IH}$                                                                                                                                 | Input HIGH Current                       |                      | 70    |                                      | 70    | $\mu A$ | $V_{IN} = +2.7V$                                                            |
|                                                                                                                                          | Breakdown Test                           |                      | 1.0   |                                      | 1.0   | mA      | $V_{IN} = +5.5V$                                                            |
| $I_{IL}$                                                                                                                                 | Input LOW Current                        | -700                 |       | -700                                 |       | $\mu A$ | $V_{IN} = +0.5V$                                                            |
| $V_{FCD}$                                                                                                                                | Input Clamp Diode Voltage                | -1.2                 |       | -1.2                                 |       | V       | $I_{IN} = -18 mA$                                                           |
| $I_{EE}$                                                                                                                                 | $V_{EE}$ Supply Current                  |                      |       |                                      |       |         | LE Low, OE and DIR High<br>Inputs Open                                      |
|                                                                                                                                          |                                          | -159                 | -70   | -159                                 | -75   | mA      | $V_{EE} = -4.2V$ to $-4.8V$                                                 |
|                                                                                                                                          |                                          | -169                 | -70   | -169                                 | -75   |         | $V_{EE} = -4.2V$ to $-5.7V$                                                 |

| <b>Industrial Version</b>                                                                                                                                |                                 |                      |       |                                      |       |         |                                       |
|----------------------------------------------------------------------------------------------------------------------------------------------------------|---------------------------------|----------------------|-------|--------------------------------------|-------|---------|---------------------------------------|
| <b>PCC ECL-to-TTL DC Electrical Characteristics</b>                                                                                                      |                                 |                      |       |                                      |       |         |                                       |
| $V_{EE} = -4.2V$ to $-5.7V$ , $V_{CC} = V_{CCA} = GND$ , $T_C = -40^{\circ}C$ to $+85^{\circ}C$ , $C_L = 50 pF$ , $V_{TTL} = +4.5V$ to $+5.5V$ (Note 12) |                                 |                      |       |                                      |       |         |                                       |
| Symbol                                                                                                                                                   | Parameter                       | $T_C = -40^{\circ}C$ |       | $T_C = 0^{\circ}C$ to $+85^{\circ}C$ |       | Units   | Conditions                            |
|                                                                                                                                                          |                                 | Min                  | Max   | Min                                  | Max   |         |                                       |
| $V_{OH}$                                                                                                                                                 | Output HIGH Voltage             | 2.7                  |       | 2.7                                  |       | V       | $I_{OH} = -3 mA$ , $V_{TTL} = 4.75V$  |
|                                                                                                                                                          |                                 | 2.4                  |       | 2.4                                  |       | V       | $I_{OH} = -3 mA$ , $V_{TTL} = 4.50V$  |
| $V_{OL}$                                                                                                                                                 | Output LOW Voltage              |                      | 0.5   |                                      | 0.5   | V       | $I_{OL} = 24 mA$ , $V_{TTL} = 4.50V$  |
| $V_{IH}$                                                                                                                                                 | Input HIGH Voltage              | -1170                | -870  | -1165                                | -870  | mV      | Guaranteed HIGH Signal for All Inputs |
| $V_{IL}$                                                                                                                                                 | Input LOW Voltage               | -1830                | -1480 | -1830                                | -1475 | mV      | Guaranteed LOW Signal for All Inputs  |
| $I_{IH}$                                                                                                                                                 | Input HIGH Current              |                      | 425   |                                      | 350   | $\mu A$ | $V_{IN} = V_{IH} (Max)$               |
| $I_{IL}$                                                                                                                                                 | Input LOW Current               | 0.50                 |       | 0.50                                 |       | $\mu A$ | $V_{IN} = V_{IH} (Min)$               |
| $I_{OZHT}$                                                                                                                                               | 3-STATE Current<br>Output High  |                      | 70    |                                      | 70    | $\mu A$ | $V_{OUT} = +2.7V$                     |
| $I_{OZLT}$                                                                                                                                               | 3-STATE Current<br>Output Low   | -700                 |       | -700                                 |       | $\mu A$ | $V_{OUT} = +0.5V$                     |
| $I_{OS}$                                                                                                                                                 | Output Short-Circuit<br>Current | -150                 | -60   | -150                                 | -60   | mA      | $V_{OUT} = 0.0V$ , $V_{TTL} = +5.5V$  |
| $I_{TTL}$                                                                                                                                                | $V_{TTL}$ Supply Current        |                      | 74    |                                      | 74    | mA      | TTL Outputs LOW                       |
|                                                                                                                                                          |                                 |                      | 49    |                                      | 49    | mA      | TTL Outputs HIGH                      |
|                                                                                                                                                          |                                 |                      | 67    |                                      | 67    | mA      | TTL Outputs in 3-STATE                |

**Note 12:** The specified limits represent the "worst case" value for the parameter. Since these values normally occur at the temperature extremes, additional noise immunity and guardbanding can be achieved by decreasing the allowable system operating ranges. Conditions for testing shown in the tables are chosen to guarantee operation under "worst case" conditions.



| Industrial Version<br>PCC TTL-to-ECL AC Electrical Characteristics  |                                              |                        |     |                       |     |                       |     |       |              |
|---------------------------------------------------------------------|----------------------------------------------|------------------------|-----|-----------------------|-----|-----------------------|-----|-------|--------------|
| V <sub>EE</sub> = -4.2V to -5.7V, V <sub>TTL</sub> = +4.5V to +5.5V |                                              |                        |     |                       |     |                       |     |       |              |
| Symbol                                                              | Parameter                                    | T <sub>C</sub> = -40°C |     | T <sub>C</sub> = 25°C |     | T <sub>C</sub> = 85°C |     | Units | Conditions   |
|                                                                     |                                              | Min                    | Max | Min                   | Max | Min                   | Max |       |              |
| t <sub>PLH</sub>                                                    | T <sub>n</sub> to E <sub>n</sub>             | 1.0                    | 3.3 | 1.1                   | 3.4 | 1.1                   | 3.6 | ns    | Figures 1, 2 |
| t <sub>PHL</sub>                                                    | (Transparent)                                |                        |     |                       |     |                       |     | ns    |              |
| t <sub>PLH</sub>                                                    | LE to E <sub>n</sub>                         | 1.7                    | 3.4 | 1.7                   | 3.5 | 1.9                   | 3.7 | ns    | Figures 1, 2 |
| t <sub>PHL</sub>                                                    |                                              |                        |     |                       |     |                       |     | ns    |              |
| t <sub>PZH</sub>                                                    | OE to E <sub>n</sub><br>(Cutoff to High)     | 1.2                    | 4.0 | 1.5                   | 4.2 | 1.7                   | 4.6 | ns    | Figures 1, 2 |
| t <sub>PHZ</sub>                                                    | OE to E <sub>n</sub><br>(High to Cutoff)     | 1.5                    | 4.5 | 1.6                   | 4.3 | 1.6                   | 4.4 | ns    |              |
| t <sub>PHZ</sub>                                                    | DIR to E <sub>n</sub><br>(High to Cutoff)    | 1.6                    | 4.1 | 1.6                   | 4.1 | 1.7                   | 4.3 | ns    | Figures 1, 2 |
| t <sub>set</sub>                                                    | T <sub>n</sub> to LE                         | 2.5                    |     | 1.0                   |     | 1.0                   |     | ns    |              |
| t <sub>hold</sub>                                                   | T <sub>n</sub> to LE                         | 1.0                    |     | 1.0                   |     | 1.0                   |     | ns    | Figures 1, 2 |
| t <sub>pw(H)</sub>                                                  | Pulse Width LE                               | 2.5                    |     | 2.0                   |     | 2.0                   |     | ns    |              |
| t <sub>TLH</sub>                                                    | Transition Time<br>20% to 80%, 80% to<br>20% | 0.4                    | 2.3 | 0.6                   | 1.6 | 0.6                   | 1.6 | ns    | Figures 1, 2 |
| t <sub>THL</sub>                                                    |                                              |                        |     |                       |     |                       |     |       |              |

| Industrial Version<br>PCC ECL-to-TTL AC Electrical Characteristics                          |                                  |                      |     |                       |      |                       |      |       |              |
|---------------------------------------------------------------------------------------------|----------------------------------|----------------------|-----|-----------------------|------|-----------------------|------|-------|--------------|
| V <sub>EE</sub> = -4.2V to -5.7V, V <sub>TTL</sub> = +4.5V to +5.5V, C <sub>L</sub> = 50 pF |                                  |                      |     |                       |      |                       |      |       |              |
| Symbol                                                                                      | Parameter                        | T <sub>C</sub> = 0°C |     | T <sub>C</sub> = 25°C |      | T <sub>C</sub> = 85°C |      | Units | Conditions   |
|                                                                                             |                                  | Min                  | Max | Min                   | Max  | Min                   | Max  |       |              |
| t <sub>PLH</sub>                                                                            | E <sub>n</sub> to T <sub>n</sub> | 2.3                  | 5.4 | 2.4                   | 5.4  | 2.6                   | 5.7  | ns    | Figures 3, 4 |
| t <sub>PHL</sub>                                                                            | (Transparent)                    |                      |     |                       |      |                       |      |       |              |
| t <sub>PLH</sub>                                                                            | LE to T <sub>n</sub>             | 3.1                  | 7.4 | 3.1                   | 7.0  | 3.3                   | 7.5  | ns    | Figures 3, 4 |
| t <sub>PHL</sub>                                                                            |                                  |                      |     |                       |      |                       |      |       |              |
| t <sub>PZH</sub>                                                                            | OE to T <sub>n</sub>             | 3.4                  | 8.3 | 3.7                   | 8.75 | 4.0                   | 9.5  | ns    | Figures 3, 5 |
| t <sub>PZL</sub>                                                                            | (Enable Time)                    | 3.7                  | 9.0 | 4.0                   | 9.0  | 4.3                   | 9.75 |       |              |
| t <sub>PHZ</sub>                                                                            | OE to T <sub>n</sub>             | 3.2                  | 9.0 | 3.3                   | 8.75 | 3.5                   | 9.0  | ns    | Figures 3, 5 |
| t <sub>PLZ</sub>                                                                            | (Disable Time)                   | 3.0                  | 7.5 | 3.4                   | 8.5  | 4.1                   | 9.75 |       |              |
| t <sub>PHZ</sub>                                                                            | DIR to T <sub>n</sub>            | 2.7                  | 8.0 | 2.8                   | 8.5  | 3.1                   | 8.75 | ns    | Figures 3, 5 |
| t <sub>PLZ</sub>                                                                            | (Disable Time)                   | 2.8                  | 7.3 | 3.1                   | 7.75 | 4.0                   | 9.0  |       |              |
| t <sub>set</sub>                                                                            | E <sub>n</sub> to LE             | 2.5                  |     | 1.0                   |      | 1.0                   |      | ns    | Figures 3, 4 |
| t <sub>hold</sub>                                                                           | E <sub>n</sub> to LE             | 2.3                  |     | 2.0                   |      | 2.5                   |      | ns    |              |
| t <sub>pw(H)</sub>                                                                          | Pulse Width LE                   | 4.0                  |     | 4.0                   |      | 4.0                   |      | ns    | Figures 3, 4 |
|                                                                                             |                                  |                      |     |                       |      |                       |      |       |              |

| <b>Military Version</b><br><b>TTL-to-ECL DC Electrical Characteristics</b><br>$V_{EE} = -4.2V$ to $-5.7V$ , $V_{CC} = V_{CCA} = GND$ , $T_C = -55^{\circ}C$ to $+125^{\circ}C$ , $V_{TTL} = +4.5V$ to $+5.5V$ |                           |       |       |         |                                   |                                              |                                    |                    |
|---------------------------------------------------------------------------------------------------------------------------------------------------------------------------------------------------------------|---------------------------|-------|-------|---------|-----------------------------------|----------------------------------------------|------------------------------------|--------------------|
| Symbol                                                                                                                                                                                                        | Parameter                 | Min   | Max   | Units   | $T_C$                             | Conditions                                   | Notes                              |                    |
| $V_{OH}$                                                                                                                                                                                                      | Output HIGH Voltage       | -1025 | -870  | mV      | $0^{\circ}C$ to $+125^{\circ}C$   | $V_{IN} = V_{IH}$ (Max)<br>or $V_{IL}$ (Min) | Loading with $50\Omega$ to $-2.0V$ | (Notes 13, 14, 15) |
|                                                                                                                                                                                                               |                           | -1085 | -870  | mV      | $-55^{\circ}C$                    |                                              |                                    |                    |
| $V_{OL}$                                                                                                                                                                                                      | Output LOW Voltage        | -1830 | -1620 | mV      | $0^{\circ}C$ to $+125^{\circ}C$   |                                              |                                    |                    |
|                                                                                                                                                                                                               |                           | -1830 | -1555 | mV      | $-55^{\circ}C$                    |                                              |                                    |                    |
|                                                                                                                                                                                                               | Cutoff Voltage            |       | -1950 | mV      | $0^{\circ}C$ to $+125^{\circ}C$   | OE or DIR Low                                |                                    |                    |
|                                                                                                                                                                                                               |                           |       | -1850 | mV      | $-55^{\circ}C$                    |                                              |                                    |                    |
| $V_{OHC}$                                                                                                                                                                                                     | Output HIGH Voltage       | -1035 |       | mV      | $0^{\circ}C$ to $+125^{\circ}C$   | $V_{IN} = V_{IH}$ (Min)<br>or $V_{IL}$ (Max) | Loading with $50\Omega$ to $-2.0V$ | (Notes 13, 14, 15) |
|                                                                                                                                                                                                               |                           | -1085 |       | mV      | $-55^{\circ}C$                    |                                              |                                    |                    |
| $V_{OLC}$                                                                                                                                                                                                     | Output LOW Voltage        |       | -1610 | mV      | $0^{\circ}C$ to $+125^{\circ}C$   |                                              |                                    |                    |
|                                                                                                                                                                                                               |                           |       | -1555 | mV      | $-55^{\circ}C$                    |                                              |                                    |                    |
| $V_{IH}$                                                                                                                                                                                                      | Input HIGH Voltage        | 2.0   |       | V       | $-55^{\circ}C$ to $+125^{\circ}C$ | Over $V_{TTL}$ , $V_{EE}$ , $T_C$ Range      | (Notes 13, 14, 15, 16)             |                    |
| $V_{IL}$                                                                                                                                                                                                      | Input LOW Voltage         |       | 0.8   | V       | $-55^{\circ}C$ to $+125^{\circ}C$ | Over $V_{TTL}$ , $V_{EE}$ , $T_C$ Range      | (Notes 13, 14, 15, 16)             |                    |
| $I_{IH}$                                                                                                                                                                                                      | Input HIGH Current        |       | 70    | $\mu A$ | $-55^{\circ}C$ to $125^{\circ}C$  | $V_{IN} = +2.7V$                             | (Notes 13, 14, 15)                 |                    |
|                                                                                                                                                                                                               | Breakdown Test            |       | 1.0   | mA      | $-55^{\circ}C$ to $+125^{\circ}C$ | $V_{IN} = +5.5V$                             |                                    |                    |
| $I_{IL}$                                                                                                                                                                                                      | Input LOW Current         | -1.0  |       | mA      | $-55^{\circ}C$ to $+125^{\circ}C$ | $V_{IN} = +0.5V$                             | (Notes 13, 14, 15)                 |                    |
| $V_{FCD}$                                                                                                                                                                                                     | Input Clamp Diode Voltage | -1.2  |       | V       | $-55^{\circ}C$ to $+125^{\circ}C$ | $I_{IN} = -18$ mA                            | (Notes 13, 14, 15)                 |                    |
| $I_{EE}$                                                                                                                                                                                                      | $V_{EE}$ Supply Current   |       |       |         | $-55^{\circ}C$ to $+125^{\circ}C$ | LE Low, OE and DIR High<br>Inputs Open       | (Notes 13, 14, 15)                 |                    |
|                                                                                                                                                                                                               |                           | -165  | -65   | mA      |                                   | $V_{EE} = -4.2V$ to $-4.8V$                  |                                    |                    |
|                                                                                                                                                                                                               |                           | -175  | -65   | mA      |                                   | $V_{EE} = -4.2V$ to $-5.7V$                  |                                    |                    |

| <b>Military Version</b><br><b>ECL-to-TTL DC Electrical Characteristics</b><br>$V_{EE} = -4.2V$ to $-5.7V$ , $V_{CC} = V_{CCA} = GND$ , $T_C = -55^{\circ}C$ to $+125^{\circ}C$ , $C_L = 50$ pF, $V_{TTL} = +4.5V$ to $+5.5V$ |                     |       |       |         |                                   |                                                                            |                        |
|------------------------------------------------------------------------------------------------------------------------------------------------------------------------------------------------------------------------------|---------------------|-------|-------|---------|-----------------------------------|----------------------------------------------------------------------------|------------------------|
| Symbol                                                                                                                                                                                                                       | Parameter           | Min   | Max   | Units   | $T_C$                             | Conditions                                                                 | Notes                  |
| $V_{OH}$                                                                                                                                                                                                                     | Output HIGH Voltage | 2.5   |       | mV      | $0^{\circ}C$ to $+125^{\circ}C$   | $I_{OH} = -1$ mA, $V_{TTL} = 4.50V$<br>$I_{OH} = -3$ mA, $V_{TTL} = 4.50V$ | (Notes 13, 14, 15)     |
|                                                                                                                                                                                                                              |                     | 2.4   |       | mV      | $-55^{\circ}C$                    |                                                                            |                        |
| $V_{OL}$                                                                                                                                                                                                                     | Output LOW Voltage  |       | 0.5   | mV      | $-55^{\circ}C$ to $+125^{\circ}C$ | $I_{OL} = 24$ mA, $V_{TTL} = 4.50V$                                        |                        |
| $V_{IH}$                                                                                                                                                                                                                     | Input HIGH Voltage  | -1165 | -870  | mV      | $-55^{\circ}C$ to $+125^{\circ}C$ | Guaranteed HIGH Signal for All Inputs                                      | (Notes 13, 14, 15, 16) |
| $V_{IL}$                                                                                                                                                                                                                     | Input LOW Voltage   | -1830 | -1475 | mV      | $-55^{\circ}C$ to $+125^{\circ}C$ | Guaranteed LOW Signal for All Inputs                                       | (Notes 13, 14, 15, 16) |
| $I_{IH}$                                                                                                                                                                                                                     | Input HIGH Current  |       | 350   | $\mu A$ | $0^{\circ}C$ to $+125^{\circ}C$   | $V_{EE} = -5.7V$                                                           | (Notes 13, 14, 15)     |
|                                                                                                                                                                                                                              |                     |       | 500   | $\mu A$ | $+125^{\circ}C$                   | $V_{IN} = V_{IH}$ (Max)                                                    |                        |

**Military Version  
ECL-to-TTL DC Electrical Characteristics** (Continued)

$V_{EE} = -4.2V$  to  $-5.7V$ ,  $V_{CC} = V_{CCA} = GND$ ,  $T_C = -55^{\circ}C$  to  $+125^{\circ}C$ ,  $C_L = 50$  pF,  $V_{TTL} = +4.5V$  to  $+5.5V$

| Symbol     | Parameter                       | Min  | Max            | Units          | $T_C$                             | Conditions                                                  | Notes              |
|------------|---------------------------------|------|----------------|----------------|-----------------------------------|-------------------------------------------------------------|--------------------|
| $I_{IL}$   | Input LOW Current               | 0.50 |                | $\mu A$        | $-55^{\circ}C$ to $+125^{\circ}C$ | $V_{EE} = -4.2V$<br>$V_{IN} = V_{IL}$ (Min)                 | (Notes 13, 14, 15) |
| $I_{OZHT}$ | 3-STATE Current<br>Output High  |      | 70             | $\mu A$        | $-55^{\circ}C$ to $+125^{\circ}C$ | $V_{OUT} = +2.7V$                                           | (Notes 13, 14, 15) |
| $I_{OZLT}$ | 3-STATE Current<br>Output Low   | -1.0 |                | mA             | $-55^{\circ}C$ to $+125^{\circ}C$ | $V_{OUT} = +0.5V$                                           | (Notes 13, 14, 15) |
| $I_{OS}$   | Output Short-Circuit<br>CURRENT | -150 | -60            | mA             | $-55^{\circ}C$ to $+125^{\circ}C$ | $V_{OUT} = 0.0V$ , $V_{TTL} = +5.5V$                        | (Notes 13, 14, 15) |
| $I_{TTL}$  | $V_{TTL}$ Supply Current        |      | 75<br>50<br>70 | mA<br>mA<br>mA | $-55^{\circ}C$ to $+125^{\circ}C$ | TTL Outputs Low<br>TTL Output High<br>TTL Output in 3-STATE | (Notes 13, 14, 15) |

**Note 13:** F100K 300 Series cold temperature testing is performed by temperature soaking (to guarantee junction temperature equals  $-55^{\circ}C$ ), then testing immediately without allowing for the junction temperature to stabilize due to heat dissipation after power-up. This provides "cold start" specs which can be considered a worst case condition at cold temperatures.

**Note 14:** Screen tested 100% on each device at  $-55^{\circ}C$ ,  $+25^{\circ}C$ , and  $+125^{\circ}C$ , Subgroups, 1, 2, 3, 7, and 8.

**Note 15:** Sample tested (Method 5005, Table I) on each manufactured lot at  $-55^{\circ}C$ ,  $+25^{\circ}C$ , and  $+125^{\circ}C$ , Subgroups A1, 2, 3, 7, and 8.

**Note 16:** Guaranteed by applying specified input condition and testing  $V_{OH}/V_{OL}$ .

**Military Version  
TTL-to-ECL AC Electrical Characteristics**

$V_{EE} = -4.2V$  to  $-5.7V$ ,  $V_{TTL} = +4.5V$  to  $+5.5V$ ,  $V_{CC} = V_{CCA} = GND$

| Symbol                 | Parameter                                 | $T_C = -55^{\circ}C$ |     | $T_C = 25^{\circ}C$ |     | $T_C = +125^{\circ}C$ |     | Units    | Conditions   | Notes              |
|------------------------|-------------------------------------------|----------------------|-----|---------------------|-----|-----------------------|-----|----------|--------------|--------------------|
|                        |                                           | Min                  | Max | Min                 | Max | Min                   | Max |          |              |                    |
| $t_{PLH}$<br>$t_{PHL}$ | $T_n$ to $E_n$<br>(Transparent)           | 0.8                  | 3.4 | 1.1                 | 3.6 | 0.8                   | 3.7 | ns<br>ns | Figures 1, 2 | (Notes 17, 18, 19) |
| $t_{PLH}$<br>$t_{PHL}$ | LE to $E_n$                               | 1.2                  | 3.8 | 1.4                 | 3.7 | 1.1                   | 3.8 | ns<br>ns | Figures 1, 2 |                    |
| $t_{PZH}$              | OE to $E_n$<br>(Cutoff to HIGH)           | 0.8                  | 3.6 | 1.5                 | 4.0 | 2.0                   | 5.2 | ns       | Figures 1, 2 | (Notes 17, 18, 19) |
| $t_{PHZ}$              | OE to $E_n$<br>(HIGH to Cutoff)           | 1.5                  | 4.6 | 1.6                 | 4.2 | 1.6                   | 4.3 | ns       | Figures 1, 2 |                    |
| $t_{PHZ}$              | DIR to $E_n$<br>(HIGH to Cutoff)          | 1.6                  | 4.7 | 1.6                 | 4.3 | 1.7                   | 4.3 | ns       | Figures 1, 2 |                    |
| $t_{set}$              | $T_n$ to LE                               | 2.5                  |     | 2.0                 |     | 2.5                   |     | ns       | Figures 1, 2 | (Note 20)          |
| $t_{hold}$             | $T_n$ to LE                               | 2.5                  |     | 2.0                 |     | 2.5                   |     | ns       | Figures 1, 2 |                    |
| $t_{pw}(H)$            | Pulse Width LE                            | 2.5                  |     | 2.0                 |     | 2.5                   |     | ns       | Figures 1, 2 | (Note 20)          |
| $t_{TLH}$<br>$t_{THL}$ | Transition Time<br>20% to 80%, 80% to 20% | 0.4                  | 2.3 | 0.5                 | 2.1 | 0.4                   | 2.4 | ns       | Figures 1, 2 | (Note 20)          |

| <b>Military Version</b><br><b>ECL-to-TTL AC Electrical Characteristics</b><br>$V_{EE} = -4.2V$ to $-5.7V$ , $V_{TTL} = +4.5V$ to $+5.5V$ , $V_{CC} = V_{CCA} = GND$ , $C_L = 50$ pF |                |                     |     |                    |     |                      |      |       |              |                    |
|-------------------------------------------------------------------------------------------------------------------------------------------------------------------------------------|----------------|---------------------|-----|--------------------|-----|----------------------|------|-------|--------------|--------------------|
| Symbol                                                                                                                                                                              | Parameter      | $T_C = -55^\circ C$ |     | $T_C = 25^\circ C$ |     | $T_C = +125^\circ C$ |      | Units | Conditions   | Notes              |
|                                                                                                                                                                                     |                | Min                 | Max | Min                | Max | Min                  | Max  |       |              |                    |
| $t_{PLH}$                                                                                                                                                                           | $E_n$ to $T_n$ | 2.1                 | 6.0 | 2.0                | 5.6 | 2.2                  | 6.3  | ns    | Figures 1, 2 | (Notes 17, 18, 19) |
| $t_{PHL}$                                                                                                                                                                           | (Transparent)  |                     |     |                    |     |                      |      |       |              |                    |
| $t_{PLH}$                                                                                                                                                                           | LE to $T_n$    | 3.1                 | 7.0 | 3.1                | 6.5 | 3.3                  | 7.5  | ns    | Figures 3, 4 |                    |
| $t_{PHL}$                                                                                                                                                                           |                |                     |     |                    |     |                      |      |       |              |                    |
| $t_{PZH}$                                                                                                                                                                           | OE to $T_n$    | 3.2                 | 8.0 | 3.7                | 8.0 | 4.0                  | 9.2  | ns    | Figures 3, 4 | (Notes 17, 18, 19) |
| $t_{PZL}$                                                                                                                                                                           | (Enable Time)  | 3.6                 | 8.0 | 4.0                | 8.5 | 4.3                  | 9.6  |       |              |                    |
| $t_{PHZ}$                                                                                                                                                                           | OE to $T_n$    | 3.2                 | 8.5 | 3.3                | 8.0 | 3.5                  | 8.4  | ns    | Figures 3, 5 |                    |
| $t_{PLZ}$                                                                                                                                                                           | (Disable Time) | 3.0                 | 8.0 | 3.4                | 7.5 | 4.1                  | 10.0 |       |              |                    |
| $t_{PHZ}$                                                                                                                                                                           | DIR to $T_n$   | 2.6                 | 7.0 | 2.6                | 7.0 | 2.9                  | 8.0  | ns    | Figures 3, 6 |                    |
| $t_{PLZ}$                                                                                                                                                                           | (Disable Time) | 2.7                 | 7.0 | 3.1                | 7.0 | 4.0                  | 10.0 |       |              |                    |
| $t_{set}$                                                                                                                                                                           | $E_n$ to LE    | 2.5                 |     | 2.0                |     | 2.5                  |      | ns    | Figures 3, 4 | (Note 20)          |
| $t_{hold}$                                                                                                                                                                          | $E_n$ to LE    | 3.0                 |     | 2.5                |     | 3.0                  |      | ns    | Figures 3, 4 |                    |
| $t_{pw}(H)$                                                                                                                                                                         | Pulse Width LE | 2.5                 |     | 2.0                |     | 5.0                  |      | ns    | Figures 3, 4 | (Note 20)          |

**Note 17:** F100K 300 Series cold temperature testing is performed by temperature soaking (to guarantee junction temperature equals  $-55^\circ C$ ), then testing immediately after power-up. This provides "cold start" specs which can be considered a worst case condition at cold temperatures.  
**Note 18:** Screen tested 100% on each device at  $+25^\circ C$ , temperature only, Subgroup A9.  
**Note 19:** Sample tested (Method 5005, Table I) on each mfg. lot at  $+25^\circ C$ , Subgroup A9, and at  $+125^\circ C$  and  $-55^\circ C$  temperatures, Subgroups A10 and A11.  
**Note 20:** Not tested at  $+25^\circ C$ ,  $+125^\circ C$  and  $-55^\circ C$  temperature (design characterization data).

### Test Circuitry (TTL-to-ECL)

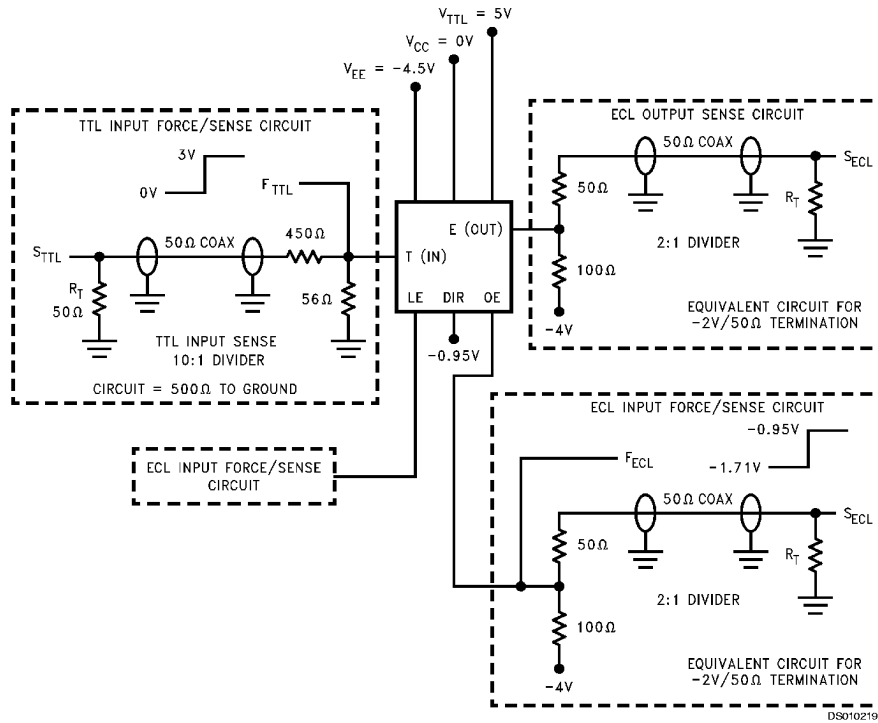

**Note 21:**  $R_T = 50\Omega$  termination. When an input or output is being monitored by a scope,  $R_T$  is supplied by the scope's  $50\Omega$  resistance. When an input or output is not being monitored, an external  $50\Omega$  resistance must be applied to serve as  $R_T$ .

**Note 22:** TTL and ECL force signals are brought to the DUT via  $50\Omega$  coax lines.

**Note 23:**  $V_{TTL}$  is decoupled to ground with  $0.1\ \mu\text{F}$  to ground,  $V_{EE}$  is decoupled to ground with  $0.01\ \mu\text{F}$  and  $V_{CC}$  is connected to ground.

**Note 24:** For ECL input pins, the equivalent force/sense circuitry is optional.

FIGURE 1. TTL-to-ECL AC Test Circuit

### Switching Waveforms (TTL-to-ECL)

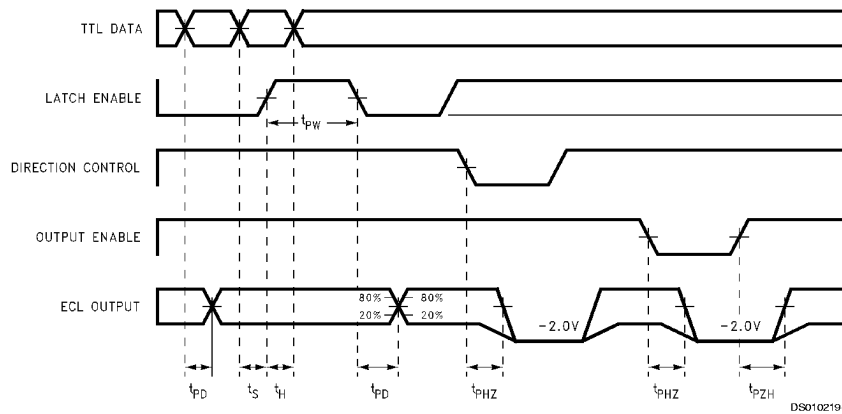
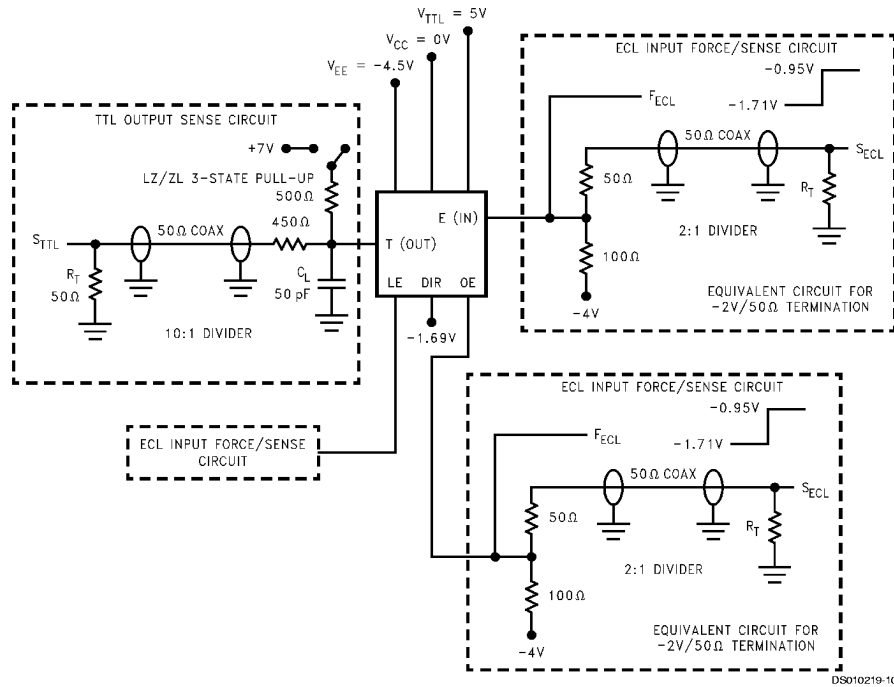

FIGURE 2. TTL to ECL Transition—Propagation Delay and Transition Times

### Test Circuitry (ECL-to-TTL)



DS010219-10

**Note 25:**  $R_t = 50\Omega$  termination. When an input or output is being monitored by a scope,  $R_t$  is supplied by the scope's  $50\Omega$  resistance. When an input or output is not being monitored, an external  $50\Omega$  resistance must be applied to serve as  $R_t$ .

**Note 26:** The TTL 3-State pull up switch is connected to +7V only for ZL and LZ tests.

**Note 27:** TTL and ECL force signals are brought to the DUT via  $50\Omega$  coax lines.

**Note 28:**  $V_{TTL}$  is decoupled to ground with  $0.1\ \mu\text{F}$ ,  $V_{EE}$  is decoupled to ground with  $0.01\ \mu\text{F}$  and  $V_{CC}$  is connected to ground.

FIGURE 3. ECL-to-TTL AC Test Circuit

### Switching Waveforms (ECL-to-TTL)

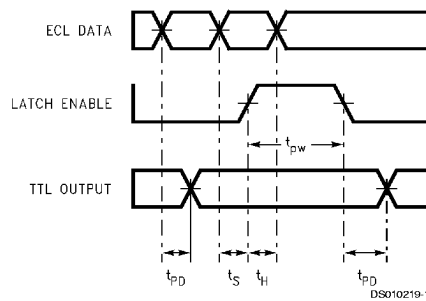

DS010219-11

**Note 29:** DIR is LOW, and OE is HIGH

FIGURE 4. ECL-to-TTL Transition—Propagation Delay and Transition Times

### Switching Waveforms (ECL-to-TTL) (Continued)

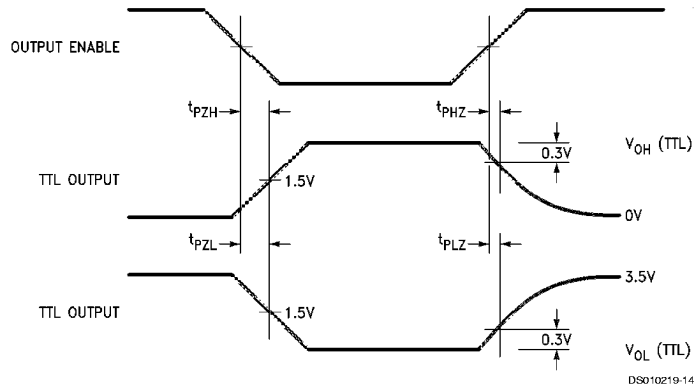

Note 30: DIR is LOW, LE is HIGH

FIGURE 5. ECL-to-TTL Transition, OE to TTL Output, Enable and Disable Times

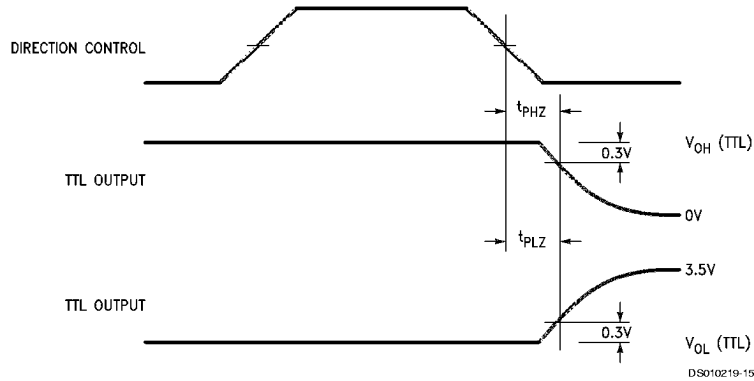

Note 31: OE is HIGH, LE is HIGH

FIGURE 6. ECL-to-TTL Transition, DIR to TTL Output, Disable Time

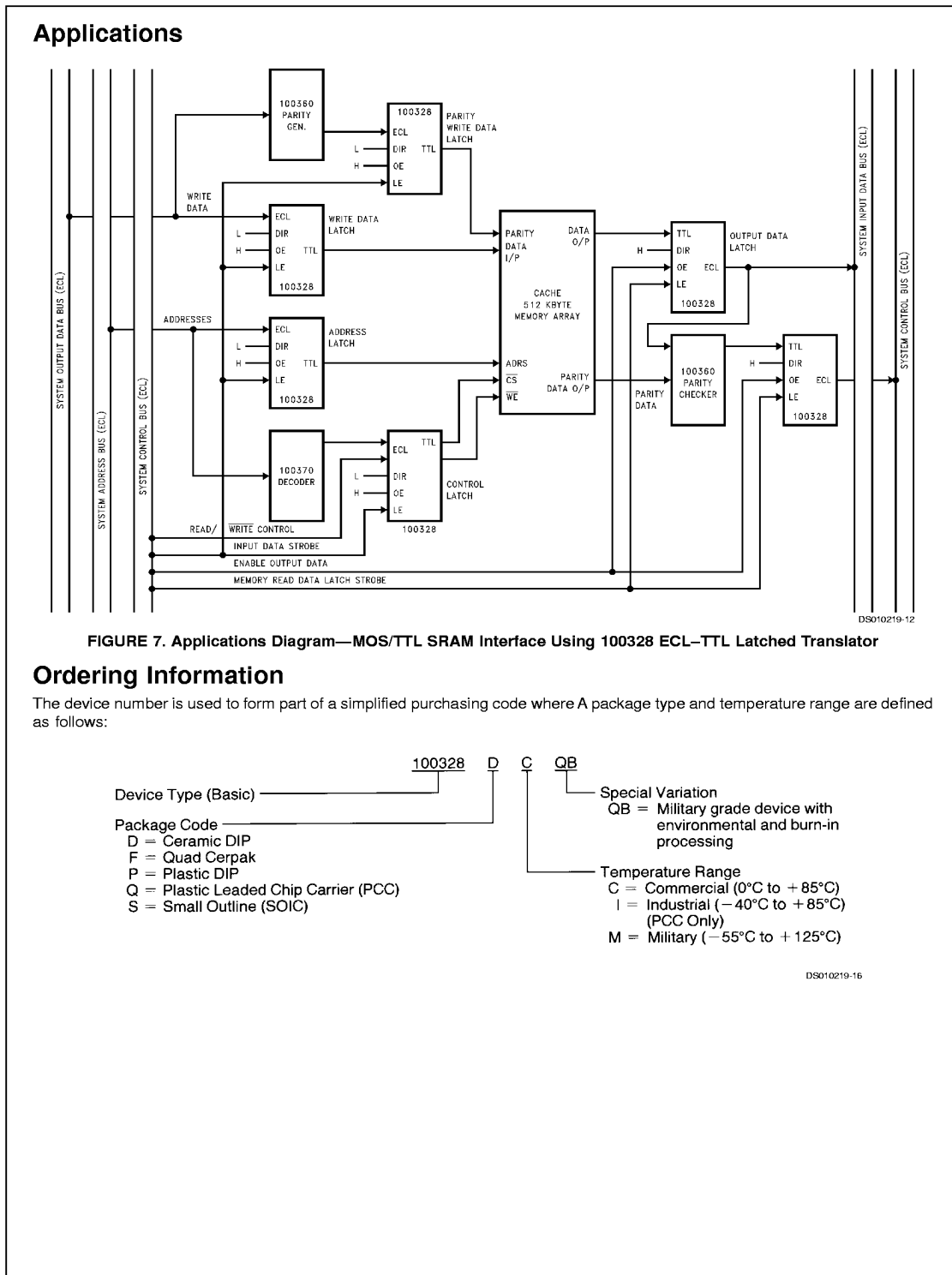



[查询"100328DC"供应商](#)

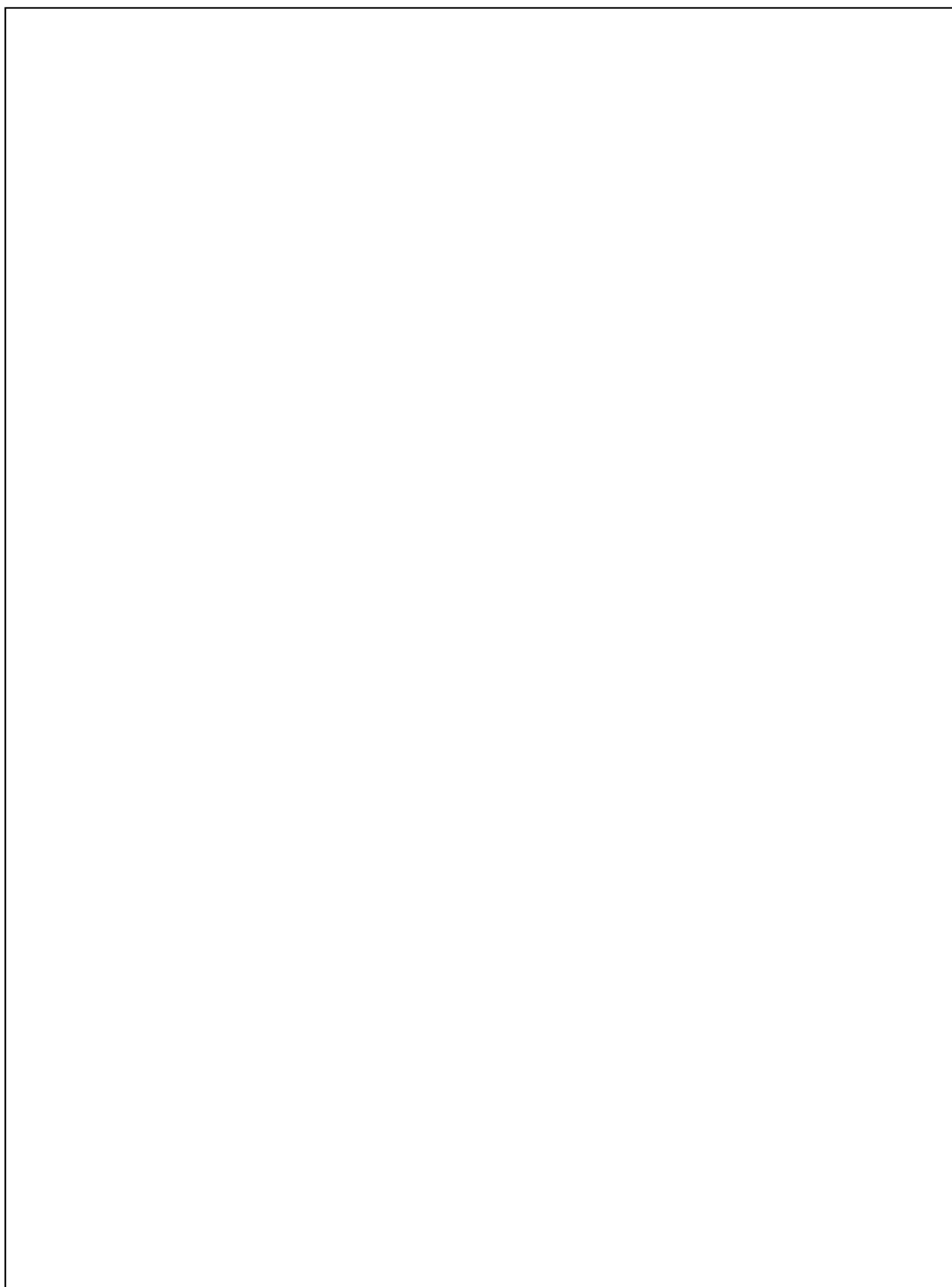

**Physical Dimensions** inches (millimeters) unless otherwise noted

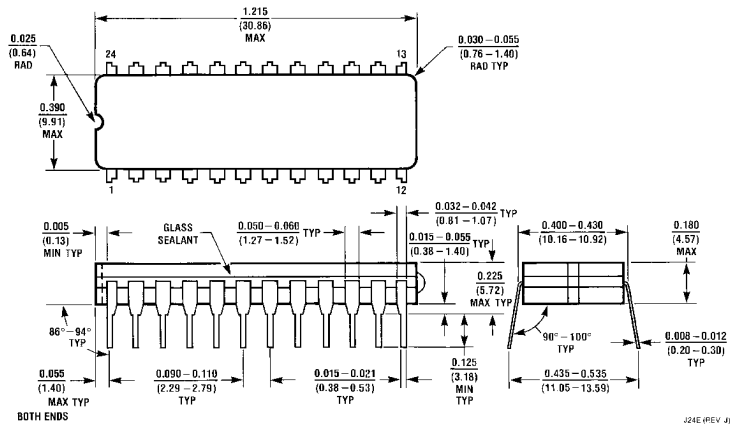

**24-Lead Ceramic Dual-In-Line Package (0.400" Wide) (D)**  
Package Number J24E

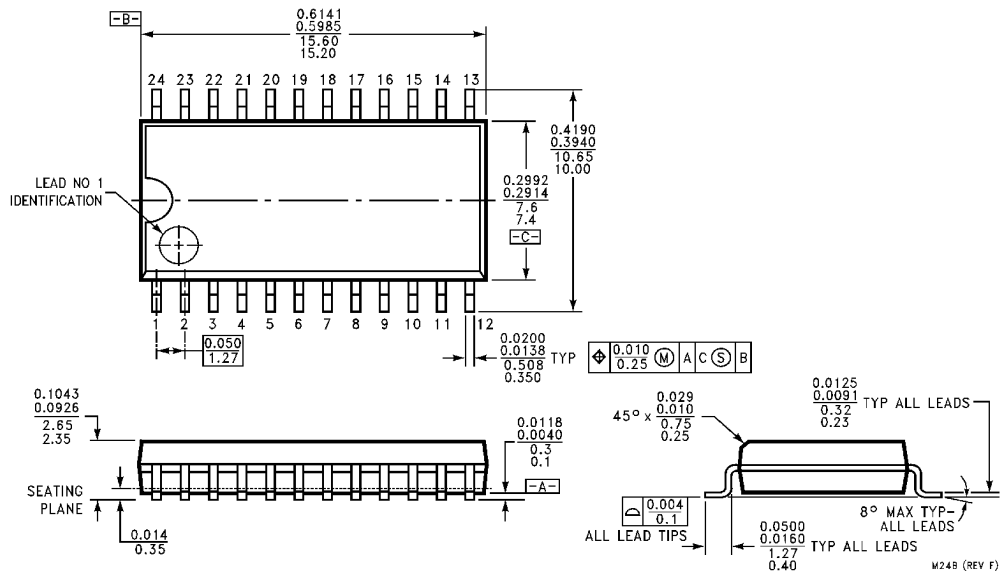

**24-Lead Molded Package (0.300" Wide) (S)**  
Package Number M24B

**Physical Dimensions** inches (millimeters) unless otherwise noted (Continued)

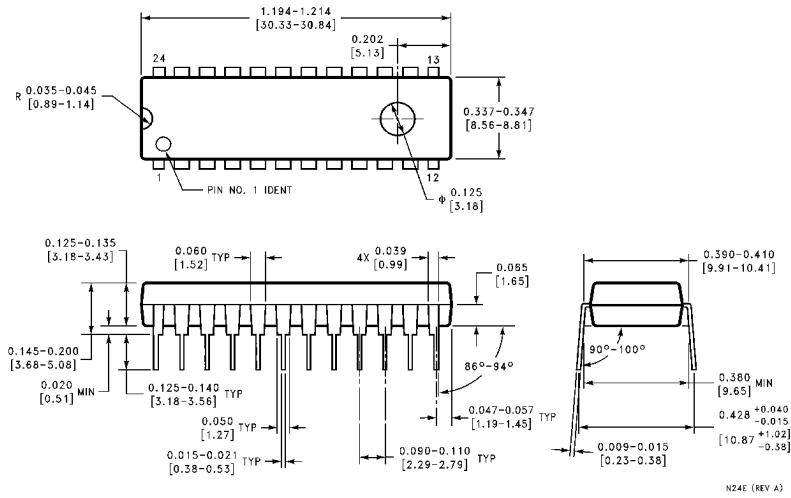

**24-Lead Plastic Dual-In-Line Package (P)**  
 Package Number N24E

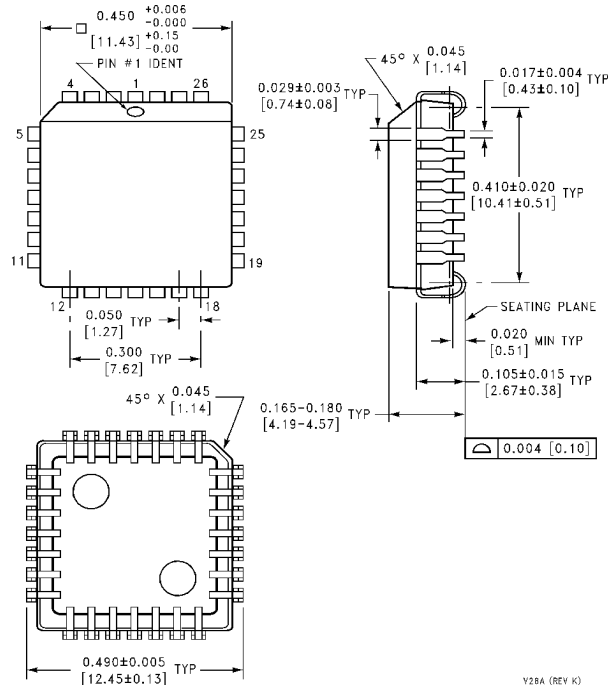

**28-Lead Plastic Chip Carrier (V)**  
 Package Number V28A

**Physical Dimensions** inches (millimeters) unless otherwise noted (Continued)

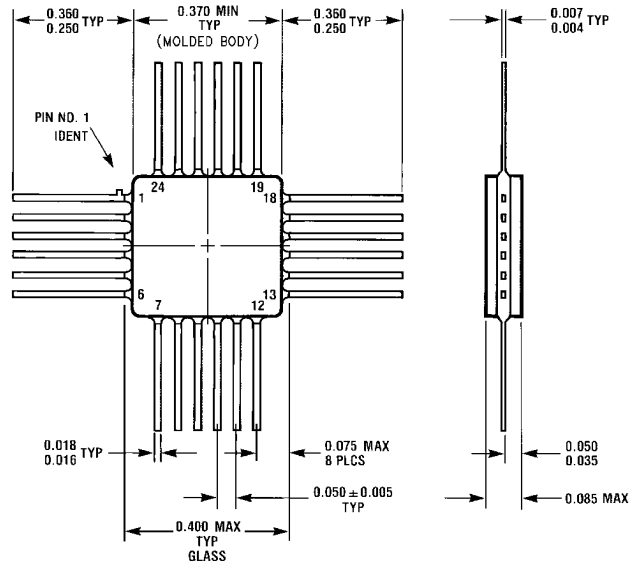

**24-Lead Quad Cerpak (F)  
Package Number W24B**

W24B (REV D)

**LIFE SUPPORT POLICY**

FAIRCHILD'S PRODUCTS ARE NOT AUTHORIZED FOR USE AS CRITICAL COMPONENTS IN LIFE SUPPORT DEVICES OR SYSTEMS WITHOUT THE EXPRESS WRITTEN APPROVAL OF THE PRESIDENT OF FAIRCHILD SEMICONDUCTOR CORPORATION. As used herein:

1. Life support devices or systems are devices or systems which, (a) are intended for surgical implant into the body, or (b) support or sustain life, and (c) whose failure to perform when properly used in accordance with instructions for use provided in the labeling, can be reasonably expected to result in a significant injury to the user.
2. A critical component in any component of a life support device or system whose failure to perform can be reasonably expected to cause the failure of the life support device or system, or to affect its safety or effectiveness.

Fairchild Semiconductor Corporation  
Americas  
Customer Response Center  
Tel: 1-888-522-5372

Fairchild Semiconductor Europe  
Fax: +49 (0) 1 80-530 85 86  
Email: europe.support@nsc.com  
Deutsch Tel: +49 (0) 8 141-35-0  
English Tel: +44 (0) 1 793-85-68-56  
Italy Tel: +39 (0) 2 57 5631

Fairchild Semiconductor Hong Kong Ltd.  
13th Floor, Straight Block,  
Ocean Centre, 5 Canton Rd.  
Tsimshatsui, Kowloon  
Hong Kong  
Tel: +852 2737-7200  
Fax: +852 2314-0061

National Semiconductor Japan Ltd.  
Tel: 81-3-5620-6175  
Fax: 81-3-5620-6179

[www.fairchildsemi.com](http://www.fairchildsemi.com)

Fairchild does not assume any responsibility for use of any circuitry described, no circuit patent licenses are implied and Fairchild reserves the right at any time without notice to change said circuitry and specifications.