

查询"74HCT240D"供应商

OCTAL BUFFER/LINE DRIVER, 3-STATE, INVERTING

FEATURES

- Output capability: bus driver
- I_{CC} category: MSI

GENERAL DESCRIPTION

The 74HC/HCT240 are high-speed Si-gate CMOS devices and are pin compatible with low power Schottky TTL (LSSTTL). They are specified in compliance with JEDEC standard no. 7A. The 74HC/HCT240 are octal inverting buffer/line drivers with 3-state outputs. The 3-state outputs are controlled by the output enable inputs 1OE and 2OE. A HIGH on nOE causes the outputs to assume a high impedance OFF-state. The "240" is identical to the "244" but has inverting outputs.

FUNCTION TABLE

INPUTS		OUTPUT
nOE	nA _n	nY _n
L	L	H
L	H	L
H	X	Z

H = HIGH voltage level
L = LOW voltage level
X = don't care
Z = high impedance OFF-state

SYMBOL	PARAMETER	CONDITIONS	TYPICAL		UNIT
			HC	HCT	
t _{PHL} / t _{PLH}	propagation delay 1A _n to 1Y _n ; 2A _n to 2Y _n	C _L = 15 pF V _{CC} = 5 V	9	9	ns
C _I	input capacitance		3.5	3.5	pF
CPD	power dissipation capacitance per buffer	notes 1 and 2	30	30	pF

GND = 0 V; T_{amb} = 25 °C; t_r = t_f = 6 ns

Notes

- CPD is used to determine the dynamic power dissipation (P_D in μW):

$$P_D = CPD \times V_{CC}^2 \times f_i + \sum (C_L \times V_{CC}^2 \times f_o)$$
 where:
 f_i = input frequency in MHz
 f_o = output frequency in MHz
 ∑ (C_L × V_{CC}² × f_o) = sum of outputs
 C_L = output load capacitance in pF
 V_{CC} = supply voltage in V
- For HC the condition is V_I = GND to V_{CC}
 For HCT the condition is V_I = GND to V_{CC} - 1.5 V

PACKAGE OUTLINES

20-lead DIL; plastic (SOT146).
20-lead mini-pack; plastic (SO20; SOT163A).

PIN DESCRIPTION

PIN NO.	SYMBOL	NAME AND FUNCTION
1	1OE	output enable input (active LOW)
2, 4, 6, 8	1A ₀ to 1A ₃	data inputs
3, 5, 7, 9	2Y ₀ to 2Y ₃	bus outputs
10	GND	ground (0 V)
17, 15, 13, 11	2A ₀ to 2A ₃	data inputs
18, 16, 14, 12	1Y ₀ to 1Y ₃	bus outputs
19	2OE	output enable input (active LOW)
20	V _{CC}	positive supply voltage

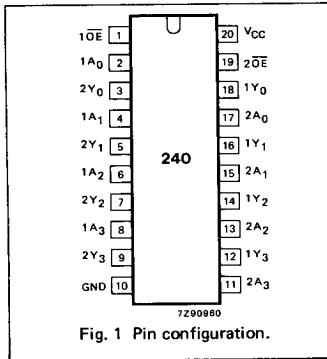

Fig. 1 Pin configuration.

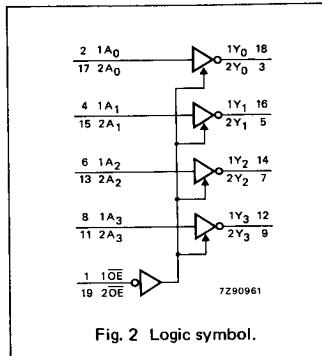

Fig. 2 Logic symbol.

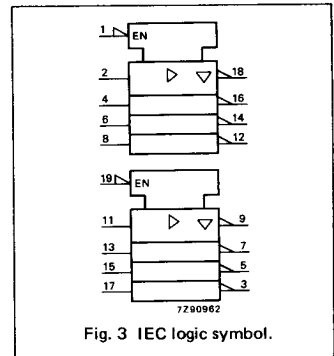
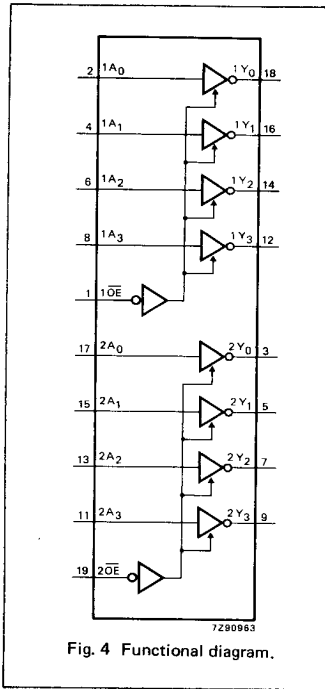

Fig. 3 IEC logic symbol.

[查询"74HCT240D-T"供应商](#)



[查询"74HCT240D-T"供应商](#)

DC CHARACTERISTICS FOR 74HC

For the DC characteristics see chapter "HCMOS family characteristics", section "Family specifications".

Output capability: bus driver

I_{CC} category: MSI

AC CHARACTERISTICS FOR 74HC

GND = 0 V; t_r = t_f = 6 ns; C_L = 50 pF

SYMBOL	PARAMETER	T _{amb} (°C)						UNIT	TEST CONDITIONS		
		74HC							V _{CC} V	WAVEFORMS	
		+25			-40 to +85		-40 to +125				
		min.	typ.	max.	min.	max.	min.				max.
t _{PHL} / t _{PLH}	propagation delay 1A _n to 1Y _n ; 2A _n to 2Y _n		30 11 9	100 20 17		125 25 21		150 30 26	ns	2.0 4.5 6.0	Fig. 5
t _{PZH} / t _{PZL}	3-state output enable time 1OE to 1Y _n ; 2OE to 2Y _n		39 14 11	150 30 26		190 38 33		225 45 38	ns	2.0 4.5 6.0	Fig. 6
t _{PHZ} / t _{PLZ}	3-state output disable time 1OE to 1Y _n ; 2OE to 2Y _n		41 15 12	150 30 26		190 38 33		225 45 38	ns	2.0 4.5 6.0	Fig. 6
t _{THL} / t _{TLH}	output transition time		14 5 4	60 12 10		75 15 13		90 18 15	ns	2.0 4.5 6.0	Fig. 5

[查询"74HCT240D-T"供应商](#)

DC CHARACTERISTICS FOR 74HCT

For the DC characteristics see chapter "HCMOS family characteristics", section "Family specifications".

Output capability: bus driver

I_{CC} category: MSI

Note to HCT types

The value of additional quiescent supply current (ΔI_{CC}) for a unit load of 1 is given in the family specifications. To determine ΔI_{CC} per input, multiply this value by the unit load coefficient shown in the table below.

input	unit load coefficient
1A _n	1.50
2A _n	1.50
1OE	0.70
2OE	0.70

AC CHARACTERISTICS FOR 74HCT

GND = 0 V; t_r = t_f = 6 ns; C_L = 50 pF

SYMBOL	PARAMETER	T _{amb} (°C)						UNIT	TEST CONDITIONS		
		74HCT							V _{CC} V	WAVEFORMS	
		+25			-40 to +85		-40 to +125				
		min.	typ.	max.	min.	max.	min.				max.
t _{PHL} / t _{PLH}	propagation delay 1A _n to 1Y _n ; 2A _n to 2Y _n		11	20		25		30	ns	4.5	Fig. 5
t _{PZH} / t _{PZL}	3-state output enable time 1OE to 1Y _n ; 2OE to 2Y _n		13	30		38		45	ns	4.5	Fig. 6
t _{PHZ} / t _{PLZ}	3-state output disable time 1OE to 1Y _n ; 2OE to 2Y _n		13	25		31		38	ns	4.5	Fig. 6
t _{THL} / t _{TLH}	output transition time		5	12		15		18	ns	4.5	Fig. 5

[查询"74HCT240D-T"供应商](#)

AC WAVEFORMS

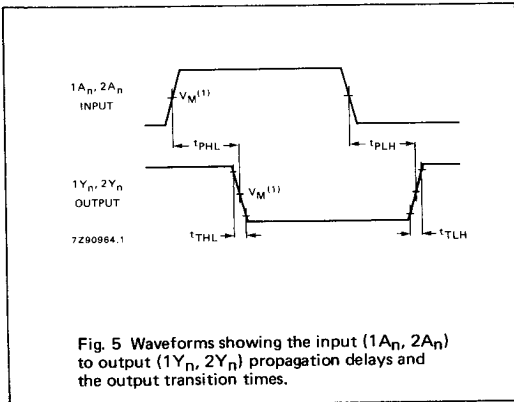

Fig. 5 Waveforms showing the input ($1A_n, 2A_n$) to output ($1Y_n, 2Y_n$) propagation delays and the output transition times.

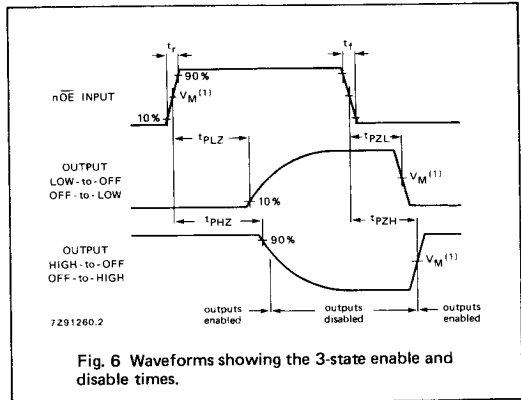

Fig. 6 Waveforms showing the 3-state enable and disable times.

Note to AC waveforms

- (1) HC : $V_M = 50\%$; $V_I = \text{GND to } V_{CC}$.
- HCT: $V_M = 1.3 \text{ V}$; $V_I = \text{GND to } 3 \text{ V}$.