

REVISIONS																
LTR	DESCRIPTION	DATE (YR-MO-DA)					APPROVED									
查询"5962-9160001HXA"供应商 B	Figure 1; Case outline Z. Changed the dimension (s) from .320 inches min and .340 inches max to .200 inches min and .210 inches max. Changed the dimension (s) millimeters min and max from 8.13 mm to 5.08 mm and 8.64 mm to 5.33 mm. Redrew entire document. -sld	99-02-03					K.A. Cottongim									
REV																
SHEET																
REV																
SHEET																
REV STATUS	REV	B	B	B	B	B	B	B	B	B	B	B	B	B	B	B
OF SHEETS	SHEET	1	2	3	4	5	6	7	8	9	10	11	12	13		
PMIC N/A	PREPARED BY Steve L. Duncan	DEFENSE SUPPLY CENTER COLUMBUS COLUMBUS, OHIO 43216														
STANDARD MICROCIRCUIT DRAWING	CHECKED BY Michael C. Jones	MICROCIRCUIT, HYBRID, LINEAR, 5 VOLT, SINGLE CHANNEL, DC/DC CONVERTER														
THIS DRAWING IS AVAILABLE FOR USE BY ALL DEPARTMENTS AND AGENCIES OF THE DEPARTMENT OF DEFENSE	APPROVED BY Gregory A. Lude	DRAWING APPROVAL DATE 92-07-01														
AMSC N/A	REVISION LEVEL B	SIZE A	CAGE CODE 67268	5962-91600												
		SHEET		1 OF 13												

DSCC FORM 2233
APR 97

5962-E127-99

DISTRIBUTION STATEMENT A. Approved for public release; distribution is unlimited.

1. SCOPE

[查询"5962-91600-1 HXA"供应商](#)

Scope For Drawing Documents: Five product assurance classes, class D (lowest reliability), class E, (exceptions), class G (lowest high reliability), class H (high reliability), and class K, (highest reliability) and a choice of case outlines and lead finishes are available and are reflected in the Part or Identifying Number (PIN). When available, a choice of radiation hardness assurance levels are reflected in the PIN.

1.2 PIN. The PIN shall be as shown in the following example:

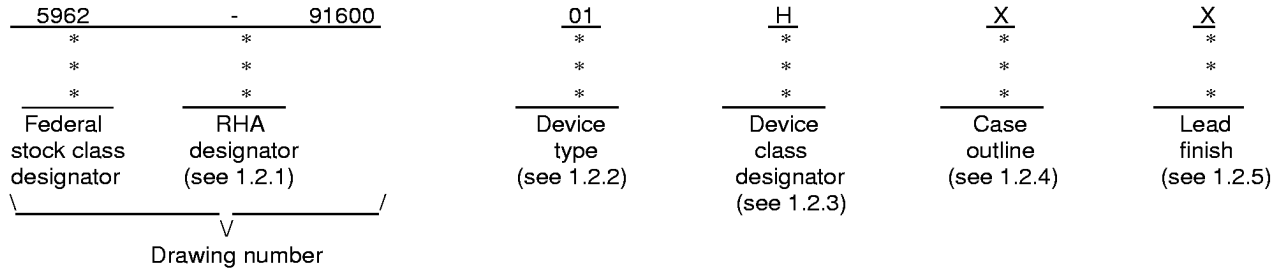

1.2.1 Radiation hardness assurance (RHA) designator. Device classes H and K RHA marked devices shall meet the MIL-PRF-38534 specified RHA levels and shall be marked with the appropriate RHA designator. A dash (-) indicates a non-RHA device.

1.2.2 Device type(s). The device type(s) identify the circuit function as follows:

<u>Device type</u>	<u>Generic number</u>	<u>Circuit function</u>
01	AHF2805S/CH, AHF2805SF/CH	DC-DC converter , 12 W, 5 V output

1.2.3 Device class designator. This device class designator shall be a single letter identifying the product assurance level as follows:

<u>Device class</u>	<u>Device performance documentation</u>
D, E, G, H, or K	Certification and qualification to MIL-PRF-38534

1.2.4 Case outline(s). The case outline(s) are as designated in MIL-STD-1835 and as follows:

<u>Outline letter</u>	<u>Descriptive designator</u>	<u>Terminals</u>	<u>Package style</u>
X	See figure 1	8	Dual-in-line
Z	See figure 1	8	Flange package

1.2.5 Lead finish. The lead finish shall be as specified in MIL-PRF-38534.

STANDARD MICROCIRCUIT DRAWING DEFENSE SUPPLY CENTER COLUMBUS COLUMBUS, OHIO 43216-5000	SIZE A		5962-91600
		REVISION LEVEL B	SHEET 2

1.3 Absolute maximum ratings. 1/
[查询"5962-9160001HXA"供应商](#)

Input voltage range ----- -0.5 V dc to +50 V dc
 Power dissipation (P_D) ----- 6 W
 Lead temperature (soldering, 10 seconds)----- +300°C
 Storage temperature range----- -65°C to +150°C

1.4 Recommended operating conditions.

Input voltage range ----- +16 V dc to +40 V dc
 Output power----- ≤12 W
 Case operating temperature range (T_C) ----- -55°C to 125°C

2. APPLICABLE DOCUMENTS

2.1 Government specification, standards, and handbook. The following specification, standards, and handbook form a part of this drawing to the extent specified herein. Unless otherwise specified, the issues of these documents are those listed in the issue of the Department of Defense Index of Specifications and Standards (DoDISS) and supplement thereto, cited in the solicitation.

SPECIFICATION

DEPARTMENT OF DEFENSE

MIL-PRF-38534 - Hybrid Microcircuits, General Specification for.

STANDARDS

DEPARTMENT OF DEFENSE

MIL-STD-883 - Test Methods and Procedures for Microelectronics.
 MIL-STD-973 - Configuration Management.
 MIL-STD-1835 - Microcircuit Case Outlines.

HANDBOOK

DEPARTMENT OF DEFENSE

MIL-HDBK-780 - Standard Microcircuit Drawings.

(Unless otherwise indicated, copies of the specification, standards, and handbook are available from the Standardization Document Order Desk, 700 Robbins Avenue, Building 4D, Philadelphia, PA 19111-5094.)

2.2 Order of precedence. In the event of a conflict between the text of this drawing and the references cited herein, the text of this drawing takes precedence. Nothing in this document, however, supersedes applicable laws and regulations unless a specific exemption has been obtained.

1/Stresses above the absolute maximum rating may cause permanent damage to the device. Extended operation at the maximum levels may degrade performance and affect reliability.

STANDARD MICROCIRCUIT DRAWING DEFENSE SUPPLY CENTER COLUMBUS COLUMBUS, OHIO 43216-5000	SIZE A		5962-91600
		REVISION LEVEL B	SHEET 3

3. REQUIREMENTS

查询"5962-9160001HXA"供应商

3.1 Item requirements. The individual item performance requirements for device classes D, E, G, H, and K shall be in accordance with MIL-PRF-38534. Compliance with MIL-PRF-38534 may include the performance of all tests herein or as designated in the device manufacturer's Quality Management (QM) plan or as designated for the applicable device class. Therefore, the tests and inspections herein may not be performed for the applicable device class (see MIL-PRF-38534). Furthermore, the manufacturers may take exceptions or use alternate methods to the tests and inspections herein and not perform them. However, the performance requirements as defined in MIL-PRF-38534 shall be met for the applicable device class.

3.2 Design, construction, and physical dimensions. The design, construction, and physical dimensions shall be as specified in MIL-PRF-38534 and herein.

3.2.1 Case outline(s). The case outline(s) shall be in accordance with 1.2.4 herein and figure 1.

3.2.2 Terminal connections. The terminal connections shall be as specified on figure 2.

3.3 Electrical performance characteristics. Unless otherwise specified herein, the electrical performance characteristics are as specified in table I and shall apply over the full specified operating temperature range.

3.4 Electrical test requirements. The electrical test requirements shall be the subgroups specified in table II. The electrical tests for each subgroup are defined in table I.

3.5 Marking of Device(s). Marking of device(s) shall be in accordance with MIL-PRF-38534. The device shall be marked with the PIN listed in 1.2 herein. In addition, the manufacturer's vendor similar PIN may also be marked as listed in QML-38534.

3.6 Data. In addition to the general performance requirements of MIL-PRF-38534, the manufacturer of the device described herein shall maintain the electrical test data (variables format) from the initial quality conformance inspection group A lot sample, for each device type listed herein. Also, the data should include a summary of all parameters manually tested, and for those which, if any, are guaranteed. This data shall be maintained under document revision level control by the manufacturer and be made available to the preparing activity (DSCC-VA) upon request.

3.7 Certificate of compliance. A certificate of compliance shall be required from a manufacturer in order to supply to this drawing. The certificate of compliance (original copy) submitted to DSCC-VA shall affirm that the manufacturer's product meets the performance requirements of MIL-PRF-38534 and herein.

3.8 Certificate of conformance. A certificate of conformance as required in MIL-PRF-38534 shall be provided with each lot of microcircuits delivered to this drawing.

4. QUALITY ASSURANCE PROVISIONS

4.1 Sampling and inspection. Sampling and inspection procedures shall be in accordance with MIL-PRF-38534 or as modified in the device manufacturer's Quality Management (QM) plan. The modification in the QM plan shall not affect the form, fit, or function as described herein.

STANDARD MICROCIRCUIT DRAWING DEFENSE SUPPLY CENTER COLUMBUS COLUMBUS, OHIO 43216-5000	SIZE A		5962-91600
		REVISION LEVEL B	SHEET 4

TABLE I. Electrical performance characteristics.
[查询"5962-9160001HXA"供应商](#)

Test	Symbol	Conditions -55°C ≤ T _C ≤ +125°C V _{IN} = 28 V dc ±5 %, C _L = 0 unless otherwise specified	Group A subgroups	Device type	Limits		Unit
					Min	Max	
Output voltage	V _{OUT}	I _{OUT} = 0	1	01	4.95	5.05	V dc
			2,3	01	4.90	5.10	
Output current <u>1</u> /	I _{OUT}	V _{IN} = 16, 28, and 40 V dc	1,2,3	01	0.0	2400	mA
Output ripple voltage <u>2</u> /	V _{RIP}	V _{IN} = 16, 28, and 40 V dc, B.W. = 20 Hz to 2 MHz	1,2,3	01		60	mV p-p
Output power <u>1</u> /	P _{OUT}	V _{IN} = 16, 28, and 40 V dc	1,2,3	01	12		W
Line regulation	V _{RLINE}	V _{IN} = 16, 28, and 40 V dc, I _{OUT} = 0, 1.2, and 2.4 A	1,2,3	01		25	mV
Load regulation	V _{RLOAD}	V _{IN} = 16, 28, and 40 V dc, I _{OUT} = 0, 1.2, and 2.4 A	1,2,3	01		50	
Input current	I _{IN}	I _{OUT} = 0, inhibit (pin 1) is converted to input return (pin 7)	1,2,3	01		12	mA
		I _{OUT} = 0, inhibit (pin 1) open				30	
Input ripple current	I _{RIP}	I _{OUT} = 2.4 A, B.W. = 20 Hz to 2 MHz	1,2,3	01		50	mA p-p
Efficiency	Eff	I _{OUT} = 2.4 A	1	01	76		%
Isolation	ISO	Input to output or any pin to case (except pin 6) at 500 V dc	1	01	100		MΩ
Capacitive load <u>3</u> / <u>4</u> /	C _L	No effect on dc performance	4	01		500	μF

See footnotes at end of table.

STANDARD MICROCIRCUIT DRAWING DEFENSE SUPPLY CENTER COLUMBUS COLUMBUS, OHIO 43216-5000	SIZE A		5962-91600
		REVISION LEVEL B	SHEET 5

TABLE I. Electrical performance characteristics – Continued.
[查询"5962-9160001HXA"供应商](#)

Test	Symbol	Conditions -55°C ≤ T _C ≤ +125°C V _{IN} = 28 V dc ±5 %, C _L = 0 unless otherwise specified	Group A subgroups	Device type	Limits		Unit
					Min	Max	
Power dissipation, load fault	P _D	Overload <u>5/</u>	1	01		6	W
		Short circuit				2.0	
Switching frequency	F _S	I _{OUT} = 2.4 A	4,5,6	01	500	600	kHz
Output response to step transient load changes <u>6/</u>	V _O T _{LOAD}	50% load to/from 100% load	4,5,6	01	-300	+300	mV pk
		No load to/from 50% load			-500	+500	
Recovery time, step transient load changes <u>6/ 7/</u>	T _T LOAD	50% load to/from 100% load	4,5,6	01		70	μs
		No load to 50% load				1200	
		50% load to no load				8	ms
Output response to transient step line changes <u>4/ 8/</u>	V _O T _{LINE}	Input step from 16 to 40 V dc, I _{OUT} = 2.4 A	4,5,6	01		500	mV pk
		Input step from 40 to 16 V dc, I _{OUT} = 2.4 A				500	
Recovery time, transient step line changes <u>4/ 7/</u>	T _T LINE	Input step from 16 to 40 V dc, I _{OUT} = 2.4 A	4,5,6	01		800	μs
		Input step from 40 to 16 V dc, I _{OUT} = 2.4 A				800	
Turn-on overshoot	V _{tonOS}	I _{OUT} = 0 and 2.4 A	4,5,6	01		600	mV pk

See footnotes at end of table.

STANDARD MICROCIRCUIT DRAWING DEFENSE SUPPLY CENTER COLUMBUS COLUMBUS, OHIO 43216-5000	SIZE A		5962-91600
		REVISION LEVEL B	SHEET 6

TABLE I. Electrical performance characteristics - Continued.
[查询"5962-9160001HXA"供应商](#)

Test	Symbol	Conditions -55°C ≤ T _C ≤ +125°C V _{IN} = 28 V dc ±5 %, C _L = 0 unless otherwise specified	Group A subgroups	Device type	Limits		Unit
					Min	Max	
Turn-on delay <u>9/</u>	T _{onD}	I _{OUT} = 0 and 2.4 A	4,5,6	01		20	ms
Load fault recovery <u>4/</u>	T _{rLF}		4,5,6	01		20	ms

- 1/ Parameter guaranteed by line and load regulation tests.
- 2/ Bandwidth guaranteed by design. Tested for 20 kHz to 2 MHz..
- 3/ Capacitive load may be any value from 0 to the maximum limit without compromising DC performance. A capacitive load in excess of the maximum limit will not disturb loop stability but will interfere with the operation of the load fault detection circuitry, appearing as a short circuit during turn on.
- 4/ Parameter shall be tested as part of design characterization and after any design or process change. Therefore this parameter shall be guaranteed to the limits specified in table I.
- 5/ An overload is that condition with a load in excess of the rated load but less than that necessary to trigger the short circuit protection and is the condition of maximum power dissipation.
- 6/ Load step transition time between 2 and 10 microseconds.
- 7/ Recovery time is measured from the initiation of the transient to where V_{OUT} has returned to within ±1 percent of V_{OUT} at 50 percent load.
- 8/ Input step transition time between 2 and 10 microseconds. Parameter guaranteed by design but not 100 percent tested.
- 9/ Turn-on delay time measurement is for either a step application of power at the input or the removal of a ground signal from the inhibit pin (pin 1) while power is applied to the input.

STANDARD MICROCIRCUIT DRAWING DEFENSE SUPPLY CENTER COLUMBUS COLUMBUS, OHIO 43216-5000	SIZE A		5962-91600
		REVISION LEVEL B	SHEET 7

[查询"5962-9160001HXA"供应商](#)

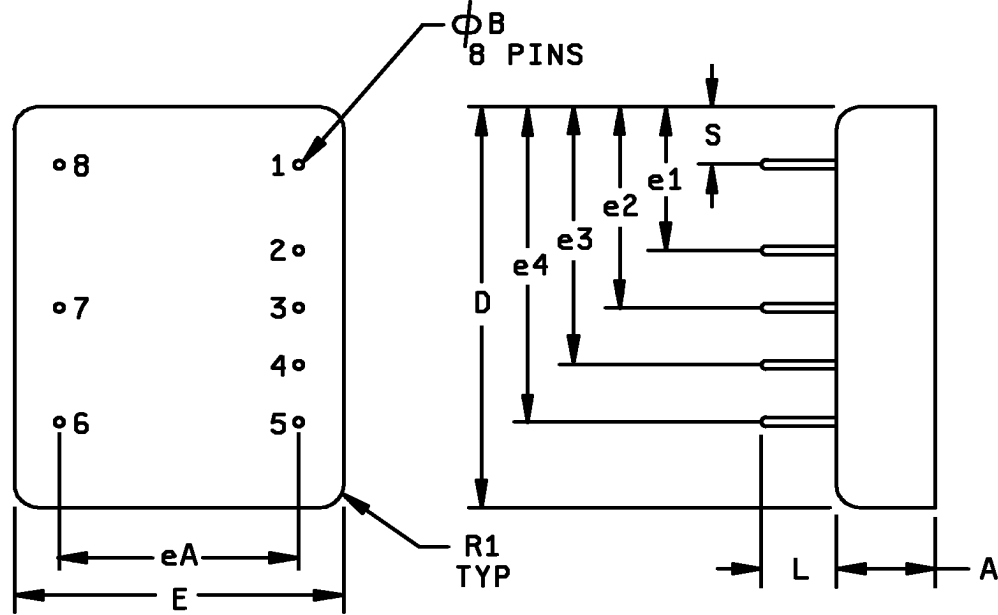

Symbol	Millimeters		Inches	
	Min	Max	Min	Max
A		8.38		.330
ϕB	0.64	0.89	.025	.035
D	36.70	36.96	1.445	1.455
eA	20.19	20.45	.795	.805
e1	12.70	12.95	.500	.510
e2	17.78	18.03	.700	.710
e3	22.86	23.11	.900	.910
e4	27.94	28.19	1.100	1.110
E	28.32	28.58	1.115	1.125
L	6.35	6.86	.250	.270
R1	2.03	2.54	.080	.100
S	5.08	5.33	.200	.210

NOTES:

1. The U.S. government preferred system of measurement is the metric SI. This item was designed using inch-pound units of measurement. In case of problems involving conflicts between the metric and inch-pound units, the inch-pound units shall rule.
2. Case outline X weight: 30 grams maximum.

FIGURE 1. Case outline.

STANDARD MICROCIRCUIT DRAWING DEFENSE SUPPLY CENTER COLUMBUS COLUMBUS, OHIO 43216-5000	SIZE A		5962-91600
		REVISION LEVEL B	SHEET 8

[查询"5962-916001HXA"供应商](#)

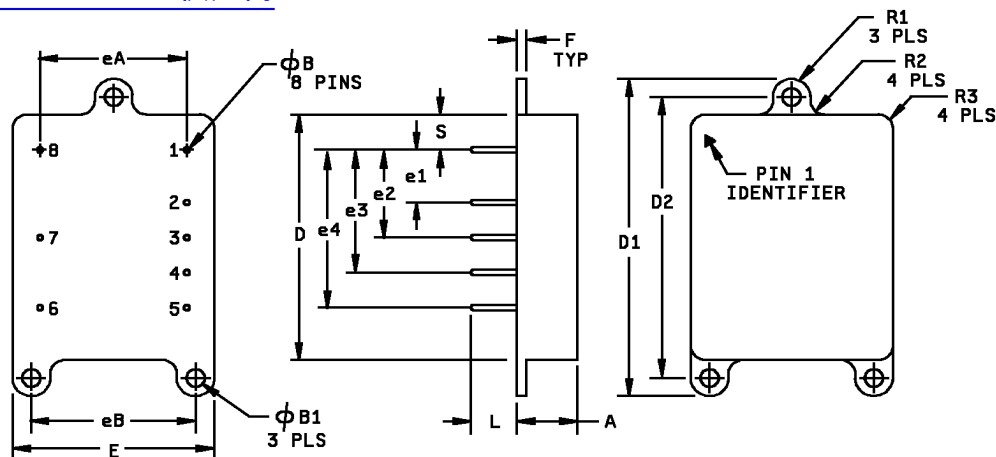

Symbol	Millimeters		Inches	
	Min	Max	Min	Max
A		8.38		.330
∅B	0.64	0.89	.025	.035
∅B1	2.51	2.77	.099	.109
D	36.70	36.96	1.445	1.455
D1	48.01	48.51	1.890	1.910
D2	42.93	43.43	1.690	1.710
e1	7.37	7.87	.290	.310
e2	12.45	12.95	.490	.510
e3	17.53	18.03	.690	.710
e4	22.61	23.11	.890	.910
E	28.32	28.58	1.115	1.125
EA	20.07	20.57	.790	.810
EB	23.11	23.62	.910	.930
F	1.22	1.52	.048	.060
L	6.35	6.86	.250	.270
R1	2.29	2.79	.090	.110
R2	2.92	3.43	.115	.135
R3	2.03	2.54	.080	.100
S	5.08	5.33	.200	.210

NOTES:

1. The U.S. government preferred system of measurement is the metric SI. This item was designed using inch-pound units of measurement. In case of problems involving conflicts between the metric and inch-pound units, the inch-pound units shall rule.
2. Case outline Z weight: 38 grams maximum.

FIGURE 1. Case outline(s) – Continued.

STANDARD MICROCIRCUIT DRAWING DEFENSE SUPPLY CENTER COLUMBUS COLUMBUS, OHIO 43216-5000	SIZE A		5962-91600
		REVISION LEVEL B	SHEET 9

[查询"5962-9160001HXA"供应商](#)

Device type	01
Case outlines	X and Z
Terminal number	Terminal symbol
1	Inhibit
2	No connection
3	Output return
4	Output
5	No connection
6	Case ground
7	Input return
8	Input

FIGURE 2. Terminal connections.

STANDARD MICROCIRCUIT DRAWING DEFENSE SUPPLY CENTER COLUMBUS COLUMBUS, OHIO 43216-5000	SIZE A		5962-91600
		REVISION LEVEL B	SHEET 10

TABLE II. Electrical test requirements.

MIL-PRF-38534 test requirements	Subgroups (in accordance with MIL-PRF-38534, group A test table)
Interim electrical parameters	---
Final electrical parameters	1*, 2, 3, 4, 5, 6
Group A test requirements	1, 2, 3, 4, 5, 6
Group C end-point electrical parameters	1, 4
MIL-STD-883, group E end-point electrical parameters for RHA devices	Subgroups** (in accordance with method 5005, group A test table)

* PDA applies to subgroup 1.

** When applicable to this standard microcircuit drawing, the subgroups shall be defined.

4.2 Screening. Screening shall be in accordance with MIL-PRF-38534. The following additional criteria shall apply:

a. Burn-in test, method 1015 of MIL-STD-883.

(1) Test condition A, B, C, or D. The test circuit shall be maintained by the manufacturer under document revision level control and shall be made available to either DSCC-VA or the acquiring activity upon request. Also, the test circuit shall specify the inputs, outputs, biases, and power dissipation, as applicable, in accordance with the intent specified in test method 1015 of MIL-STD-883.

(2) T_C as specified in accordance with table I of method 1015 of MIL-STD-883.

b. Interim and final electrical test parameters shall be as specified in table II herein, except interim electrical parameter tests prior to burn-in are optional at the discretion of the manufacturer.

4.3 Conformance and periodic inspections. Conformance inspection (CI) and periodic inspection (PI) shall be in accordance with MIL-PRF-38534 and as specified herein.

4.3.1 Group A inspection (CI). Group A inspection shall be in accordance with MIL-PRF-38534 and as follows:

a. Tests shall be as specified in table II herein.

b. Subgroups 7, 8, 9, 10, and 11 shall be omitted.

4.3.2 Group B inspection (PI). Group B inspection shall be in accordance with MIL-PRF-38534.

STANDARD MICROCIRCUIT DRAWING DEFENSE SUPPLY CENTER COLUMBUS COLUMBUS, OHIO 43216-5000	SIZE A		5962-91600
		REVISION LEVEL B	SHEET 11

4.3.3 Group C inspection (PI). Group C inspection shall be in accordance with MIL-PRF-38534 and as follows:

[查询"5962-91600A/HXA"供应商](#)
End-point electrical parameters shall be as specified in table II herein.

b. Steady-state life test, method 1005 of MIL-STD-883.

- (1) Test condition A, B, C, or D. The test circuit shall be maintained by the manufacturer under document revision level control and shall be made available to either DSCC-VA or the acquiring activity upon request. Also, the test circuit shall specify the inputs, outputs, biases, and power dissipation, as applicable, in accordance with the intent specified in test method 1005 of MIL-STD-883.
- (2) T_C as specified in accordance with table I of method 1005 of MIL-STD-883.
- (3) Test duration: 1,000 hours, except as permitted by method 1005 of MIL-STD-883.

4.3.4 Group D inspection (PI). Group D inspection shall be in accordance with MIL-PRF-38534.

4.3.5 Group E inspection. Group E inspection is required only for parts intended to be marked as radiation hardness assured (see 3.5 herein). RHA levels shall be M, D, R, and H. RHA quality conformance inspection sample tests shall be performed at the RHA level specified in the acquisition document.

- a. RHA tests for levels M, D, R, and H shall be performed through each level to determine at what levels the devices meet the RHA requirements. These RHA tests shall be performed for initial qualification and after design or process changes which may affect the RHA performance of the device.
- b. End-point electrical parameters shall be as specified in table II herein.
- c. Prior to total dose irradiation, each selected sample shall be assembled in its qualified package. It shall pass the specified group A electrical parameters in table I for subgroups specified in table II herein.
- d. The devices shall be subjected to radiation hardness assured tests as specified in MIL-PRF-38534 for RHA level being tested, and meet the postirradiation end-point electrical parameter limits as defined in table I at $T_A = +25^{\circ}C \pm 5$ percent, after exposure.
- e. Prior to and during total dose irradiation testing, the devices shall be biased to establish a worst case condition as specified in the radiation exposure circuit.
- f. For device classes H and K, subgroups 1 and 2 in table V, method 5005 of MIL-STD-883 shall be tested as appropriate for device construction.
- g. When specified in the purchase order or contract, a copy of the RHA delta limits shall be supplied.

5. PACKAGING

5.1 Packaging requirements. The requirements for packaging shall be in accordance with MIL-PRF-38534.

6. NOTES

6.1 Intended use. Microcircuits conforming to this drawing are intended for use for Government microcircuit applications (original equipment), design applications, and logistics purposes.

6.2 Replaceability. Microcircuits covered by this drawing will replace the same generic device covered by a contractor-prepared specification or drawing.

STANDARD MICROCIRCUIT DRAWING DEFENSE SUPPLY CENTER COLUMBUS COLUMBUS, OHIO 43216-5000	SIZE A		5962-91600
		REVISION LEVEL B	SHEET 12

6.3 Configuration control of SMD's. All proposed changes to existing SMD's will be coordinated with the users of record for the individual documents. This coordination will be accomplished in accordance with MIL-STD-973 using DD Form 1692, Engineering Change Proposal.

[查询"5962-9160001HXA"供应商](#)

6.4 Record of users. Military and industrial users shall inform Defense Supply Center Columbus when a system application requires configuration control and the applicable SMD. DSCC will maintain a record of users and this list will be used for coordination and distribution of changes to the drawings. Users of drawings covering microelectronic devices (FSC 5962) should contact DSCC-VA, telephone (614) 692-0526.

6.5 Comments. Comments on this drawing should be directed to DSCC-VA, Columbus, Ohio 43216-5000, or telephone (614) 692-0512.

6.6 Sources of supply. Sources of supply are listed in QML-38534. The vendors listed in QML-38534 have submitted a certificate of compliance (see 3.7 herein) to DSCC-VA and have agreed to this drawing.

STANDARD MICROCIRCUIT DRAWING DEFENSE SUPPLY CENTER COLUMBUS COLUMBUS, OHIO 43216-5000	SIZE A		5962-91600
		REVISION LEVEL B	SHEET 13

DATE: 99-02-03

Approved sources of supply for SMD 5962-91600 are listed below for immediate acquisition information only and shall be added to QML-38534 during the next revision. QML-38534 will be revised to include the addition or deletion of sources. The vendors listed below have agreed to this drawing and a certificate of compliance has been submitted to and accepted by DSCC-VA. This bulletin is superseded by the next dated revision of QML-38534.

Standard microcircuit drawing PIN <u>1/</u>	Vendor CAGE number	Vendor similar PIN <u>2/</u>
5962-9160001HXA	52467	AHF2805S/CH
5962-9160001HZA	52467	AHF2805SF/CH

- 1/ The lead finish shown for each PIN representing a hermetic package is the most readily available from the manufacturer listed for that part. If the desired lead finish is not listed contact the vendor to determine its availability.
- 2/ Caution. Do not use this number for item acquisition. Items acquired to this number may not satisfy the performance requirements of this drawing.

Vendor CAGE number

52467

Vendor name and address

Lambda Advanced Analog Incorporated
 2270 Martin Avenue
 Santa Clara, Ca 95050-2781

The information contained herein is disseminated for convenience only and the Government assumes no liability whatsoever for any inaccuracies in the information bulletin.