



MMBD4448H

Surface Mount Switching Diode



Voltage Range
80 Volts
350m Watts Power Dissipation

Features

- ✧ Fast switching speed
- ✧ Surface mount package ideally suited for automatic insertion
- ✧ For general purpose switching applications
- ✧ High conductance

Mechanical Data

- ✧ Case: SOT-23, Molded plastic
- ✧ Terminals: Solderable per MIL-STD-202, Method 208
- ✧ Polarity: See diagram
- ✧ Marking: KA3
- ✧ Weight: 0.008 gram (approx.)

SOT-23

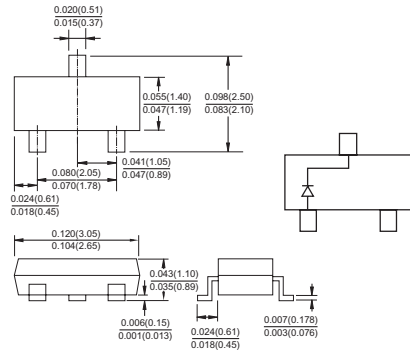

Maximum Ratings and Electrical Characteristics

Rating at 25°C ambient temperature unless otherwise specified.

Maximum Ratings

Type Number	Symbol	MMBD4448H	Units
Non-Repetitive Peak Reverse Voltage	VRM	100	V
Peak Repetitive Reverse Voltage	VRRM	80	V
Working Peak Reverse Voltage	VRWM		
DC Blocking Voltage	VR		
RMS Reverse Voltage	VR(RMS)	57	V
Forward Continuous Current (Note 1)	IFM	500	mA
Average Rectifier Output Current (Note 1)	Io	250	mA
Non-Repetitive Peak Forward Surge Current @ t=1.0uS @ t=1.0S	IFSM	4.0 2.0	A
Power Dissipation (Note 1)	Pd	350	mW
Thermal Resistance Junction to Ambient Air (Note 1)	R θ JA	357	K/W
Operating and Storage Temperature Range	T _J , T _{STG}	-65 to + 150	°C

Electrical Characteristics

Type Number	Symbol	Min	Max	Units
Reverse Breakdown Voltage (Note 2) IR=2.5uA	V(BR)	80	—	V
Forward Voltage IF=5.0mA IF= 10mA IF =100mA IF=150mA	VF	0.62	0.72 0.855 1.0 1.25	V
Peak Reverse Current (Note 2) VR=75V VR=75V, Tj=150°C VR=25V, Tj=150°C VR=20V	IR	—	100 50 30 25	uA nA
Junction Capacitance VR=0.6V, f=1.0MHz	Cj	—	3.5	pF
Reverse Recovery Time VR=6V, IF=5mA	trr	—	4.0	nS

Notes: 1. Valid Provided that Terminals are Kept at Ambient Temperature.

2. tp < 300uS, Duty Cycle < 2%.

RATINGS AND CHARACTERISTIC CURVES (MMBD4448H)

