

**DESCRIPTION**

These low capacitance diode arrays are multiple, discrete, isolated junctions fabricated by a planar process and mounted in a 14-PIN package for use as steering diodes protecting up to eight I/O ports from ESD, EFT, or surge by directing them to the positive side of the power supply line and to ground (see figure 1). An external TVS diode may be added between the positive supply line and ground to prevent overvoltage on the supply rail. They may also be used in fast switching core-driver applications. This includes computers and peripheral equipment such as magnetic cores, thin-film memories, plated-wire memories, etc., as well as decoding or encoding applications. These arrays offer many advantages of integrated circuits such as high-density packaging and improved reliability. This is a result of fewer pick and place operations, smaller footprint, smaller weight, and elimination of various discrete packages that may not be as user friendly in PC board mounting.

**IMPORTANT:** For the most current data, consult MICROSEMI's website: <http://www.microsemi.com>

**APPEARANCE**

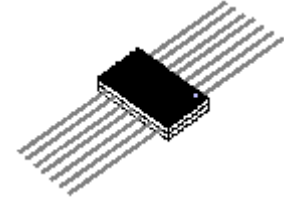

14-PIN Ceramic Flat Pack

**FEATURES**

- Hermetic Ceramic Package
- Isolated Diodes To Eliminate Cross-Talk Voltages
- High Breakdown Voltage  $V_{BR} > 60$  V at 10  $\mu$ A
- Low Leakage  $I_R < 100$ nA at 40 V
- Low Capacitance  $C < 8.0$  pF
- Options for screening in accordance with MIL-PRF-19500/474 for JAN, JANTX, JANTXV, and JANS are available by adding MQ, MX, MV, or SP prefixes respectively to part numbers. For example, designate MX5774A for a JANTX screen.

**APPLICATIONS / BENEFITS**

- High Frequency Data Lines
- RS-232 & RS-422 Interface Networks
- Ethernet: 10 Base T
- Computer I/O Ports
- LAN
- Switching Core Drivers
- IEC 61000-4 Compatible (see circuit in figure 1)  
61000-4-2 ESD: Air 15 kV, contact 8 kW  
61000-4-4 (EFT): 40 A – 5/50 ns  
61000-4-5 (surge): 12 A 8/20  $\mu$ s

**MAXIMUM RATINGS**

- Reverse Breakdown Voltage of 60 Vdc (Note 1 & 2)
- Continuous Forward Current of 300 mA dc (Note 1 & 3)
- Peak Surge Current (tp=1/120 s) of 500 mA dc (Note 1)
- 400 mW Power Dissipation per Junction @ 25°C
- 500 mW Power Dissipation per Package @ 25°C (Note 4)
- Operating Junction Temperature range –65 to +150°C
- Storage Temperature range of –65 to +150°C

**NOTE 1:** Each Diode

**NOTE 2:** Pulsed:  $P_W = 100$  ms max.; duty cycle  $\leq 20\%$

**NOTE 3:** Derate at 2.4 mA/°C above +25°C

**NOTE 4:** Derate at 4.0 mW/°C above +25°C

**MECHANICAL AND PACKAGING**

- 14-PIN Ceramic Flat Pack
- Weight 0.29 grams (approximate)
- Marking: Logo, part number, date code and dot identifying pin #1
- Carrier Tubes; 19 pcs (standard)

PART NUMBER	MAXIMUM FORWARD VOLTAGE	MAXIMUM REVERSE CURRENT	MAXIMUM CAPACITANCE (PIN TO PIN)	MAXIMUM FORWARD RECOVERY TIME	MAXIMUM REVERSE RECOVERY TIME
	$V_{F1}$ $I_F = 100$ mA (Note 1) Vdc	$I_{R1}$ $V_R = 40$ V $\mu$ Adc	$C_t$ $V_R = 0$ V $F = 1$ MHz pF	$t_{fr}$ $I_F = 500$ mA ns	$t_{rr}$ $I_F = I_R = 200$ mA $i_{rr} = 20$ mA $R_L = 100$ ohms ns
5774A	1	0.1	8.0	40	20

**NOTE 1:** Pulsed:  $P_W = 300$   $\mu$ s +/- 50  $\mu$ s, duty cycle  $\leq 2\%$ , 90  $\mu$ s after leading edge.

**SYMBOLS & DEFINITIONS**

Symbol	DEFINITION
$V_{BR}$	Minimum Breakdown Voltage: The minimum voltage the device will exhibit at a specified current.
$V_F$	Maximum Forward Voltage: The maximum forward voltage the device will exhibit at a specified current.
$I_R$	Maximum Leakage Current: The maximum leakage current that will flow at the specified voltage and temperature.
$C_t$	Capacitance: The capacitance of the TVS as defined @ 0 volts at a frequency of 1 MHz and stated in picofarads.

**SCHEMATIC**

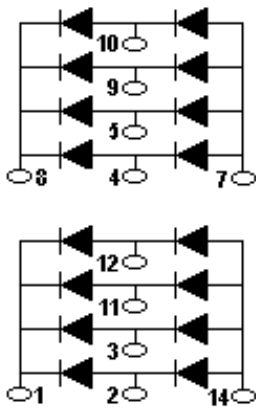

**PACKAGE DIMENSIONS**

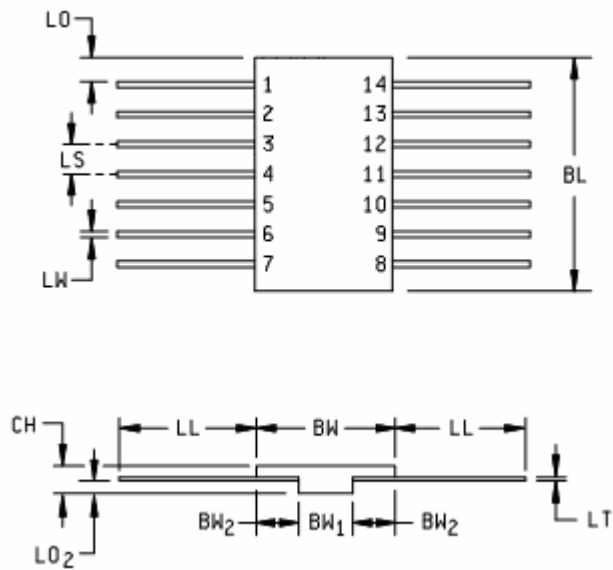

**CIRCUIT**

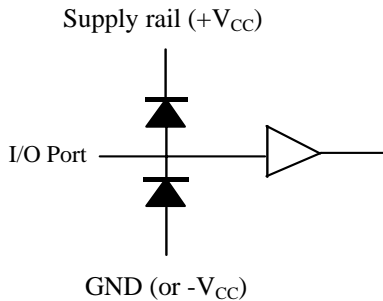

**Steering Diode Application**

**FIGURE 1**

Symbol	Inches		Millimeters	
	Min	Max	Min	Max
BL		.390		9.91
BW	.235	.260	5.97	6.60
CH	.045	.095	1.14	2.41
LL	.250	.370	6.35	9.40
LO	.005		0.13	
LO <sub>2</sub>	.026	.045	0.66	1.14
LS	.050 BSC		1.27 BSC	
LT	.003	.006	0.08	0.15
LU		.280		7.11
LW	.010	.019	0.25	0.48