

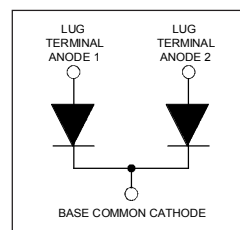

301CNQ...PbF SERIES

SCHOTTKY RECTIFIER

300 Amp



Major Ratings and Characteristics

Characteristics	Values	Units
$I_{F(AV)}$ Rectangular waveform	300	A
V_{RRM} range	40-45	V
I_{FSM} @tp = 5 μ s sine	16,000	A
V_F @150Apk, $T_J=125^\circ\text{C}$ (per leg)	0.59	V
T_J range	-55 to 175	$^\circ\text{C}$

Description/ Features

The 301CNQ.. center tap Schottky rectifier module series has been optimized for low reverse leakage at high temperature. The proprietary barrier technology allows for reliable operation up to 175 $^\circ\text{C}$ junction temperature. Typical applications are in high current switching power supplies, plating power supplies, UPS systems, converters, free-wheeling diodes, welding, and reverse battery protection.

- 175 $^\circ\text{C}$ T_J operation
- Center tap module
- Low forward voltage drop
- High frequency operation
- Guard ring for enhanced ruggedness and long term reliability
- Lead-Free

Case Styles



TO-244

301CNQ...PbF Series

Bulletin PD-21104 12/05



Voltage Ratings

Part number	301CNQ040PbF	301CNQ045PbF
V _R Max. DC Reverse Voltage (V)	40	45
V _{RWM} Max. Working Peak Reverse Voltage (V)		

Absolute Maximum Ratings

Parameters	301CNQ	Units	Conditions
I _{F(AV)} Max. Average Forward Current * See Fig. 5	300 150	A	50% duty cycle @ T _C = 81 °C, rectangular wave form
I _{FSM} Max. Peak One Cycle Non-Repitive Surge Current (Per Leg) * See Fig. 7	16,000 3200	A	5µs Sine or 3µs Rect. pulse 10ms Sine or 6ms Rect. pulse
E _{AS} Non-Repitive Avalanche Energy (Per Leg)	202	mJ	T _J = 25 °C, I _{AS} = 21 Amps, L = 1 mH
I _{AR} Repetitive Avalanche Current (Per Leg)	30	A	Current decaying linearly to zero in 1 µsec Frequency limited by T _J max. V _A = 1.5 x V _R typical

Electrical Specifications

Parameters	301CNQ	Units	Conditions
V _{FM} Max. Forward Voltage Drop (Per Leg) * See Fig. 1 (1)	0.69 0.90 0.59 0.76	V	@ 150A @ 300A @ 150A @ 300A
I _{RM} Max. Reverse Leakage Current (Per Leg) * See Fig. 2 (1)	10 90	mA	T _J = 25 °C T _J = 125 °C
C _T Max. Junction Capacitance (Per Leg)	5200	pF	V _R = 5V _{DC} (test signal range 100Khz to 1Mhz) 25°C
L _S Typical Series Inductance (Per Leg)	7.0	nH	From top of terminal hole to mounting plane
dv/dt Max. Voltage Rate of Change	10,000	V/ µs	(Rated V _R)

(1) Pulse Width < 300µs, Duty Cycle <2%

Thermal - Mechanical Characteristics

Parameters	Min	Typ	Max	Units
T _J Max. Junction Temperature Range	- 55	-	175	°C
T _{Stg} Max. Storage Temperature Range	- 55	-	175	
R _{thJC} Thermal Resistance, Junction to Case	-	-	0.28	°C/W
Thermal Resistance, Junction to Case	-	-	0.14	K/W
R _{thCS} Thermal Resistance, Case to Heatsink	-	0.10	-	
Wt Weight	-	68 (2.4)	-	g (oz)
Mounting Torque	35.4 (4)	-	53.1 (6)	lb*in
Mounting Torque Center Hole	30 (3.4)	-	40 (4.6)	(Nm)
Terminal Torque	30 (3.4)	-	44.2 (5)	
Vertical Pull	-	-	80	lbf.in
2 inch Lever Pull	-	-	35	

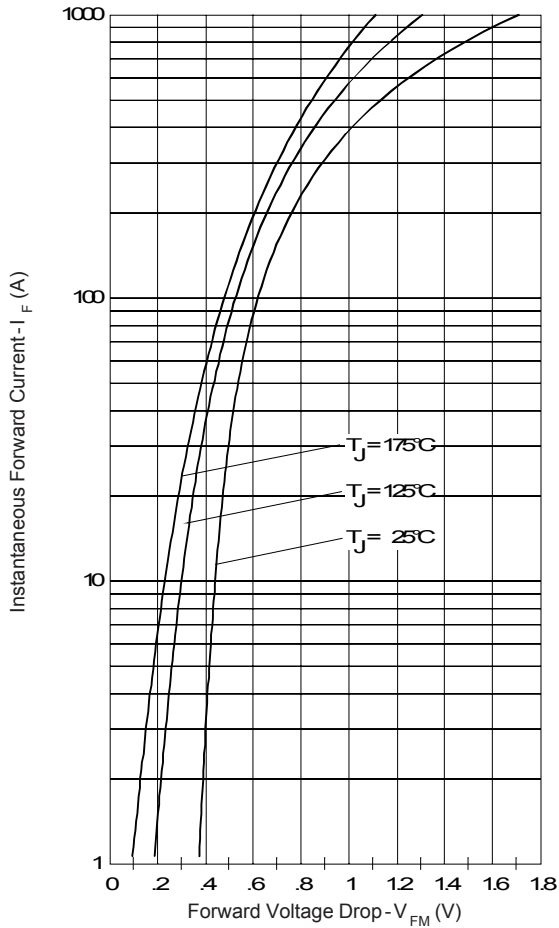

Fig. 1 - Max. Forward Voltage Drop Characteristics (Per Leg)

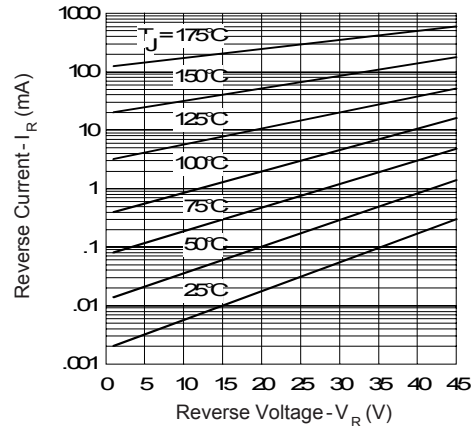

Fig. 2 - Typical Values Of Reverse Current Vs. Reverse Voltage (Per Leg)

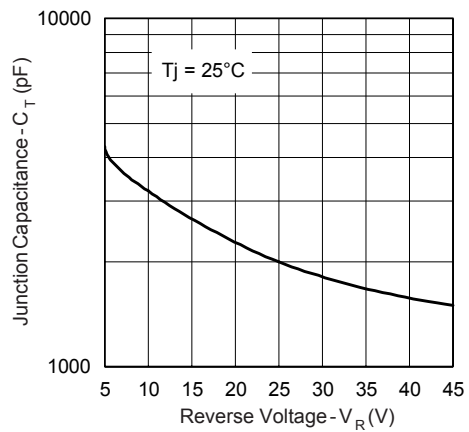

Fig. 3 - Typical Junction Capacitance Vs. Reverse Voltage (Per Leg)

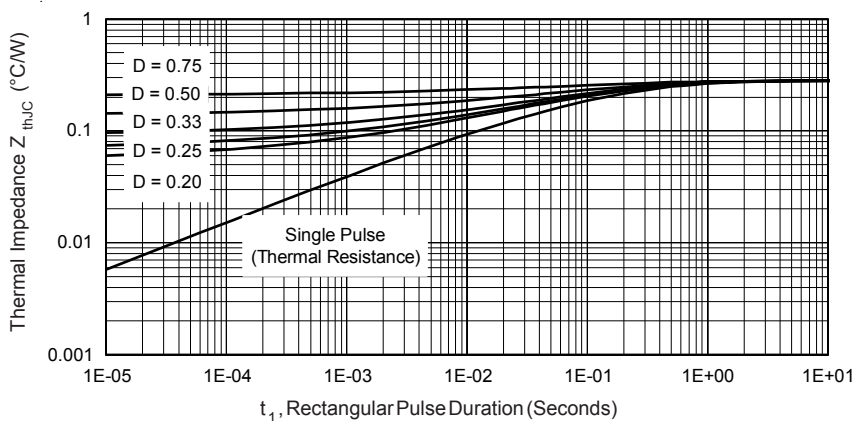

Fig. 4 - Max. Thermal Impedance Z_{thJC} Characteristics (Per Leg)

301CNQ...PbF Series

Bulletin PD-21104 12/05

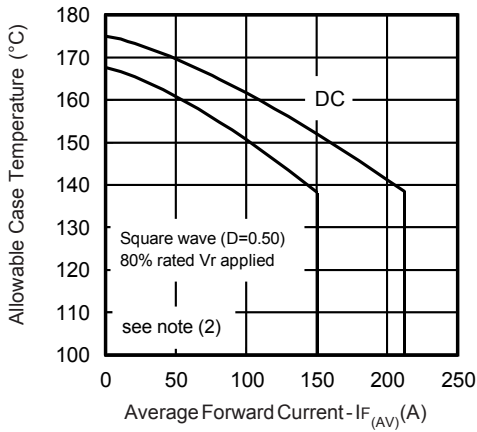

Fig. 5 - Max. Allowable Case Temperature Vs. Average Forward Current (Per Leg)

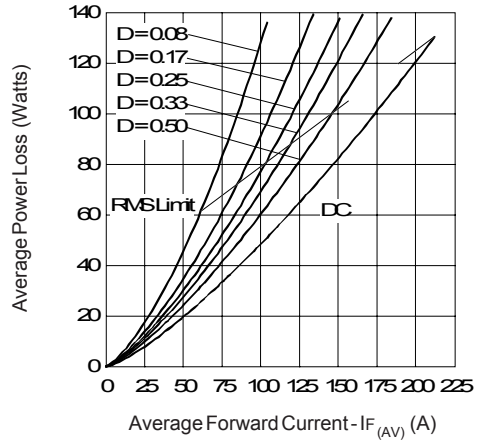

Fig. 6 - Forward Power Loss Characteristics (Per Leg)

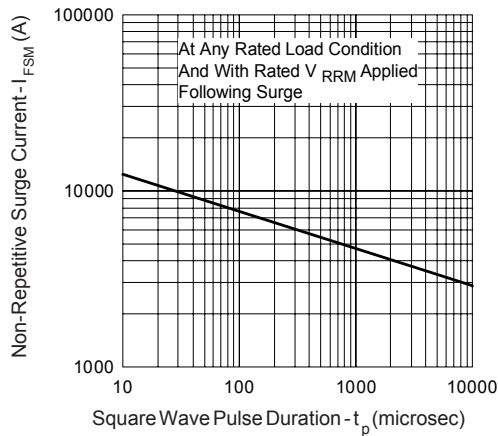

Fig. 7 - Max. Non-Repetitive Surge Current (Per Leg)

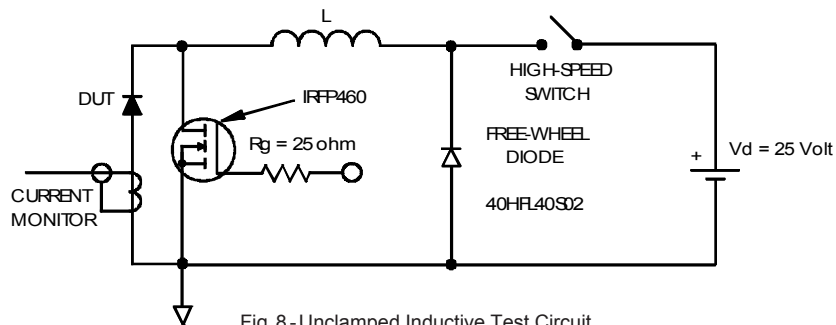

Fig. 8 - Unclamped Inductive Test Circuit

(2) Formula used: $T_c = T_j - (Pd + Pd_{REV}) \times R_{thJC}$:

Pd = Forward Power Loss = $I_{F(AV)} \times V_{FM} @ (I_{F(AV)} / D)$ (see Fig. 6);

Pd_{REV} = Inverse Power Loss = $V_{R1} \times I_R (1 - D)$; $I_R @ V_{R1} = 80\%$ rated V_R

Outline Table

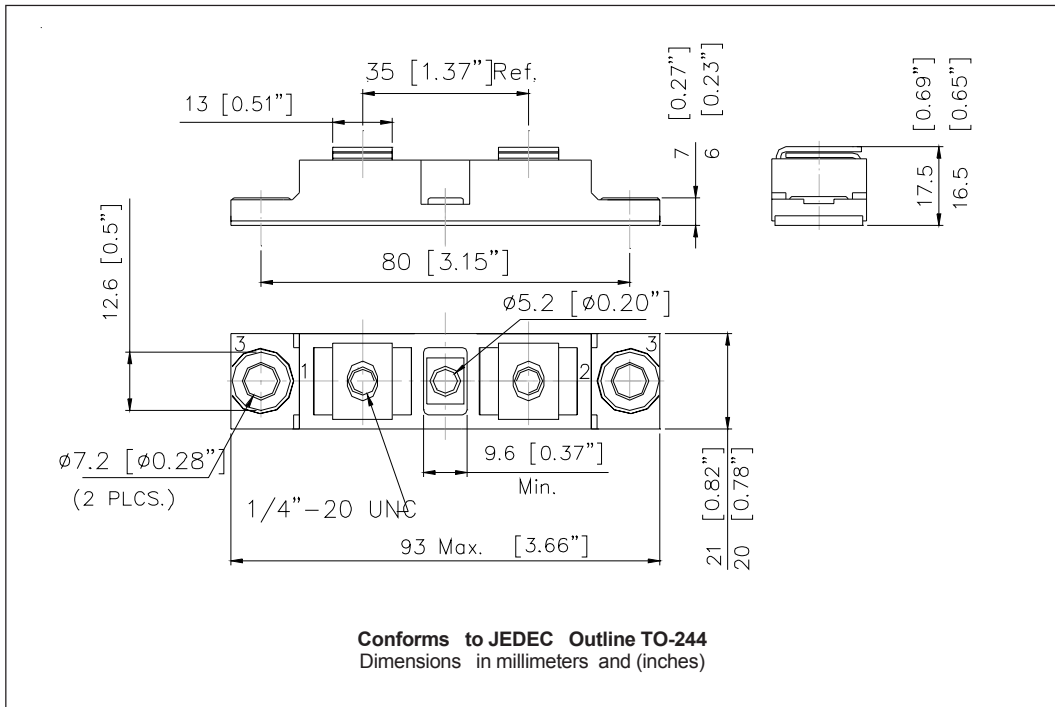

Ordering Information Table

Device Code						
30	1	C	N	Q	045	PbF
①	②	③	④	⑤	⑥	⑦
1	- Average Current Rating (x 10)					
2	- Product Silicon Identification					
3	- C = Circuit Configuration					
4	- N = NOT Isolated					
5	- Q = Schottky Rectifier Diode					
6	- Voltage Ratings					
7	- Lead-Free					

040 = 40V
045 = 45V

301CNQ...PbF Series

Bulletin PD-21104 12/05

International
IR Rectifier

Data and specifications subject to change without notice.
This product has been designed and qualified for Industrial Level and Lead-Free.
Qualification Standards can be found on IR's Web site.

International
IR Rectifier

IR WORLD HEADQUARTERS: 233 Kansas St., El Segundo, California 90245, USA Tel: (310) 252-7105
TAC Fax: (310) 252-7309

Visit us at www.irf.com for sales contact information. 12/05