

# PNP SILICON POWER TRANSISTOR 2SA1486

**DESCRIPTION** The 2SA1486 is designed for use in high speed and high voltage switching.  
It is suitable for switching regulators, DC-DC converters and ultrasonic appliance applications.

- FEATURES**
- High speed switching
  - High Voltage

**ABSOLUTE MAXIMUM RATINGS**

<b>Maximum Temperatures</b>	
Storage Temperature .....	-55 to +150 °C
Junction Temperature .....	150 °C Maximum
<b>Maximum Power Dissipation (T<sub>C</sub> = 25 °C)</b>	
Total Power Dissipation .....	15 W
<b>Maximum Voltage and Currents (T<sub>a</sub> = 25 °C)</b>	
V <sub>CBO</sub> Collector to Base Voltage .....	-600 V
V <sub>CEO</sub> Collector to Emitter Voltage ..	-600 V
V <sub>EBO</sub> Emitter to Base Voltage .....	-7.0 V
I <sub>C(DC)</sub> Collector Current (DC) .....	-1.0 A
I <sub>C(pulse)</sub> Collector Current (Pulse)* ..	-2.0 A
*PW ≤ 300 μs, Duty Cycle ≤ 10 %	

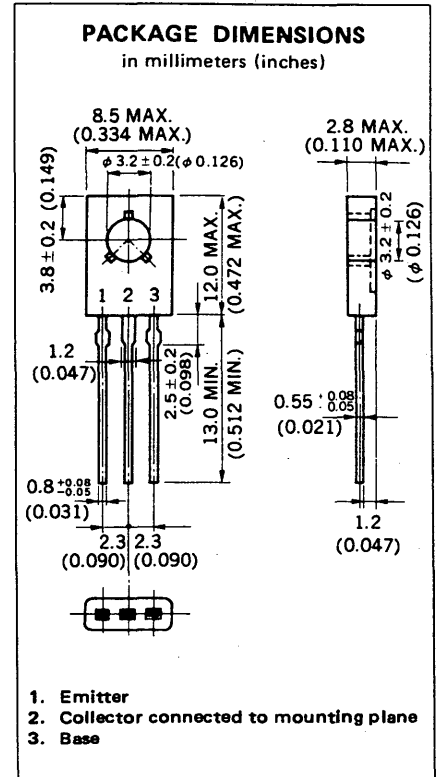

**ELECTRICAL CHARACTERISTICS (T<sub>a</sub> = 25 °C)**

SYMBOL	CHARACTERISTIC	MIN.	TYP.	MAX.	UNIT	TEST CONDITIONS
t <sub>on</sub>	Turn On Time		0.1	0.5	μs	I <sub>C</sub> = -0.5 A, I <sub>B1</sub> = -I <sub>B2</sub> = -0.1 A R <sub>L</sub> = 500 Ω, V <sub>CC</sub> = -250 V
t <sub>stg</sub>	Storage Time		3.5	5.0	μs	
t <sub>f</sub>	Fall Time		0.08	0.5	μs	
h <sub>FE1</sub> **	DC Current Gain	30		120	-	V <sub>CE</sub> = -5.0 V, I <sub>C</sub> = -0.1 A
h <sub>FE2</sub> **	DC Current Gain	5			-	V <sub>CE</sub> = -5.0 V, I <sub>C</sub> = -0.5 A
V <sub>CE(sat)</sub> **	Collector Saturation Voltage			-1.0	V	I <sub>C</sub> = -0.3 A, I <sub>B</sub> = -0.06 A
V <sub>BE(sat)</sub> **	Base Saturation Voltage			-1.2	V	I <sub>C</sub> = -0.3 A, I <sub>B</sub> = -0.06 A
I <sub>CBO</sub>	Collector Cutoff Current			-10	μA	V <sub>CB</sub> = -600 V, I <sub>E</sub> = 0
I <sub>EBO</sub>	Emitter Cutoff Current			-10	μA	V <sub>EB</sub> = -7.0 V, I <sub>C</sub> = 0

\*\* Pulsed: PW ≤ 350 μs, Duty Cycle ≤ 2 %

**Classification of h<sub>FE1</sub>**

Rank	M	L	K
Range	30 to 60	40 to 80	60 to 120

Test Conditions: V<sub>CE</sub> = -5.0 V, I<sub>C</sub> = -0.1 A

TYPICAL CHARACTERISTICS ( $T_a = 25^\circ\text{C}$ )

