

# LQ104S1DG21

## TFT-LCD Module

(Model No.: LQ104S1DG21)

Spec No.: LD-14304  
Issue Date: April 4, 2002

---

PREPARED BY :      DATE	<b>SHARP</b>	SPEC No. LD-14304
<a href="#">查询LQ104S1DG21供应商</a>		FILE No.
		ISSUE : Apr.10.2002
		PAGE : 15 pages
	AVC LIQUID CRYSTAL DISPLAY GROUP SHARP CORPORATION	APPLICABLE GROUP AVC LIQUID CRYSTAL DISPLAY GROUP
	<b>SPECIFICATION</b>	

DEVICE SPECIFICATION FOR  
**TFT-LCD Module**  
 MODEL No.  
**LQ104S1DG21**

CUSTOMER'S APPROVAL

DATE \_\_\_\_\_

BY \_\_\_\_\_

PRESENTED

BY *Makoto Takeda*

M. TAKEDA  
 Department General Manager  
 Development Engineering Department II  
 AVC LIQUID CRYSTAL DISPLAY Division  
 AVC LIQUID CRYSTAL DISPLAY GROUP  
 SHARP CORPORATION



## 1. Application

This specifications applies to color TFT-LCD module, LQ104S1DG21.

### [查询"LQ104S1DG21"供应商](#)

~~These specifications sheets~~ are the proprietary product of SHARP CORPORATION("SHARP) and include materials protected under copyright of SHARP. Do not reproduce or cause any third party to reproduce them in any form or by any means, electronic or mechanical, for any purpose, in whole or in part, without the express written permission of SHARP .

The device listed in these specifications sheets was designed and manufactured for use in general electronic equipment.

In case of using the device for applications such as control and safety equipment for transportation(aircraft, trains, automobiles, etc. ), rescue and security equipment and various safety related equipment which require higher reliability and safety, take into consideration that appropriate measures such as fail-safe functions and redundant system design should be taken .

Do not use the device for equipment that requires an extreme level of reliability, such as aerospace applications, telecommunication equipment(trunk lines), nuclear power control equipment and medical or other equipment for life support .

SHARP assumes no responsibility for any damage resulting from the use of the device which does not comply with the instructions and the precautions specified in these specifications sheets .

Contact and consult with a SHARP sales representative for any questions about this device .

## 2. Overview

This module is a color active matrix LCD module incorporating amorphous silicon TFT (Thin Film Transistor). It is composed of a color TFT-LCD panel, driver ICs, control circuit and power supply circuit and a backlight unit. Graphics and texts can be displayed on a 800 × 3 × 600 dots panel with 262,144 colors by supplying 18 bit data signal (6bit/color), four timing signals, +3.3V or +5V DC supply voltage for TFT-LCD panel driving and supply voltage for backlight.

The TFT-LCD panel used for this module is a low-reflection and higher-color-saturation type. Therefore, this module is also suitable for the multimedia use.

Optimum viewing direction is 6 o'clock.

Backlight-driving DC/AC inverter is not built in this module.

## 3. Mechanical Specifications

Parameter	Specifications	Unit
Display size	26 (10.4") Diagonal	cm
Active area	211.2(H) × 158.4(V)	mm
Pixel format	800(H) × 600(V)	pixel
	(1 pixel = R + G + B dots)	
Pixel pitch	0.264(H) × 0.264(V)	mm
Pixel configuration	R,G,B vertical stripe	
Display mode	Normally white	
Unit outline dimensions *1 (excluding backlight cables)	246.5(W) × 179.4(H) × 15.5max(D) Outline dimensions is shown in Fig.1	mm
Mass	620 max	g
Surface treatment	Anti-glare and hard-coating	

## 4. Input Terminals

## 4-1. TFT-LCD panel driving

Connector name : CN1 Used connector:DF9MA-41P-1V (Hirose Electric Co., Ltd.)

Corresponding connector: DF9-41S-1V,DF9A-41S-1V,DF9B-41S-1V,DF9M-41S-1V

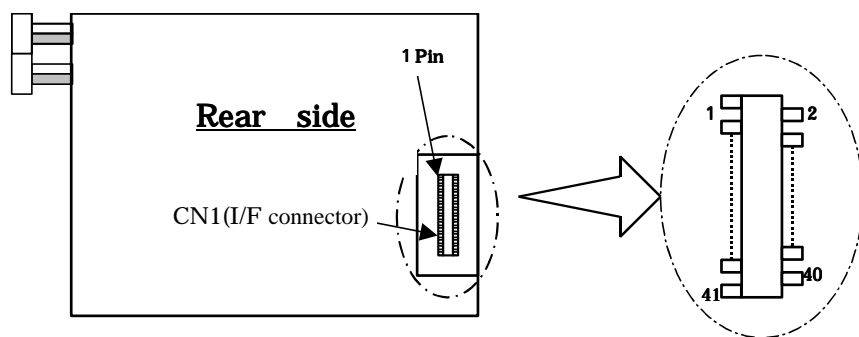

[查询"LQ104S1DG21"供应商](#)

Pin No.	Symbol	Function	Remark
1	GND	-	-
2	CK	Clock signal for sampling each data signal	-
3	GND	-	-
4	Hsync	Horizontal synchronous signal	【Note1】
5	Vsync	Vertical synchronous signal	【Note1】
6	GND	-	-
7	GND	-	-
8	GND	-	-
9	R0	R E D data signal(LSB )	-
10	R1	R E D data signal	-
11	R2	R E D data signal	-
12	GND	-	-
13	R3	R E D data signal	-
14	R4	R E D data signal	-
15	R5	R E D data signal(MSB)	-
16	GND	-	-
17	GND	-	-
18	GND	-	-
19	G0	G R E E N data signal(LSB)	-
20	G1	G R E E N data signal	-
21	G2	G R E E N data signal	-
22	GND	-	-
23	G3	G R E E N data signal	-
24	G4	G R E E N data signal	-
25	G5	G R E E N data signal(MSB)	-
26	GND	-	-
27	GND	-	-
28	GND	-	-
29	B0	B L U E data signal(LSB)	-
30	B1	B L U E data signal	-
31	B2	B L U E data signal	-
32	GND	-	-
33	B3	B L U E data signal	-
34	B4	B L U E data signal	-
35	B5	B L U E data signal(MSB)	-
36	GND	-	-
37	ENAB	Signal to settle the horizontal display position	【Note2】
38	R/L	Horizontal display mode select signal	-
39	Vcc	power supply (+3.3Vor+5.0V)	-
40	Vcc	power supply (+3.3Vor+5.0V)	-
41	U/D	Vertical display mode select signal	-

The shielding case is connected with GND.

【Note1】 The polarity of both synchronous signals are negative.

【Note2】 The horizontal display start timing is settled in accordance with a rising timing of ENAB signal. In case ENAB is fixed "Low", the horizontal start timing is determined as described in 7-2. Don't keep ENAB " High" during operation.

【Note3】R/L=High, U/D=Low

R/L=Low, U/D=Low

Please do not use this terminal by “open”.

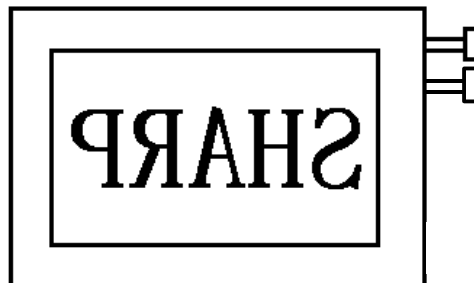
[查询"LQ104S1DG21"供应商](#)

【Note4】R/L=High, U/D=High

R/L=Low, U/D=High

Please do not use this terminal by “open”.

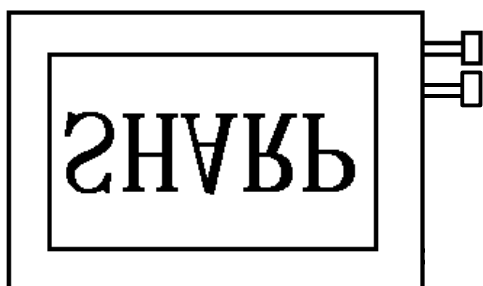

## 4-2. Backlight driving

Connector name :CN2、CN3

Used connector : BHR-03VS-1(JST)

Corresponding connector :SM02(8.0)B-BHS(JST)

Pin no.	Symbol	Function	Cable color
1	V <sub>HIGH</sub>	Power supply for lamp (High voltage side)	Pink
2	NC	This is electrically opened.	
3	V <sub>LOW</sub>	Power supply for lamp (Low voltage side)	White

## 5. Absolute Maximum Ratings

Parameter	Symbol	Condition	Ratings	Unit	Remark
Input voltage	V <sub>I</sub>	Ta=25	- 0.3 ~ +5.5	V	【Note1】
+5V supply voltage	V <sub>CC</sub>	Ta=25	0 ~ + 6	V	
Storage temperature	T <sub>stg</sub>	-	-35 ~ 70		
Operating temperature (Ambient)	T <sub>opa</sub>	-	-10 ~ 65		【Note2】

【Note1】CK,R0 ~ R5,G0 ~ G5,B0 ~ B5,Hsync,Vsync,ENAB, R/L, U/L

【Note2】Humidity : 95%RH Max. at Ta 50 .

Maximum wet-bulb temperature at 39 or less at Ta&gt;50 . ( No condensation. )

【Note3】Humidity : 95%RH Max. at Ta 40 .

Maximum wet-bulb temperature at 39 or less at Ta&gt;40 . ( No condensation. )

## 6. Electrical Characteristics

## 6-1.TFT-LCDpanel driving

Ta = 25

[查询"LQ104S1DG21"供应商](#)

Parameter		Symbol	Min.	Typ.	Max.	Unit	Remark
Power Supply	Supply voltage	V <sub>CC</sub>	+3.0	+3.3   +5.0	+5.5	V	【Note1】
	Current dissipation	I <sub>CC</sub>	-	310	450	m A	V <sub>CC</sub> =3.3V 【Note2】
I <sub>CC</sub>		-	330	470	m A	V <sub>CC</sub> =5.0V 【Note2】	
Permissive input ripple voltage		V <sub>RF</sub>	-	-	100	mVp-p	V <sub>CC</sub> =5.0V
Input voltage (Low)		V <sub>IL</sub>	-	-	0.9	V	【Note3】
Input voltage (High)		V <sub>IH</sub>	2.4	-	-	V	
Input current (low)		I <sub>OL1</sub>	-	-	1.0	μ A	V <sub>I</sub> =0V 【Note4】
		I <sub>OL2</sub>	-	-	60.0	μ A	V <sub>I</sub> =0V 【Note5】
Input current (High)		I <sub>OH1</sub>	-	-	1.0	μ A	V <sub>I</sub> =V <sub>CC</sub> 【Note6】
		I <sub>OH2</sub>	-	-	60.0	μ A	V <sub>I</sub> =V <sub>CC</sub> 【Note7】

## 【 NOTE 1 】

V<sub>CC</sub>-turn-on conditions

$$\begin{aligned}
 T1 & 15 \text{ ms} \\
 0 < T2 & 10 \text{ ms} \\
 0 < T3 & 1 \text{ s} \\
 1 \text{ s} < T4 &
 \end{aligned}$$

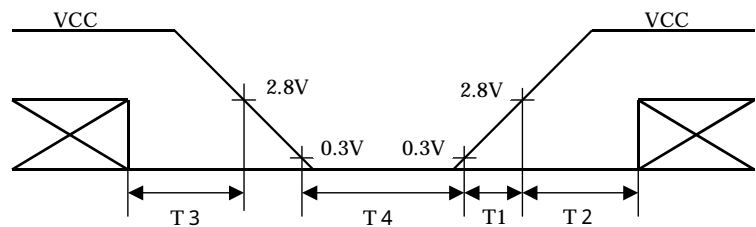
V<sub>CC</sub>-dip conditions

- 1)  $2.7 \text{ V} < V_{CC} < 3.0 \text{ V}$   
 $t_d = 10 \text{ ms}$
- 2)  $V_{CC} < 2.7 \text{ V}$

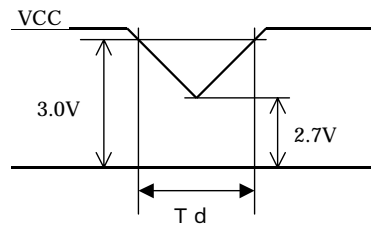
V<sub>CC</sub>-dip condition should also followThe V<sub>CC</sub>-turn-on conditions【Note2】 Typical current situation : 16-gray-bar pattern. V<sub>CC</sub>=+3.3V/+5.0V

【Note3】 CK,R0~R5,G0~G5,B0~B5,Hsync,Vsync,ENAB,R/L,U/D

【Note4】 CK,R0~R5,G0~G5,B0~B5,Hsync,Vsync,ENAB

【Note5】 R/L

【Note6】 CK,R0~R5,G0~G5,B0~B5,Hsync,Vsync

【Note7】 ENAB,U/D

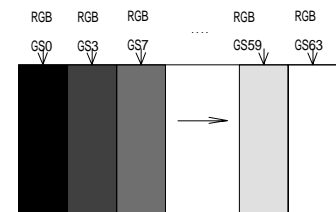



## 6-2. Backlight driving

The backlight system is an edge-lighting type with twin CCFT (Cold Cathode Fluorescent Tube).

The characteristics of single lamp are shown in the following table.

[查询"LQ104S1DG21"供应商](#)

Ta=25

Parameter	Symbol	Min.	Typ.	Max.	Unit	Remark
Lamp current	IL	3.5	6.0	7.0	mArms	【Note1】
Lamp power consumption	PL	-	2.8	-	W	【Note2】
Lamp frequency	FL	40	60	70	KHz	【Note3】
Kick-off voltage	Vs	-	-	1000	Vrms	Ta=25
		-	-	1300	Vrms	Ta =0
		-	-	1450	Vrms	Ta =-10
Lamp life time	LL	50000	-	-	hour	【Note5】 IL=6.0mA
	LL	30000	-	-	hour	【Note5】 IL=7.0mA

【Note1】 Lamp current is measured with current meter for high frequency as shown below.

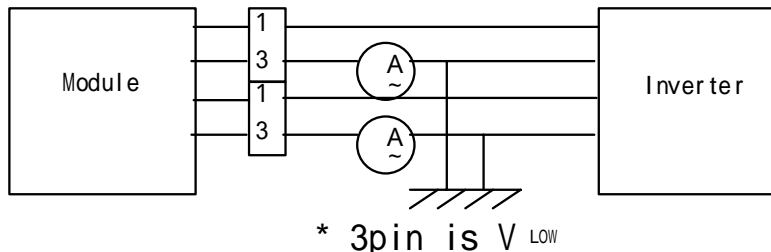

【Note2】 At the condition of  $Y_L = 350\text{cd/m}^2$

【Note3】 Lamp frequency may produce interference with horizontal synchronous frequency, and this may cause beat on the display. Therefore lamp frequency shall be detached as much as possible from the horizontal synchronous frequency and from the harmonics of horizontal synchronous to avoid interference.

【Note4】 The open output voltage of the inverter shall be maintained for more than 1sec; otherwise the lamp may not be turned on.

【Note5】 Since lamp is consumables, the life time written above is referential value and it is not guaranteed in this specification sheet by SHARP.

Lamp life time is defined that it applied either or under this condition.

(Continuous turning on at Ta=25 , IL=6 or 7mArms)

Brightness becomes 50% of the original value under standard condition.

Kick-off voltage at Ta= -10 exceeds maximum value, 1450 Vrms.

In case of operating under lower temp environment, the lamp exhaustion is accelerated and the brightness becomes lower.

(Continuous operating under for around 1 month under lower temp condition may reduce the brightness to half of the original brightness.)

In case of such usage under lower temp environment, periodical lamp exchange is recommended.

【Note6】 The performance of the backlight, for example life time or brightness, is much influenced by the characteristics of the DC-AC inverter for the lamp. When you design or order the inverter, please make sure that a poor lighting caused by the mismatch of the backlight and the inverter (miss-lighting, flicker, etc.) never occur. when you confirm it, the module should be operated in the same condition as it is installed in your instrument.

【Note7】 It is required to have the inverter designed so that to allow the impedance deviation of the two CCFT lamps and the capacity deviation of barast capacitor.

## 7. Timing Characteristics of input signals

Timing diagrams of input signal are shown in Fig.2.

## 7-1. Timing characteristics

Parameter		Symbol	Min.	Typ.	Max.	Unit	Remark
Clock	Frequency	1/Tc	-	40.0	42.0	MHz	-
	High time	Tch	6	-	-	ns	-
	Low time	Tcl	6	-	-	ns	-
	Duty ratio	Th/T	40	50	60	%	-
Data	Setup time	Tds	3	-	-	ns	-
	Hold time	Tdh	5	-	-	ns	-
Horizontal sync. signal	Cycle	TH	20.8	26.4	-	$\mu$ s	-
			832	1056	-	clock	-
	Pulse width	THp	2	128	200	clock	-
Vertical sync. signal	Cycle	TV	628	666	798	line	-
	Pulse width	TVp	2	4	6	line	-
Horizontal display period		THd	800	800	800	clock	-
Hsync-Clock phase difference		THc	0	-	Tc-10	ns	-
Hsync-Vsync phase difference		TVh	0	-	TH-THp	ns	-
Vertical data start position		TVs	23	23	23	line	-

Note) In case of lower frequency, the deterioration of display quality, flicker etc., may be occurred.

## 7-2. Horizontal display position

The horizontal display position is determined by ENAB signal and the input data corresponding to the rising edge of ENAB signal is displayed at the left end of the active area.

Parameter		symbol	Min.	Typ.	Max.	Unit	Remark
Enable signal	Setup time	Tes	5	-	Tc-10	ns	-
	Pulse width	Tep	2	800	TH-10	clock	-
Hsync-Enable signal phase difference		THE	58	88	170	clock	-

Note) When ENAB is fixed "Low", the display starts from the data of C88(clock) as shown in Fig.2.

## 7-3. Vertical display position

The vertical display position, TVs is fixed "23" (line).

## 7-4. Input Data Signals and Display Position on the screen

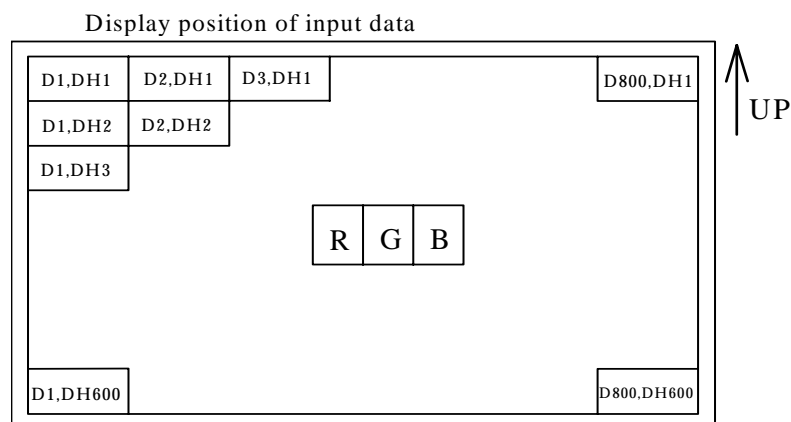



8. Input Signals, Basic Display Colors and Gray Scale of Each Color

	Colors &		Data signal																	
	Gray scale	Gray Scale	R0	R1	R2	R3	R4	R5	G0	G1	G2	G3	G4	G5	B0	B1	B2	B3	B4	B5
<b>Basic Color</b>	Black	-	0	0	0	0	0	0	0	0	0	0	0	0	0	0	0	0	0	0
	Blue	-	0	0	0	0	0	0	0	0	0	0	0	0	1	1	1	1	1	1
	Green	-	0	0	0	0	0	0	1	1	1	1	1	1	0	0	0	0	0	0
	Cyan	-	0	0	0	0	0	0	1	1	1	1	1	1	1	1	1	1	1	1
	Red	-	1	1	1	1	1	1	0	0	0	0	0	0	0	0	0	0	0	0
	Magenta	-	1	1	1	1	1	1	0	0	0	0	0	0	1	1	1	1	1	1
	Yellow	-	1	1	1	1	1	1	1	1	1	1	1	1	0	0	0	0	0	0
	White	-	1	1	1	1	1	1	1	1	1	1	1	1	1	1	1	1	1	1
<b>Gray Scale of Red</b>	Black	GS0	0	0	0	0	0	0	0	0	0	0	0	0	0	0	0	0	0	0
	↑	GS1	1	0	0	0	0	0	0	0	0	0	0	0	0	0	0	0	0	0
	Darker	GS2	0	1	0	0	0	0	0	0	0	0	0	0	0	0	0	0	0	0
	↑	↓				↓					↓						↓			
	↓	↓				↓					↓						↓			
	Brighter	GS61	1	0	1	1	1	1	0	0	0	0	0	0	0	0	0	0	0	0
	↓	GS62	0	1	1	1	1	1	0	0	0	0	0	0	0	0	0	0	0	0
	Red	GS63	1	1	1	1	1	1	0	0	0	0	0	0	0	0	0	0	0	0
<b>Gray Scale of Green</b>	Black	GS0	0	0	0	0	0	0	0	0	0	0	0	0	0	0	0	0	0	0
	↑	GS1	0	0	0	0	0	0	1	0	0	0	0	0	0	0	0	0	0	0
	Darker	GS2	0	0	0	0	0	0	0	1	0	0	0	0	0	0	0	0	0	0
	↑	↓				↓					↓						↓			
	↓	↓				↓					↓						↓			
	Brighter	GS61	0	0	0	0	0	0	1	0	1	1	1	1	0	0	0	0	0	0
	↓	GS62	0	0	0	0	0	0	0	1	1	1	1	1	0	0	0	0	0	0
	Green	GS63	0	0	0	0	0	0	1	1	1	1	1	1	0	0	0	0	0	0
<b>Gray Scale of Blue</b>	Black	GS0	0	0	0	0	0	0	0	0	0	0	0	0	0	0	0	0	0	0
	↑	GS1	0	0	0	0	0	0	0	0	0	0	0	0	1	0	0	0	0	0
	Darker	GS2	0	0	0	0	0	0	0	0	0	0	0	0	0	1	0	0	0	0
	↑	↓				↓					↓						↓			
	↓	↓				↓					↓						↓			
	Brighter	GS61	0	0	0	0	0	0	0	0	0	0	0	0	1	0	1	1	1	1
	↓	GS62	0	0	0	0	0	0	0	0	0	0	0	0	0	1	1	1	1	1
	Blue	GS63	0	0	0	0	0	0	0	0	0	0	0	0	1	1	1	1	1	1

0 :Low level voltage, 1 : High level voltage

Each basic color can be displayed in 64 gray scales from 6 bit data signals. According to the combination of total 18 bit data signals, the 262,144-color display can be achieved on the screen.

Parameter		Symbol	Condition	Min	Typ	Max	Unit	Remark
Viewing Angle Range	Horizontal	21, 22	CR 10	60	70	-	Deg.	【Note1,4】
	Vertical	11		35	40	-	Deg.	
		12		55	70	-	Deg.	
Contrast ratio		CR	=0 °	150	-	-	-	【Note2,4】
			Best Viewing Angle	-	300	-	-	
Response Time	Rise	r	=0 °	-	20	-	m s	【Note3,4】
	Decay	d		-	40	-	m s	
Chromaticity of White		x		-	0.313	-		【Note4】
		y		-	0.329	-		
Luminance of white		Y <sub>L</sub>		280	350	-	cd/m <sup>2</sup>	
White Uniformity		w		-	-	1.45	-	【Note5】
Viewing Angle range as a Brightness Definition	Horizontal	21, 22	50% of the maximum brightness	-	35	-	Deg.	【Note1】 (Reference value )
	Vertical	11		-	25	-	Deg.	
		12		-	30	-	Deg.	

The measurement shall be executed 30 minutes after lighting at rating. (typical condition:L=6.0mArms)

The optical characteristics shall be measured in a dark room or equivalent state with the method shown in Fig.3 below.

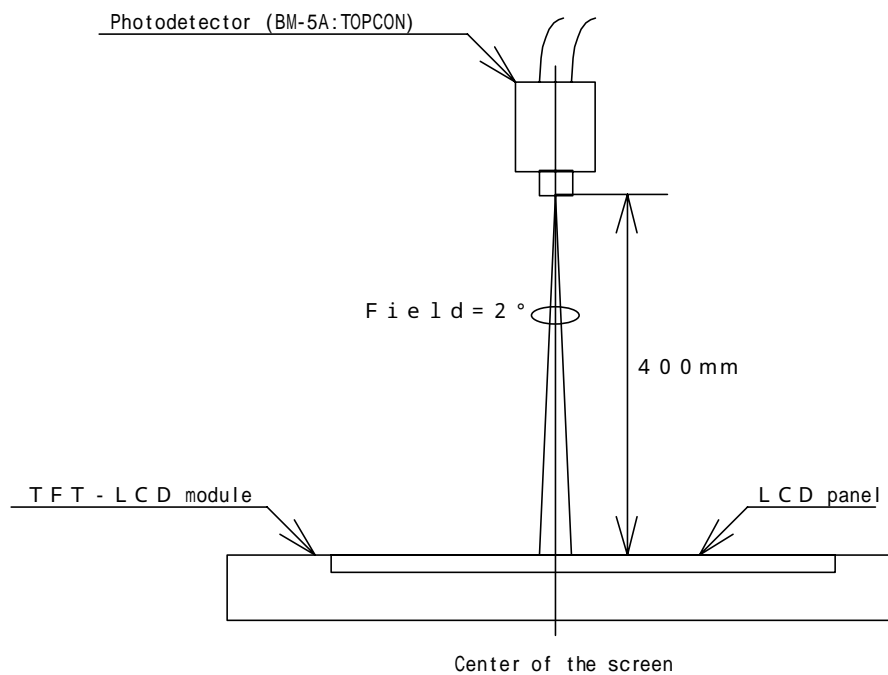
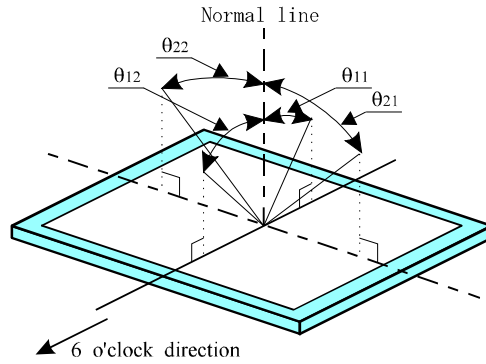

Fig.3 Optical characteristics measurement method

【Note1】 Definitions of viewing angle range:

[查询"LQ104S1DG21"供应商](#)



【Note2】 Definition of contrast ratio:

The contrast ratio is defined as the following.

$$\text{Contrast Ratio (CR)} = \frac{\text{Luminance (brightness) with all pixels white}}{\text{Luminance (brightness) with all pixels black}}$$

【Note3】 Definition of response time:

The response time is defined as the following figure and shall be measured by switching the input signal for "black" and "white" .

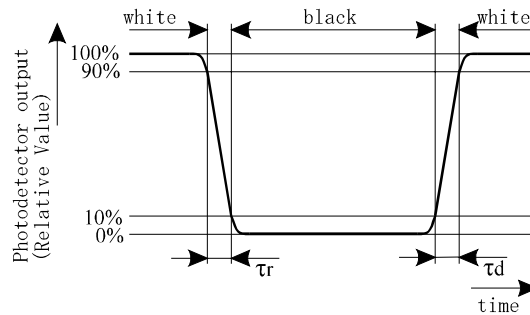

【Note4】 This shall be measured at center of the screen.

【Note5】 Definition of white uniformity:

White uniformity is defined as the following with five measurements (A ~ E).

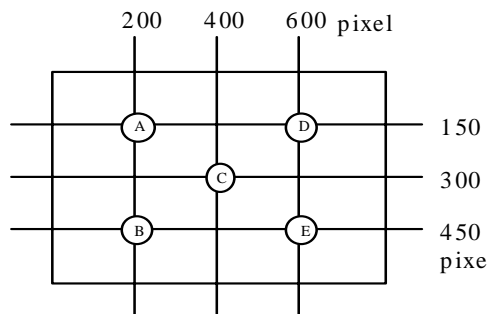

$$w = \frac{\text{Maximum Luminance of five points (brightness)}}{\text{Minimum Luminance of five points (brightness)}}$$

## 10. Display Quantity

The display quality of the color TFT-LCD module shall be in compliance with the Incoming Inspection Standard.

## 11. Handling Precautions

[查询"LQ104S1DG21"供应商](#)

- a) Be sure to turn off the power supply when inserting or disconnecting the cable.
- b) Be sure to design the cabinet so that the module can be installed without any extra stress such as warp or twist.
- c) Since the front polarizer is easily damaged, pay attention not to scratch it.
- d) Wipe off water drop immediately. Long contact with water may cause discoloration or spots.
- e) When the panel surface is soiled, wipe it with absorbent cotton or other soft cloth.
- f) Since the panel is made of glass, it may break or crack if dropped or bumped on hard surface. Handle with care.
- g) Since CMOS LSI is used in this module, take care of static electricity and injure the human earth when handling.
- h) Observe all other precautionary requirements in handling components.
- i) This module has its circuitry PCBs on the rear side and should be carefully handled in order not to be stressed.
- j) The polarizer surface on the panel is treated with Anti-Glare for low reflection. In case of attaching protective board over the LCD. Be careful about the optical interface fringe etc.  
Which degrades display quality.
- k) Connect GND to 4 place of mounting holes to stabilize against EMI and external noise.
- l) There are high voltage portions on the backlight and very dangerous. Careless touch may lead to electrical shock. When exchange lamps or service. Turn off the power without tail.
- m) Be sure not to apply tensile stress to the lamp lead cable.
- n) Cold cathode fluorescent lamp in LCD panel contains a small amount of mercury, please follow local ordinances or regulations for disposal.

## 12. Packing form

Piling number of cartons	5 ( Max )
Packing quantity in one carton	20
Carton size [mm]	494(W)×326(D)×433(H)
Total mass of one carton filled with full modules	15.6kg

### 13 . Reliability test items

No.	Test item	Conditions
1	High temperature & high humidity storage test	Ta= 50 ; 95%RH 240h (No condensation)
2	High temperature storage test	Ta= 70 240h
3	Low temperature storage test	Ta= -35 240h
4	High temperature & high humidity operation test	Ta= 40 ; 95%RH 240h (No condensation)
5	High temperature operation test	Ta= 65 240h
6	Low temperature operation test	Ta= -10 240h
7	Vibration test (non- operating)	Frequency: 10 ~ 57Hz/Vibration width (one side):0.075mm : 58 ~ 500Hz/Gravity:9.8m/s <sup>2</sup> Sweep time : 11 minutes Test period : 3 hours (1 hour for each direction of X,Y,Z)
8	Shock test (non- operating)	Max. gravity : 490m/s <sup>2</sup> Pulse width : 11ms, half sine wave Direction : ± X, ± Y, ± Z once for each direction.

#### 【Result Evaluation Criteria】

Under the display quality test conditions with normal operation state, these shall be no change which may affect practical display function.

### 14 . Others

#### 1) Lot No Label:

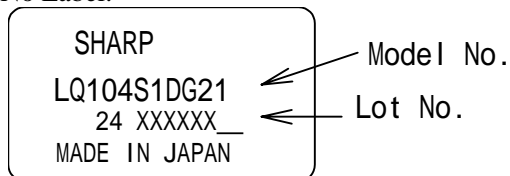

2) Adjusting volume have been set optimally before shipment, so do not change any adjusted value.

If adjusted value is changed, the specification may not be satisfied.

3) Disassembling the module can cause permanent damage and should be strictly avoided.

4) Please be careful since image retention may occur when a fixed pattern is displayed for a long time.

5) Do not use LCD module in the atmosphere of corrosive gases, such as sulfide gas or chlorine gases.

Polarizer may deteriorated or cause chemical reaction that can lead to short circuits at the terminal Points.

Do not use the material, which compounds contain sulfide or chlorine articles in the vicinity of LCD module.

At high temperature, these compounds produce corrosive gases.

6) If any problem occurs in relation to the description of this specification , it shall be resolved through discussion with spirit of cooperation.





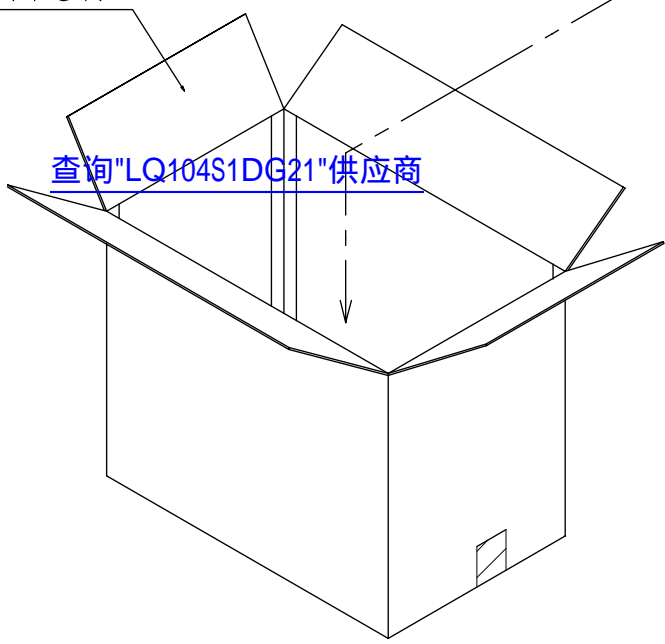

[查询"LQ104S1DG21"供应商](#)

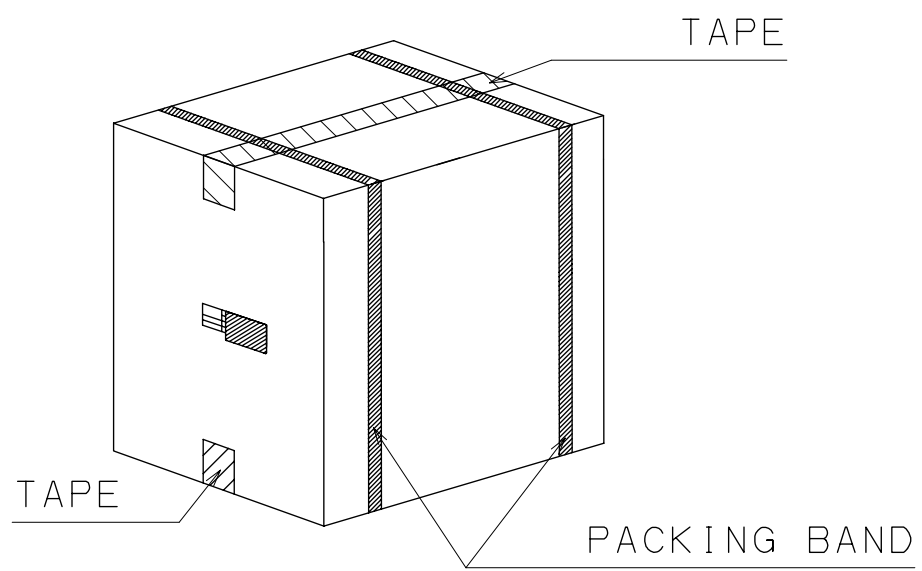
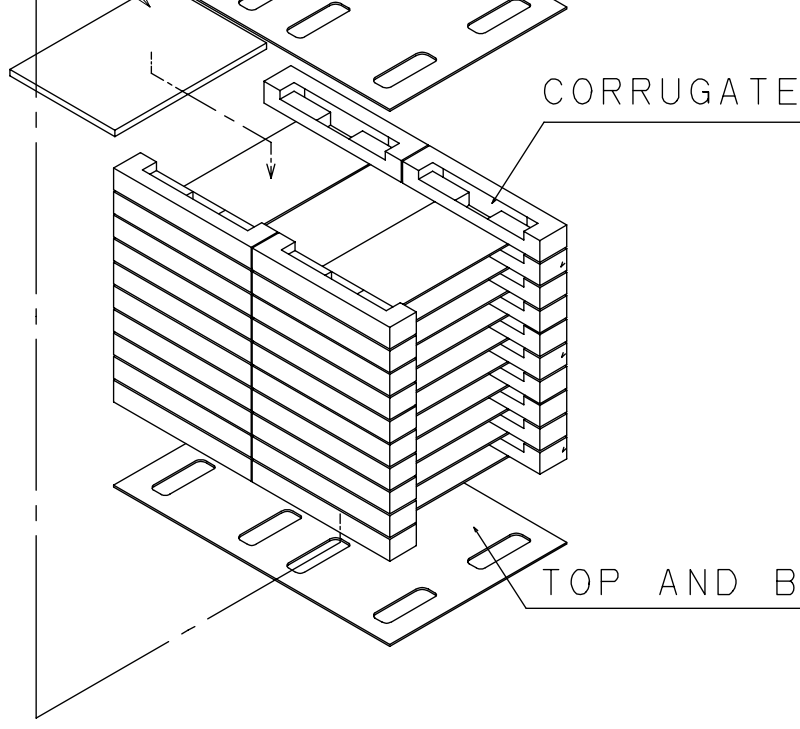

FIG. 3: PACKING FORM

[查询"LQ104S1DG21"供应商](#)

**SPECIFICATIONS ARE SUBJECT TO CHANGE WITHOUT NOTICE.**

Suggested applications (if any) are for standard use; See Important Restrictions for limitations on special applications. See Limited Warranty for SHARP's product warranty. The Limited Warranty is in lieu, and exclusive of, all other warranties, express or implied.

ALL EXPRESS AND IMPLIED WARRANTIES, INCLUDING THE WARRANTIES OF MERCHANTABILITY, FITNESS FOR USE AND FITNESS FOR A PARTICULAR PURPOSE, ARE SPECIFICALLY EXCLUDED. In no event will SHARP be liable, or in any way responsible, for any incidental or consequential economic or property damage.

---

**SHARP**<sup>®</sup>

NORTH AMERICA

EUROPE

JAPAN