

查询"5STP63"供应商

5STD0106

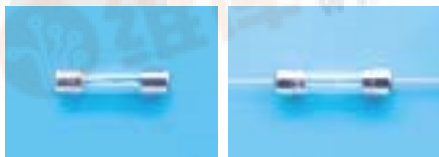

Type 5ST / 5STP

Time-lag Fuse Series (Low Breaking Capacity)

5 x 20mm Glass Tube
RoHS Compliant

Electrical Characteristics (IEC-127-2 STANDARD SHEET 3)

Rated Current	1.5 In		2.1 In		2.75 In		4 In		10 In	
	MIN	MAX	MIN	MAX	MIN	MAX	MIN	MAX	MIN	MAX
63mA to 100mA	1	2	200	10	40	3	10	300		
125mA to 12.5A	1	2	600	10	150	3	20	300		
	hr.	min.	ms	sec	ms	sec	ms	ms		

Approvals

Safety Agency Approvals	Amp range / Volt @ I.R. ability
Certificate No. 0045061 License No. 40000507 Certificate No. EM231	63mA - 6.3A / 250V AC@ 35A or 10 In whichever is greater
Recognized File No. E20624 Acceptance File No. LR39772	
Licence No. 2003010207030316	63mA - 10A / 250V AC@ 35A or 10 In whichever is greater
	63mA - 6.3A / 250V AC@ 35A or 10 In whichever is greater

RoHS Compliant Product

For RoHS Compliant Version, add suffix "R" after catalog number

Operating Temperature

-55°C to +125°C

Physical Specification

Materials

Glass body / Nickel Plated Brass Caps

Lead wire:

Tin plated copper alloy,

Diameter 0.032", 6.3A and less

Diameter 0.040", 8A and above

Marking

On fuse:

"bel", "T", "Current Rating", "L", "250V",

"Appropriate Safety Logos", "✓" (RoHS Version)

On label:

"bel", "5ST" or "5STP", "Current Rating", "Voltage

Rating", "Interrupting Rating", "Appropriate Safety Logos"

and "✓" + suffix "R" for RoHS Version

Packaging

1. In bulk:

5ST - 1,000 pcs per box; 5STP - 500 pcs per box

2. On Axial Tape & Reel:

1,500 pcs per reel

3. Tape & Reel specification:

per EIA-296-E & IEC 286-1

@ 10mm Pitch and 63.5mm inside Tape Spacing

Catalog Number	RoHS Suffix	Ampere Rating	Typical Cold Resistance (ohm)	Volt-drop @100% In (Volt) max.	Melting I ² T < 10 mSec (A ² Sec)	Melting I ² T @10 In (A ² Sec)	Maximum Power Dissipation (W)
5ST (P) 63	-R	63mA	23.9	2.77	0.008	0.021	0.28
5ST (P) 80	-R	80mA	15.7	2.24	0.015	0.036	0.29
5ST (P) 100	-R	100mA	10.3	1.82	0.03	0.06	0.30
5ST (P) 125	-R	125mA	6.8	1.47	0.05	0.11	0.30
5ST (P) 160	-R	160mA	4.4	1.19	0.08	0.19	0.31
5ST (P) 200	-R	200mA	2.9	0.97	0.15	0.33	0.32
5ST (P) 250	-R	250mA	1.9	0.78	0.26	0.58	0.32
5ST (P) 315	-R	315mA	1.3	0.63	0.46	1.01	0.33
5ST (P) 400	-R	400mA	0.82	0.51	0.81	1.76	0.34
5ST (P) 500	-R	500mA	0.54	0.42	1.4	3.1	0.34
5ST (P) 630	-R	630mA	0.22	0.17	0.9	1.5	0.18
5ST (P) 800	-R	800mA	0.15	0.15	1.6	2.5	0.20
5ST (P) 1	-R	1A	0.095	0.13	2.4	3.3	0.17
5ST (P) 1.25	-R	1.25A	0.06	0.09	4.1	5.5	0.19
5ST (P) 1.6	-R	1.6A	0.04	0.09	6.9	8.9	0.23
5ST (P) 2	-R	2A	0.03	0.08	12	15	0.26
5ST (P) 2.5	-R	2.5A	0.02	0.07	20	24	0.31
5ST (P) 3.15	-R	3.15A	0.018	0.07	33	39	0.36
5ST (P) 4	-R	4A	0.014	0.06	56	64	0.42
5ST (P) 5	-R	5A	0.011	0.06	95	105	0.49
5ST (P) 6.3	-R	6.3A	0.008	0.06	160	173	0.57
5ST (P) 8	-R	8A	0.006	0.06	260	282	0.8
5ST (P) 10	-R	10A	0.005	0.06	439	461	1.0
5ST (P) 12.5	-R	12.5A	0.004	0.06	490	679	1.7

Consult manufacturer for other ratings

Mechanical Dimensions

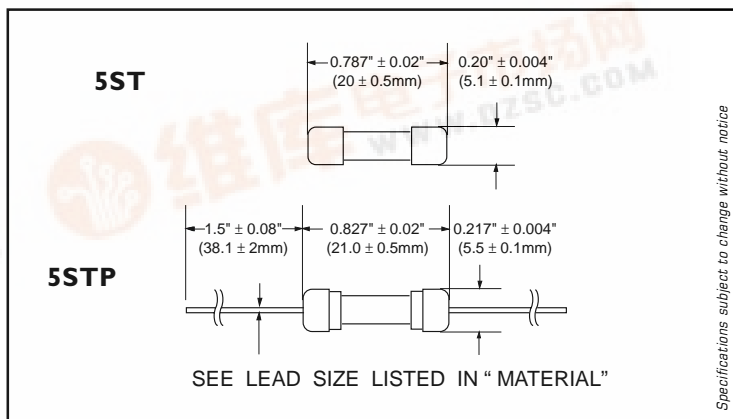

ORDERING INFORMATION SEE LAST 2 PAGES

Specifications subject to change without notice

查询"5STP63"供应商

Type 5ST / 5STP

Time-lag Fuse Series (Low Breaking Capacity)

5 x 20mm Glass Tube
RoHS Compliant

5ST / 5STP - TIME CURRENT CHARACTERISTIC CURVE

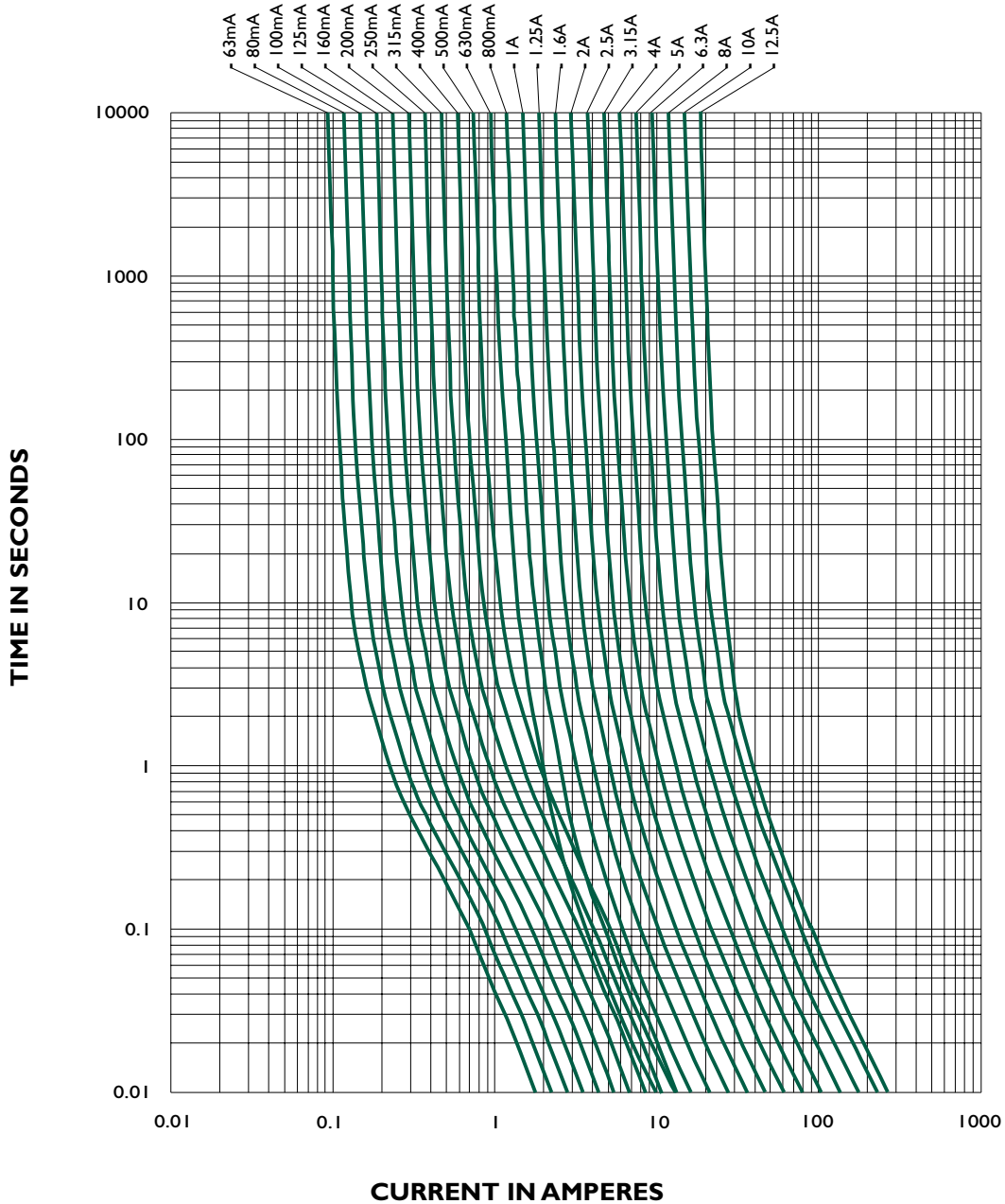

Specifications subject to change without notice

NOTE - see important information under "User Guide" on P.08

Corporate Office

Bel Fuse Inc.
206 Van Vorst Street, Jersey City, NJ 07302
Tel: 201-432-0463
Fax: 201-432-9542
E-Mail: belfuse@belfuse.com
Website: www.belfuse.com

Far East Office

Bel Fuse Ltd.
8F/8 Luk Hop Street
San Po Kong
Kowloon, Hong Kong
Tel: 852-2328-5515
Fax: 852-2352-3706

European Office

Bel Fuse Europe Ltd.
Preston Technology Management Centre
Marsh Lane, Preston PR1 8UD
Lancashire, U.K
Tel: 44-1772-556601
Fax: 44-1772-888366