

Programmable Multi-Chemistry Fast-Charge Management IC

Features

- ▶ Safe management of fast charge for NiCd, NiMH, or Li-Ion battery packs
- ▶ High-frequency switching controller for efficient and simple charger design
- ▶ Pre-charge qualification for detecting shorted, damaged, or overheated cells
- ▶ Fast-charge termination by I_{min} / t_{min} minimum current (Li-Ion), maximum temperature, and maximum charge time
- ▶ Selectable top-off mode for achieving maximum capacity in NiMH batteries
- ▶ Programmable trickle-charge mode for reviving deeply discharged batteries and for post-charge maintenance
- ▶ Built-in battery removal and insertion detection
- ▶ Sleep mode for low power consumption

General Description

The bq2000T is a programmable, monolithic IC for fast-charge management of nickel cadmium (NiCd), nickel metal-hydride (NiMH), or lithium-ion (Li-Ion) batteries in single- or multi-chemistry applications. The bq2000T detects the battery chemistry and proceeds with the optimal charging and termination algorithms. This process eliminates undesirable undercharged or overcharged conditions and allows accurate and safe termination of fast charge.

Depending on the chemistry, the bq2000T provides a number of charge termination criteria:

- Rate of temperature rise, $\Delta T / t$ (for NiCd and NiMH)
- Minimum charging current (for Li-Ion)
- Maximum temperature
- Maximum charge time

For safety, the bq2000T inhibits fast charge until the battery voltage and temperature are within user-defined limits. If the battery voltage is below the low-voltage threshold, the bq2000T uses trickle-charge to condition the battery. For NiMH batteries, the bq2000T provides an optional top-off charge to maximize the battery capacity.

The integrated high-frequency comparator allows the bq2000T to be the basis for a complete, high-efficiency power-conversion circuit for both nickel-based and lithium-based chemistries.

Pin Connections

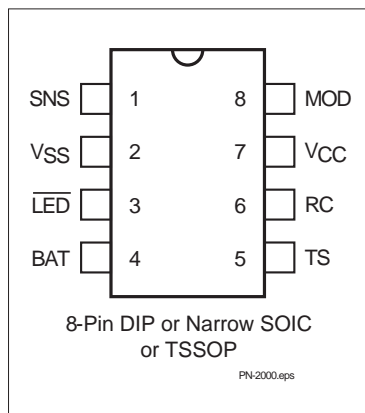

Pin Names

SNS	Current-sense input	TS	Temperature-sense input
V _{SS}	System ground	RC	Timer-program input
$\overline{\text{LED}}$	Charge-status output	V _{CC}	Supply-voltage input
BAT	Battery-voltage input	MOD	Modulation-control output

bq2000T

Pin Descriptions

SNS	Current-sense input
	Enables the bq2000T to sense the battery current via the voltage developed on this pin by an external sense-resistor connected in series with the battery pack
V_{SS}	System Ground
LED	Charge-status output
	Open-drain output that indicates the charging status by turning on, turning off, or flashing an external LED
BAT	Battery-voltage input
	Battery-voltage sense input. A simple resistive divider, across the battery terminals, generates this input.
TS	Temperature-sense input
	Input for an external battery-temperature monitoring circuit. An external resistive divider network with a negative temperature-coefficient thermistor sets the lower and upper temperature thresholds.

RC	Timer-program input
	RC input used to program the maximum charge-time, hold-off period, and trickle rate during the charge cycle, and to disable or enable top-off charge
V_{CC}	Supply-voltage input
MOD	Modulation-control output
	Push-pull output that controls the charging current to the battery. MOD switches high to enable charging current to flow and low to inhibit charging-current flow.

Functional Description

The bq2000T is a versatile, multi-chemistry battery-charge control device. See Figure 1 for a functional block diagram and Figure 2 for the state diagram.

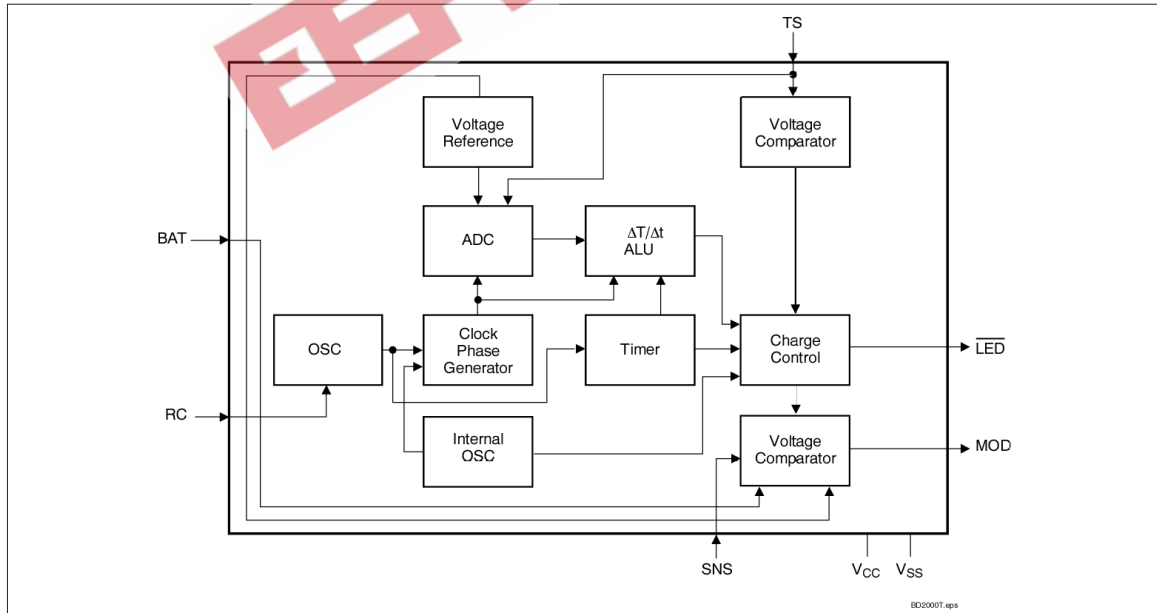

Figure 1. Functional Block Diagram

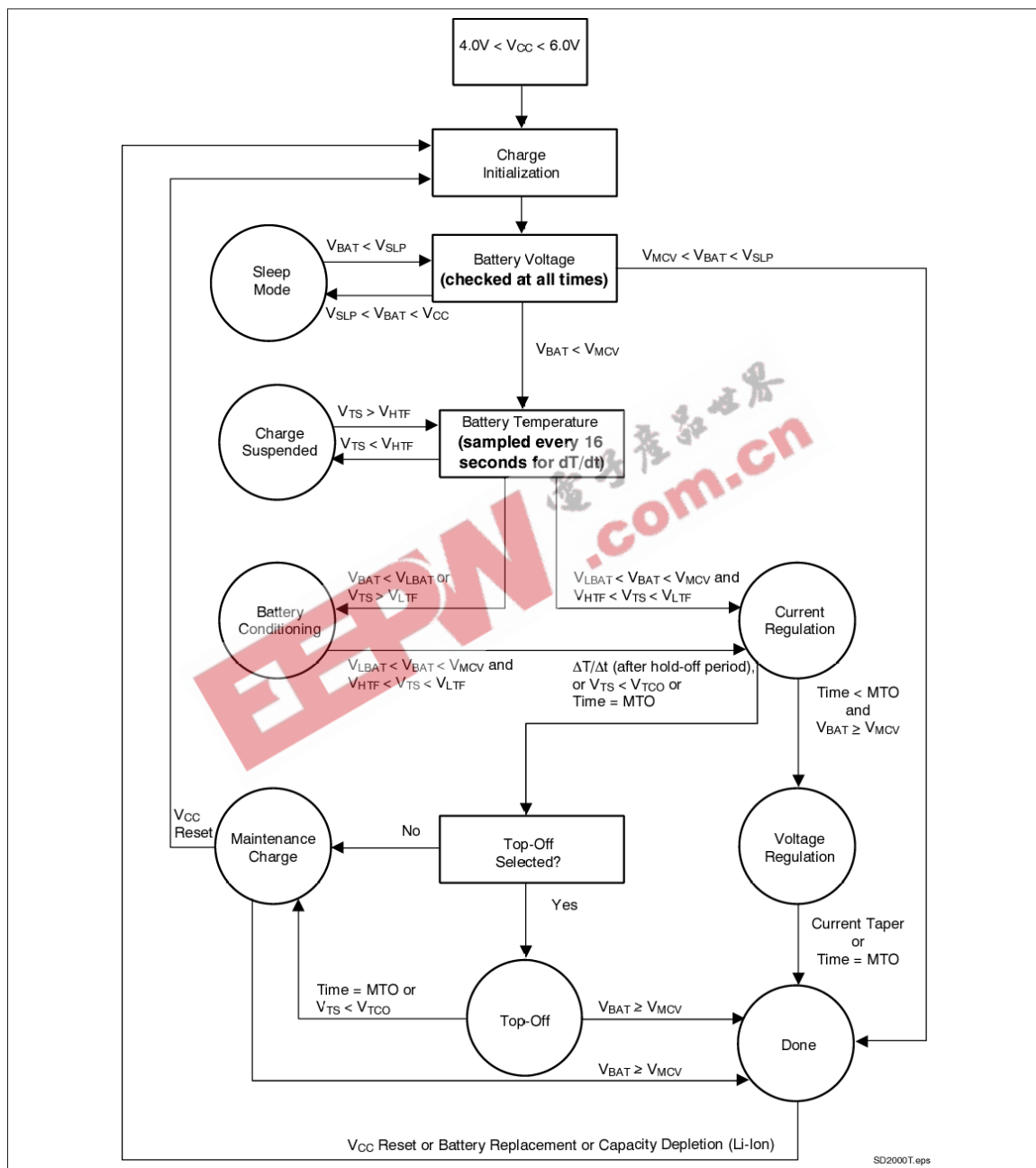

Figure 2. State Diagram

bq2000T

Initiation and Charge Qualification

The bq2000T initiates a charge cycle when it detects

- Application of power to V_{CC}
- Battery replacement
- Exit from sleep mode
- Capacity depletion (Li-Ion only)

Immediately following initiation, the IC enters a charge-qualification mode. The bq2000T charge qualification is based on battery voltage and temperature. If voltage on pin BAT is less than the internal threshold, V_{LBAT} , the bq2000T enters the charge-pending state. This condition indicates the possibility of a defective or shorted battery pack. In an attempt to revive a fully depleted pack, the bq2000T enables the MOD pin to trickle-charge at a rate of once every 1.0s. As explained in the section "Top-Off and Pulse-Trickle Charge," the trickle pulse-width is user-selectable and is set by the value of the resistance connected to pin RC.

During this period, the \overline{LED} pin blinks at a 1Hz rate, indicating the pending status of the charger.

Similarly, the bq2000T suspends fast charge if the battery temperature is outside the V_{LTF} to V_{HTF} range. (See Table 4.) For safety reasons, however, it disables the pulse trickle, in the case of a battery over-temperature condition (i.e., $V_{TS} < V_{HTF}$). Fast

charge begins when the battery temperature and voltage are valid.

Battery Chemistry

The bq2000T detects the battery chemistry by monitoring the battery-voltage profile during fast charge. If the voltage on BAT input rises to the internal V_{MCV} reference, the IC assumes a Li-Ion battery. Otherwise the bq2000T assumes NiCd/NiMH chemistry.

As shown in Figure 6, a resistor voltage-divider between the battery pack's positive terminal and V_{SS} scales the battery voltage measured at pin BAT. In a mixed-chemistry design, a common voltage-divider is used as long as the maximum charge voltage of the nickel-based pack is below that of the Li-Ion pack. Otherwise, different scaling is required.

Once the chemistry is determined, the bq2000T completes the fast charge with the appropriate charge algorithm (Table 1). The user can customize the algorithm by programming the device using an external resistor and a capacitor connected to the RC pin, as discussed in later sections.

NiCd and NiMH Batteries

Following qualification, the bq2000T fast-charges NiCd or NiMH batteries using a current-limited algorithm. During the fast-charge period, it monitors charge time, temperature, and voltage for adherence to the termination criteria. This monitoring is further

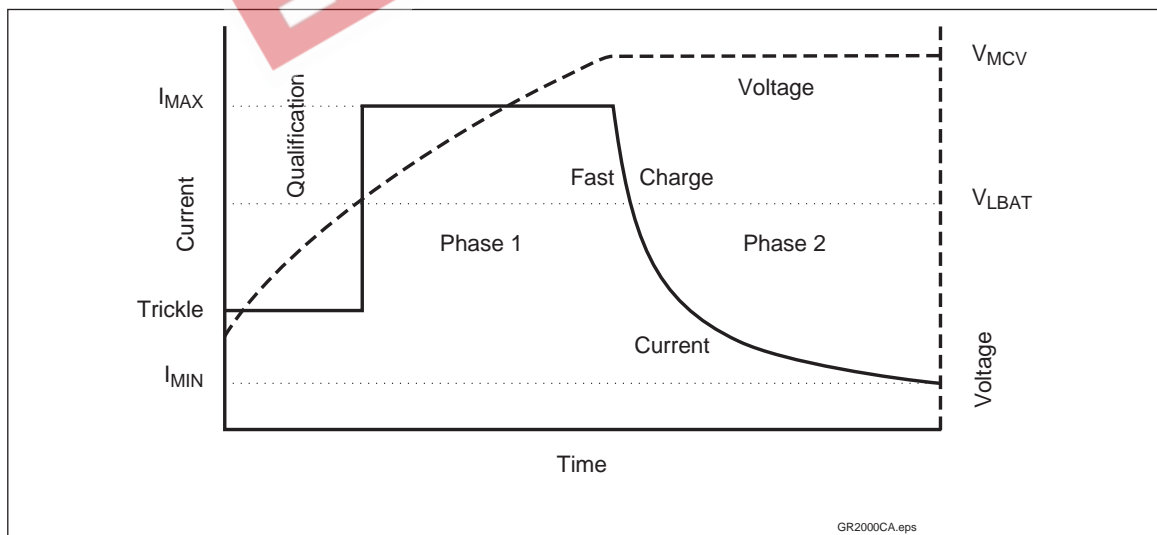

Figure 3. Lithium-Ion Charge Algorithm

Table 1. Charge Algorithm

Battery Chemistry	Charge Algorithm
NiCd or NiMH	<ol style="list-style-type: none"> 1. Charge qualification 2. Trickle charge, if required 3. Fast charge (constant current) 4. Charge termination ($\Delta T/\Delta t$, time) 5. Top-off (optional) 6. Trickle charge
Li-Ion	<ol style="list-style-type: none"> 1. Charge qualification 2. Trickle charge, if required 3. Two-step fast charge (constant current followed by constant voltage) 4. Charge termination (minimum current, time)

explained in later sections. Following fast charge, the battery is topped off, if top-off is selected. The charging cycle ends with a trickle maintenance-charge that continues as long as the voltage on pin BAT remains below V_{MCV} .

Lithium-Ion Batteries

The bq2000T uses a two-phase fast-charge algorithm for Li-Ion batteries (Figure 3). In phase one, the bq2000T regulates constant current until V_{BAT} rises to V_{MCV} . The bq2000T then moves to phase two, regulates the battery with constant voltage of V_{MCV} , and terminates when the charging current falls below the I_{MIN} threshold. A new charge cycle is started if the cell voltage falls below the V_{RCH} threshold.

During the current-regulation phase, the bq2000T monitors charge time, battery temperature, and battery voltage for adherence to the termination criteria. During the final constant-voltage stage, in addition to the charge time and temperature, it monitors the charge current as a termination criterion. There is no post-charge maintenance mode for Li-Ion batteries.

Charge Termination

Maximum Charge Time (NiCd, NiMH, and Li-Ion)

The bq2000T sets the maximum charge-time through pin RC. With the proper selection of external resistor and capacitor, various time-out values may be achieved. Figure 4 shows a typical connection.

The following equation shows the relationship between the R_{MTO} and C_{MTO} values and the maximum charge time (MTO) for the bq2000T:

$$MTO = R_{MTO} * C_{MTO} * 35,988$$

MTO is measured in minutes, R_{MTO} in ohms, and C_{MTO} in farads. (Note: R_{MTO} and C_{MTO} values also de-

termine other features of the device. See Tables 2 and 3 for details.)

For Li-Ion cells, the bq2000T resets the MTO when the battery reaches the constant-voltage phase of the charge. This feature provides the additional charge time required for Li-Ion cells.

Maximum Temperature (NiCd, NiMH, Li-Ion)

A negative-coefficient thermistor, referenced to V_{SS} and placed in thermal contact with the battery, may be used as a temperature-sensing device. Figure 5 shows a typical temperature-sensing circuit.

During fast charge, the bq2000T compares the battery temperature to an internal high-temperature cutoff threshold, V_{TCO} . As shown in Table 4, high-temperature termination occurs when voltage at pin TS is less than this threshold.

T/ t (NiCd, NiMH)

When fast charging, the bq2000T monitors the voltage at pin TS for rate of temperature change detection, $\Delta T/\Delta t$. The bq2000T samples the voltage at the TS pin every 16s and compares it to the value measured 2 samples earlier. This feature terminates fast charge if this voltage declines at a rate of

$$\frac{V_{CC} \left(\frac{V}{Min} \right)}{161}$$

Figure 5 shows a typical connection diagram.

Minimum Current (Li-Ion Only)

The bq2000T monitors the charging current during the voltage-regulation phase of Li-Ion batteries. Fast charge is terminated when the current is tapered off to 7% of the maximum charging current. **Please note that this threshold is different for the bq2000.**

Initial Hold-Off Period

bq2000T

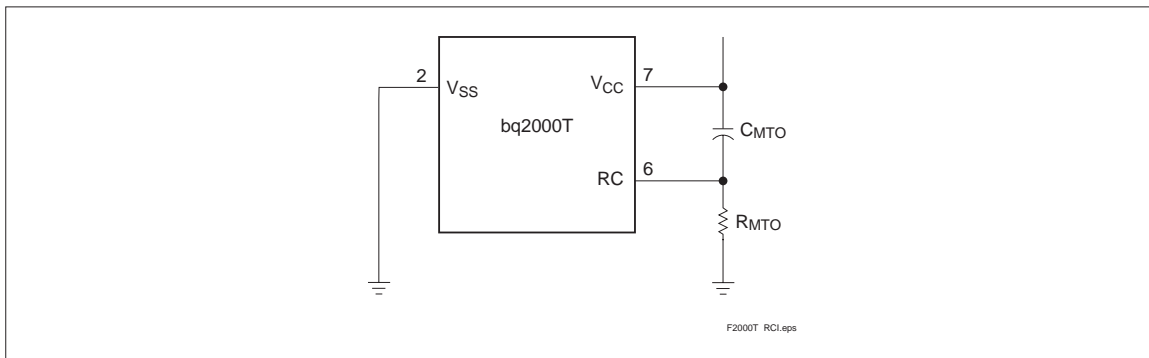

Figure 4. Typical Connection for the RC Input

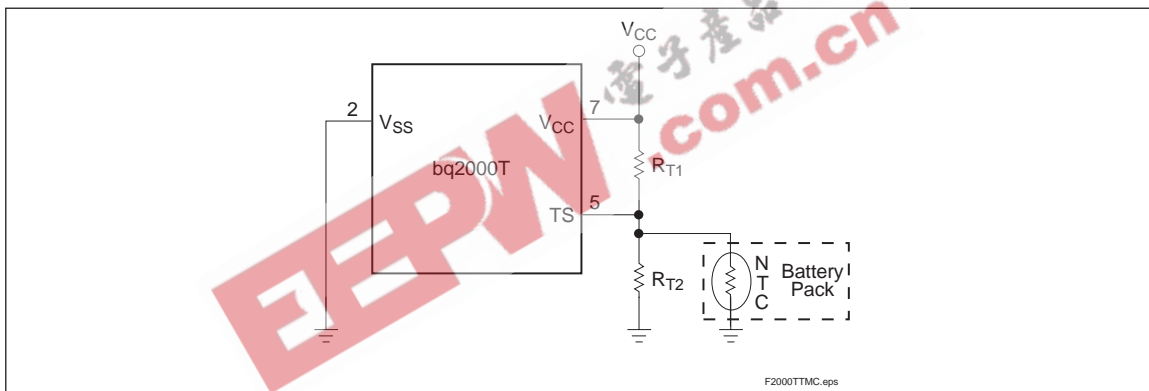

Figure 5. Temperature Monitoring Configuration

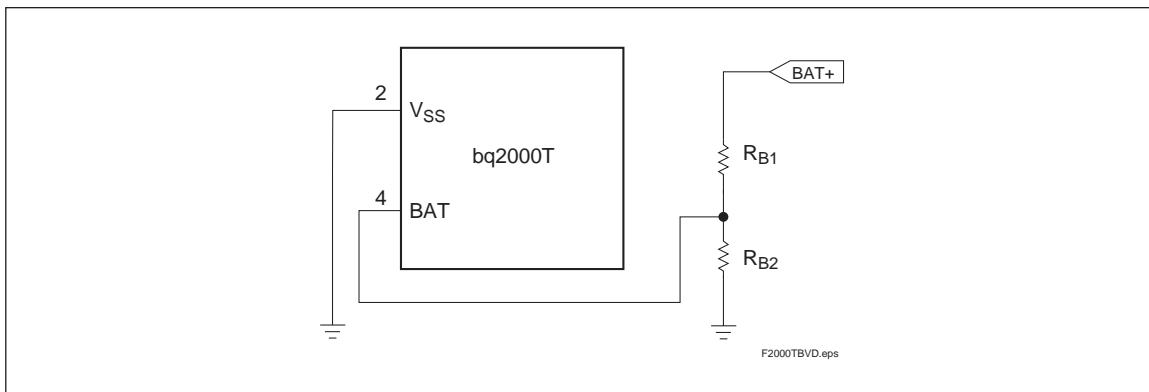

Figure 6. Battery Voltage Divider

The values of the external resistor and capacitor connected to pin RC set the initial hold-off period. During this period, the bq2000T avoids early termination by disabling the $\Delta T/\Delta t$ feature. This period is fixed at the programmed value of the maximum charge time divided by 32.

$$\text{hold-off period} = \frac{\text{maximum time} - \text{out}}{32}$$

Top-Off and Pulse-Trickle Charge

An optional top-off charge is available for NiCd or NiMH batteries. Top-off may be desirable on batteries that have a tendency to terminate charge before reaching full capacity. To enable this option, the capacitance value of C_{MTO} connected to pin RC (Figure 4) should be greater than $0.13\mu\text{F}$, and the value of the resistor connected to this pin should be less than $15\text{k}\Omega$. To disable top-off, the capacitance value should be less than $0.07\mu\text{F}$. The tolerance of the capacitor needs to be taken into account in component selection.

Once enabled, the top-off is performed over a period equal to the maximum charge time at a rate of $1/16$ that of fast charge.

Following top-off, the bq2000T trickle-charges the battery by enabling the MOD to charge at a rate of once every 1.0 second. The trickle pulse-width is user-selectable and is set by the value of the resistor R_{MTO} , which is on pin RC. Figure 7 shows the relationship between the trickle pulse-width and the value of R_{MTO} . The typical tolerance of the pulsewidth below $150\text{k}\Omega$ is $\pm 10\%$.

During top-off and trickle-charge, the bq2000T monitors battery voltage and temperature. These functions are suspended if the battery voltage rises above the maximum cell voltage (V_{MCV}) or if the temperature exceeds the high-temperature fault threshold (V_{HTF}).

Charge Current Control

The bq2000T controls the charge current through the MOD output pin. The current-control circuit supports a switching-current regulator with frequencies up to 500kHz . The bq2000T monitors charge current at the SNS input by the voltage drop across a sense-resistor, R_{SNS} , in series with the battery pack. See Figure 9 for a typical current-sensing circuit. R_{SNS} is sized to provide the desired fast-charge current (I_{MAX}):

$$I_{MAX} = \frac{0.05}{R_{SNS}}$$

If the voltage at the SNS pin is greater than V_{SNSLO} or less than V_{SNSHI} , the bq2000T switches the MOD output high to pass charge current to the battery. When the SNS voltage is less than V_{SNSLO} or greater than V_{SNSHI} , the bq2000T switches the MOD output low to shut off charging current to the battery. Figure 8 shows a typical multi-chemistry charge circuit.

Voltage Input

As shown in Figure 6, a resistor voltage-divider between the battery pack's positive terminal and V_{SS} scales the battery voltage measured at pin BAT.

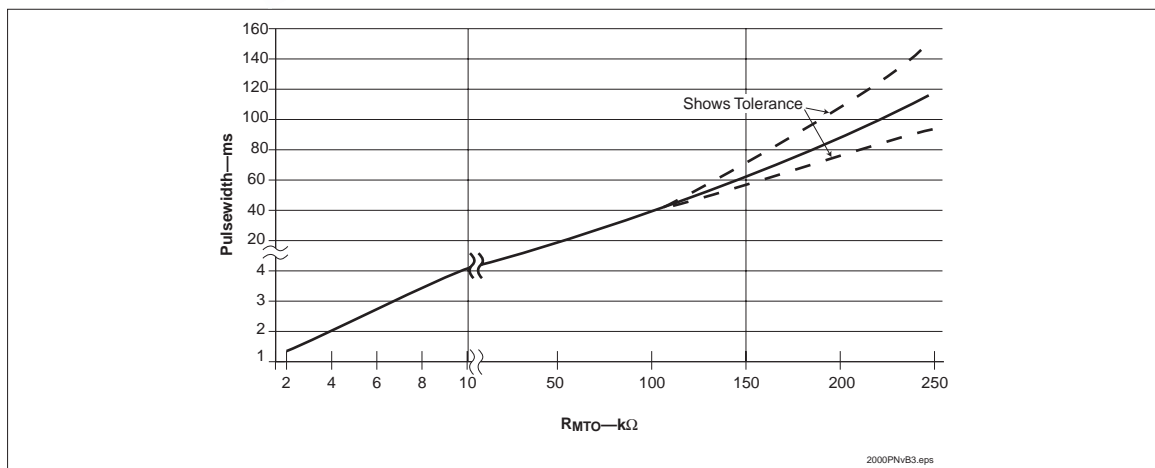

Figure 7. Relationship Between Trickle Pulse-Width and Value of R_{MTO}

bq2000T

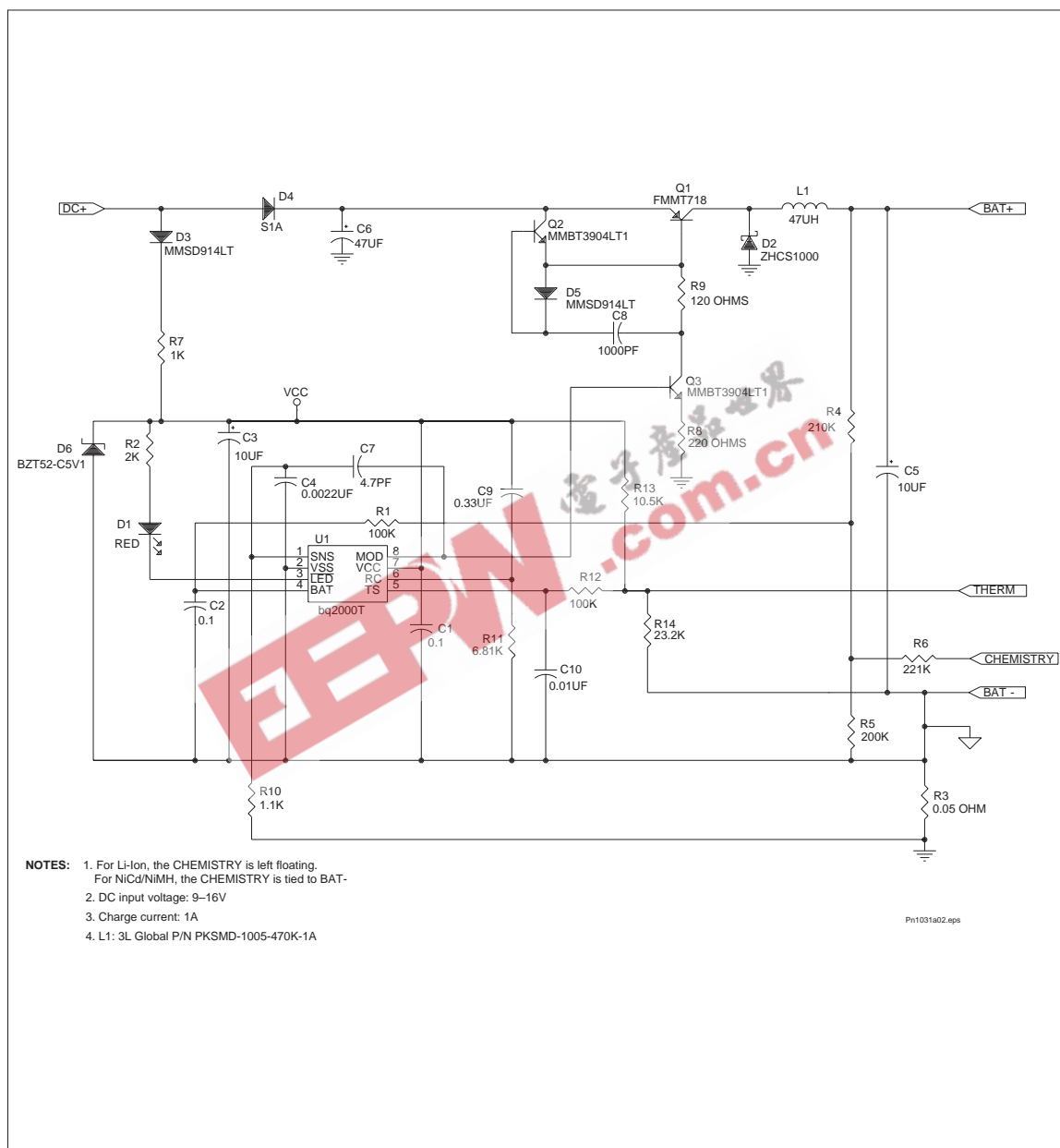

Figure 8. Single-Cell Li-Ion, Three-Cell NiCd/NiMH 1A Charger

Table 2. Summary of NiCd or NiMH Charging Characteristics

Parameter	Value
Maximum cell voltage (V_{MCV})	2V
Minimum pre-charge qualification voltage (V_{LBAT})	950mV
High-temperature cutoff voltage (V_{TCO})	$0.225 * V_{CC}$
High-temperature fault voltage (V_{HTF})	$0.25 * V_{CC}$
Low-temperature fault voltage (V_{LTF})	$0.5 * V_{CC}$
bq2000T fast-charge maximum time out (MTO)	$R_{MTO} * C_{MTO} * 35,988$
Fast-charge charging current (I_{MAX})	$0.05/R_{SNS}$
Hold-off period	MTO/32
Top-off charging current (optional)	$I_{MAX}/16$
Top-off period (optional)	MTO
Trickle-charge frequency	1Hz
Trickle-charge pulse-width	See Figure 7

For Li-Ion battery packs, the resistor values R_{B1} and R_{B2} are calculated by the following equation:

$$\frac{R_{B1}}{R_{B2}} = \left(N * \frac{V_{CELL}}{V_{MCV}} \right) - 1$$

where N is the number of cells in series and V_{CELL} is the manufacturer-specified charging voltage. The end-to-end input impedance of this resistive divider network should be at least 200k Ω and no more than 1M Ω .

A NiCd or NiMH battery pack consisting of N series-cells may benefit by the selection of the R_{B1} value to be N-1 times larger than the R_{B2} value.

In a mixed-chemistry design, a common voltage-divider is used as long as the maximum charge voltage of the nickel-based pack is below that of the Li-Ion pack. Otherwise, different scaling is required.

Temperature Monitoring

The bq2000T measures the temperature by the voltage at the TS pin. This voltage is typically generated by a negative-temperature-coefficient thermistor. The bq2000T compares this voltage against its internal threshold voltages to determine if charging is safe.

Table 3. Summary of Li-Ion Charging Characteristics

Parameter	Value
Maximum cell voltage (V_{MCV})	2V
Minimum pre-charge qualification voltage (V_{LBAT})	950mV
High-temperature cutoff voltage (V_{TCO})	$0.225 * V_{CC}$
High-temperature fault voltage (V_{HTF})	$0.25 * V_{CC}$
Low-temperature fault voltage (V_{LTF})	$0.5 * V_{CC}$
bq2000T fast-charge maximum time-out (MTO)	$2 * R_{MTO} * C_{MTO} * 35,988$
Fast-charge charging current (I_{MAX})	$0.05/R_{SNS}$
Hold-off period	MTO/32
Minimum current (for fast-charge termination)	$I_{MAX}/14$
Trickle-charge frequency (before fast charge only)	1Hz
Trickle-charge pulse-width (before fast charge only)	See Figure 7

bq2000T

Table 4. Temperature-Monitoring Conditions

Temperature	Condition	Action
$V_{TS} > V_{LTF}$	Cold battery—checked at all times	Suspends fast charge or top-off and timer Allows trickle charge—LED flashes at 1Hz rate during pre-charge qualification and fast charge
$V_{HTF} < V_{TS} < V_{LTF}$	Optimal operating range	Allows charging
$V_{TS} < V_{HTF}$	Hot battery—checked during charge qualification and top-off and trickle-charge	Suspends fast-charge initiation, does not allow trickle charge—LED flashes at 1Hz rate during pre-charge qualification

These thresholds are the following:

- High-temperature cutoff voltage: $V_{TCO} = 0.225 * V_{CC}$
This voltage corresponds to the maximum temperature (TCO) at which fast charging is allowed. The bq2000T terminates fast charge if the voltage on pin TS falls below V_{TCO} .
- High-temperature fault voltage: $V_{HTF} = 0.25 * V_{CC}$
This voltage corresponds to the temperature (HTF) at which fast charging is allowed to begin.
- Low-temperature fault voltage: $V_{LTF} = 0.5 * V_{CC}$
This voltage corresponds to the minimum temperature (LTF) at which fast charging or top-off is allowed. If the voltage on pin TS rises above V_{LTF} , the bq2000T suspends fast charge or

Table 4 summarizes these various conditions.

Charge Status Display

The charge status is indicated by open-drain output LED. Table 5 summarizes the display output of the bq2000T.

Table 5. Charge Status Display

Charge Action State	LED Status
Battery absent	High impedance
Pre-charge qualification	1Hz flash
Trickle charge (before fast charge)	1Hz flash
Fast charging	Low
Top-off or trickle (after fast charge, NiCd, NiMH only)	High impedance
Charge complete	High impedance

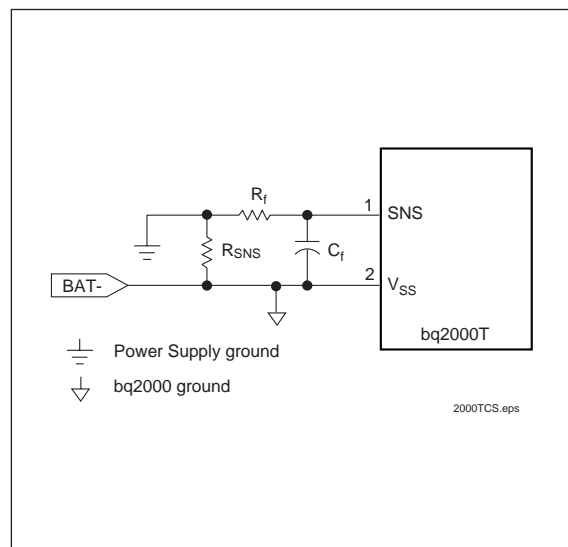

Figure 9. Current-Sensing Circuit

top-off but does not terminate charge. When the voltage falls back below V_{LTF} , fast charge or top-off resumes from the point where suspended. Trickle-charge is allowed during this condition.

Sleep Mode

The bq2000T features a sleep mode for low power consumption. This mode is enabled when the voltage at pin BAT is above the low-power-mode threshold, V_{SLP} . During sleep mode, the bq2000T shuts down all internal circuits, drives the LED output to high-impedance state, and drives pin MOD to low. Restoring BAT below the V_{MCV} threshold initiates the IC and starts a fast-charge cycle.

EEPW 电子產品世界
.com.cn

Absolute Maximum Ratings

Symbol	Parameter	Minimum	Maximum	Unit	Notes
V _{CC}	V _{CC} relative to V _{SS}	-0.3	+7.0	V	
V _T	DC voltage applied on any pin, excluding V _{CC} relative to V _{SS}	-0.3	+7.0	V	
T _{OPR}	Operating ambient temperature	-20	+70	°C	
T _{STG}	Storage temperature	-40	+125	°C	
T _{SOLDER}	Soldering temperature	-	+260	°C	10s max.

Note: Permanent device damage may occur if Absolute Maximum Ratings are exceeded. Functional operation should be limited to the Recommended DC Operating Conditions detailed in this data sheet. Exposure to conditions beyond the operational limits for extended periods of time may affect device reliability.

DC Thresholds (T_A = T_{OPR}; V_{CC} = 5V ±20% unless otherwise specified)

Symbol	Parameter	Rating	Tolerance	Unit	Notes
V _{TCO}	Temperature cutoff	0.225 * V _{CC}	±5%	V	Voltage at pin TS
V _{HTF}	High-temperature fault	0.25 * V _{CC}	±5%	V	Voltage at pin TS
V _{LTF}	Low-temperature fault	0.5 * V _{CC}	±5%	V	Voltage at pin TS
V _{MCV}	Maximum cell voltage	2.00	±0.75%	V	V _{BAT} > V _{MCV} inhibits fast charge
V _{LBAT}	Minimum cell voltage	950	±5%	mV	Voltage at pin BAT
V _{THERM}	TS input change for ΔT/Δt detection	$-\frac{V_{CC}}{161}$	±25%	V/Min	
V _{SNSHI}	High threshold at SNS, resulting in MOD-low	50	±10	mV	Voltage at pin SNS
V _{SNSLO}	Low threshold at SNS, resulting in MOD-high	-50	±10	mV	Voltage at pin SNS
V _{SLP}	Sleep-mode input threshold	V _{CC} - 1	±0.5	V	Applied to pin BAT
V _{RCH}	Recharge threshold	V _{MCV} - 0.1	±0.02	V	At pin BAT

bq2000T

Recommended DC Operating Conditions ($T_A = T_{OPR}$)

Symbol	Condition	Minimum	Typical	Maximum	Unit	Notes
V_{CC}	Supply voltage	4.0	5.0	6.0	V	
I_{CC}	Supply current	-	0.5	1	mA	Exclusive of external loads
I_{CCS}	Sleep current	-	-	5	μ A	$V_{BAT} = V_{SLP}$
V_{TS}	Thermistor input	0.5	-	V_{CC}	V	$V_{TS} < 0.5V$ prohibited
V_{OH}	Output high	$V_{CC} - 0.2$	-	-	V	MOD, $I_{OH} = 20mA$
V_{OL}	Output low	-	-	0.2	V	MOD, LED, $I_{OL} = 20mA$
I_{OZ}	High-impedance leakage current	-	-	5	μ A	LED
I_{snk}	Sink current	-	-	20	mA	MOD, LED
R_{MTO}	Charge timer resistor	2	-	250	k Ω	
C_{MTO}	Charge timer capacitor	0.001	-	1.0	μ F	

Note: All voltages relative to V_{SS} except as noted.

Impedance

Symbol	Parameter	Minimum	Typical	Maximum	Unit
R_{BAT}	Battery input impedance	10	-	-	M Ω
R_{TS}	TS input impedance	10	-	-	M Ω
R_{SNS}	SNS input impedance	10	-	-	M Ω

Timing ($T_A = T_{OPR}$; $V_{CC} = 5V \pm 20\%$ unless otherwise specified)

Symbol	Parameter	Minimum	Typical	Maximum	Unit
d_{MTO}	MTO time-base variation	-5	-	+5	%
f_{TRKL}	Pulse-trickle frequency	0.9	1.0	1.1	Hz

Data Sheet Revision History

Change No.	Page No.	Description	Nature of Change
1	5	Minimum current termination	Was: 14% Is: 7%
1	3	Added state diagram	
1	7	Changed capacitor value for enabling top-off	Was: 0.13 μ F Is: 0.26 μ F
1	8	Figure 8	Schematic updated
1	10	V_{TCO} , V_{HTF} , V_{LTF}	Tolerance updated
2	9	Minimum current (for fast charge termination)	Was: $I_{MAX}/7$ Is: $I_{MAX}/14$
3	2	Change Figure 1	Connection added between TS and ADC and connection deleted between BAT and ADC.
3	2	Change Figure 2	Battery temperature was: (checked at all times) Is: (sampled every 16 seconds for $\Delta T/\Delta t$)
33	14	Change package	Was: 8-Pin TSSOP ~ TS Package Suffix Is: 8-Pin PSOP
13	13	Change Ordering Information	Was: TS = 8-pin TSSOP Is: PW = 8-pin TSSOP

Note: Change 1 = May 1999 B changes to Final from Jan. 1999 Preliminary data sheet.
Change 2 = February 2000 changes from May 1999 B.
Change 3 = February 2001 C changes from February 2000

Ordering Information

bq2000T

Package Option:

PN = 8-pin narrow plastic DIP
SN = 8-pin narrow SOIC
PW = 8-pin SSOP

Device:

bq2000T Multi-Chemistry Fast-Charge IC with $\Delta T/\Delta t$ Detection

8-Pin DIP (PN)

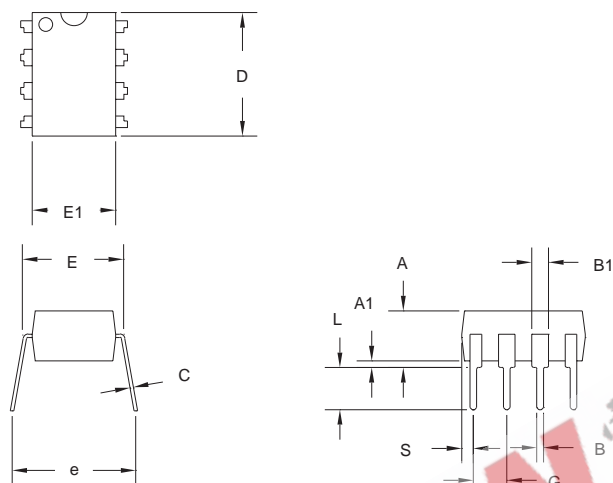

8-Pin PN (0.300" DIP)

Dimension	Inches		Millimeters	
	Min.	Max.	Min.	Max.
A	0.160	0.180	4.06	4.57
A1	0.015	0.040	0.38	1.02
B	0.015	0.022	0.38	0.56
B1	0.055	0.065	1.40	1.65
C	0.008	0.013	0.20	0.33
D	0.350	0.380	8.89	9.65
E	0.300	0.325	7.62	8.26
E1	0.230	0.280	5.84	7.11
e	0.300	0.370	7.62	9.40
G	0.090	0.110	2.29	2.79
L	0.115	0.150	2.92	3.81
S	0.020	0.040	0.51	1.02

8-Pin SOIC Narrow (SN)

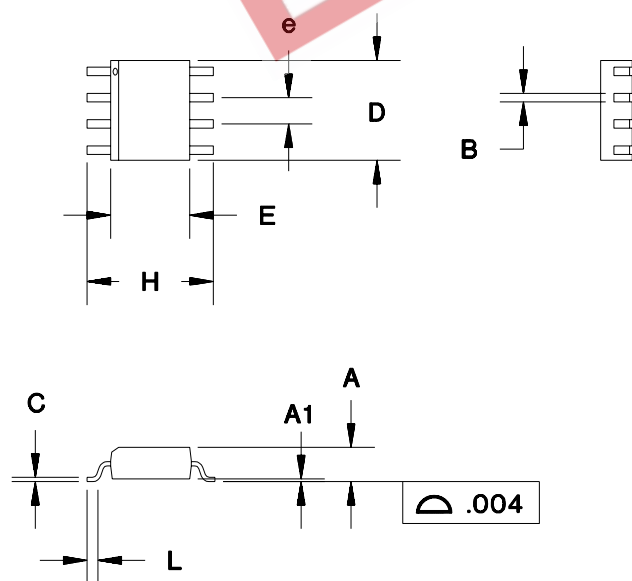

8-Pin SN (0.150" SOIC)

Dimension	Inches		Millimeters	
	Min.	Max.	Min.	Max.
A	0.060	0.070	1.52	1.78
A1	0.004	0.010	0.10	0.25
B	0.013	0.020	0.33	0.51
C	0.007	0.010	0.18	0.25
D	0.185	0.200	4.70	5.08
E	0.150	0.160	3.81	4.06
e	0.045	0.055	1.14	1.40
H	0.225	0.245	5.72	6.22
L	0.015	0.035	0.38	0.89

bq2000T

8-Pin PSOP
14 PINS SHOWN

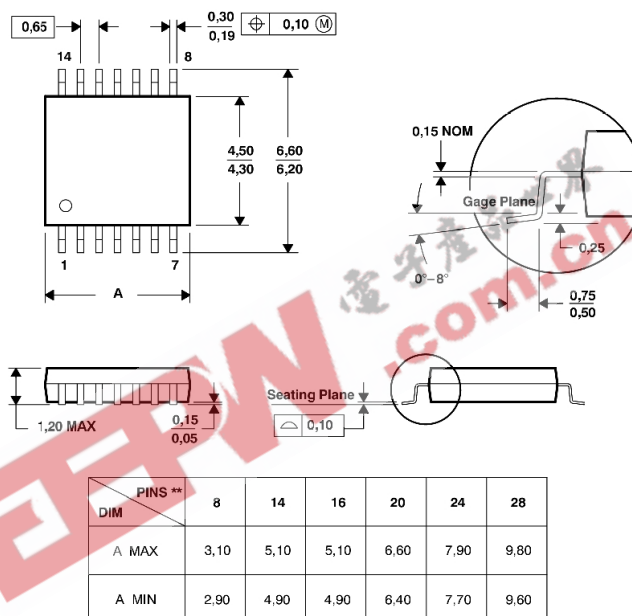

4040064/F 01/97

- NOTES: A. All linear dimensions are in millimeters.
 B. This drawing is subject to change without notice.
 C. Body dimensions do not include mold flash or protrusion not to exceed 0,15.
 D. Falls within JEDEC MO-153

PACKAGING INFORMATION

Orderable Device	Status ⁽¹⁾	Package Type	Package Drawing	Pins	Package Qty	Eco Plan ⁽²⁾	Lead/Ball Finish	MSL Peak Temp ⁽³⁾
BQ2000TPN-B5	ACTIVE	PDIP	P	8	50	Pb-Free (RoHS)	CU SNPB	Level-NC-NC-NC
BQ2000TPW	ACTIVE	TSSOP	PW	8	150	None	CU NIPDAU	Level-1-220C-UNLIM
BQ2000TPWR	ACTIVE	TSSOP	PW	8	2000	None	CU NIPDAU	Level-1-220C-UNLIM
BQ2000TSN-B5	ACTIVE	SOIC	D	8	75	None	CU SNPB	Level-1-220C-UNLIM
BQ2000TSN-B5TR	ACTIVE	SOIC	D	8	2500	None	CU SNPB	Level-1-220C-UNLIM

⁽¹⁾ The marketing status values are defined as follows:

ACTIVE: Product device recommended for new designs.

LIFEBUY: TI has announced that the device will be discontinued, and a lifetime-buy period is in effect.

NRND: Not recommended for new designs. Device is in production to support existing customers, but TI does not recommend using this part in a new design.

PREVIEW: Device has been announced but is not in production. Samples may or may not be available.

OBSOLETE: TI has discontinued the production of the device.

⁽²⁾ Eco Plan - May not be currently available - please check <http://www.ti.com/productcontent> for the latest availability information and additional product content details.

None: Not yet available Lead (Pb-Free).

Pb-Free (RoHS): TI's terms "Lead-Free" or "Pb-Free" mean semiconductor products that are compatible with the current RoHS requirements for all 6 substances, including the requirement that lead not exceed 0.1% by weight in homogeneous materials. Where designed to be soldered at high temperatures, TI Pb-Free products are suitable for use in specified lead-free processes.

Green (RoHS & no Sb/Br): TI defines "Green" to mean "Pb-Free" and in addition, uses package materials that do not contain halogens, including bromine (Br) or antimony (Sb) above 0.1% of total product weight.

⁽³⁾ MSL, Peak Temp. -- The Moisture Sensitivity Level rating according to the JEDEC industry standard classifications, and peak solder temperature.

Important Information and Disclaimer: The information provided on this page represents TI's knowledge and belief as of the date that it is provided. TI bases its knowledge and belief on information provided by third parties, and makes no representation or warranty as to the accuracy of such information. Efforts are underway to better integrate information from third parties. TI has taken and continues to take reasonable steps to provide representative and accurate information but may not have conducted destructive testing or chemical analysis on incoming materials and chemicals. TI and TI suppliers consider certain information to be proprietary, and thus CAS numbers and other limited information may not be available for release.

In no event shall TI's liability arising out of such information exceed the total purchase price of the TI part(s) at issue in this document sold by TI to Customer on an annual basis.

IMPORTANT NOTICE

Texas Instruments Incorporated and its subsidiaries (TI) reserve the right to make corrections, modifications, enhancements, improvements, and other changes to its products and services at any time and to discontinue any product or service without notice. Customers should obtain the latest relevant information before placing orders and should verify that such information is current and complete. All products are sold subject to TI's terms and conditions of sale supplied at the time of order acknowledgment.

TI warrants performance of its hardware products to the specifications applicable at the time of sale in accordance with TI's standard warranty. Testing and other quality control techniques are used to the extent TI deems necessary to support this warranty. Except where mandated by government requirements, testing of all parameters of each product is not necessarily performed.

TI assumes no liability for applications assistance or customer product design. Customers are responsible for their products and applications using TI components. To minimize the risks associated with customer products and applications, customers should provide adequate design and operating safeguards.

TI does not warrant or represent that any license, either express or implied, is granted under any TI patent right, copyright, mask work right, or other TI intellectual property right relating to any combination, machine, or process in which TI products or services are used. Information published by TI regarding third-party products or services does not constitute a license from TI to use such products or services or a warranty or endorsement thereof. Use of such information may require a license from a third party under the patents or other intellectual property of the third party, or a license from TI under the patents or other intellectual property of TI.

Reproduction of information in TI data books or data sheets is permissible only if reproduction is without alteration and is accompanied by all associated warranties, conditions, limitations, and notices. Reproduction of this information with alteration is an unfair and deceptive business practice. TI is not responsible or liable for such altered documentation.

Resale of TI products or services with statements different from or beyond the parameters stated by TI for that product or service voids all express and any implied warranties for the associated TI product or service and is an unfair and deceptive business practice. TI is not responsible or liable for any such statements.

Following are URLs where you can obtain information on other Texas Instruments products and application solutions:

Products		Applications	
Amplifiers	amplifier.ti.com	Audio	www.ti.com/audio
Data Converters	dataconverter.ti.com	Automotive	www.ti.com/automotive
DSP	dsp.ti.com	Broadband	www.ti.com/broadband
Interface	interface.ti.com	Digital Control	www.ti.com/digitalcontrol
Logic	logic.ti.com	Military	www.ti.com/military
Power Mgmt	power.ti.com	Optical Networking	www.ti.com/opticalnetwork
Microcontrollers	microcontroller.ti.com	Security	www.ti.com/security
		Telephony	www.ti.com/telephony
		Video & Imaging	www.ti.com/video
		Wireless	www.ti.com/wireless

Mailing Address: Texas Instruments
Post Office Box 655303 Dallas, Texas 75265