

CMOS 4-BIT MAGNITUDE COMPARATOR

FEATURES

- ◆ Binary or BCD Comparison
- ◆ Expandable
- ◆ A<B, A=B, A>B Outputs Available

DESCRIPTION

This 4-Bit Magnitude Comparator performs comparison of straight binary and straight BCD (8-4-2-1) codes. Three decisions about two 4-bit words (A, B) are made and are externally available at three outputs. These devices are fully expandable to any number of bits without external gates. Words of greater length may be compared by connecting comparators in cascade. The A<B and A=B outputs of a stage handling less-significant bits are connected to the corresponding A<B and A=B inputs of the next stage handling more-significant bits. The A>B cascading input is connected to a high level. The stage handling the least-significant bits must have a high-level voltage applied to the A=B and A>B inputs. An alternate method of cascading which reduces the comparison time is shown under Applications Information.

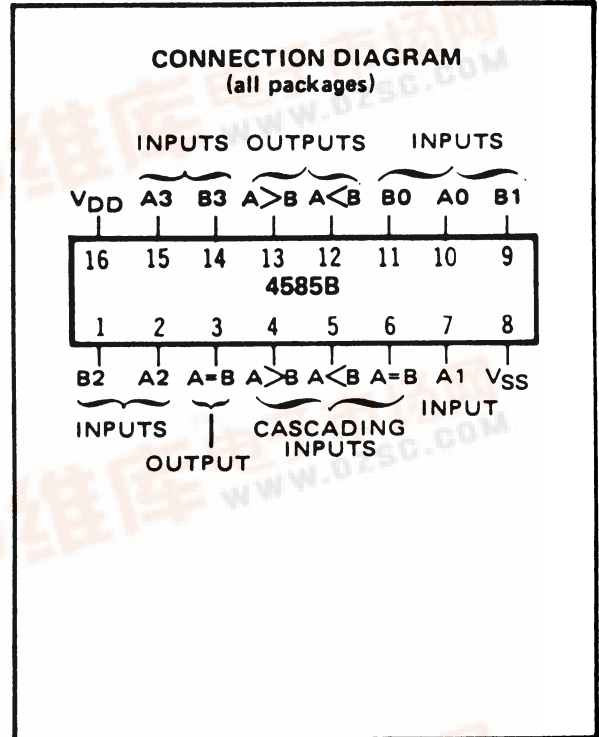

RECOMMENDED OPERATING CONDITIONS

For maximum reliability:

DC Supply Voltage	$V_{DD} - V_{SS}$	3 to 15	Vdc
Operating Temperature	T_A		
C		-55 to +125	°C
E		-40 to +85	°C

TRUTH TABLE

Inputs				Cascading			Outputs		
Comparing									
A3, B3	A2, B2	A1, B1	A0, B0	A<B	A=B	A>B	A<B	A=B	A>B
A3>B3	X	X	X	X	X	1	0	0	1
A3=B3	A2>B2	X	X	X	X	1	0	0	1
A3=B3	A2=B2	A1>B1	X	X	X	1	0	0	1
A3=B3	A2=B2	A1=B1	A0>B0	X	X	1	0	0	1
A3=B3	A2=B2	A1=B1	A0=B0	0	0	1	0	0	1
A3=B3	A2=B2	A1=B1	A0=B0	0	1	X	0	1	0
A3=B3	A2=B2	A1=B1	A0=B0	1	0	X	1	0	0
A3=B3	A2=B2	A1=B1	A0<B0	X	X	X	1	0	0
A3=B3	A2=B2	A1<B1	X	X	X	X	1	0	0
A3=B3	A2<B2	X	X	X	X	X	1	0	0
A3<B3	X	X	X	X	X	X	1	0	0
X	X	X	X	X	X	0	-	-	0

X = Don't Care

BLOCK DIAGRAM

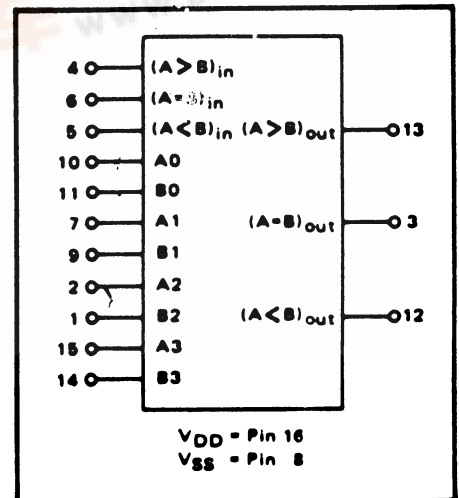

V_{DD} = Pin 16
 V_{SS} = Pin 8



ELECTRICAL CHARACTERISTICS

STATIC CHARACTERISTICS¹

PARAMETER	V _{DD} (Vdc)	CONDITIONS	T _{LOW} ²		+25°C			T _{HIGH} ²		Units
			Min.	Max.	Min.	Typ.	Max.	Min.	Max.	
QUIESCENT DRAIN CURRENT	I _{DD}	V _{IN} = V _{SS} or V _{DD} All valid input combinations	—	5	—	0.05	5	—	150	μAdc
			—	10	—	0.1	10	—	300	
			—	15	—	0.2	20	—	600	

NOTES: ¹ Remaining Static Electrical Characteristics are listed under "4000B Series Family Specifications".

² T_{LOW} = -55°C for C

= -40°C for E

T_{HIGH} = +125°C for C

= + 85°C for E

DYNAMIC CHARACTERISTICS (C_L = 50pF, T_A = 25°C)

PARAMETER		V _{DD} (Vdc)	Min.	Typ.	Max.	Units
PROPAGATION DELAY TIME	t _{PLH} , t _{PHL}	5	—	300	600	ns
		10	—	125	250	
		15	—	80	160	
OUTPUT TRANSITION TIME	t _{TLH} , t _{THL}	5	—	100	200	ns
		10	—	50	100	
		15	—	40	80	

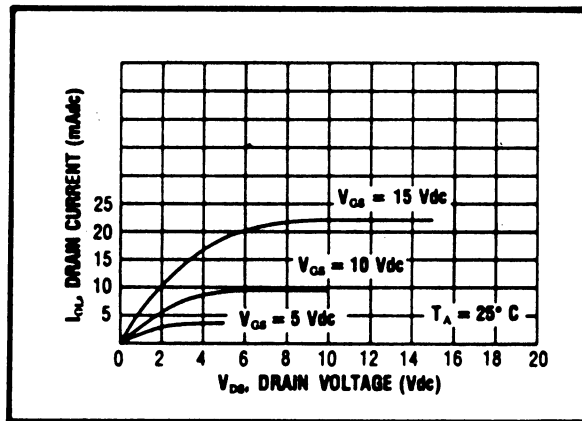

Typical N-Channel
Sink Current Characteristics

LOGIC DIAGRAM

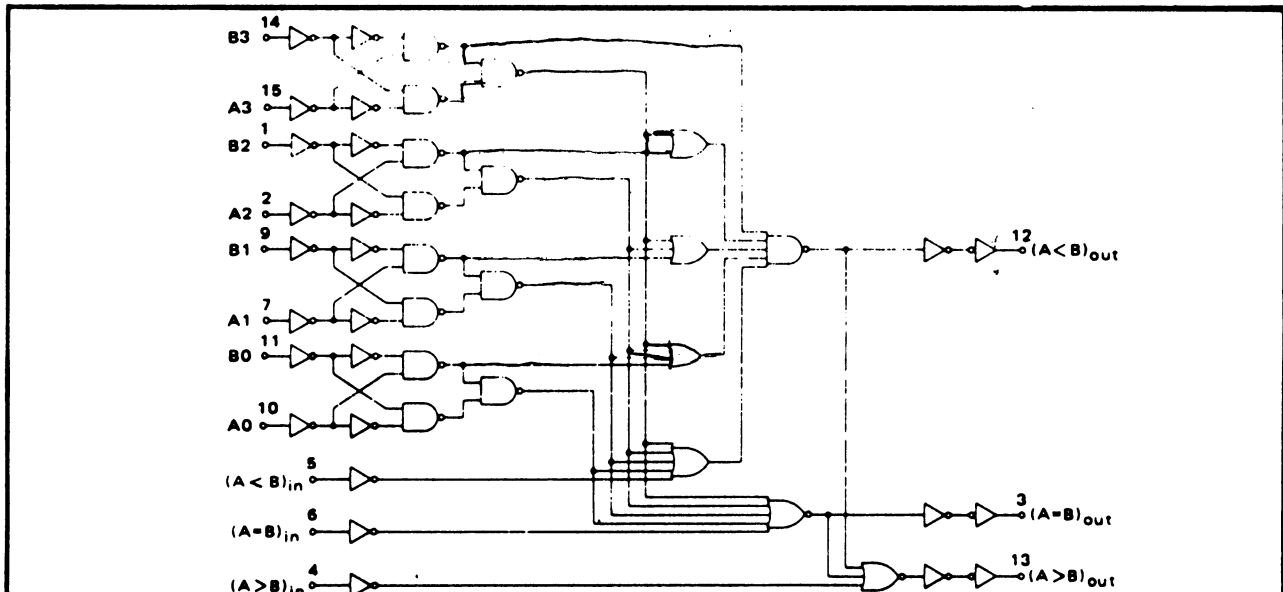

APPLICATIONS INFORMATION

COMPARISON OF TWO N-BIT WORDS

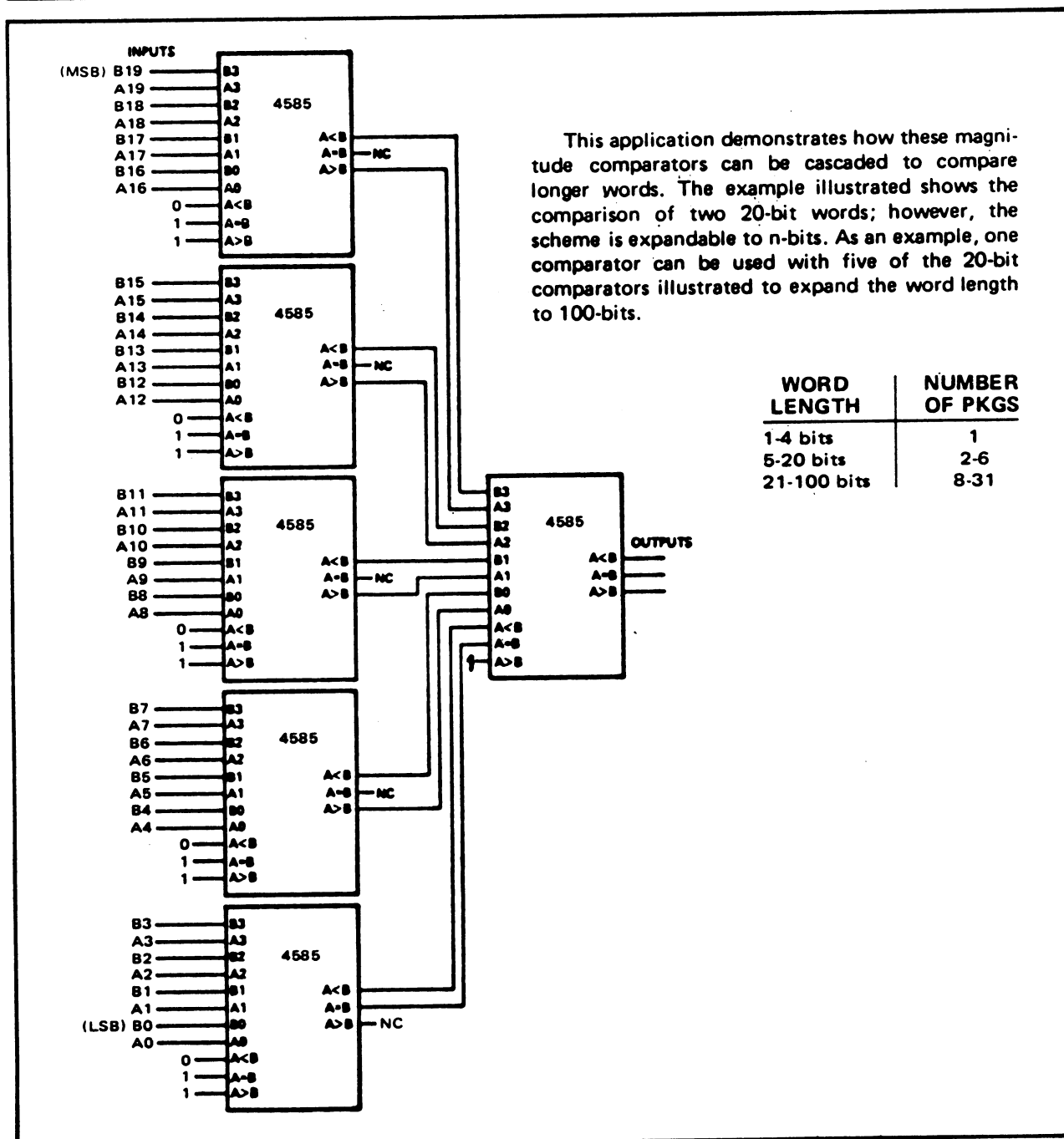
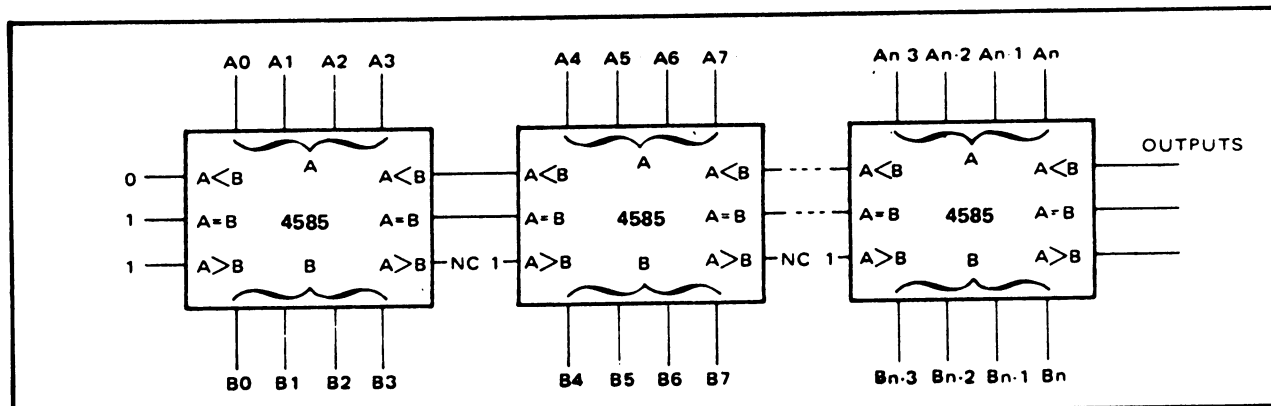

This application demonstrates how these magnitude comparators can be cascaded to compare longer words. The example illustrated shows the comparison of two 20-bit words; however, the scheme is expandable to n-bits. As an example, one comparator can be used with five of the 20-bit comparators illustrated to expand the word length to 100-bits.

WORD LENGTH	NUMBER OF PKGS
1-4 bits	1
5-20 bits	2-6
21-100 bits	8-31