



2005A

N-Channel Junction Silicon Field-Effect Transistor

T-31-25

# Video Camera Applications

©1406A

**Use**

- Video Camera

**Features**

- Large  $|y_{fs}|$
- Very low noise figure
- Small  $c_{iss}$

**Absolute Maximum Ratings/ $T_a = 25^\circ\text{C}$**

			unit
Drain to source voltage	V <sub>DSS</sub>	15	V
Gate to drain voltage	V <sub>GDS</sub>	-15	V
Gate current	I <sub>G</sub>	10	mA
Drain current	I <sub>D</sub>	50	mA
Power dissipation	P <sub>D</sub>	300	mW
Junction temperature	T <sub>j</sub>	125	°C
Storage temperature	T <sub>stg</sub>	-55 ~ +125	°C

**Electrical Characteristics/ $T_a = 25^\circ\text{C}$**

		IG = -10μA, VDS = 0V	min	typ	max	unit
Gate to drain breakdown voltage	V(BR)GDS	VGS = -10V, VDS = 0V	-15			V
Common source gate cutoff current	I <sub>GSS</sub>	VDS = 5V, VGS = 0V			-1.0	nA
Gate to source cutoff voltage	V <sub>GS(off)</sub>	VDS = 5V, I <sub>D</sub> = 100μA		-0.8	-2.2	V
Drain current (gate-source shorted)	I <sub>DSS</sub>	VDS = 5V, VGS = 0V	5.0*		38.0*	mA
Forward transfer admittance	y <sub>fs</sub>	VDS = 5V, VGS = 0V, f = 1kHz	15	27		mS
Input capacitance	c <sub>iss</sub>	VDS = 5V, VGS = 0V, f = 1MHz		7.0		pF
Feedback capacitance	c <sub>rss</sub>	VDS = 5V, VGS = 0V, f = 1MHz		2.0		pF
Noise figure	NF	VDS = 5V, R <sub>g</sub> = 1kΩ, I <sub>D</sub> = 1mA, f = 1kHz		1.5		dB

\*:The 2SK493 is classified by I<sub>DSS</sub> as follows (unit: mA):

5.0	F	12.0	10.0	G	24.0	16.0	H	38.0
-----	---	------	------	---	------	------	---	------

Case Outline 2005A  
(unit: mm)

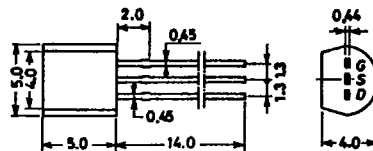

JEDEC: TO-92      G: Gate  
 EIAJ : SC-43      S: Source  
 SANYO: NP        D: Drain

[查询"2SK493"供应商](#)

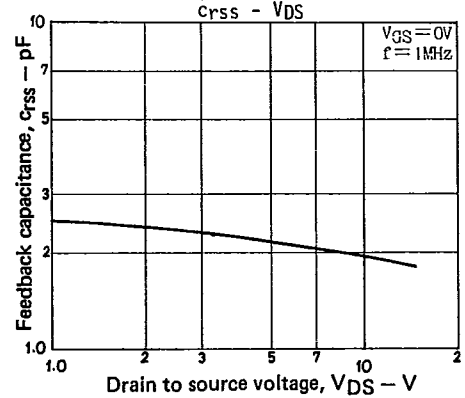
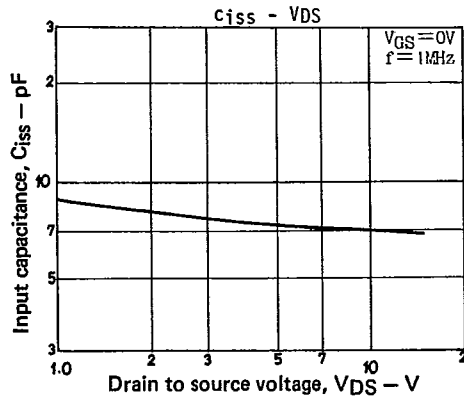
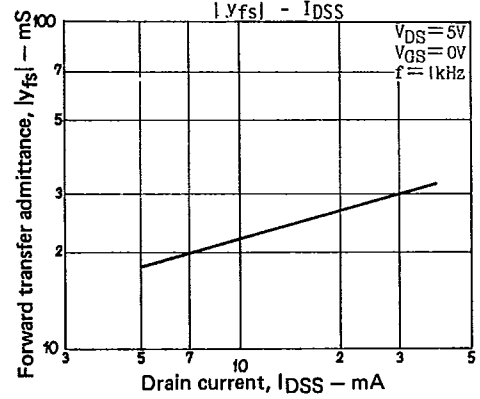
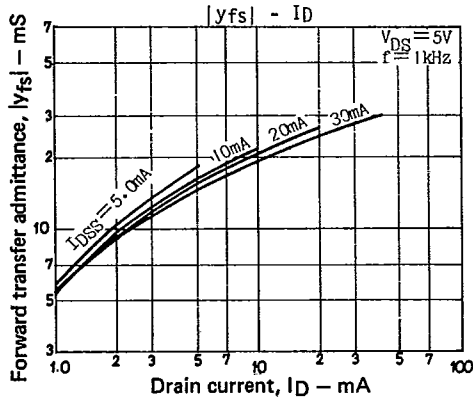
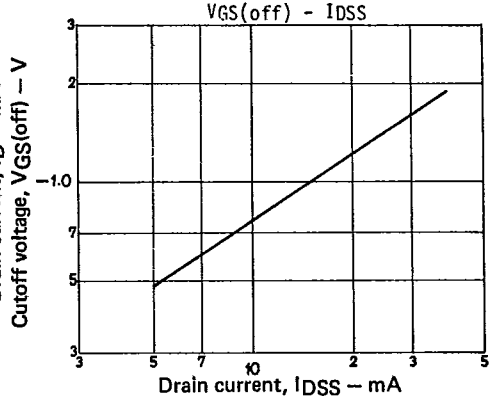
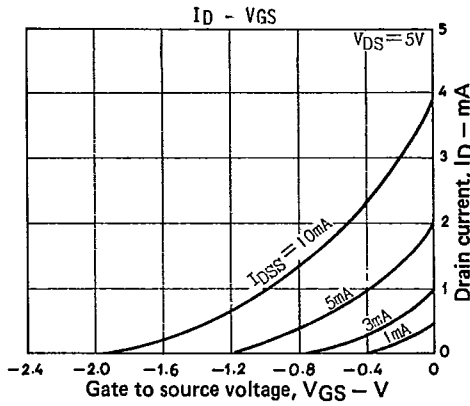
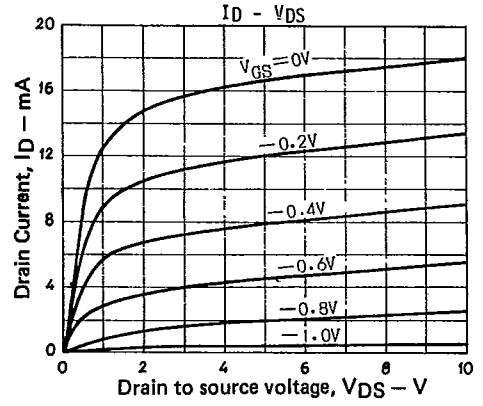
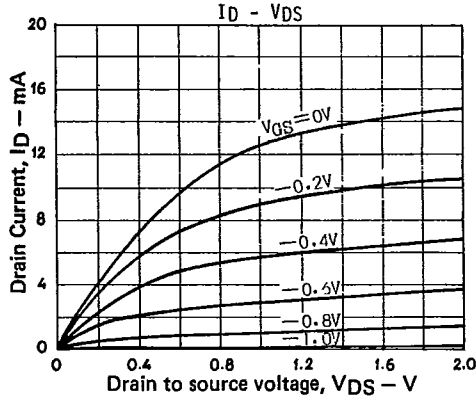

2SK493

(T-31-25)

查询"2SK493"供应商

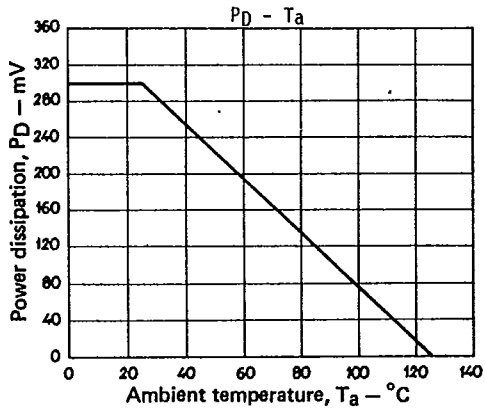
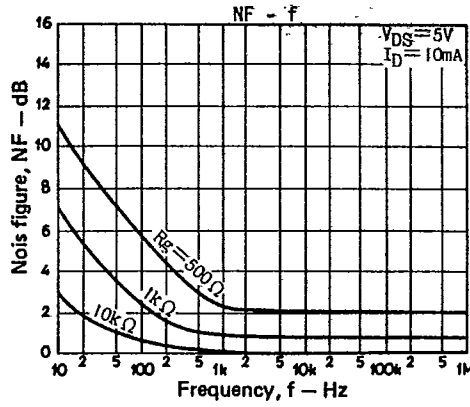
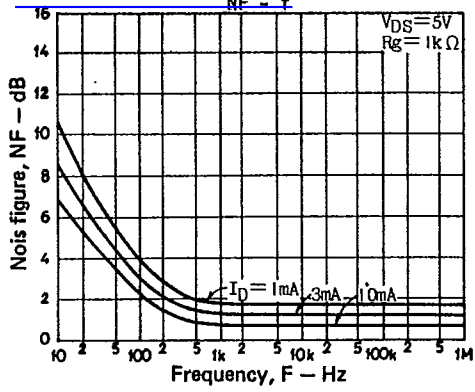

T-91-20

CASE OUTLINES AND ATTACHMENTS

[查询"2SK493"供应商](#)

- All of Sanyo Transistor case outlines are illustrated below.
- All dimensions are in mm, and dimensions which are not followed by min. or max. are represented by typical values.
- No marking is indicated.

Case Outline-[2003A]

unit:mm

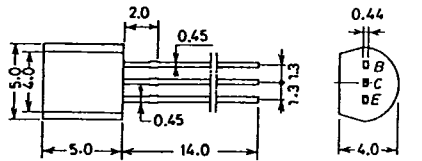

JEDEC: TO-92  
EIAJ: SC-43  
SANYO: NP

B. Base  
C. Collector  
E. Emitter

Case Outline-[2009A]

unit:mm

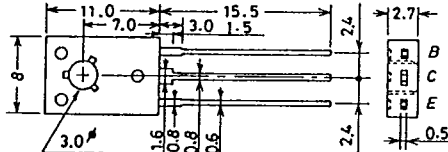

JEDEC: TO-126

B: Base  
C: Collector  
E: Emitter

Case Outline-[2004A]

unit:mm

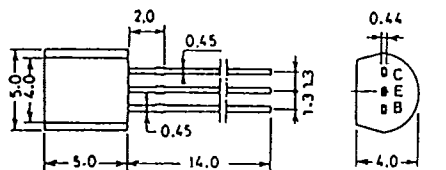

JEDEC: TO-92  
EIAJ: SC-43  
SANYO: NP

C. Collector  
E. Emitter  
B. Base

Case Outline-[2010A]

unit:mm

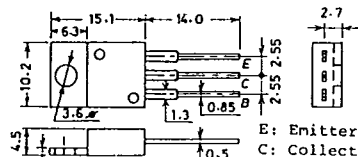

JEDEC: TO-220AB  
EIAJ: SC-46

E: Emitter  
C: Collector  
B: Base

Case Outline-[2005A]

unit:mm

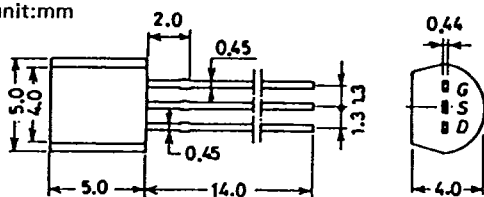

JEDEC: TO-92  
EIAJ: SC-43  
SANYO: NP

G: Gate  
S: Source  
D: Drain

Case Outline-[2012]

unit:mm

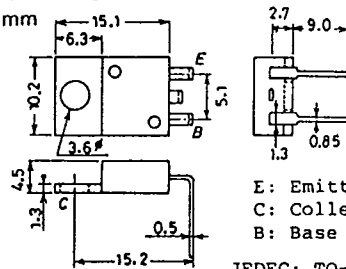

JEDEC: TO-220AA  
EIAJ: SC-45

E: Emitter  
C: Collector  
B: Base

Case Outline-[2006A]

unit:mm

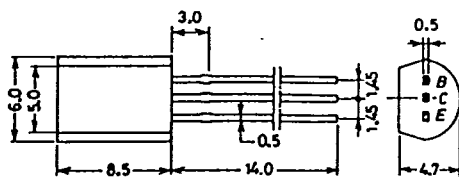

EIAJ: SC-51  
SANYO: MP

B: Base  
C: Collector  
E: Emitter

Case Outline-[2013]

unit:mm

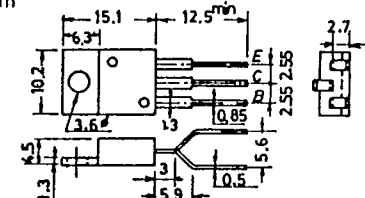

JEDEC TO-220

B: Base  
C: Collector  
E: Emitter

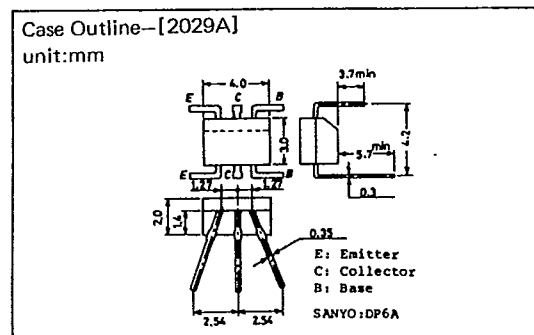
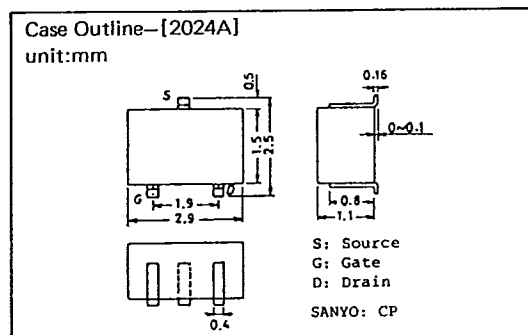
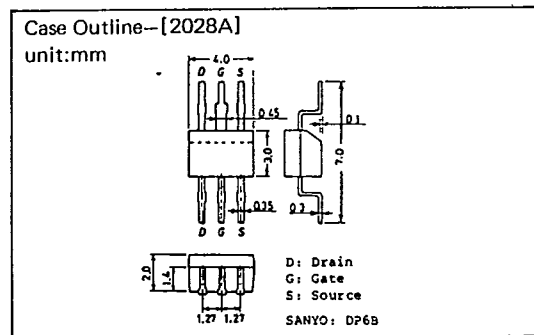
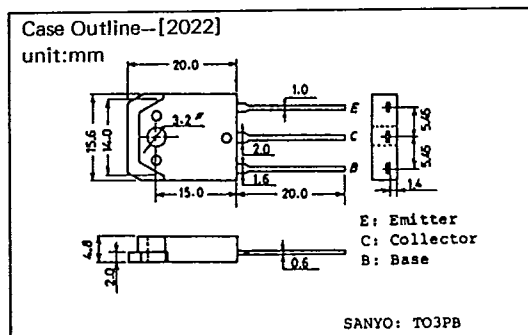
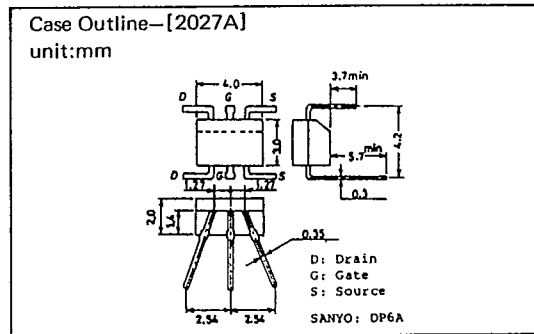
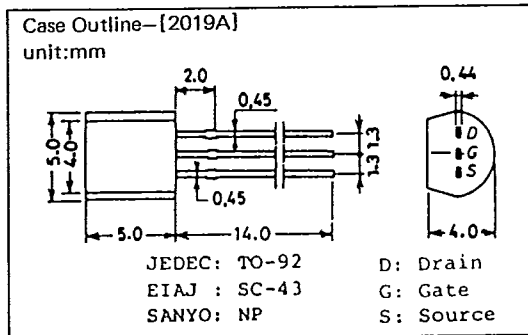
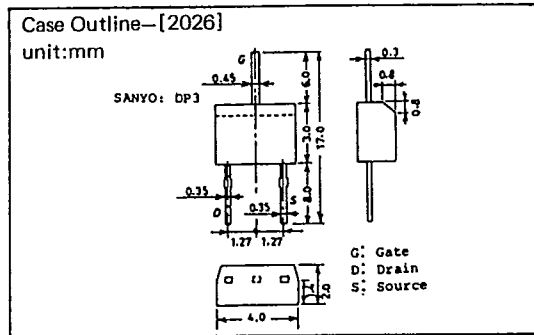
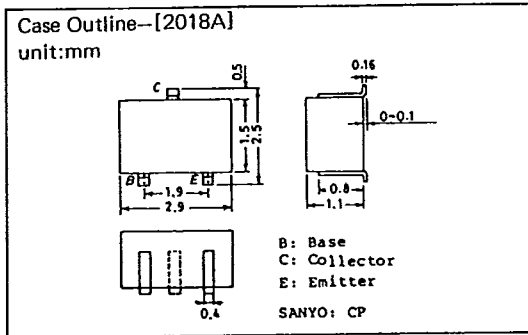
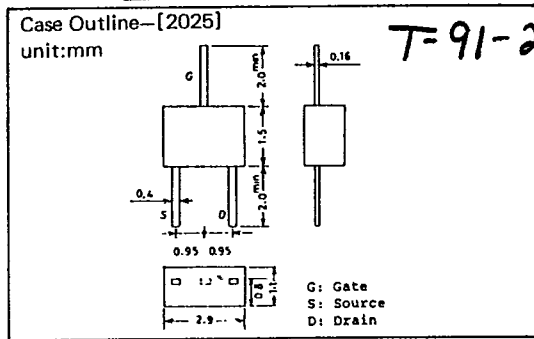
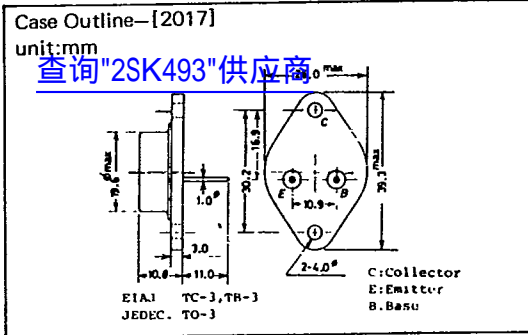

T-91-20

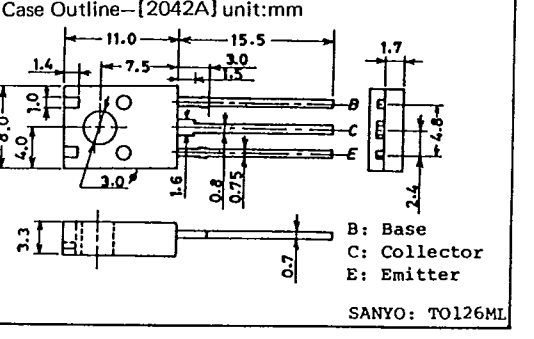
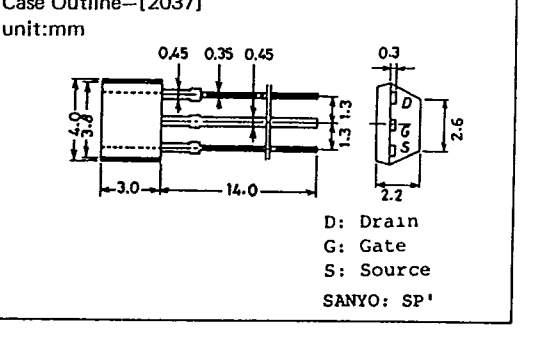
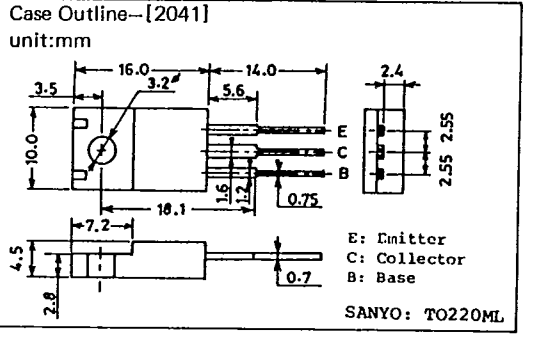
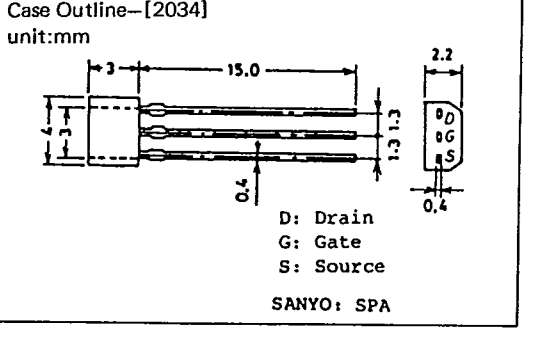
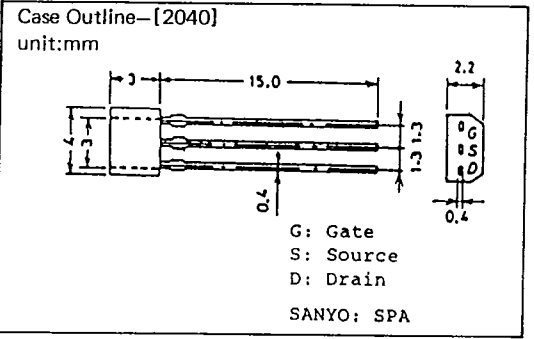
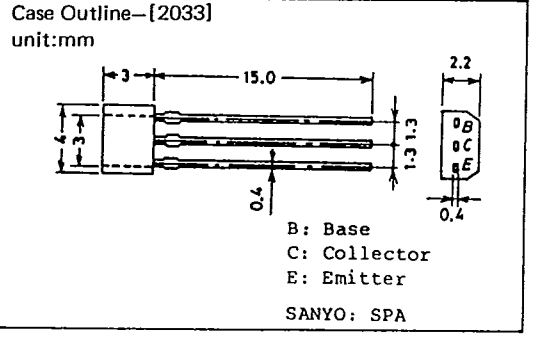
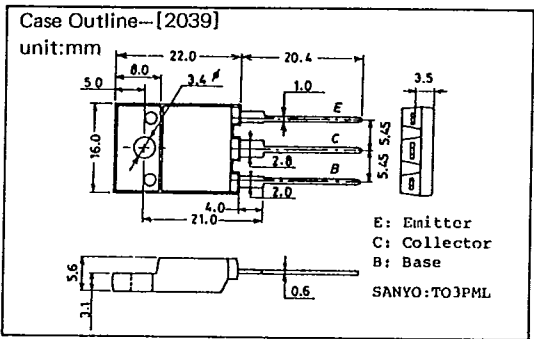
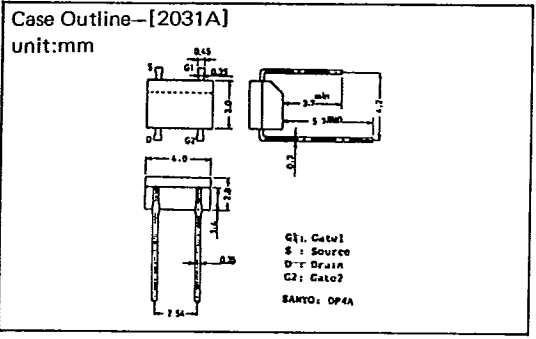
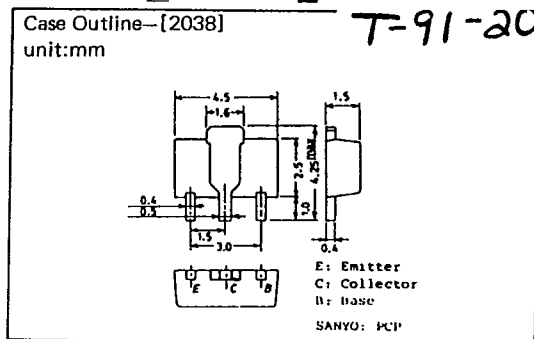
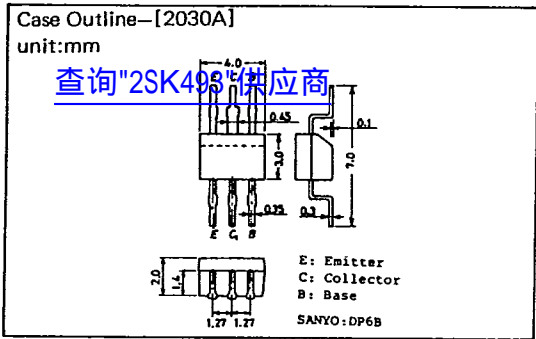

T-91-20

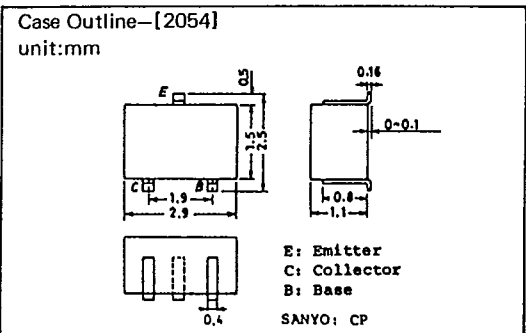
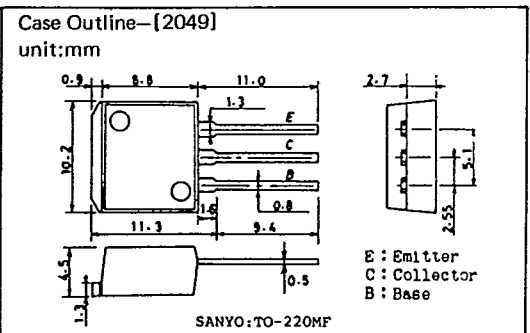
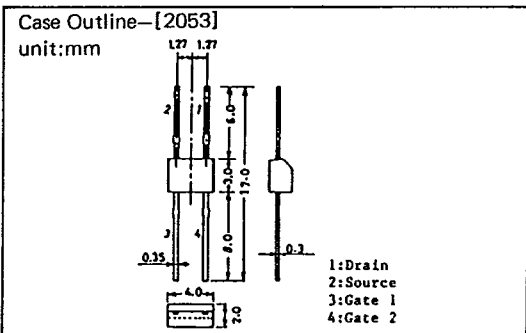
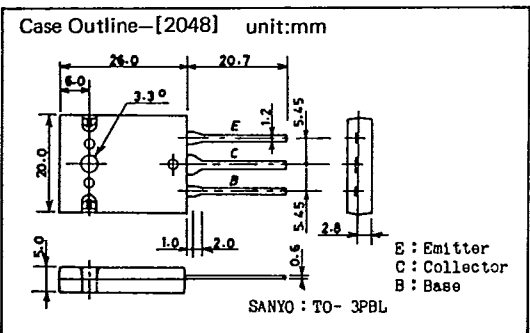
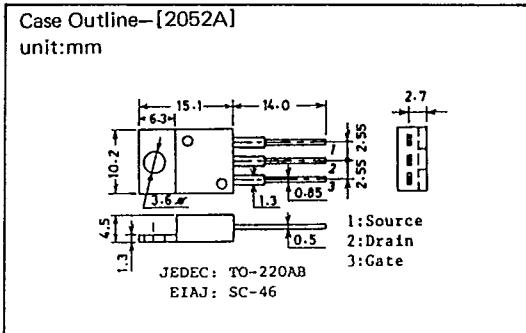
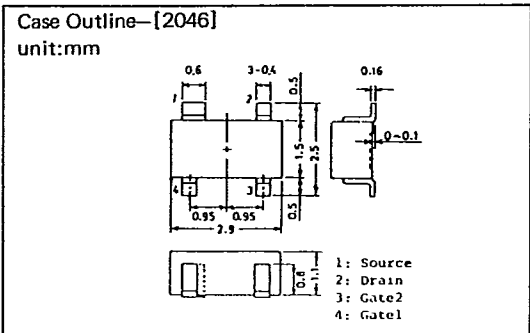
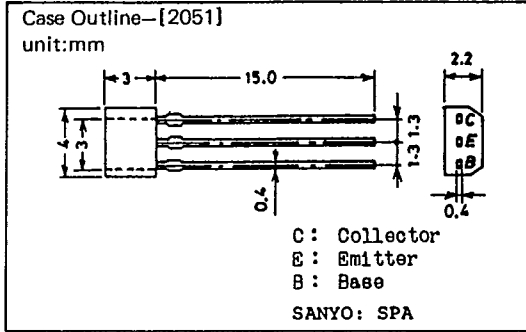
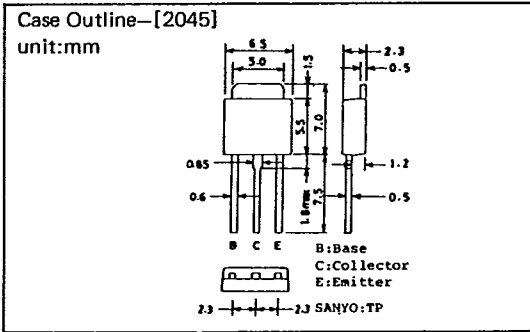
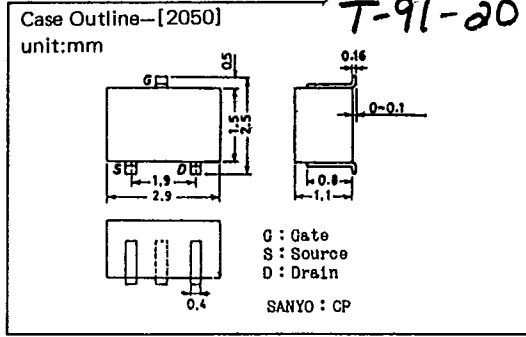
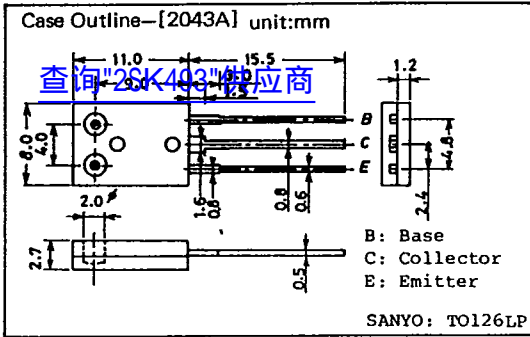

T-91-20

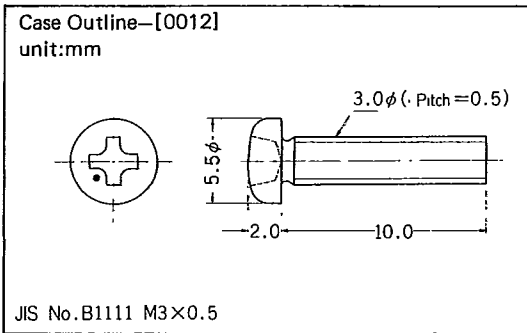
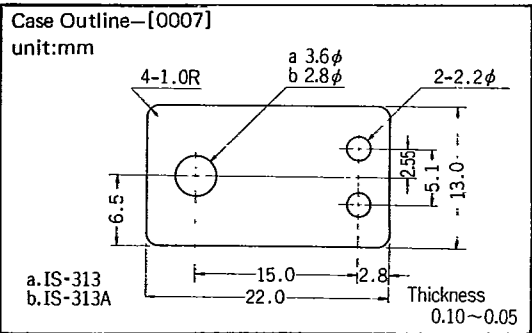
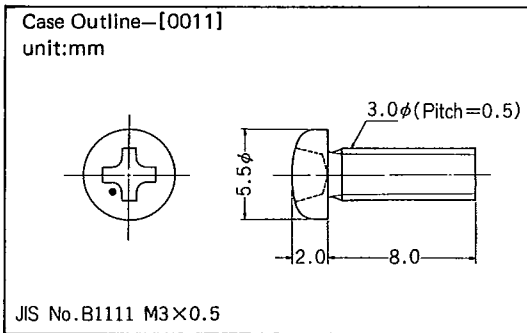
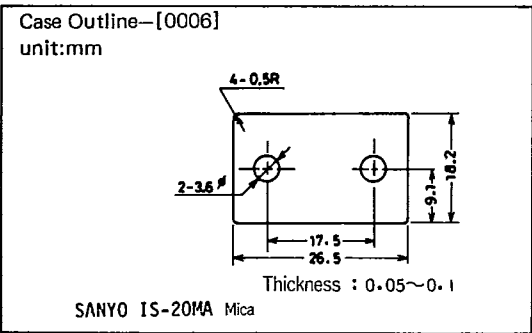
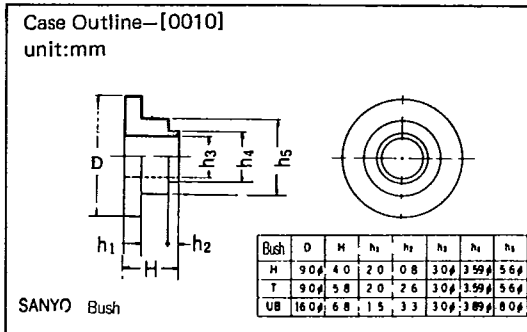
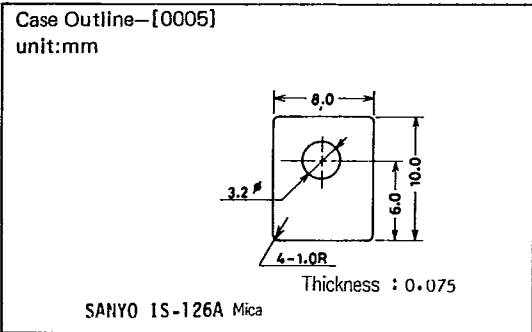
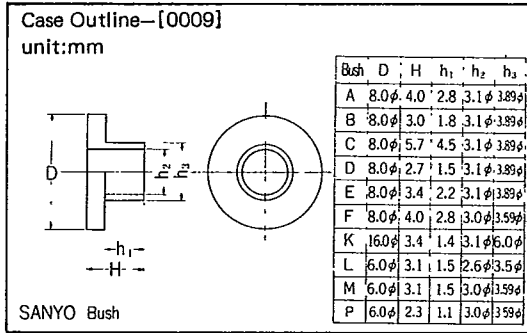
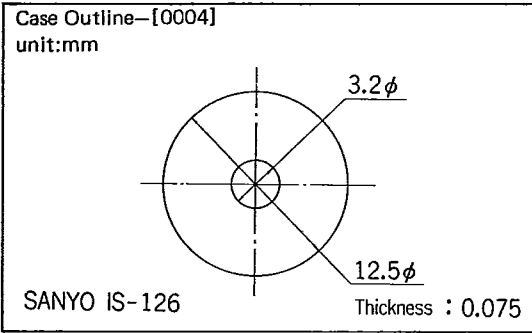
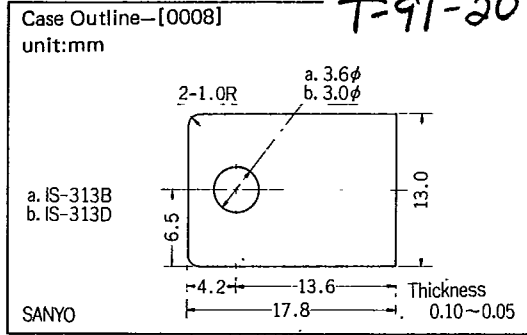
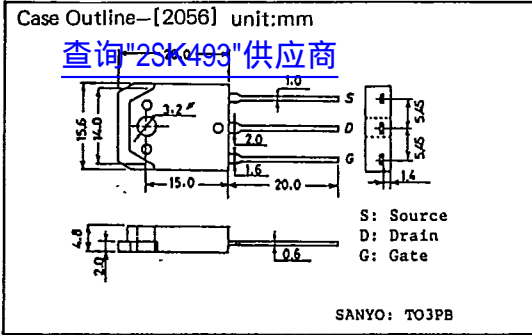



Case Outline-[0013]  
unit:mm  
[查询"2SK493"供应商](#)

JIS No. B1111 M3×0.5

Case Outline-[0018]  
unit:mm

T-91-20

SANYO Lug 1.4

Case Outline-[0014]  
unit:mm

JIS No. B1181 M3×0.5

Case Outline-[0019]  
unit:mm

SANYO Lug 1.8φ

Case Outline-[0015]  
unit:mm

JIS No. B 1251 Spring washer (M3)

Case Outline-[0020]  
unit:mm

SANYO IS-3MP Mica

Case Outline-[0016]  
unit:mm

JIS No. B1252 Flat washer

Case Outline-[0021]  
unit:mm

SANYO IS-MPC Mica

Case Outline-[0017]  
unit:mm

JIS No. G3141 Rectangular washer

Case Outline-[0022]  
unit:mm

SANYO IS-3PBL Mica