

[查询"74HCT02D-T"供应商](#)

QUAD 2-INPUT NOR GATE

FEATURES

- Output capability: standard
- I_{CC} category: SSI

GENERAL DESCRIPTION

The 74HC/HCT02 are high-speed Si-gate CMOS devices and are pin compatible with low power Schottky TTL (LSTTL). They are specified in compliance with JEDEC standard no. 7A. The 74HC/HCT02 provide the 2-input NOR function.

| SYMBOL | PARAMETER | CONDITIONS | TYPICAL | | UNIT |
|--|---|---|---------|-----|------|
| | | | HC | HCT | |
| t _{PHL} / t _{PLH} | propagation delay nA, nB to nY | C _L = 15 pF V _{CC} = 5 V | 7 | 9 | ns |
| C _I | input capacitance | | 3.5 | 3.5 | pF |
| CPD | power dissipation capacitance per gate | notes 1 and 2 | 22 | 24 | pF |

GND = 0 V; T_{amb} = 25 °C; t_r = t_f = 6 ns

Notes

1. CPD is used to determine the dynamic power dissipation (P_D in μW):

$$P_D = CPD \times V_{CC}^2 \times f_i + \sum (C_L \times V_{CC}^2 \times f_o)$$
 where:
 f_i = input frequency in MHz C_L = output load capacitance in pF
 f_o = output frequency in MHz V_{CC} = supply voltage in V
 Σ (C_L × V_{CC}² × f_o) = sum of outputs
2. For HC the condition is V_I = GND to V_{CC}
 For HCT the condition is V_I = GND to V_{CC} - 1.5 V

PACKAGE OUTLINES

14-lead DIL; plastic (SOT27)
 14-lead mini pack; plastic (SO14; SOT108A)

PIN DESCRIPTION

| PIN NO. | SYMBOL | NAME AND FUNCTION |
|--------------|-----------------|-------------------------|
| 1, 4, 10, 13 | 1Y to 4Y | data outputs |
| 2, 5, 8, 11 | 1A to 4A | data inputs |
| 3, 6, 9, 12 | 1B to 4B | data inputs |
| 7 | GND | ground (0 V) |
| 14 | V _{CC} | positive supply voltage |

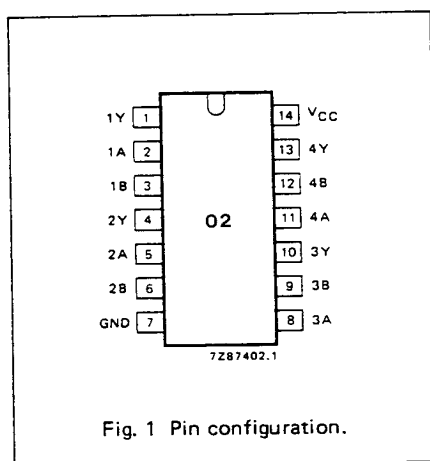

Fig. 1 Pin configuration.

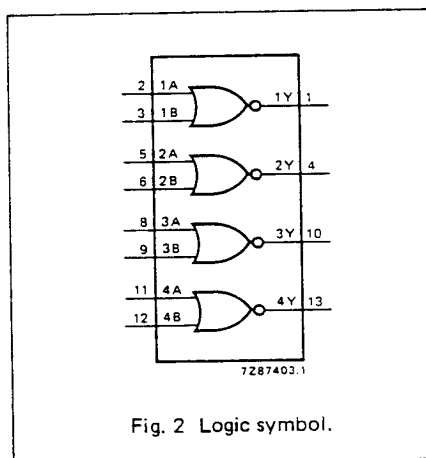

Fig. 2 Logic symbol.

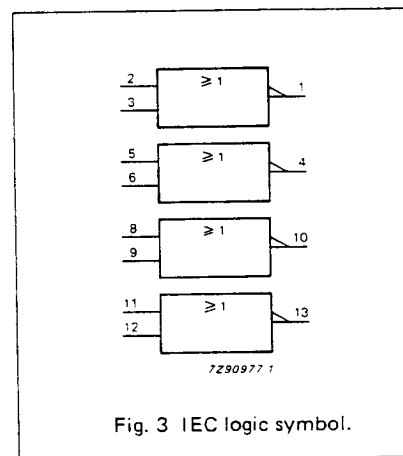
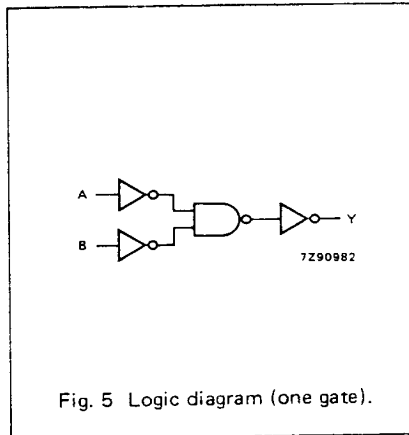
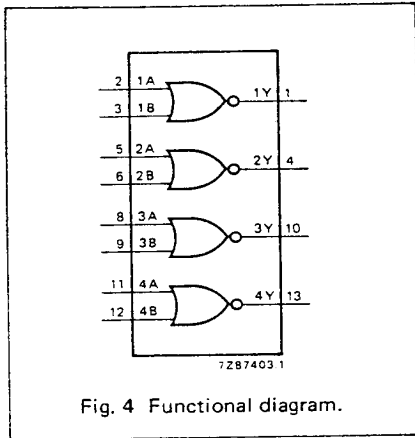

Fig. 3 IEC logic symbol.

[查询"74HCT02D-T"供应商](#)



FUNCTION TABLE

| INPUTS | | OUTPUT |
|--------|----|--------|
| nA | nB | nY |
| L | L | H |
| L | H | L |
| H | L | L |
| H | H | L |

H = HIGH voltage level
L = LOW voltage level

DC CHARACTERISTICS FOR 74HC

For the DC characteristics see chapter "HCMOS family characteristics", section "Family specifications".

Output capability: standard
I_{CC} category: SSI

AC CHARACTERISTICS FOR 74HC

GND = 0 V; t_r = t_f = 6 ns; C_L = 50 pF

| SYMBOL | PARAMETER | T _{amb} (°C) | | | | | | UNIT | TEST CONDITIONS | | |
|--|-----------------------------------|-----------------------|--------------|----------------|------------|-----------------|-------------|-----------------|----------------------|-------------------|--------|
| | | 74HC | | | | | | | V _{CC} V | WAVEFORMS | |
| | | +25 | | | -40 to +85 | | -40 to +125 | | | | |
| | | min. | typ. | max. | min. | max. | min. | | max. | | |
| t _{PHL} / t _{PLH} | propagation delay nA, nB to nY | | 25 9 7 | 90 18 15 | | 115 23 20 | | 135 27 23 | ns | 2.0 4.5 6.0 | Fig. 6 |
| t _{THL} / t _{TLH} | output transition time | | 19 7 6 | 75 15 13 | | 95 19 16 | | 110 22 19 | ns | 2.0 4.5 6.0 | Fig. 6 |

[查询"74HCT02D-T"供应商](#)**DC CHARACTERISTICS FOR 74HCT**

For the DC characteristics see chapter "HCMOS family characteristics", section "Family specifications".

Output capability: standard

I_{CC} category: SSI

Note to HCT types

The value of additional quiescent supply current (ΔI_{CC}) for a unit load of 1 is given in the family specifications. To determine ΔI_{CC} per input, multiply this value by the unit load coefficient shown in the table below.

| INPUT | UNIT LOAD COEFFICIENT |
|--------|-----------------------|
| nA, nB | 1.50 |

AC CHARACTERISTICS FOR 74HCT

GND = 0 V; $t_r = t_f = 6$ ns; $C_L = 50$ pF

| SYMBOL | PARAMETER | T_{amb} (°C) | | | | | | UNIT | TEST CONDITIONS | | |
|-------------------|-----------------------------------|----------------|------|------|------------|------|-------------|------|-----------------|-----------|--------|
| | | 74HCT | | | | | | | V_{CC} V | WAVEFORMS | |
| | | +25 | | | -40 to +85 | | -40 to +125 | | | | |
| | | min. | typ. | max. | min. | max. | min. | | | | max. |
| t_{PHL}/t_{PLH} | propagation delay nA, nB to nY | | 11 | 19 | | 24 | | 29 | ns | 4.5 | Fig. 6 |
| t_{THL}/t_{TLH} | output transition time | | 7 | 15 | | 19 | | 22 | ns | 4.5 | Fig. 6 |

AC WAVEFORMS

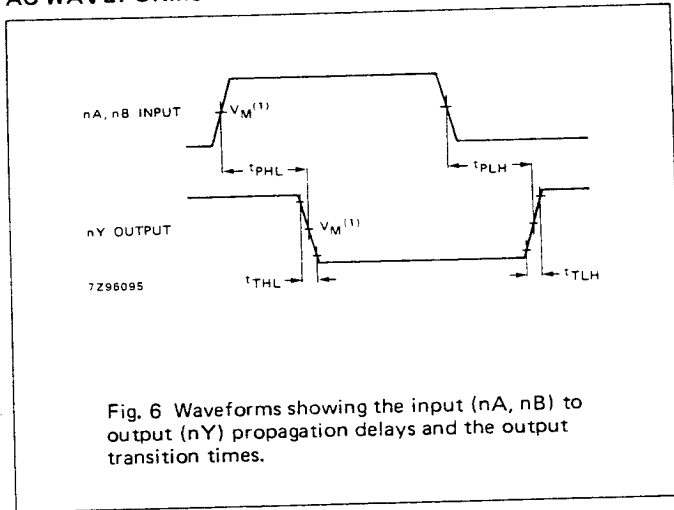

Note to AC waveforms

- (1) HC : $V_M = 50\%$; $V_I = \text{GND to } V_{CC}$.
 HCT: $V_M = 1.3 \text{ V}$; $V_I = \text{GND to } 3 \text{ V}$.