

Overvoltage and Overcurrent Protection IC and Li+ Charger Front-End Protection IC With LDO Mode

FEATURES

- Input Overvoltage Protection
- Accurate Battery Overvoltage Protection
- Output Short-Circuit Protection
- Soft-Start to Prevent Inrush Currents
- Soft-Stop to Prevent Voltage Spikes
- 30-V Maximum Input Voltage
- Supports up to 1.7-A Load Current
- Thermal Shutdown
- Enable Function
- Fault Status Indication
- Small 2 mm × 2 mm 8-Pin SON Package

APPLICATIONS

- Smart Phones, Mobile Phones
- PDAs
- MP3 Players
- Low-Power Handheld Devices

DESCRIPTION

The bq2438x family are charger front-end integrated circuits designed to provide protection to Li-ion batteries from failures of the charging circuitry. The IC continuously monitors the input voltage and the battery voltage. The device operates like a linear regulator, maintaining a 5.5-V (bq24380) or 5-V (bq24381) output with input voltages up to the Input overvoltage threshold. During input overvoltage conditions, the IC immediately turns off the internal pass FET disconnecting the charging circuitry from the damaging input source. Additionally, if the battery voltage rises to unsafe levels while charging, power is removed from the system. The IC checks for short-circuit or overload conditions at its output when turning the pass FET on, and if it finds unsafe conditions, it switches off, and then rechecks the conditions. Additionally, the IC also monitors its die temperature and switches off if it exceeds 140°C.

When the IC is controlled by a processor, the IC provides status information about fault conditions to the host.

APPLICATION SCHEMATIC

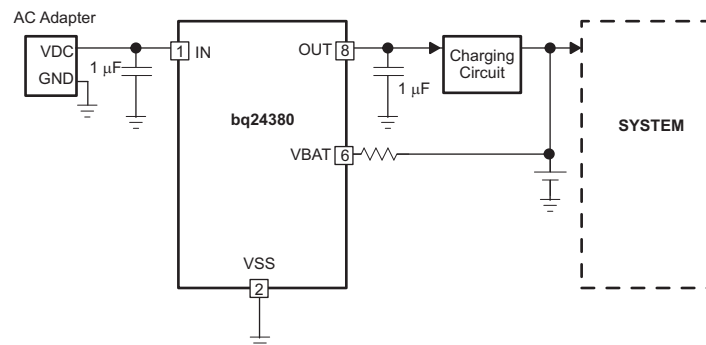

Please be aware that an important notice concerning availability, standard warranty, and use in critical applications of Texas Instruments semiconductor products and disclaimers thereto appears at the end of this data sheet.

PowerPAD is a trademark of Texas Instruments.



These devices have limited built-in ESD protection. The leads should be shorted together or the device placed in conductive foam during storage or handling to prevent electrostatic damage to the MOS gates.

ORDERING INFORMATION

DEVICE	V _{OVP}	V _{O(REG)}	PACKAGE ⁽¹⁾	MARKING
bq24380	6.3 V	5.5 V	2x2 SON	CFE
bq24381	7.1 V	5 V	2x2 SON	CFW

(1) For the most current package and ordering information, see the Package Option Addendum at the end of this document, or see the TI Web site at www.ti.com.

ABSOLUTE MAXIMUM RATINGS⁽¹⁾

over operating free-air temperature range (unless otherwise noted)

		VALUE	UNIT	
V _I	Input voltage	IN (with respect to VSS)	-0.3 to 30	V
		OUT (with respect to VSS)	-0.3 to 12	V
		FAULT, CE, VBAT (with respect to VSS)	-0.3 to 7	V
I _{OUTmax}	Output source current	OUT	2	A
	Output sink current	FAULT	15	mA
T _J	Junction temperature		-40 to 150	°C
T _{stg}	Storage temperature		-65 to 150	°C

(1) Stresses beyond those listed under absolute maximum ratings may cause permanent damage to the device. These are stress ratings only, and functional operation of the device at these or any other conditions beyond those indicated under recommended operating conditions is not implied. Exposure to absolute-maximum-rated conditions for extended periods may affect device reliability. All voltage values are with respect to the network ground terminal unless otherwise noted.

DISSIPATION RATINGS

PACKAGE	R _{θJC}	R _{θJA}
DSG	5°C/W	75°C/W

RECOMMENDED OPERATING CONDITIONS

		MIN	MAX	UNIT
V _I	IN voltage range	3.3	30	V
I _O	Current, OUT pin		1.7	A
T _J	Junction temperature	-40	125	°C

ELECTRICAL CHARACTERISTICS

 Over junction temperature range $-40^{\circ}\text{C} \leq T_J \leq 125^{\circ}\text{C}$ and recommended supply voltage (unless otherwise noted)

PARAMETER		TEST CONDITIONS	MIN	TYP	MAX	UNIT	
IN							
UVLO	Undervoltage lock-out, input power detected threshold	$\overline{\text{CE}} = \text{LO or HI}, V_{\text{IN}}: 0 \text{ V} \rightarrow 3 \text{ V}$	2.5		2.8	V	
$V_{\text{hys}}(\text{UVLO})$	Hysteresis on UVLO	$\overline{\text{CE}} = \text{LO or HI}, V_{\text{IN}}: 3 \text{ V} \rightarrow 0 \text{ V}$	200		300	mV	
$t_{\text{DGL}}(\text{PGOOD})$	Deglitch time, input power detected status	$\overline{\text{CE}} = \text{LO or HI}$. Time measured from $V_{\text{IN}} 0 \text{ V} \rightarrow 5 \text{ V}$ 1- μs rise-time		8		ms	
I_{DD}	Operating current	$\overline{\text{CE}} = \text{LO}$, no load on OUT pin, $V_{\text{IN}} = 5 \text{ V}$			250 300	μA	
I_{STDBY}	Standby current	$\overline{\text{CE}} = \text{HI}, V_{\text{IN}} = 5.5 \text{ V}$			100	μA	
INPUT-TO-OUTPUT CHARACTERISTICS							
V_{DO}	Dropout voltage IN to OUT	$\overline{\text{CE}} = \text{LO}, V_{\text{IN}} = 5 \text{ V}, I_{\text{(OUT)}} = 1 \text{ A}$			280	mV	
I_{OFF}	Q1 off-state leakage current	$\overline{\text{CE}} = \text{HI}, V_{\text{IN}} = 5.5 \text{ V}$			10	μA	
INPUT OVERVOLTAGE PROTECTION							
$V_{\text{O(REG)}}$	Output voltage	$\overline{\text{CE}} = \text{LO}, V_{\text{IN}} = 6 \text{ V}$	bq24380 4.8	5.3 5	5.5 5.2	V	
V_{OVP}	Input overvoltage protection threshold	$\overline{\text{CE}} = \text{LO}, V_{\text{IN}}: 5 \text{ V} \rightarrow 7 \text{ V}$ $\overline{\text{CE}} = \text{LO}, V_{\text{IN}}: 5 \text{ V} \rightarrow 8 \text{ V}$	bq24380 bq24831	6.1 6.88	6.3 7.10	6.5 7.31	V
$V_{\text{hys}}(\text{OVP})$	Hysteresis on OVP	$\overline{\text{CE}} = \text{LO or HI}, V_{\text{IN}}: 7 \text{ V} \rightarrow 5 \text{ V}$ $\overline{\text{CE}} = \text{LO or HI}, V_{\text{IN}}: 8 \text{ V} \rightarrow 5 \text{ V}$	bq24380 bq24831	25 25		110 120	mV
$t_{\text{PD}}(\text{OVP})^{(1)}$	Input OV propagation delay	$V_{\text{IN}}: 5 \text{ V} \rightarrow 10 \text{ V}$		200		ns	
$t_{\text{REC}}(\text{OVP})$	Recovery time from input overvoltage condition	$\overline{\text{CE}} = \text{LO}$. Time measured from $V_{\text{IN}}: 7 \text{ V} \rightarrow 5 \text{ V}$, 1- μs fall-time		8		ms	
OUTPUT SHORT-CIRCUIT PROTECTION (only at start-up)							
$I_{\text{O(SC)}}$	Short-circuit detection threshold	$3 \text{ V} < V_{\text{IN}} < V_{\text{OVP}} - V_{\text{hys}}(\text{OVP})$	1.3	1.5	1.7	A	
$t_{\text{REC}}(\text{SC})$	Retry interval if short-circuit detected			64		ms	
BATTERY OVERVOLTAGE PROTECTION							
BV_{OVP}	Battery overvoltage protection threshold	$V_{\text{IN}} > 4.5 \text{ V}, \overline{\text{CE}} = \text{LO}$	4.3	4.35	4.4	V	
$V_{\text{hys}}(\text{BVovp})$	Hysteresis on BV_{OVP}	$V_{\text{IN}} > 4.5 \text{ V}, \overline{\text{CE}} = \text{LO}$	200		320	mV	
$I_{\text{(VBAT)}}$	Input bias current on VBAT pin	$T_J = 25^{\circ}\text{C}$			10	nA	
$t_{\text{DGL}}(\text{BVovp})$	Deglitch time, battery overvoltage detected	$V_{\text{IN}} > 4.5 \text{ V}, \overline{\text{CE}} = \text{LO}$, Time measured from V_{VSAT} rising from 4.1 V to 4.4 V to FAULT going low.		176		μs	
THERMAL PROTECTION							
$T_{\text{J(OFF)}}$	Thermal shutdown temperature			140	150	$^{\circ}\text{C}$	
$T_{\text{J(OFF-HYS)}}$	Thermal shutdown hysteresis			20		$^{\circ}\text{C}$	
LOGIC LEVELS ON $\overline{\text{CE}}$							
V_{IL}	Logic LOW input voltage		0		0.4	V	
V_{IH}	Logic HIGH input voltage		1.4			V	
I_{IL}					1	μA	
I_{IH}		$V_{\text{CE}} = 1.8 \text{ V}$			15	μA	
LOGIC LEVELS ON FAULT							
V_{OL}	Output LOW voltage	$I_{\text{SINK}} = 5 \text{ mA}$			0.2	V	
I_{IKg}	Off-state leakage current, HI-Z	$V_{\text{FAULT}} = 5 \text{ V}$			10	μA	

(1) Not tested. Specified by design

DEVICE INFORMATION

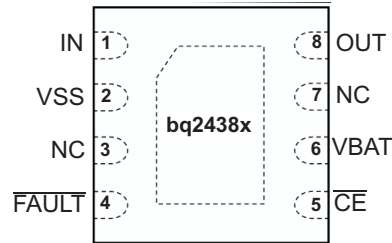

TERMINAL FUNCTIONS

TERMINAL		I/O	DESCRIPTION
NAME	NO.		
IN	1	I	Input power, connected to external DC supply. Bypass IN to VSS with a ceramic capacitor (1 μ F minimum)
VSS	2	-	Ground terminal. Connect to the thermal pad and to the ground rail of the circuit.
NC	3, 7		Do not connect to any external circuits. These pins may have internal connections used for test purposes.
$\overline{\text{FAULT}}$	4	O	Open-drain device status output. $\overline{\text{FAULT}}$ is pulled to VSS internally when the input pass FET has been turned off due to input overvoltage or output short-circuit conditions, an overtemperature condition, or because the battery voltage is outside safe limits. $\overline{\text{FAULT}}$ is high impedance during normal operation.
$\overline{\text{CE}}$	5	I	Active-low chip enable input. Connect $\overline{\text{CE}} = \text{HI}$ to turn the input pass FET off. Connect $\overline{\text{CE}} = \text{LOW}$ to turn the internal pass FET on and connect the input to the charging circuitry. $\overline{\text{CE}}$ is Internally pulled down, $\sim 200 \text{ k}\Omega$.
VBAT	6	I	Battery voltage sense input. Connected to pack positive terminal through a 100-k Ω resistor.
OUT	8	O	Output terminal to the charging system. Bypass OUT to VSS with a ceramic capacitor (1 μ F minimum)
Thermal PAD			The thermal pad is electrically connected to VSS internally. The thermal pad must be connected to the same potential as the VSS pin on the printed circuit board. Do not use the thermal pad as the primary ground input for the device. VSS pin must be connected to ground at all times.

TYPICAL CHARACTERISTICS

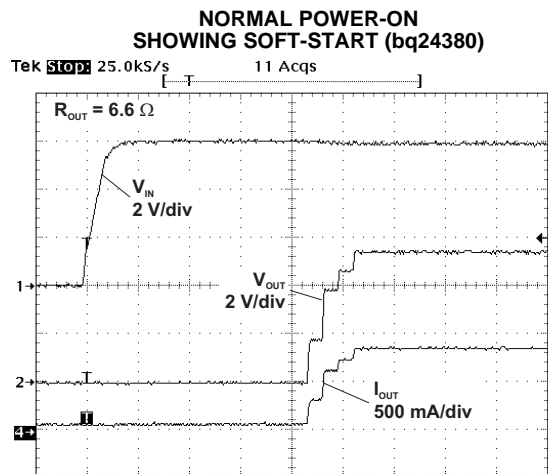

t - Time - 2 ms/div
Figure 1.

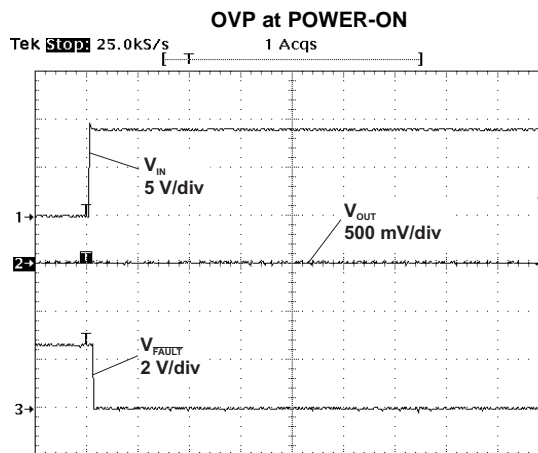

t - Time - 2 ms/div
Figure 2.

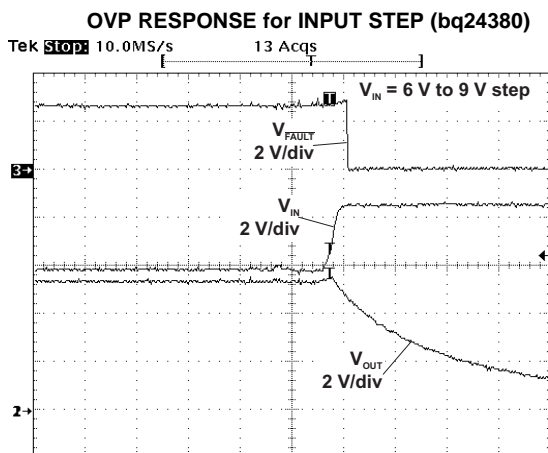

t - Time - 5 μ s/div
Figure 3.

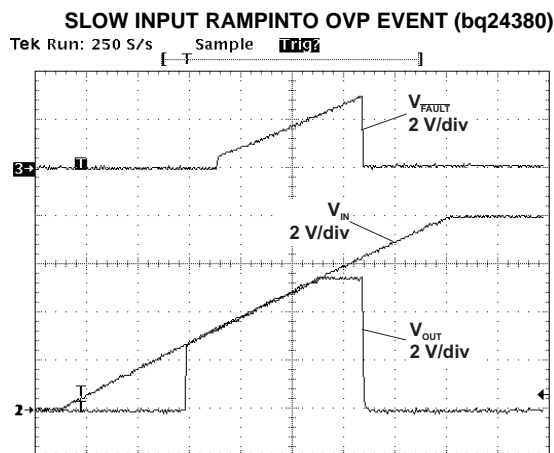

t - Time - 200 ms/div
Figure 4.

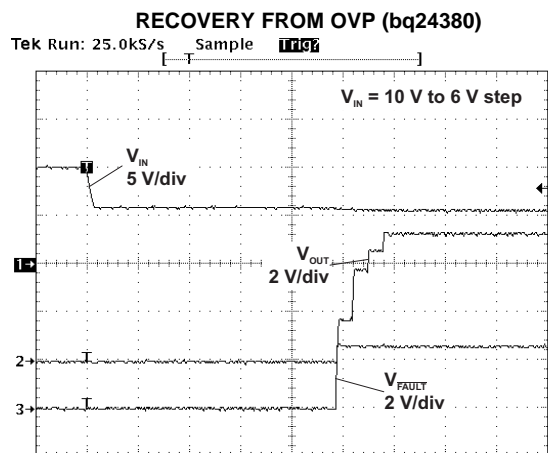

t - Time - 2 ms/div
Figure 5.

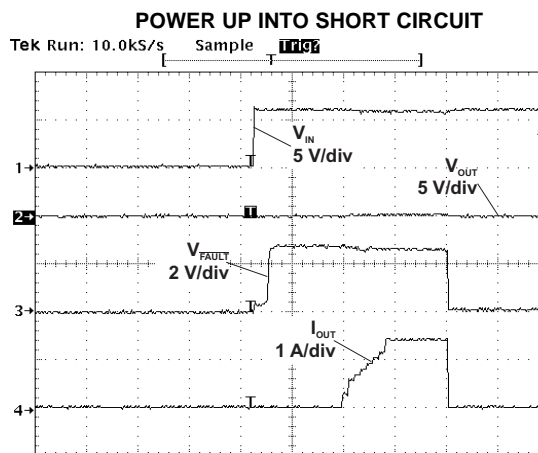

t - Time - 5 ms/div
Figure 6.

TYPICAL CHARACTERISTICS (continued)

SOFT-STOP DURING OCP EVENT (bq24380)

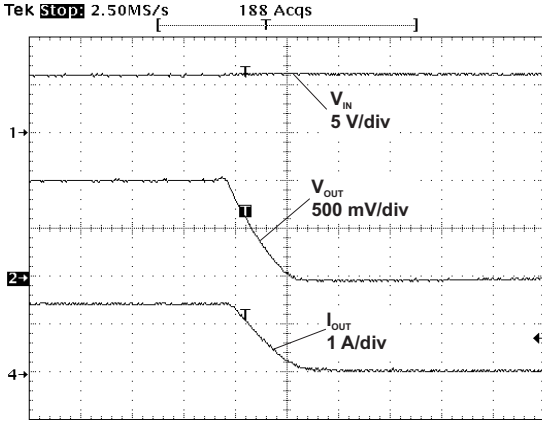

t - Time - 20 μ s/div

Figure 7.

BATTERY OVP EVENT (bq24380)

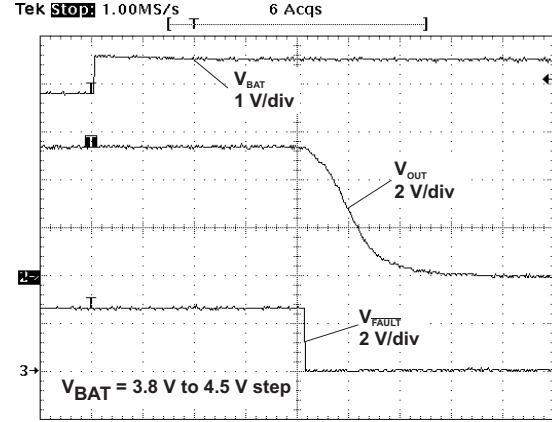

t - Time - 50 μ s/div

Figure 8.

UVLO
VS
FREE-AIR TEMPERATURE

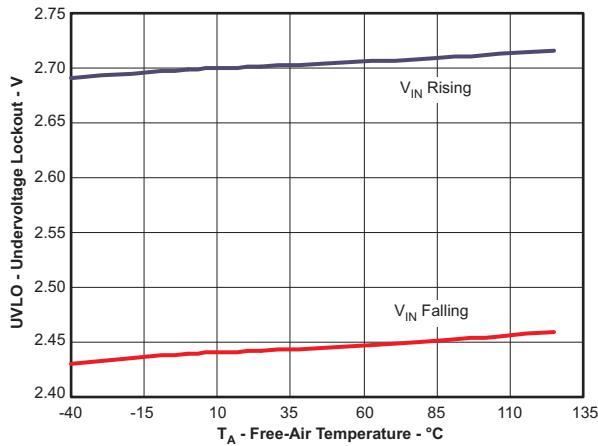

Figure 9.

DROPOUT VOLTAGE
VS
FREE-AIR TEMPERATURE

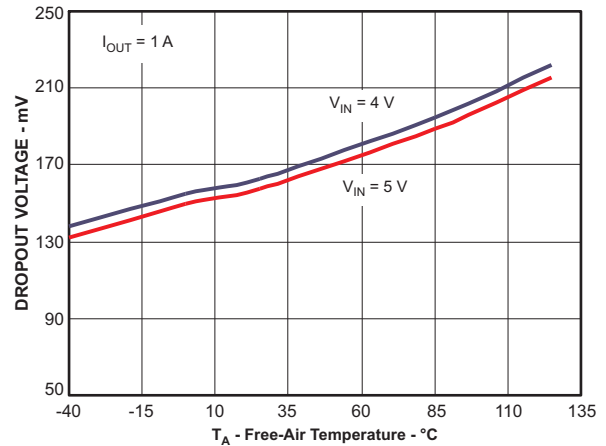

Figure 10.

OUTPUT VOLTAGE REGULATION, $V_{O(REG)}$
VS
FREE-AIR TEMPERATURE

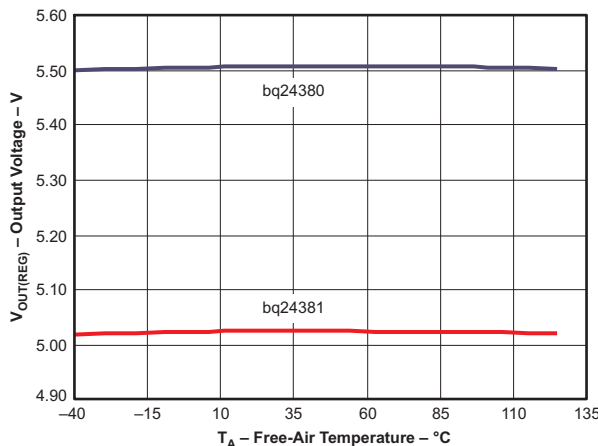

Figure 11.

OVP THRESHOLD
VS
FREE-AIR TEMPERATURE

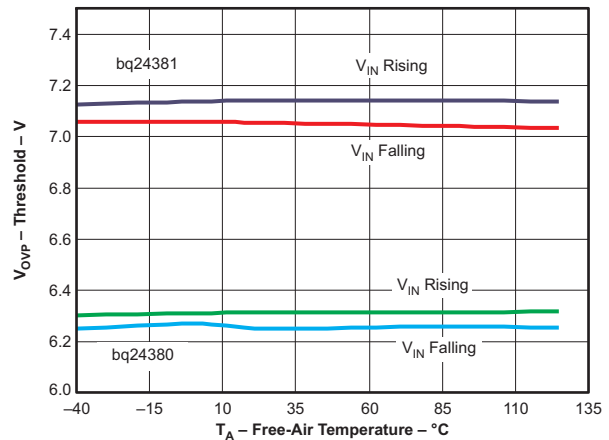

Figure 12.

TYPICAL CHARACTERISTICS (continued)

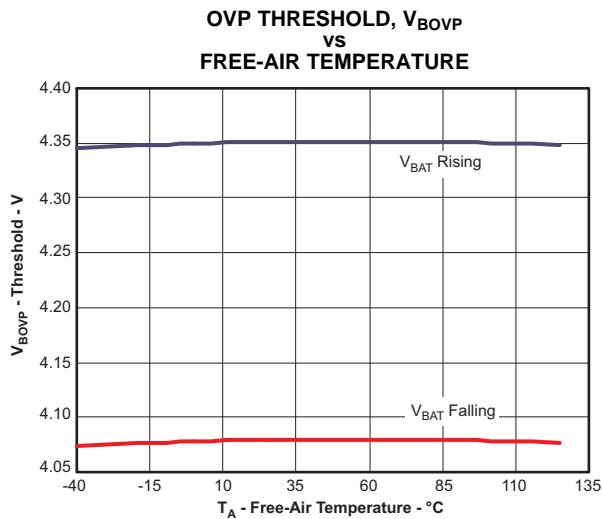

Figure 13.

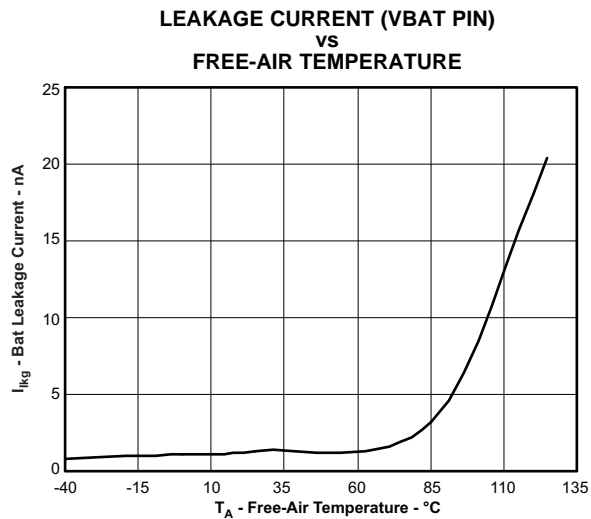

Figure 14.

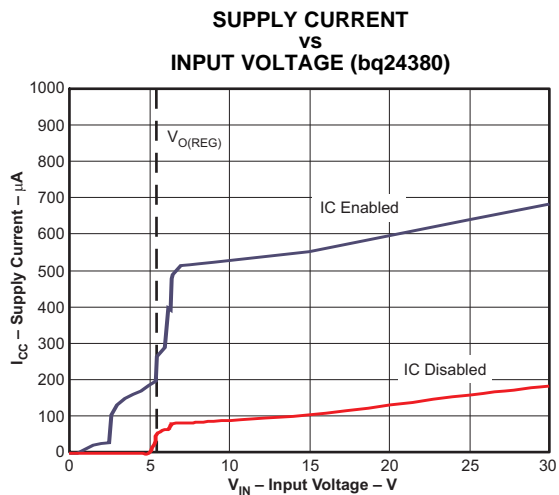

Figure 15.

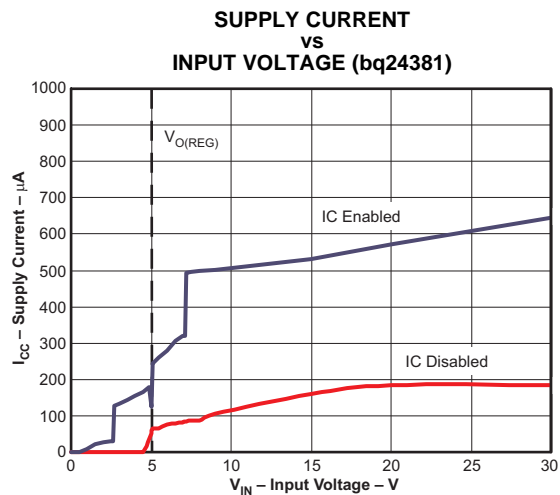

Figure 16.

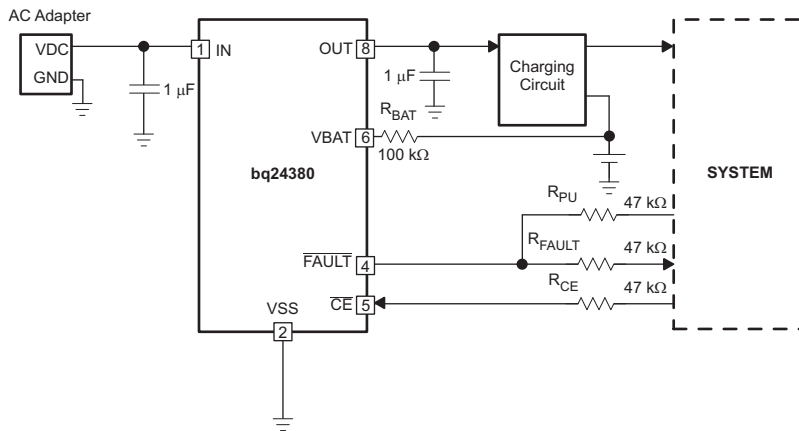
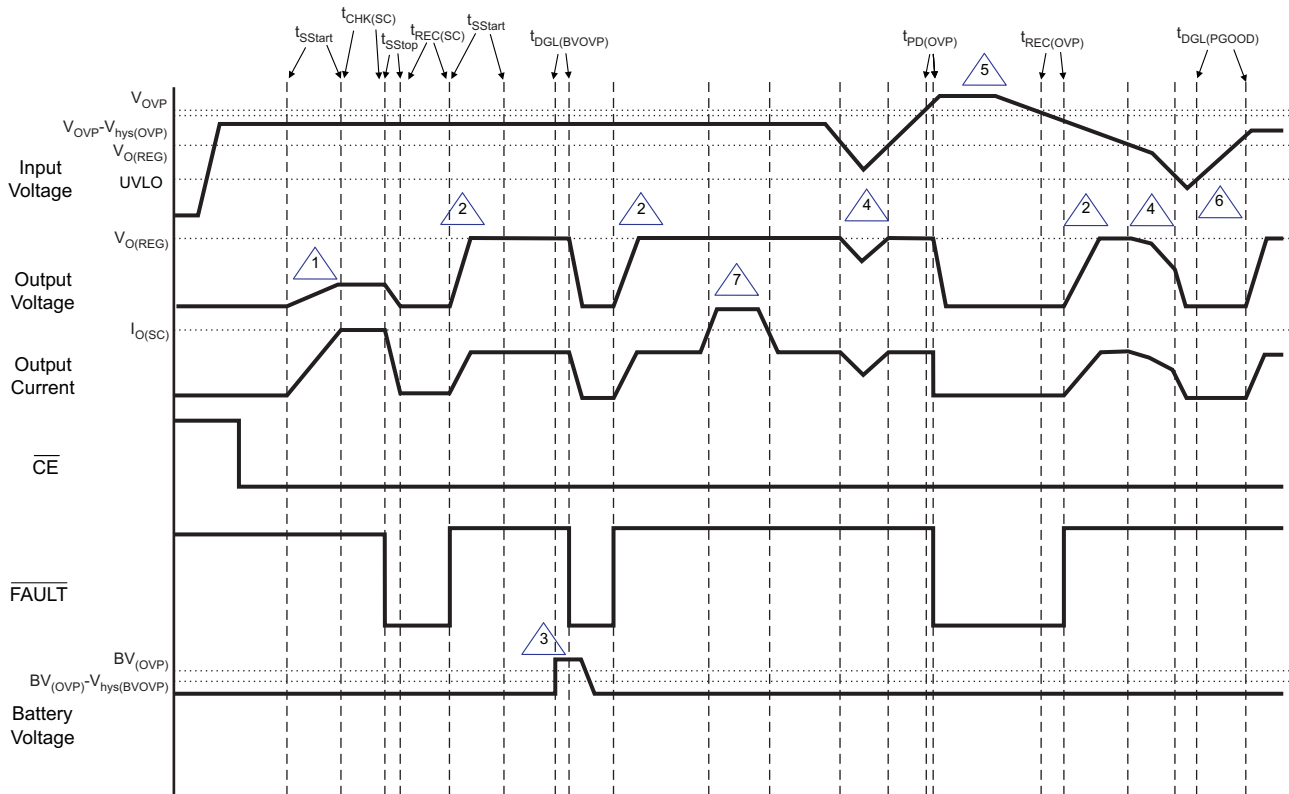

Figure 17. Typical Application Circuit



1. Short-circuit during start-up
2. Normal start-up condition
3. Battery overvoltage event
4. $V_{UVLO} < V_{IN} < V_{OREG}$ -- V_{OUT} tracks V_{IN}
5. Input overvoltage event
6. Input below UVLO
7. High-current event during normal operation

Figure 18. Timing Diagram

DETAILED FUNCTIONAL DESCRIPTION

The bq2438x is a highly integrated circuit designed to provide protection to Li-ion batteries from failures of the charging circuit and the input source. The IC continuously monitors the input voltage and the battery voltage. The device operates like a linear regulator, maintaining a 5.5-V (bq24380) or 5-V (bq24381) output with input voltages up to the input overvoltage threshold (V_{OVP}). If the input voltage exceeds V_{OVP} , the IC shuts off the pass FET and disconnects the system from input power. Additionally, if the battery voltage rises above 4.35 V, the IC switches off the pass FET, removing the power from the system until the battery voltage falls to safe levels. The IC also monitors its die temperature and switches the pass FET off if it exceeds 140°C.

The IC can be controlled by a processor, and also provides status information about fault conditions to the host.

POWER DOWN

The device remains in power-down mode when the input voltage at the IN pin is below the undervoltage threshold (UVLO) of 2.8 V. The FET connected between the IN and OUT pins is off, and the status output, $\overline{\text{FAULT}}$, is set to HI-Z.

POWER ON RESET

The device resets when the input voltage at the IN pin exceeds the UVLO threshold. During power-on reset, the IC waits for duration $t_{DGL(PGOOD)}$ for the input voltage to stabilize. If, after $t_{DGL(PGOOD)}$, the input voltage and battery voltage are within operation limits, the pass FET is turned ON. The IC has a soft-start feature to control the inrush current. The soft-start minimizes the ringing at the input due to the resonant circuit formed by the parasitic inductance of the adapter cable and the input bypass capacitor. During the soft-start time, t_{SStart} , the current limit is stepped up in 8 equal steps every 625 μ s. Each step is 1/8 of the $I_{O(SC)}$. After the soft-start sequence is over, the IC samples the load current. If the load current exceeds $I_{O(SC)}$, the IC initiates short circuit protection. See the [Startup Short-Circuit Protection](#) section for details. If no overcurrent event is measured, the current monitoring circuitry is disabled for normal operation.

In the event a short-circuit is detected at power-on, to prevent the input voltage from spiking up when the pass FET is switched off (due to the inductance of the input cable), The pass FET is turned off by gradually reducing its gate-drive, resulting in a *soft-stop* (t_{SStop}).

DETAILED FUNCTIONAL DESCRIPTION

The device continuously monitors the input voltage and the battery voltage as described in detail below:

Input Overvoltage Protection

The OUT output of the bq2438x operates similar to a linear regulator. While the input voltage is less than $V_{O(REG)}$, and above the UVLO, the output voltage tracks the input voltage (less the drop caused by $R_{DS(on)}$ of the pass FET). When the input voltage is greater than $V_{O(REG)}$ (plus the $R_{DS(on)}$ drop) and less than V_{OVP} , the output voltage is regulated to $V_{O(REG)}$. $V_{O(REG)}$ is 5.5 V for the BQ24380 and 5 V for the BQ24381. If the input voltage is increased above V_{OVP} , the internal pass FET is turned off, removing power from the charging circuitry connected to OUT. The $\overline{\text{FAULT}}$ output is then asserted low. When the input voltage drops below $V_{OVP} - V_{hys(OVP)}$ (but is still above UVLO), the pass FET is turned on after a deglitch time of $t_{REC(OVP)}$. The deglitch time ensures that the input supply has stabilized. The *condition 5* in [Figure 18](#) illustrates an input overvoltage event.

Battery Overvoltage Protection

The battery overvoltage threshold BV_{OVP} is internally set to 4.35 V for the bq2438x. *Condition 3* in [Figure 18](#) illustrates a battery overvoltage event. If the battery voltage exceeds the BV_{OVP} threshold for longer than $t_{DGL(BVovp)}$, the pass FET is turned off (using soft-stop), and $\overline{\text{FAULT}}$ is asserted low. The pass FET is turned on (using the soft-start sequence) once the battery voltage drops to $BV_{OVP} - V_{hys(BVovp)}$.

Thermal Protection

If the junction temperature of the device exceeds $T_{J(OFF)}$, the pass FET is turned off, and the $\overline{\text{FAULT}}$ output is asserted low. The FET is turned on when the junction temperature falls below $T_{J(OFF)} - T_{J(OFF-HYS)}$.

Start-Up Short-Circuit Protection

The bq2438x features overload current protection during start-up. The *condition 1* in [Figure 18](#) illustrates start-up into an overload condition. If after the eight soft-start steps are complete, and the current limit is exceeded, the IC initiates a short-circuit check timer ($t_{CHK(SC)}$). During this check, the current is clamped to $I_{O(SC)}$. If the 5-ms $t_{CHK(SC)}$ timer expires and the current remains clamped by the current limit, the internal pass FET is turned off using the soft-stop method, \overline{FAULT} is pulled low and the $t_{REC(SC)}$ timer begins. Once the $t_{REC(SC)}$ timer expires, \overline{FAULT} becomes high impedance and the soft-start sequence restarts. The device repeats the start/fail sequence until the overload condition is removed. Once the overload condition is removed, the current limit circuitry is disabled and the device enters normal operation. Additionally, if the current is not limited after the completion of the soft-start sequence, the $t_{CHK(SC)}$ timer does not start and the current limit circuitry is disabled for normal operation.

Enable Function

The IC has an enable pin which is used to enable and disable the device. Connect the \overline{CE} pin high to turn off the internal pass FET. Connect the \overline{CE} pin low to turn on the internal pass FET and enter the start-up routine. The \overline{CE} pin has an internal pulldown resistor and can be left unconnected. The \overline{FAULT} pin is high impedance when the \overline{CE} pin is high.

Fault Indication

The \overline{FAULT} pin is an active-low, open-drain output. It is in a high-impedance state when operating conditions are safe, or when the device is disabled by setting \overline{CE} high. With \overline{CE} low, the \overline{FAULT} pin goes low whenever any of these events occurs:

1. Output short-circuit at power-on
2. Input overvoltage
3. Battery overvoltage
4. IC overtemperature

See [Figure 18](#) for an example of \overline{FAULT} conditions during these events. Connect the \overline{FAULT} pin to the desired logic level voltage rail through a resistor between 1 k Ω and 50 k Ω .

APPLICATION INFORMATION

Selection of $R_{(BAT)}$

It is recommended that the battery not be tied directly to the VBAT pin of the device, as under some failure modes of the IC, the voltage at the IN pin may appear on the VBAT pin. This voltage can be as high as 30 V, and applying 30 V to the battery may cause failure of the device and can be hazardous. Connecting the VBAT pin through $R_{(BAT)}$ prevents a large current from flowing into the battery in the event of failure. For safety, $R_{(BAT)}$ must have a high value. The problem with a large $R_{(BAT)}$ is that the voltage drops across the resistor because of the VBAT bias current, $I_{(VBAT)}$, which causes an error in the BV_{OVP} threshold. This error is over and above the tolerance on the nominal 4.35-V BV_{OVP} threshold.

Choosing $R_{(BAT)}$ in the range of 100 k Ω to 470 k Ω is a good compromise. If the IC fails with $R_{(BAT)}$ equal to 100 k Ω , the maximum current flowing into the battery would be $(30\text{ V} - 3\text{ V}) \div 100\text{ k}\Omega = 246\text{ }\mu\text{A}$, which is low enough to be absorbed by the bias currents of the system components. $R_{(BAT)}$ equal to 100 k Ω results in a worst-case voltage drop of $R_{(BAT)} \times I_{(VBAT)} \approx 1\text{ mV}$. This is negligible compared to the internal tolerance of 50 mV on the BV_{OVP} threshold.

If the Bat-OVP function is not required, the VBAT pin must be connected to VSS.

Selection of $R_{(CE)}$

The \overline{CE} pin can be used to enable and disable the IC. If host control is not required, the \overline{CE} pin can be tied to ground or left unconnected, permanently enabling the device.

In applications where external control is required, the \overline{CE} pin can be controlled by a host processor. As with the VBAT pin (see previous discussion), the \overline{CE} pin must be connected to the host GPIO pin through as large a resistor as possible. The limitation on the resistor value is that the minimum V_{OH} of the host GPIO pin less the drop across the resistor must be greater than V_{IH} of the bq2430x \overline{CE} pin. The drop across the resistor is given by $R_{(CE)} \times I_{IH}$.

Selection of Input and Output Bypass Capacitors

The input capacitor C_{IN} in [Figure 17](#) is for decoupling and serves an important purpose. Whenever a step change downwards in the system load current occurs, the inductance of the input cable causes the input voltage to spike up. C_{IN} prevents the input voltage from overshooting to dangerous levels. It is recommended that a ceramic capacitor of at least 1 μF be used at the input of the device. It must be located in close proximity to the IN pin.

C_{OUT} in [Figure 17](#) is also important. During an overvoltage transient, this capacitance limits the output overshoot until the power FET is turned off by the overvoltage protection circuitry. C_{OUT} must be a ceramic capacitor of at least 1 μF , located close to the OUT pin. C_{OUT} also serves as the input decoupling capacitor for the charging circuit downstream of the protection IC.

PCB Layout Guidelines

1. This device is a protection device and is meant to protect down-stream circuitry from hazardous voltages. Potentially, high voltages may be applied to this IC. It has to be ensured that the edge-to-edge clearances of PCB traces satisfy the design rules for the maximum voltages expected to be seen in the system.
2. The device uses SON packages with a PowerPAD™. For good thermal performance, the PowerPAD must be thermally coupled with the PCB ground plane. In most applications, this requires a copper pad directly under the IC. This copper pad should be connected to the ground plane with an array of thermal vias.
3. C_{IN} and C_{OUT} should be located close to the IC. Other components like $R_{(BAT)}$ should also be located close to the IC.

PACKAGING INFORMATION

Orderable Device	Status ⁽¹⁾	Package Type	Package Drawing	Pins	Package Qty	Eco Plan ⁽²⁾	Lead/Ball Finish	MSL Peak Temp ⁽³⁾
BQ24380DSGR	ACTIVE	SON	DSG	8	3000	Green (RoHS & no Sb/Br)	CU NIPDAU	Level-2-260C-1 YEAR
BQ24380DSGT	ACTIVE	SON	DSG	8	250	Green (RoHS & no Sb/Br)	CU NIPDAU	Level-2-260C-1 YEAR
BQ24381DSGR	ACTIVE	SON	DSG	8	3000	Green (RoHS & no Sb/Br)	CU NIPDAU	Level-2-260C-1 YEAR
BQ24381DSGT	ACTIVE	SON	DSG	8	250	Green (RoHS & no Sb/Br)	CU NIPDAU	Level-2-260C-1 YEAR

⁽¹⁾ The marketing status values are defined as follows:

ACTIVE: Product device recommended for new designs.

LIFEBUY: TI has announced that the device will be discontinued, and a lifetime-buy period is in effect.

NRND: Not recommended for new designs. Device is in production to support existing customers, but TI does not recommend using this part in a new design.

PREVIEW: Device has been announced but is not in production. Samples may or may not be available.

OBSOLETE: TI has discontinued the production of the device.

⁽²⁾ Eco Plan - The planned eco-friendly classification: Pb-Free (RoHS), Pb-Free (RoHS Exempt), or Green (RoHS & no Sb/Br) - please check <http://www.ti.com/productcontent> for the latest availability information and additional product content details.

TBD: The Pb-Free/Green conversion plan has not been defined.

Pb-Free (RoHS): TI's terms "Lead-Free" or "Pb-Free" mean semiconductor products that are compatible with the current RoHS requirements for all 6 substances, including the requirement that lead not exceed 0.1% by weight in homogeneous materials. Where designed to be soldered at high temperatures, TI Pb-Free products are suitable for use in specified lead-free processes.

Pb-Free (RoHS Exempt): This component has a RoHS exemption for either 1) lead-based flip-chip solder bumps used between the die and package, or 2) lead-based die adhesive used between the die and leadframe. The component is otherwise considered Pb-Free (RoHS compatible) as defined above.

Green (RoHS & no Sb/Br): TI defines "Green" to mean Pb-Free (RoHS compatible), and free of Bromine (Br) and Antimony (Sb) based flame retardants (Br or Sb do not exceed 0.1% by weight in homogeneous material)

⁽³⁾ MSL, Peak Temp. -- The Moisture Sensitivity Level rating according to the JEDEC industry standard classifications, and peak solder temperature.

Important Information and Disclaimer:The information provided on this page represents TI's knowledge and belief as of the date that it is provided. TI bases its knowledge and belief on information provided by third parties, and makes no representation or warranty as to the accuracy of such information. Efforts are underway to better integrate information from third parties. TI has taken and continues to take reasonable steps to provide representative and accurate information but may not have conducted destructive testing or chemical analysis on incoming materials and chemicals. TI and TI suppliers consider certain information to be proprietary, and thus CAS numbers and other limited information may not be available for release.

In no event shall TI's liability arising out of such information exceed the total purchase price of the TI part(s) at issue in this document sold by TI to Customer on an annual basis.

TAPE AND REEL INFORMATION

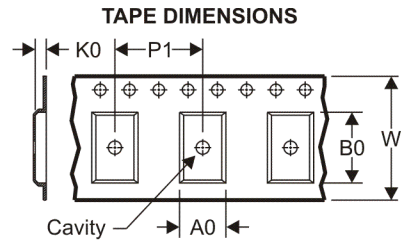
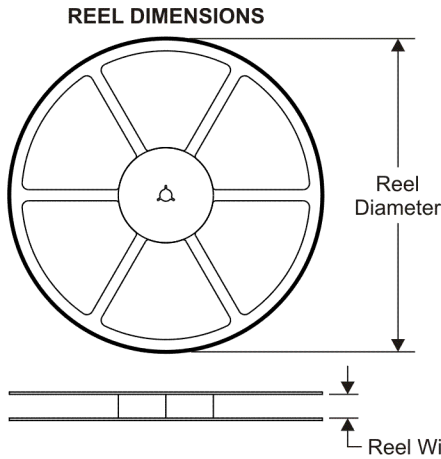

A0	Dimension designed to accommodate the component width
B0	Dimension designed to accommodate the component length
K0	Dimension designed to accommodate the component thickness
W	Overall width of the carrier tape
P1	Pitch between successive cavity centers

QUADRANT ASSIGNMENTS FOR PIN 1 ORIENTATION IN TAPE

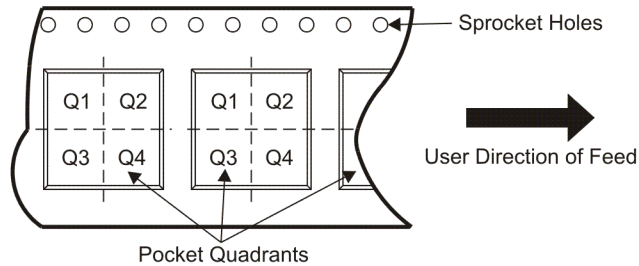

*All dimensions are nominal

Device	Package Type	Package Drawing	Pins	SPQ	Reel Diameter (mm)	Reel Width W1 (mm)	A0 (mm)	B0 (mm)	K0 (mm)	P1 (mm)	W (mm)	Pin1 Quadrant
BQ24380DSGR	SON	DSG	8	3000	179.0	8.4	2.2	2.2	1.2	4.0	8.0	Q2
BQ24380DSGT	SON	DSG	8	250	179.0	8.4	2.2	2.2	1.2	4.0	8.0	Q2
BQ24381DSGR	SON	DSG	8	3000	179.0	8.4	2.2	2.2	1.2	4.0	8.0	Q2
BQ24381DSGT	SON	DSG	8	250	179.0	8.4	2.2	2.2	1.2	4.0	8.0	Q2

TAPE AND REEL BOX DIMENSIONS



*All dimensions are nominal

Device	Package Type	Package Drawing	Pins	SPQ	Length (mm)	Width (mm)	Height (mm)
BQ24380DSGR	SON	DSG	8	3000	195.0	200.0	45.0
BQ24380DSGT	SON	DSG	8	250	195.0	200.0	45.0
BQ24381DSGR	SON	DSG	8	3000	195.0	200.0	45.0
BQ24381DSGT	SON	DSG	8	250	195.0	200.0	45.0

[查询"BQ24380"供应商](#)

DSG (S-PDSO-N8)

PLASTIC SMALL OUTLINE

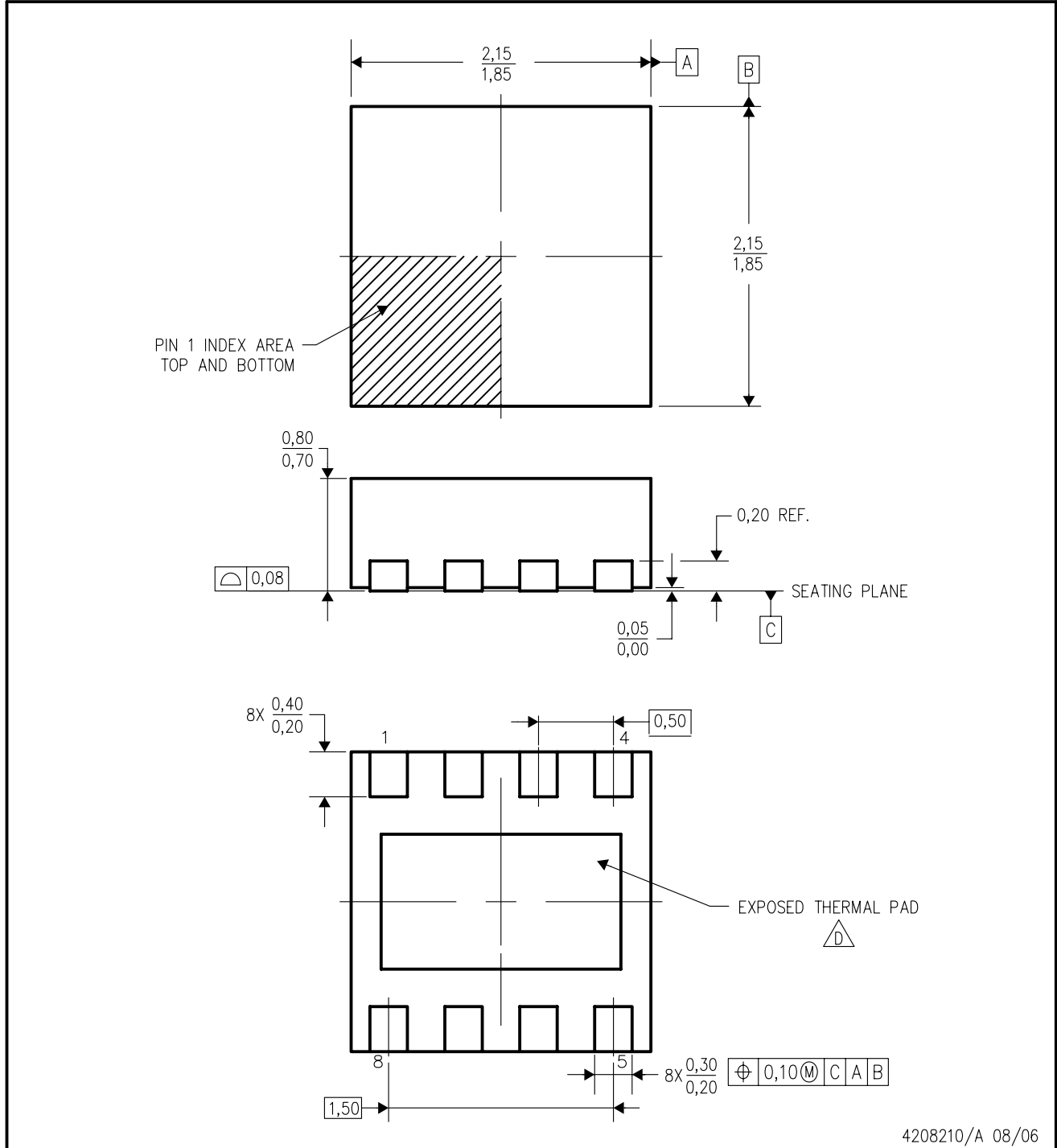

- NOTES:
- A. All linear dimensions are in millimeters. Dimensioning and tolerancing per ASME Y14.5M-1994.
 - B. This drawing is subject to change without notice.
 - C. Quad Flatpack, No-Leads (QFN) package configuration.
 - D. The package thermal pad must be soldered to the board for thermal and mechanical performance. See the Product Data Sheet for details regarding the exposed thermal pad dimensions.
 - E. Falls within JEDEC MO-229.

THERMAL INFORMATION

This package incorporates an exposed thermal pad that is designed to be attached directly to an external heatsink. The thermal pad must be soldered directly to the printed circuit board (PCB). After soldering, the PCB can be used as a heatsink. In addition, through the use of thermal vias, the thermal pad can be attached directly to the appropriate copper plane shown in the electrical schematic for the device, or alternatively, can be attached to a special heatsink structure designed into the PCB. This design optimizes the heat transfer from the integrated circuit (IC).

For information on the Quad Flatpack No-Lead (QFN) package and its advantages, refer to Application Report, Quad Flatpack No-Lead Logic Packages, Texas Instruments Literature No. SCBA017. This document is available at www.ti.com.

The exposed thermal pad dimensions for this package are shown in the following illustration.

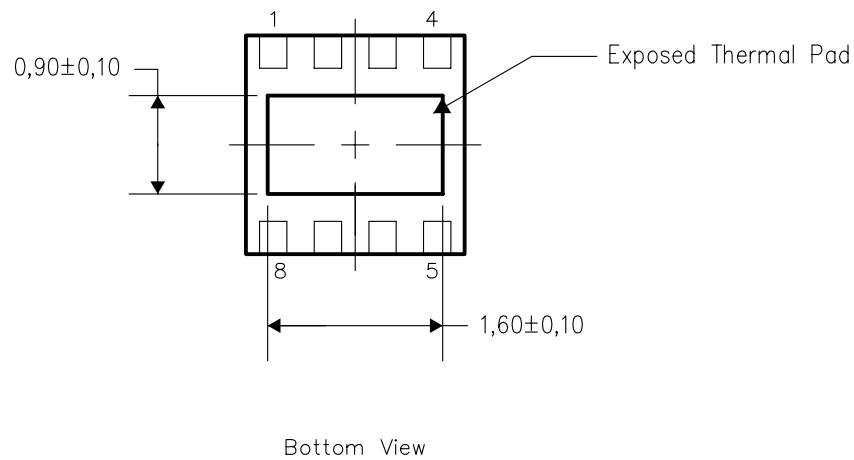

NOTE: All linear dimensions are in millimeters

Exposed Thermal Pad Dimensions

[查询"BQ24380"供应商](#)

DSG (S-PDSO-N8) – Minimized Design

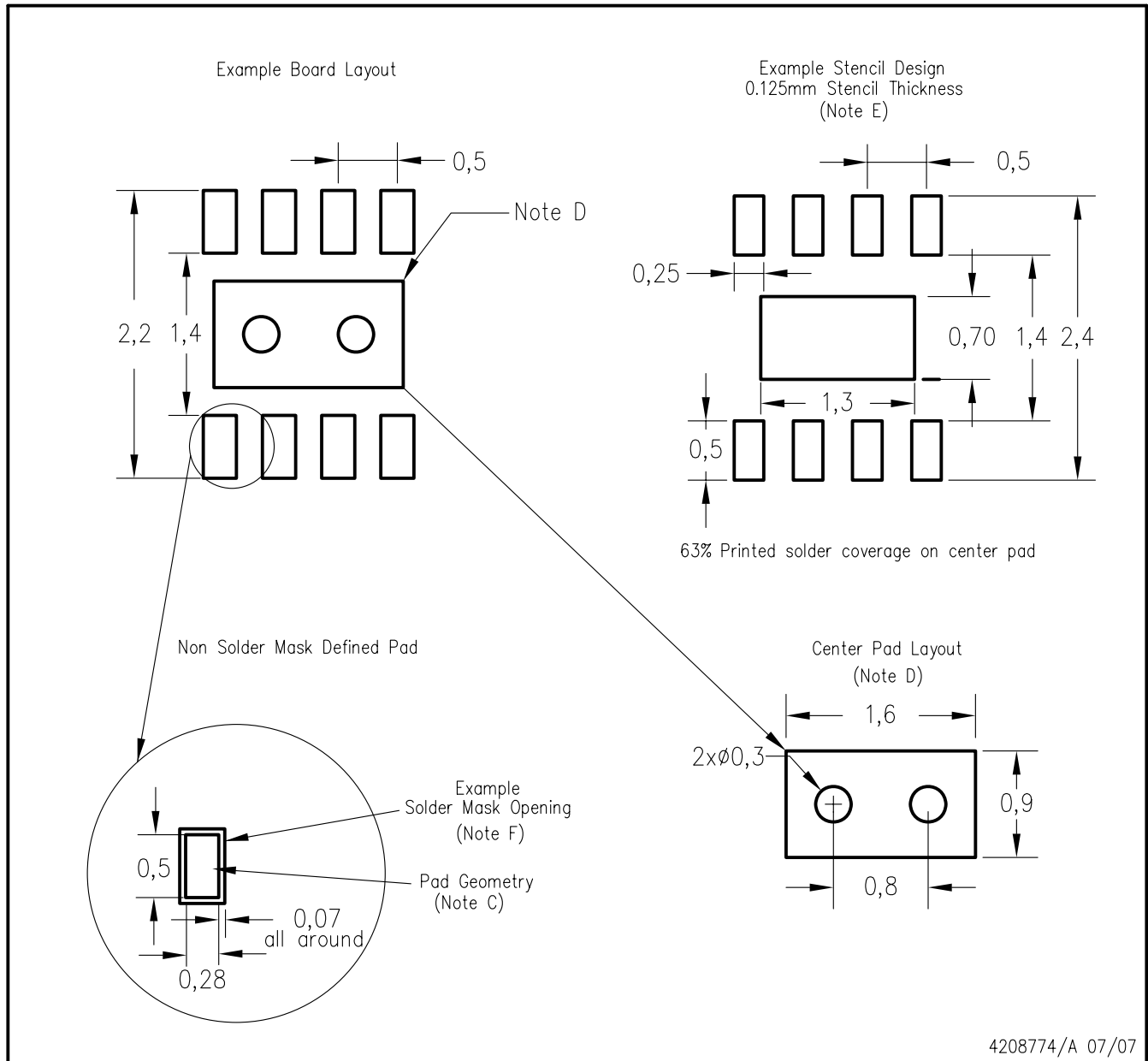

- NOTES:
- A. All linear dimensions are in millimeters.
 - B. This drawing is subject to change without notice.
 - C. Publication IPC-7351 is recommended for alternate designs.
 - D. This package is designed to be soldered to a thermal pad on the board. Refer to Application Note, QFN Packages, Texas Instruments Literature No. SCBA017, SLUA271, and also the Product Data Sheets for specific thermal information, via requirements, and recommended board layout. These documents are available at www.ti.com <<http://www.ti.com>>.
 - E. Laser cutting apertures with trapezoidal walls and also rounding corners will offer better paste release. Customers should contact their board assembly site for stencil design recommendations. Refer to IPC 7525 for stencil design considerations.
 - F. Customers should contact their board fabrication site for solder mask tolerances.

IMPORTANT NOTICE

Texas Instruments Incorporated and its subsidiaries (TI) reserve the right to make corrections, modifications, enhancements, improvements, and other changes to its products and services at any time and to discontinue any product or service without notice. Customers should obtain the latest relevant information before placing orders and should verify that such information is current and complete. All products are sold subject to TI's terms and conditions of sale supplied at the time of order acknowledgment.

TI warrants performance of its hardware products to the specifications applicable at the time of sale in accordance with TI's standard warranty. Testing and other quality control techniques are used to the extent TI deems necessary to support this warranty. Except where mandated by government requirements, testing of all parameters of each product is not necessarily performed.

TI assumes no liability for applications assistance or customer product design. Customers are responsible for their products and applications using TI components. To minimize the risks associated with customer products and applications, customers should provide adequate design and operating safeguards.

TI does not warrant or represent that any license, either express or implied, is granted under any TI patent right, copyright, mask work right, or other TI intellectual property right relating to any combination, machine, or process in which TI products or services are used. Information published by TI regarding third-party products or services does not constitute a license from TI to use such products or services or a warranty or endorsement thereof. Use of such information may require a license from a third party under the patents or other intellectual property of the third party, or a license from TI under the patents or other intellectual property of TI.

Reproduction of TI information in TI data books or data sheets is permissible only if reproduction is without alteration and is accompanied by all associated warranties, conditions, limitations, and notices. Reproduction of this information with alteration is an unfair and deceptive business practice. TI is not responsible or liable for such altered documentation. Information of third parties may be subject to additional restrictions.

Resale of TI products or services with statements different from or beyond the parameters stated by TI for that product or service voids all express and any implied warranties for the associated TI product or service and is an unfair and deceptive business practice. TI is not responsible or liable for any such statements.

TI products are not authorized for use in safety-critical applications (such as life support) where a failure of the TI product would reasonably be expected to cause severe personal injury or death, unless officers of the parties have executed an agreement specifically governing such use. Buyers represent that they have all necessary expertise in the safety and regulatory ramifications of their applications, and acknowledge and agree that they are solely responsible for all legal, regulatory and safety-related requirements concerning their products and any use of TI products in such safety-critical applications, notwithstanding any applications-related information or support that may be provided by TI. Further, Buyers must fully indemnify TI and its representatives against any damages arising out of the use of TI products in such safety-critical applications.

TI products are neither designed nor intended for use in military/aerospace applications or environments unless the TI products are specifically designated by TI as military-grade or "enhanced plastic." Only products designated by TI as military-grade meet military specifications. Buyers acknowledge and agree that any such use of TI products which TI has not designated as military-grade is solely at the Buyer's risk, and that they are solely responsible for compliance with all legal and regulatory requirements in connection with such use.

TI products are neither designed nor intended for use in automotive applications or environments unless the specific TI products are designated by TI as compliant with ISO/TS 16949 requirements. Buyers acknowledge and agree that, if they use any non-designated products in automotive applications, TI will not be responsible for any failure to meet such requirements.

Following are URLs where you can obtain information on other Texas Instruments products and application solutions:

Products

Amplifiers	amplifier.ti.com
Data Converters	dataconverter.ti.com
DSP	dsp.ti.com
Clocks and Timers	www.ti.com/clocks
Interface	interface.ti.com
Logic	logic.ti.com
Power Mgmt	power.ti.com
Microcontrollers	microcontroller.ti.com
RFID	www.ti-rfid.com
RF/IF and ZigBee® Solutions	www.ti.com/lprf

Applications

Audio	www.ti.com/audio
Automotive	www.ti.com/automotive
Broadband	www.ti.com/broadband
Digital Control	www.ti.com/digitalcontrol
Medical	www.ti.com/medical
Military	www.ti.com/military
Optical Networking	www.ti.com/opticalnetwork
Security	www.ti.com/security
Telephony	www.ti.com/telephony
Video & Imaging	www.ti.com/video
Wireless	www.ti.com/wireless