

"C" Option

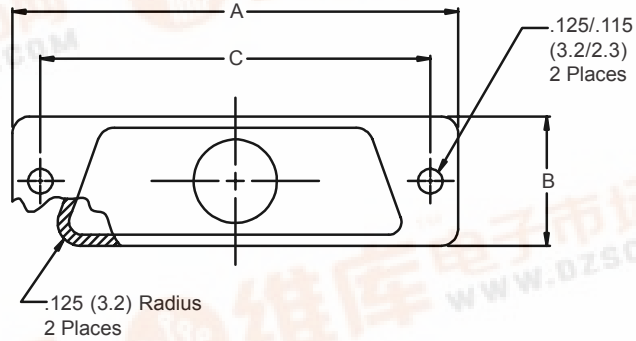

**NOTES:**

1. Metric dimensions (mm) are indicated in parentheses.
2. End Fitting may be brazed on per MIL-B-7883B, Type V, Grade B.

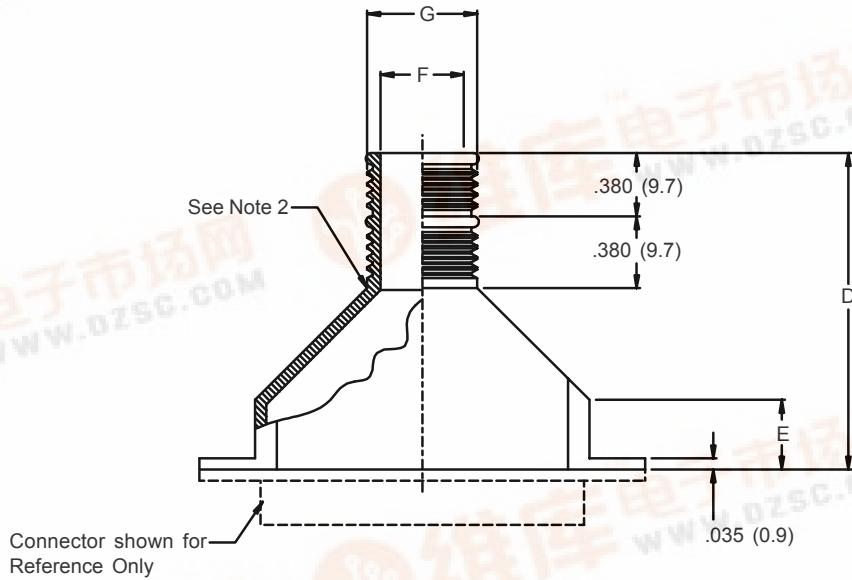



**TABLE I: BACKSHELL & CONNECTOR INTERFACE DIMENSIONS**

Shell Size	A	B	C ±.005 (0.1)	D	E	Max Entry Size
1	1.203 (30.6)	.500 (12.7)	.984 (25.0)	1.570 (39.9)	.440 (11.2)	06
2	1.531 (38.9)	.500 (12.7)	1.312 (33.3)	1.650 (41.9)	.440 (11.2)	06
3	2.078 (52.8)	.500 (12.7)	1.852 (47.0)	1.930 (49.0)	.500 (12.7)	06
4	2.718 (69.0)	.500 (12.7)	2.500 (63.5)	2.070 (52.6)	.500 (12.7)	06
5	2.625 (66.7)	.609 (15.5)	2.406 (61.1)	2.050 (52.1)	.440 (11.2)	08

**TABLE II: CABLE ENTRY**

Entry Size	F	G
01	.125 (3.2)	.205 (5.2)
02	.187 (4.7)	.267 (6.8)
03	.265 (6.7)	.360 (9.1)
04	.312 (7.9)	.392 (10.0)
05	.390 (9.9)	.485 (12.3)
06	.415 (10.5)	.510 (13.0)
07	.500 (12.7)	.580 (14.7)
08	.525 (13.3)	.620 (15.7)

**TABLE III:  
FINISH OPTIONS**

Symbol	Finish
B	Cadmium Plate/Olive Drab
C*	Black Anodize
G*	Anodic Hard Coat
J	Gold Iridite over Cadmium Plate over Electroless Nickel
LF	Cadmium Plate/Bright over Electroless Nickel
M	Electroless Nickel
N	Cadmium Plate/Olive Drab over Electroless Nickel
NC	Zinc Cobalt/Dark Olive Drab
NF	Cadmium Plate/Olive Drab over Electroless Nickel
T	Cadmium Plate/Bright over Electroless Nickel
U**	Cadmium Plate/Black
ZN	Zinc-Nickel Alloy/Olive Drab

\*Anodize finish is not suitable for EMI shielding or grounding applications.  
\*\*Applicable to corrosion resisting steel backshells and accessories. Consult factory for other available finishes.

Metric dimensions (mm) are indicated in parentheses