

[查询"2SK1508"供应商](#)

> **Features**

- High Current
- Low On-Resistance
- No Secondary Breakdown
- Low Driving Power
- High Forward Transconductance

> **Applications**

- Motor Control
- General Purpose Power Amplifier
- DC-DC converters

> **Outline Drawing**

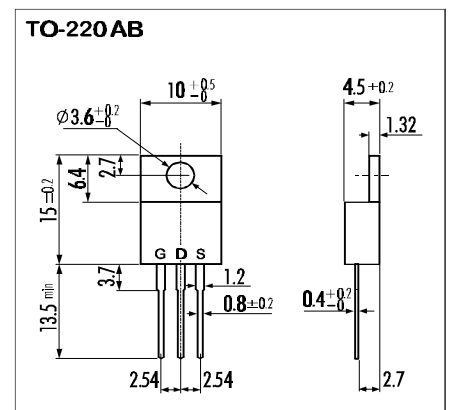

> **Maximum Ratings and Characteristics**

- Absolute Maximum Ratings ( $T_C=25^\circ\text{C}$ ), unless otherwise specified

Item	Symbol	Rating	Unit
Drain-Source-Voltage	$V_{DS}$	60	V
Continuous Drain Current	$I_D$	35	A
Pulsed Drain Current	$I_{D(puls)}$	140	A
Continuous Reverse Drain Current	$I_{DR}$	35	A
Gate-Source-Voltage	$V_{GS}$	±20	V
Max. Power Dissipation	$P_D$	60	W
Operating and Storage Temperature Range	$T_{ch}$	150	$^\circ\text{C}$
	$T_{stg}$	-55 ~ +150	$^\circ\text{C}$

> **Equivalent Circuit**

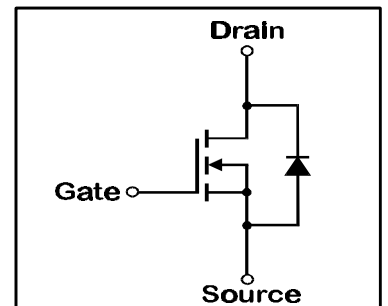

- Electrical Characteristics ( $T_C=25^\circ\text{C}$ ), unless otherwise specified

Item	Symbol	Test conditions	Min.	Typ.	Max.	Unit
Drain-Source Breakdown-Voltage	$V_{(BR)DSS}$	$I_D=1\text{mA}$ $V_{GS}=0\text{V}$	60			V
Gate Threshold Voltage	$V_{GS(th)}$	$I_D=1\text{mA}$ $V_{DS}=V_{GS}$	1,0	1,5	2,5	V
Zero Gate Voltage Drain Current	$I_{DSS}$	$V_{DS}=60\text{V}$ $T_{ch}=25^\circ\text{C}$		10	500	$\mu\text{A}$
		$V_{GS}=0\text{V}$ $T_{ch}=125^\circ\text{C}$		0,2	1,0	mA
Gate Source Leakage Current	$I_{GSS}$	$V_{GS}=\pm 20\text{V}$ $V_{DS}=0\text{V}$		10	100	$\mu\text{A}$
Drain Source On-State Resistance	$R_{DS(on)}$	$I_D=17,5\text{A}$ $V_{GS}=4\text{V}$		0,037	0,056	$\Omega$
		$I_D=17,5\text{A}$ $V_{GS}=10\text{V}$		0,025	0,035	$\Omega$
Forward Transconductance	$g_{fs}$	$I_D=17,5\text{A}$ $V_{DS}=25\text{V}$	10	18		S
Input Capacitance	$C_{iss}$	$V_{DS}=25\text{V}$		1800	2700	pF
Output Capacitance	$C_{oss}$	$V_{GS}=0\text{V}$		620	930	pF
Reverse Transfer Capacitance	$C_{rss}$	$f=1\text{MHz}$		240	360	pF
Turn-On-Time $t_{on}$ ( $t_{on}=t_{d(on)}+t_r$ )	$t_{d(on)}$	$V_{CC}=30\text{V}$		6	9	ns
	$t_r$	$I_D=10\text{A}$		60	90	ns
Turn-Off-Time $t_{off}$ ( $t_{off}=t_{d(off)}+t_f$ )	$t_{d(off)}$	$V_{GS}=35\text{V}$		350	530	ns
	$t_f$	$R_{GS}=25\ \Omega$		150	230	ns
Diode Forward On-Voltage	$V_{SD}$	$I_F=2I_{DR}$ $V_{GS}=0\text{V}$ $T_{ch}=25^\circ\text{C}$		1,35	2,0	V
Reverse Recovery Time	$t_{rr}$	$I_F=I_{DR}$ $V_{GS}=0\text{V}$ $-di_F/dt=100\text{A}/\mu\text{s}$ $T_{ch}=25^\circ\text{C}$		60		ns

- Thermal Characteristics

Item	Symbol	Test conditions	Min.	Typ.	Max.	Unit
Thermal Resistance	$R_{th(ch-a)}$	channel to air			75	$^\circ\text{C}/\text{W}$
	$R_{th(ch-c)}$	channel to case			2,08	$^\circ\text{C}/\text{W}$

