

2-input AND gate

74HC1G08;
74HCT1G08

FEATURES

- Wide operating voltage: 2.0 to 6.0 V
- Symmetrical output impedance
- High noise immunity
- Low power dissipation
- Balanced propagation delays
- Very small 5 pins package
- Output capability: standard.

DESCRIPTION

The 74HC1G/HCT1G08 is a high-speed Si-gate CMOS device.

The 74HC1G/HCT1G08 provides the 2-input AND function. The standard output currents are 1/2 compared to the 74HC/HCT08.

FUNCTION TABLE

See note 1.

INPUTS		OUTPUT
inA	inB	outY
L	L	L
L	H	L
H	L	L
H	H	H

Note

1. H = HIGH voltage level;
L = LOW voltage level.

QUICK REFERENCE DATA

GND = 0 V; T_{amb} = 25 °C; t_r = t_f ≤ 6.0 ns.

SYMBOL	PARAMETER	CONDITIONS	TYP.		UNIT
			HC1G	HCT1G	
t _{PHL} /t _{PLH}	propagation delay inA, inB to outY	C _L = 15 pF; V _{CC} = 5 V	7	11	ns
C _I	input capacitance		1.5	1.5	pF
C _{PD}	power dissipation capacitance	notes 1 and 2	19	21	pF

Notes

1. C_{PD} is used to determine the dynamic power dissipation (P_D in μW).
 $P_D = C_{PD} \times V_{CC}^2 \times f_i + \sum (C_L \times V_{CC}^2 \times f_o)$ where:
 f_i = input frequency in MHz;
 f_o = output frequency in MHz;
 C_L = output load capacitance in pF;
 V_{CC} = supply voltage in V;
 $\sum (C_L \times V_{CC}^2 \times f_o)$ = sum of outputs.
2. For HC1G the condition is V_I = GND to V_{CC}.
 For HCT1G the condition is V_I = GND to V_{CC} - 1.5 V.

PINNING

PIN	SYMBOL	DESCRIPTION
1	inB	data input B
2	inA	data input A
3	GND	ground (0 V)
4	outY	data output
5	V _{CC}	DC supply voltage

2-input AND gate

74HC1G08;
74HCT1G08

ORDERING AND PACKAGE INFORMATION

OUTSIDE NORTH AMERICA	PACKAGES					
	TEMPERATURE RANGE	PINS	PACKAGE	MATERIAL	CODE	MARKING
74HC1G08GW	-40 to +125 °C	5	SC-88A	plastic	SOT353	HE
74HCT1G08GW		5	SC-88A	plastic	SOT353	TE

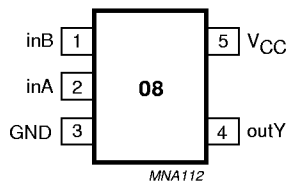

Fig.1 Pin configuration.

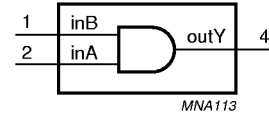

Fig.2 Logic symbol.



Fig.3 IEC logic symbol.

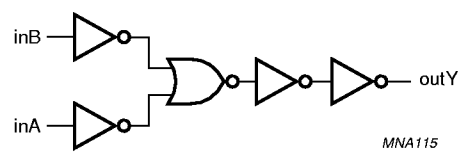

Fig.4 Logic diagram.

2-input AND gate

74HC1G08;
74HCT1G08

RECOMMENDED OPERATING CONDITIONS

SYMBOL	PARAMETER	74HC1G04			74HCT1G04			UNIT	CONDITIONS
		MIN.	TYP.	MAX.	MIN.	TYP.	MAX.		
V _{CC}	DC supply voltage	2.0	5.0	6.0	4.5	5.0	5.5	V	
V _I	input voltage	0	–	V _{CC}	0	–	V _{CC}	V	
V _O	output voltage	0	–	V _{CC}	0	–	V _{CC}	V	
T _{amb}	operating ambient temperature	–40	+25	+125	–40	+25	+125	°C	see DC and AC characteristics per device
t _r , t _f	input rise and fall times except for Schmitt trigger inputs	–	–	1000	–	–	–	ns	V _{CC} = 2.0 V
		–	–	500	–	–	500	ns	V _{CC} = 4.5 V
		–	–	400	–	–	–	ns	V _{CC} = 6.0 V

LIMITING VALUES

In accordance with the Absolute Maximum Rating System (IEC 134); voltages are referenced to GND (ground = 0 V).

SYMBOL	PARAMETER	CONDITIONS	MIN.	MAX.	UNIT
V _{CC}	DC supply voltage		–0.5	+7.0	V
±I _{IK}	DC input diode current	V _I < –0.5 V or V _I > V _{CC} + 0.5 V; note 1	–	20	mA
±I _{OK}	DC output diode current	V _O < –0.5 V or V _O > V _{CC} + 0.5 V; note 1	–	20	mA
±I _O	DC output source or sink current standard outputs	–0.5 V < V _O < V _{CC} + 0.5 V; note 1	–	12.5	mA
±I _{CC}	DC V _{CC} or GND current for types with standard outputs	note 1	–	25	mA
T _{stg}	storage temperature		–65	+150	°C
P _D	power dissipation per package	temperature range: –40 to +125 °C; note 2	–	200	mW

Notes

1. The input and output voltage ratings may be exceeded if the input and output current ratings are observed.
2. Above 55 °C the value of P_D derates linearly with 2.5 mW/K.

2-input AND gate

74HC1G08;
74HCT1G08

DC CHARACTERISTICS

Family 74HC1G

Additional type data to the recommended operating conditions; voltages are referenced to GND (ground = 0 V).

SYMBOL	PARAMETER	T _{amb} (°C)					UNIT	TEST CONDITIONS	
		-40 to +85			-40 to +125			V _{CC} (V)	OTHER
		MIN.	TYP. ⁽¹⁾	MAX.	MIN.	MAX.			
V _{IH}	HIGH-level input voltage	1.5	1.2	–	1.5	–	V	2.0	
		3.15	2.4	–	3.15	–		4.5	
		4.2	3.2	–	4.2	–		6.0	
V _{IL}	LOW-level input voltage	–	0.8	0.5	–	0.5	V	2.0	
		–	2.1	1.35	–	1.35		4.5	
		–	2.8	1.8	–	1.8		6.0	
V _{OH}	HIGH-level output voltage; all outputs	1.9	2.0	–	1.9	–	V	2.0	V _I = V _{IH} or V _{IL} ; –I _O = 20 μA
		4.4	4.5	–	4.4	–		4.5	
		5.9	6.0	–	5.9	–		6.0	
V _{OH}	HIGH-level output voltage; standard outputs	4.13	4.32	–	3.7	–	V	4.5	V _I = V _{IH} or V _{IL} ; –I _O = 2.0 mA
		5.63	5.81	–	5.2	–		6.0	V _I = V _{IH} or V _{IL} ; –I _O = 2.6 mA
V _{OL}	LOW-level output voltage; all outputs	–	0	0.1	–	0.1	V	2.0	V _I = V _{IH} or V _{IL} ; I _O = 20 μA
		–	0	0.1	–	0.1		4.5	
		–	0	0.1	–	0.1		6.0	
V _{OL}	LOW-level output voltage; standard outputs	–	0.15	0.33	–	0.4	V	4.5	V _I = V _{IH} or V _{IL} ; I _O = 2.0 mA
		–	0.16	0.33	–	0.4		6.0	V _I = V _{IH} or V _{IL} ; I _O = 2.6 mA
I _I	input leakage current	–	–	1.0	–	1.0	μA	6.0	V _I = V _{CC} or GND
I _{CC}	quiescent supply current	–	–	10	–	20	μA	6.0	V _I = V _{CC} or GND; I _O = 0

Note

1. All typical values are measured at T_{amb} = 25 °C.

2-input AND gate

74HC1G08;
74HCT1G08

Family 74HCT1G

Additional type data to the recommended operating conditions; voltages are referenced to GND (ground = 0 V).

SYMBOL	PARAMETER	T _{amb} (°C)					UNIT	TEST CONDITIONS	
		-40 to +85			-40 to +125			V _{CC} (V)	OTHER
		MIN.	TYP. ⁽¹⁾	MAX.	MIN.	MAX.			
V _{IH}	HIGH-level input voltage	2.0	1.6	–	2.0	–	V	4.5 to 5.5	
V _{IL}	LOW-level input voltage	–	1.2	0.8	–	0.8	V	4.5 to 5.5	
V _{OH}	HIGH-level output voltage; all outputs	4.4	4.5	–	4.4	–	V	4.5	V _I = V _{IH} or V _{IL} ; –I _O = 20 μA
V _{OH}	HIGH-level output voltage; standard outputs	4.13	4.32	–	3.7	–	V	4.5	V _I = V _{IH} or V _{IL} ; –I _O = 2.0 mA
V _{OL}	LOW-level output voltage; all outputs	–	0	0.1	–	0.1	V	4.5	V _I = V _{IH} or V _{IL} ; I _O = 20 μA
V _{OL}	LOW-level output voltage; standard outputs	–	0.15	0.33	–	0.4	V	4.5	V _I = V _{IH} or V _{IL} ; I _O = 2.0 mA
I _I	input leakage current	–	–	1.0	–	1.0	μA	5.5	V _I = V _{CC} or GND
I _{CC}	quiescent supply current	–	–	10.0	–	20	μA	5.5	V _I = V _{CC} or GND; I _O = 0
ΔI _{CC}	additional supply current per input	–	–	500	–	850	μA	4.5 to 5.5	V _I = V _{CC} – 2.1; I _O = 0

Note

1. All typical values are measured at T_{amb} = 25 °C.

2-input AND gate

74HC1G08;
74HCT1G08

AC CHARACTERISTICS

Type 74HC1G08

GND = 0 V; $t_r = t_f \leq 6.0$ ns; $C_L = 50$ pF.

SYMBOL	PARAMETER	T_{amb} (°C)					UNIT	TEST CONDITIONS	
		-40 to +85			-40 to +125			V_{CC} (V)	WAVEFORMS
		MIN.	TYP. ⁽¹⁾	MAX.	MIN.	MAX.			
t_{PHL}/t_{PLH}	propagation delay inA, inB to outY	-	25	115	-	135	ns	2.0	see Figs 5 and 6
		-	9	23	-	27	ns	4.5	
		-	8	20	-	23	ns	6.0	

Note

1. All typical values are measured at $T_{amb} = 25$ °C.

Type 74HCT1G08

GND = 0 V; $t_r = t_f \leq 6.0$ ns; $C_L = 50$ pF.

SYMBOL	PARAMETER	T_{amb} (°C)					UNIT	TEST CONDITIONS	
		-40 to +85			-40 to +125			V_{CC} (V)	WAVEFORMS
		MIN.	TYP. ⁽¹⁾	MAX.	MIN.	MAX.			
t_{PHL}/t_{PLH}	propagation delay inA, inB to outY	-	11	23	-	27	ns	4.5	see Figs 5 and 6

Note

1. All typical values are measured at $T_{amb} = 25$ °C.

2-input AND gate

74HC1G08;
74HCT1G08

AC WAVEFORMS

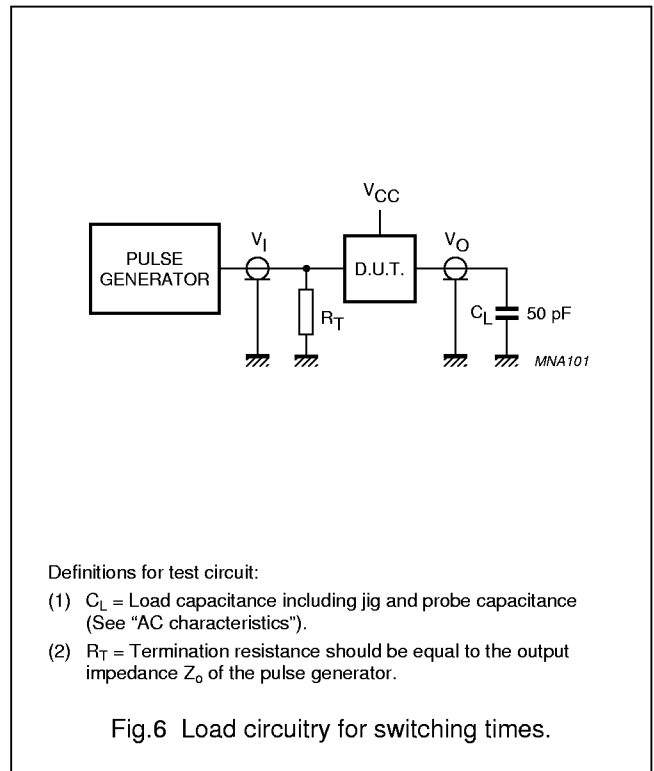
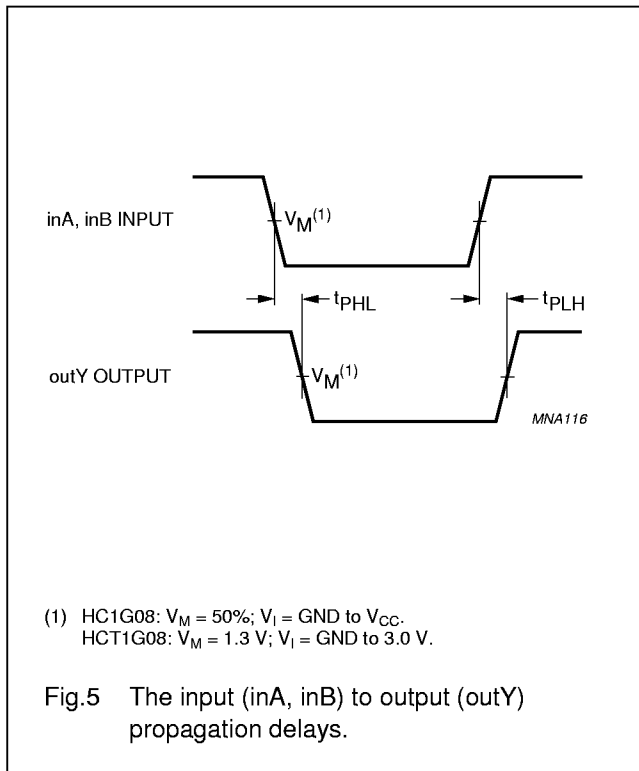

2-input AND gate

74HC1G08;
74HCT1G08

PACKAGE OUTLINE

Plastic surface mounted package; 5 leads

SOT353

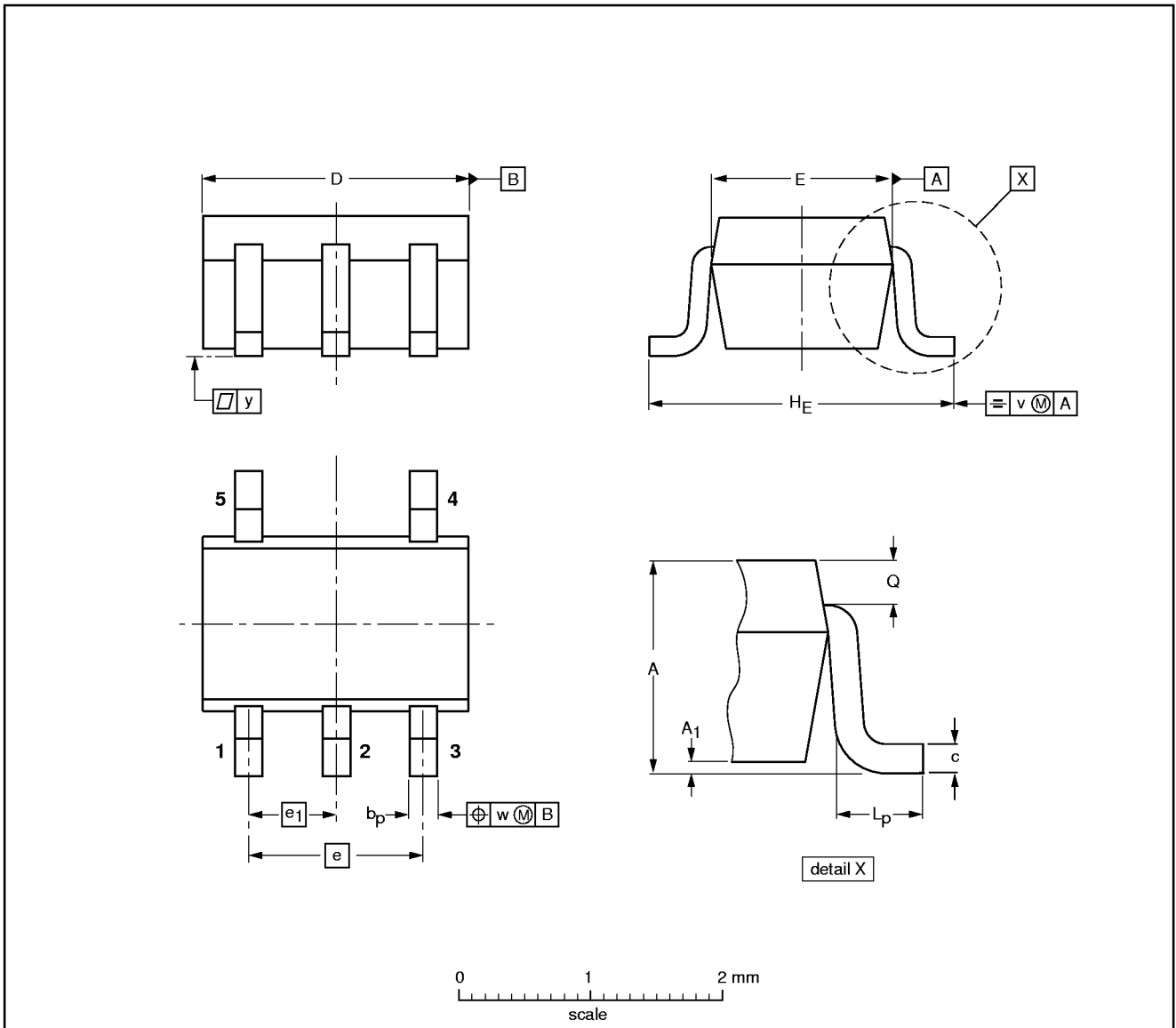

DIMENSIONS (mm are the original dimensions)

UNIT	A	A1 max	bp	c	D	E ⁽²⁾	e	e1	HE	Lp	Q	v	w	y
mm	1.1 0.8	0.1	0.30 0.20	0.25 0.10	2.2 1.8	1.35 1.15	1.3	0.65	2.2 2.0	0.45 0.15	0.25 0.15	0.2	0.2	0.1

OUTLINE VERSION	REFERENCES				EUROPEAN PROJECTION	ISSUE DATE
	IEC	JEDEC	EIAJ			
SOT353			SC-88A			97-02-28

2-input AND gate

74HC1G08;
74HCT1G08

SOLDERING

Introduction

There is no soldering method that is ideal for all IC packages. Wave soldering is often preferred when through-hole and surface mounted components are mixed on one printed-circuit board. However, wave soldering is not always suitable for surface mounted IC's, or for printed-circuits with high population densities. In these situations reflow soldering is often used.

This text gives a very brief insight to a complex technology. A more in-depth account of soldering IC's can be found in our *"Data Handbook IC26; Integrated Circuit Packages"* (order code 9398 652 90011).

Reflow soldering

Reflow soldering techniques are suitable for all SO packages.

Reflow soldering requires solder paste (a suspension of fine solder particles, flux and binding agent) to be applied to the printed-circuit board by screen printing, stencilling or pressure-syringe dispensing before package placement.

Several techniques exist for reflowing; for example, thermal conduction by heated belt. Dwell times vary between 50 and 300 seconds depending on heating method. Typical reflow temperatures range from 215 to 250 °C.

Preheating is necessary to dry the paste and evaporate the binding agent. Preheating duration: 45 minutes at 45 °C.

Wave soldering

Wave soldering techniques can be used for all SO packages if the following conditions are observed:

- A double-wave (a turbulent wave with high upward pressure followed by a smooth laminar wave) soldering technique should be used.
- The longitudinal axis of the package footprint must be parallel to the solder flow.
- The package footprint must incorporate solder thieves at the downstream end.

During placement and before soldering, the package must be fixed with a droplet of adhesive. The adhesive can be applied by screen printing, pin transfer or syringe dispensing. The package can be soldered after the adhesive is cured.

Maximum permissible solder temperature is 260 °C, and maximum duration of package immersion in solder is 10 seconds, if cooled to less than 150 °C within 6 seconds. Typical dwell time is 4 seconds at 250 °C.

A mildly-activated flux will eliminate the need for removal of corrosive residues in most applications.

Repairing soldered joints

Fix the component by first soldering two diagonally-opposite end leads. Use only a low voltage soldering iron (less than 24 V) applied to the flat part of the lead. Contact time must be limited to 10 seconds at up to 300 °C. When using a dedicated tool, all other leads can be soldered in one operation within 2 to 5 seconds between 270 and 320 °C.

2-input AND gate

74HC1G08;
74HCT1G08

DEFINITIONS

Data sheet status	
Objective specification	This data sheet contains target or goal specifications for product development.
Preliminary specification	This data sheet contains preliminary data; supplementary data may be published later.
Product specification	This data sheet contains final product specifications.
Limiting values	
Limiting values given are in accordance with the Absolute Maximum Rating System (IEC 134). Stress above one or more of the limiting values may cause permanent damage to the device. These are stress ratings only and operation of the device at these or at any other conditions above those given in the Characteristics sections of the specification is not implied. Exposure to limiting values for extended periods may affect device reliability.	
Application information	
Where application information is given, it is advisory and does not form part of the specification.	

LIFE SUPPORT APPLICATIONS

These products are not designed for use in life support appliances, devices, or systems where malfunction of these products can reasonably be expected to result in personal injury. Philips customers using or selling these products for use in such applications do so at their own risk and agree to fully indemnify Philips for any damages resulting from such improper use or sale.