

## CATV and VHF TV Tuner

**For the availability of this product, please contact the sales office.**

### Description

CXA1165P/M is a bipolar IC designed for CATV and VHF television tuners. It is composed of a local oscillator, mixer, IF amplifier, UIF amplifier, VHF/UIF change-over switch and a constant impedance output circuit.

This IC is fitted with a built-in regulator. Applying an external resistor makes it ideal for 9V and 12V tuners.

Major electrical characteristics are identical to those of CXA1125P/M.

### Features

- Low oscillator signal leakage.
- Operating frequency 55 MHz to 470 MHz.
- Built-in regulator

### Functions

- Local oscillator, mixer, IF amplifier and UIF amplifier.
- VHF/UIF change-over switch and constant impedance IF output amplifier.

### Structure

Bipolar silicon monolithic IC

### Applications

- CATV, CTV tuner.
- FM detector of 2nd IF for satellite broadcasting.
- 2nd mixer for CATV Up-Down converter.

### Absolute Maximum Ratings (Ta = 25°C)

- |                               |                           |             |    |
|-------------------------------|---------------------------|-------------|----|
| • Supply voltage              | V <sub>cc</sub>           | 10          | V  |
| • Operating temperature       | T <sub>opr</sub>          | -20 to +75  | °C |
| • Storage temperature         | T <sub>stg</sub>          | -55 to +150 | °C |
| • Allowable power dissipation | P <sub>D</sub> (CXA1165P) | 0.96        | W  |
|                               | P <sub>D</sub> (CXA1165M) | 0.80        | W  |

### Recommended Operating Condition

- |                  |                 |            |   |
|------------------|-----------------|------------|---|
| • Supply voltage | V <sub>cc</sub> | 6.5 to 9.5 | V |
|------------------|-----------------|------------|---|

14 pin DIP (Plastic)

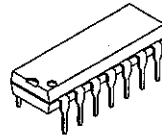

14 pin SOP (Plastic)

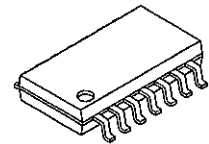

Sony reserves the right to change products and specifications without prior notice. This information does not convey any license by any implication or otherwise under any patents or other right. Application circuits shown, if any, are typical examples illustrating the operation of the devices. Sony cannot assume responsibility for any problems arising out of the use of these circuits.

[查询"CXA1165P"供应商](#)

### Block Diagram and Pin Configuration (Top View)

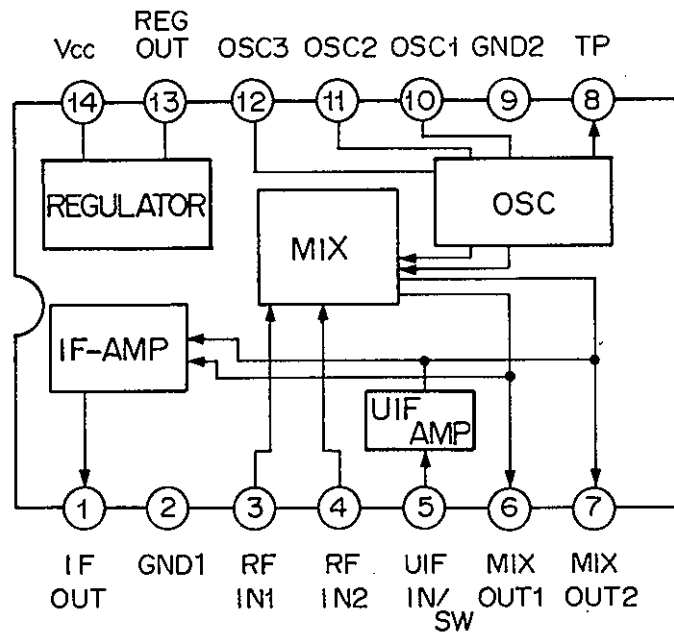

### Pin Description

No.	Symbol	Description	DC voltage (V)
1	IF OUT	IF signal output	2.5
2	GND1	IF amplifier system ground	0
3	RF IN1	RF signal input 1	2.0
4	RF IN2	RF signal input 2	2.0
5	UIF IN/SW	OFF during VHF received, ON during UIF received and UIF signal input.	OFF 0.0 ON 5.0
6	MIX OUT1	Mixer IF output 1	4.0
7	MIX OUT2	Mixer IF output 2	4.0
8	TP	Test point	3.8
9	GND2	Oscillator, mixer system ground	0
10	OSC1	External oscillator tank circuit output 1	2.4
11	OSC2	External oscillator tank circuit output 2	2.4
12*	OSC3	External oscillator tank circuit output 3	5
13	REG OUT	Regulator output	5
14	Vcc	Power supply	6.5 to 9.5

Note \*) As pin 12 is an open collector, it connects the choke coil to the regulator output through a damping resistance.

[查询"CXA1165P"供应商](#)

## Electrical Characteristics

### DC characteristics

$T_a = 25^\circ\text{C}$ ,  $V_{cc} = 9\text{V}$

Item	Symbol	Conditions	Min.	Typ.	Max.	Unit
Circuit current 1	I <sub>b1</sub>	SW OFF	37	46	57	mA
Circuit current 2	I <sub>b2</sub>	SW ON	27	35	46	mA

DC characteristics test circuit See Fig. 1.

### DC pin voltage characteristics

$T_a = 25^\circ\text{C}$ ,  $V_{cc} = 9\text{V}$

Item No.	Switch conditions	Typ.	Unit	Switch conditions	Typ.	Unit
1	SW OFF	2.5	V	SW ON	2.5	V
3	SW OFF	2.0	V	SW ON	0.0	V
4	SW OFF	2.0	V	SW ON	0.0	V
6	SW OFF	4.0	V	SW ON	5.0	V
7	SW OFF	4.0	V	SW ON	3.8	V
8	SW OFF	3.8	V	SW ON	4.2	V
10	SW OFF	2.4	V	SW ON	1.2	V
11	SW OFF	2.4	V	SW ON	1.2	V
13	SW OFF	5.0	V	SW ON	5.0	V

DC characteristics test circuit See Fig.1.

### AC characteristics

$T_a = 25^\circ\text{C}$ ,  $+B = 9\text{V}$

Item	Symbol	Test conditions	Min.	Typ.	Max.	Unit
UIF power gain	UIF PG	$f_{\text{UIF}} = 43.5\text{MHz}$	30	35	38	dB
RF conversion gain 1	CG1	$f_{\text{RF}} = 55\text{MHz}$	23	28	32	dB
RF conversion gain 2	CG2	$f_{\text{RF}} = 470\text{MHz}$	20	25	28	dB
UIF noise figure	UIF NF	$f_{\text{UIF}} = 43.5\text{MHz}$		3.0	6.5	dB
RF noise figure 1	NF1	$f_{\text{RF}} = 55\text{MHz}$		8.5	11.0	dB
RF noise figure 2	NF2	$f_{\text{RF}} = 470\text{MHz}$		14.0	16.5	dB

AC characteristics test circuit See Fig. 2.

[查询"CXA1165P"供应商](#)

Standard circuit design data

Ta = 25°C, +B = 9V

Item	Symbol	Test conditions	Typ.	Unit
UIF gain deviation	$\Delta PG$	$f_s = 41.25\text{MHz}$ $f_p = 45.75\text{MHz}$ $\Delta PG =  f_s - f_p $	0.3	dB
UIF Input impedance	$r_{uip}$	$f = 45.75\text{MHz}$ , Input level - 30dBm	600	$\Omega$
	$C_{uip}$		10	pF
RF Input impedance	$r_{ip}$	$f = 470\text{MHz}$ , Input level - 30dBm	1.5	k $\Omega$
	$C_{ip}$		2.8	pF
IF output voltage standing wave ratio	VSWR	$f = 43.5\text{MHz}$ , Input level - 30dBm ( $Z_0 = 50\Omega$ )	1.5	
UIF 1% cross modulation distortion	UIF CM	$f_{Des} = 45.75\text{MHz}$ , Input level 60dB $\mu$ $f_{Undes} = f_{Des} \pm 12\text{MHz}$ , 1kHz 40% AM 75 $\Omega$ open value	83	dB $\mu$
1% cross modulation distortion 1 (55 MHz)	CM 1	$f_{Des} = 55\text{MHz}$ , Input level 60dB $\mu$ $f_{Undes} = f_{Des} \pm 12\text{MHz}$ , 1kHz 40% AM 75 $\Omega$ open value	93	dB $\mu$
1% cross modulation distortion 2 (470MHz)	CM 2	$f_{Des} = 470\text{MHz}$ , Input level 60dB $\mu$ $f_{Undes} = f_{Des} \pm 12\text{MHz}$ , 1kHz 40% AM 75 $\Omega$ open value	95	dB $\mu$
IF Maximum output power*	POMAX	$f_p = 45.75\text{MHz}$ $f_s = 41.25\text{MHz}$ $f_c = 42.17\text{MHz}$	- 1.5	dBm

Note\*) As shown in the diagram at right, when the level difference between  $f_p$  and the beat within the band area reaches 40 dB,  $f_p$  maximum output level is indicated.

AC characteristics test circuit See Fig. 2.

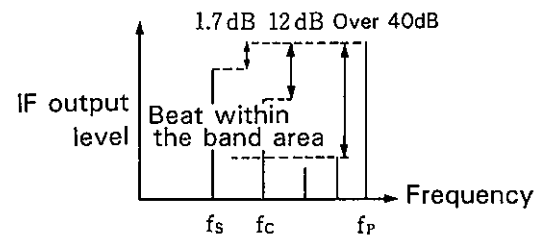

Electrical characteristics test circuit

1. DC characteristics test circuit

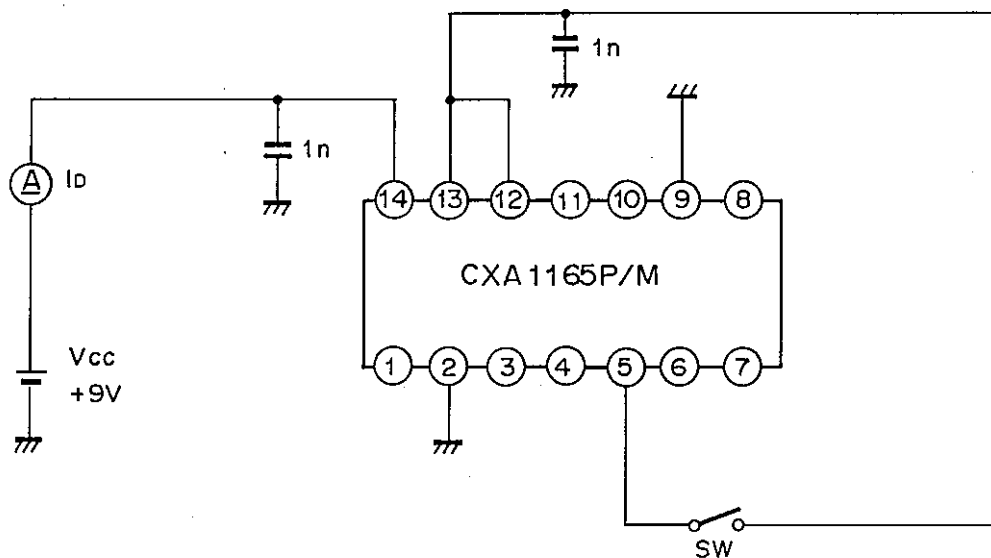

Fig. 1

Note) SW ON during UIF test

[查询"CXA1165P"供应商](#)

2. AC characteristics test circuit

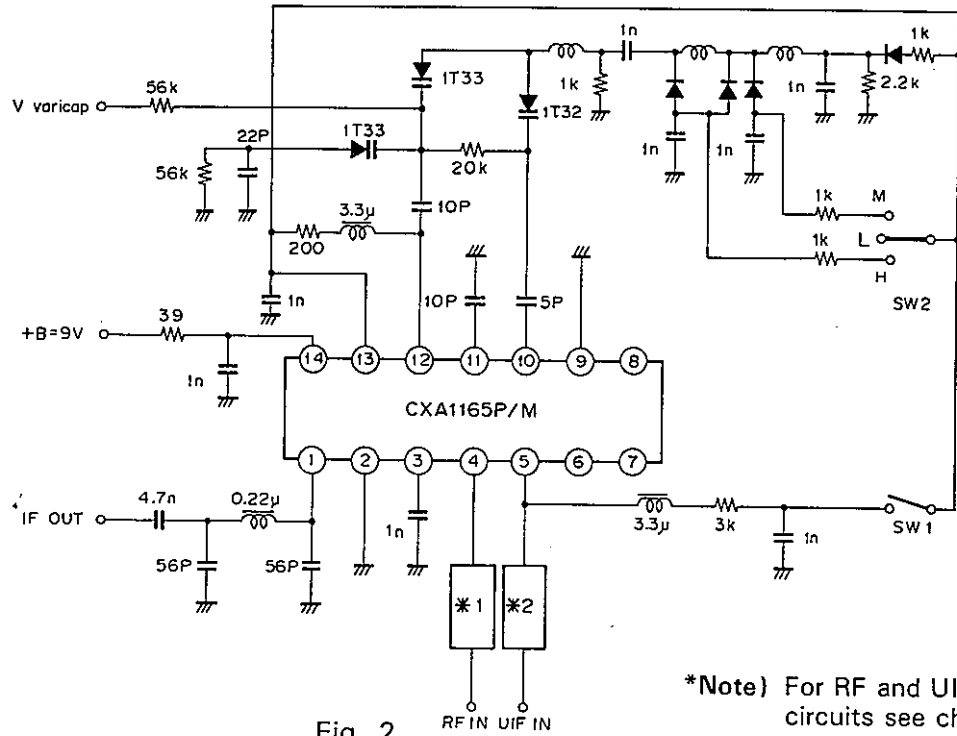

Fig. 2

\*Note) For RF and UIF input circuits see chart below.

SW · Input circuit conditions

Test item	SW1	SW2	RF input circuit	UIF input circuit
UIF PG · NF	ON	—		
CG1 · NF1 (RF = 55 MHz)	OFF	L		
CG2 · NF2 (RF = 470 MHz)	OFF	H		
UIF CM UIF gain deviation UIF input impedance	ON	—		
CM 1 (55 MHz) CM 2 (470 MHz) RF input impedance	OFF	L H		

[查询"CXA1165P"供应商](#)**Operation description (For AC characteristics test circuit, See Fig. 2)****1) Voltage power supply circuit**

It features a built-in voltage regulator; pin 14 is the power supply pin and pin 13 the output pin. 6.5 to 9.5V voltage is applied to pin 14. For use in a +B=9 to 12V tuner, insert in series a resistor between the circuit and pin 14, keep the voltage applied to pin 14 to a level within that recommended range. During UHF received rather than the ability to flow out a current of about 10mA from pin 13, it can be used as supply for UHF local OSC.

**2) Oscillator circuit**

The Oscillator consists of an positive feedback amplifier with pin 10 for input and pin 12 for output, combined with an LC tank circuit that includes variable capacitors. As pin 12 is an open collector, insert in series a choke coil and a damping resistor of about 200 $\Omega$  and connect to pin 13. The oscillating frequency can be varied by varying the variable capacitor voltage. By switching the resonance coils with a switching diodes, oscillation is obtained on a wide band range 100 to 520 MHz.

**3) Mixer circuit**

This mixer is a double balanced mixer where local signal leakage is minimal, and stably operated on a wide band range. There are two methods for RF signal input. One, where either pin 3 or 4 is grounded with a capacitor, while the other is for input. The other where input is done to both pins 3 and 4 differentially. Input RF signals are converted in the mixer to IF signals, and it can be taken from pins 6 and 7.

**4) IF circuit**

IF signals from the mixer are amplified in the IF circuit and taken from pin 1. The output impedance is 75 $\Omega$ .

**5) UIF circuit**

During UHF received, UIF signals converted to IF in the UHF system and the 5V DC voltage simultaneously applied to pin 5, operate as a UIF amplifier, and UIF signals amplified from pin 1 are obtained.

[查询"CXA1165P"供应商](#)

Application circuit-1

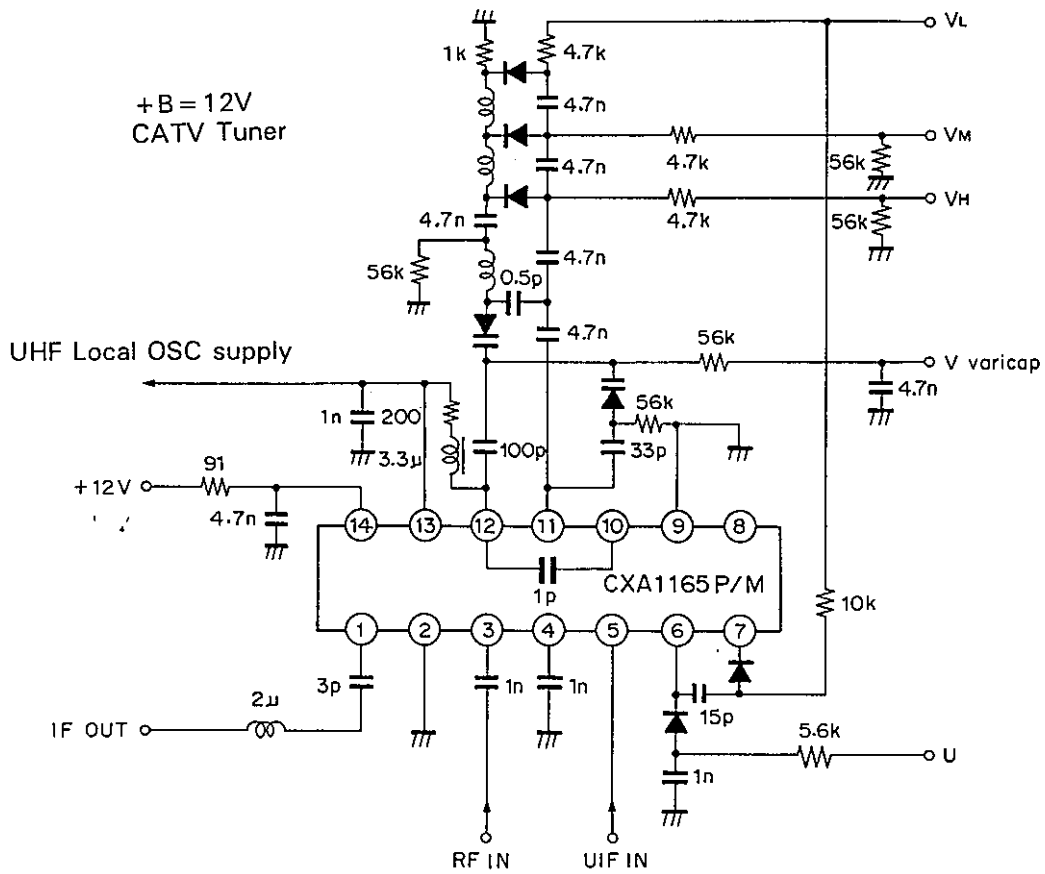

Fig. 3

Application circuit-2

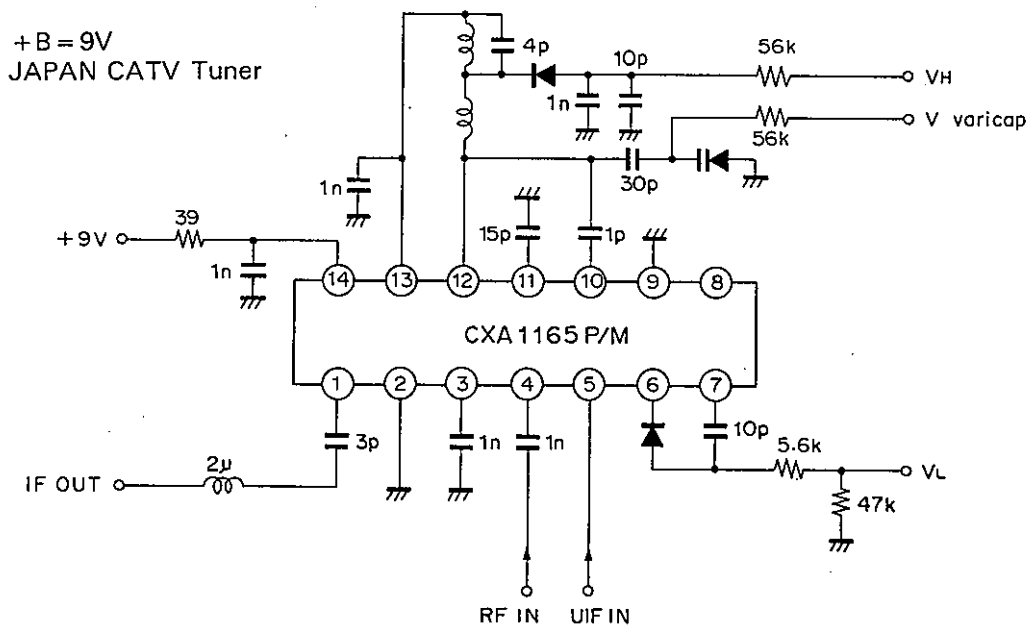

Fig. 4

[查询"CXA1165P"供应商](#)

**Application circuit-3**

CATV UP-DOWN converter second IF mixer

- Input frequency 610 MHz
- Output frequency 45.75MHz

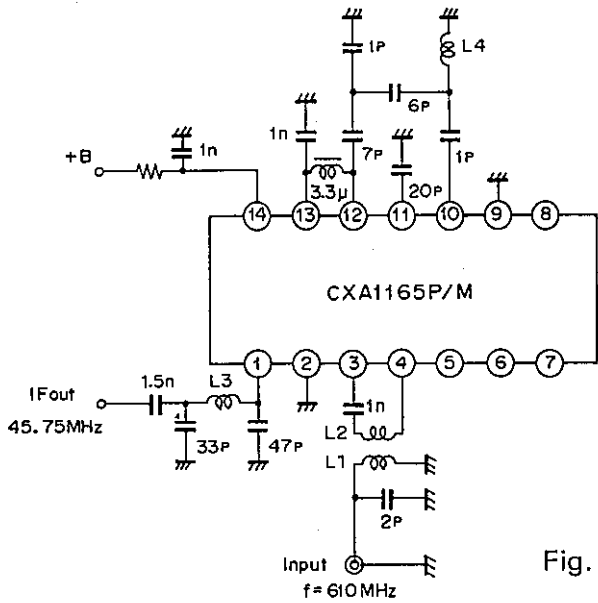

Fig. 5

Coil parameter

	Wire diameter	Coil diameter	Number of windings
L1	0.4mm	3.2mmφ	2 turn
L2	0.4	3.2	5.
L3	0.4	3.2	11.5
L4	0.4	4.0	2.5

**Application circuit-4**

400 to 500 MHz band FM detector application

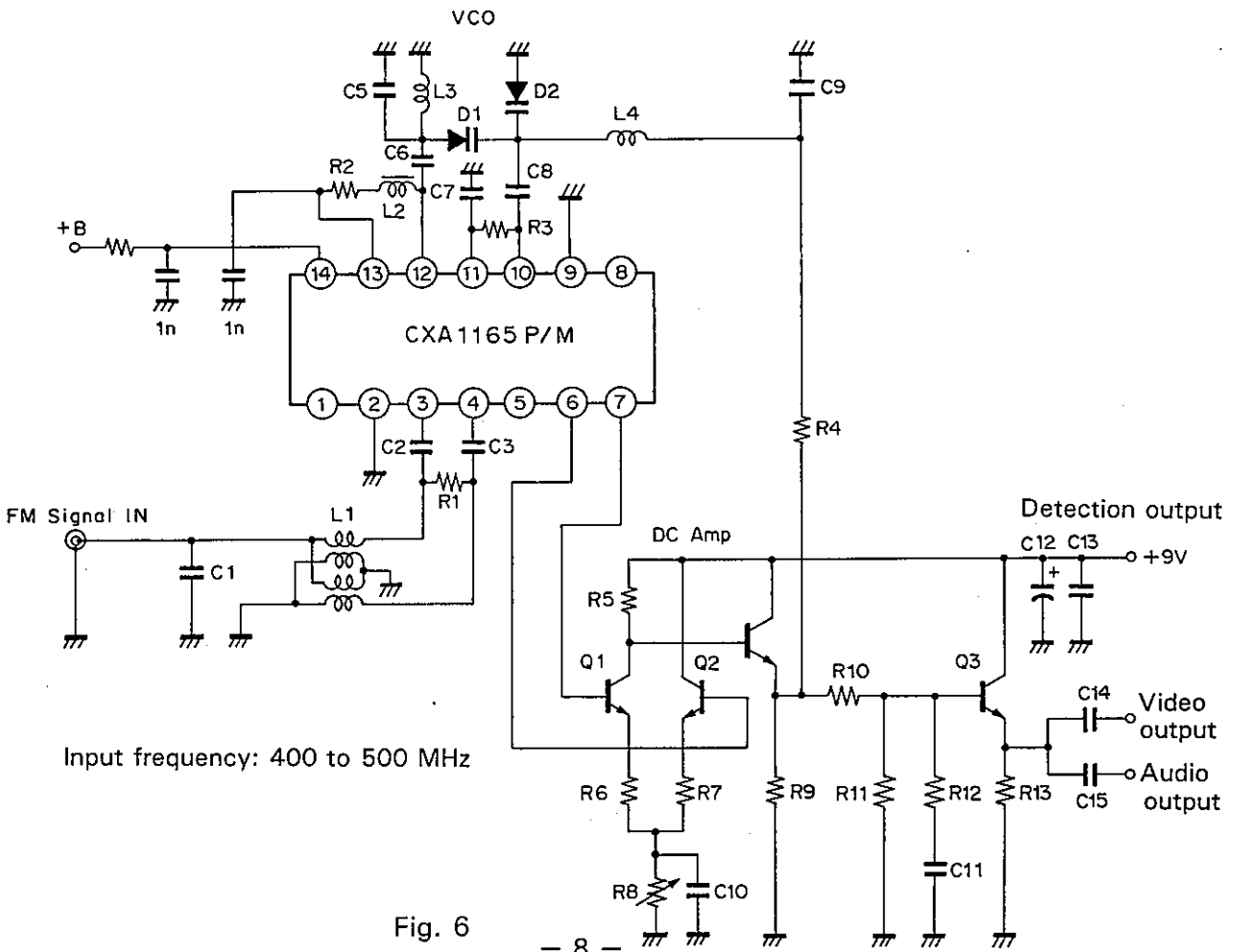

Fig. 6



[查询"CXA1165P"供应商](#)

**Application circuit-5**

Mix injection method through external oscillator

(1) Unbalance input

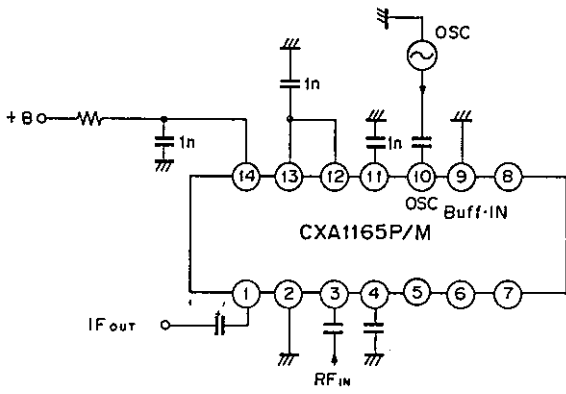

Fig. 7

(2) Unbalance input

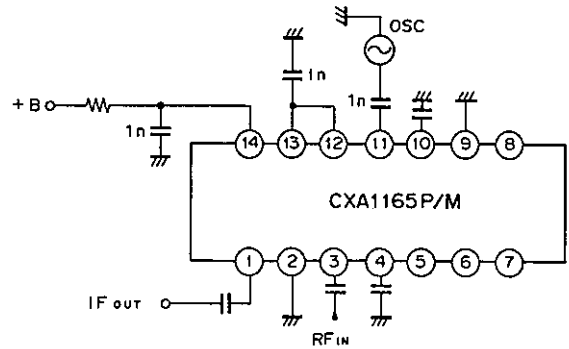

Fig. 8

(3) Balance input

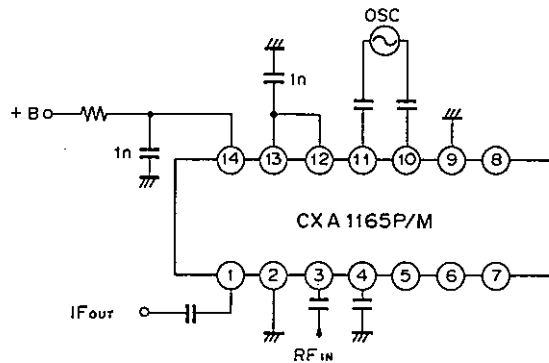

Fig. 9



[查询"CXA1165P"供应商](#)

Package Outline Unit: mm

14PIN DIP (PLASTIC)

CXA1165P

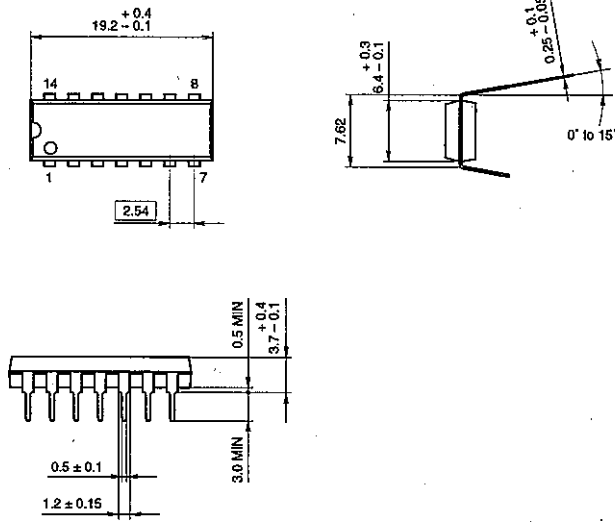

PACKAGE STRUCTURE

SONY CODE	DIP-14P-01
EIAJ CODE	DIP014-P-0300
JEDEC CODE	Similar to MO-001-AH

PACKAGE MATERIAL	EPOXY RESIN
LEAD TREATMENT	SOLDER PLATING
LEAD MATERIAL	42/COPPER ALLOY
PACKAGE MASS	0.9g

14PIN DIP (PLASTIC)

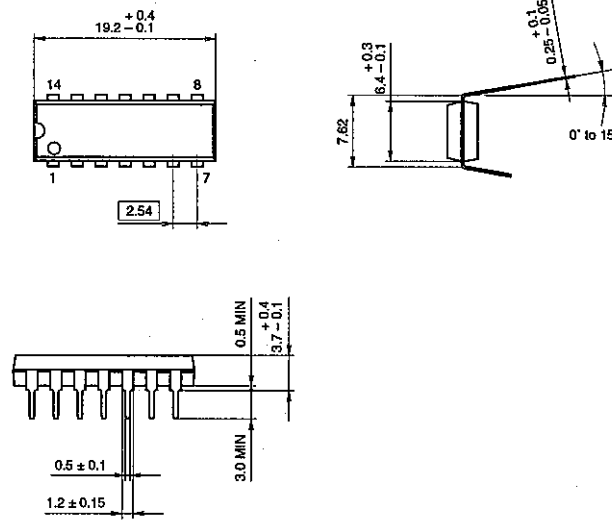

PACKAGE STRUCTURE

SONY CODE	DIP-14P-01
EIAJ CODE	DIP014-P-0300
JEDEC CODE	Similar to MO-001-AH

PACKAGE MATERIAL	EPOXY RESIN
LEAD TREATMENT	SOLDER PLATING
LEAD MATERIAL	42/COPPER ALLOY
PACKAGE MASS	0.9g

LEAD PLATING SPECIFICATIONS

ITEM	SPEC.
LEAD MATERIAL	COPPER ALLOY
SOLDER COMPOSITION	Sn-Bi Bi:1-4wt%
PLATING THICKNESS	5-18µm

[查询"CXA1165P"供应商](#)

Package Outline Unit: mm

14PIN SOP (PLASTIC)

CXA1165M

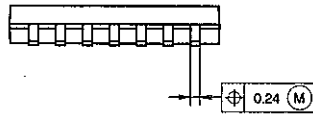
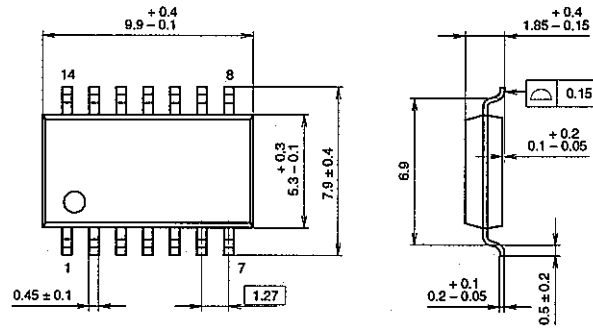

SONY CODE	SOP-14P-L01
EIAJ CODE	SOP014-P-0300
JEDEC CODE	

PACKAGE STRUCTURE

PACKAGE MATERIAL	EPOXY RESIN
LEAD TREATMENT	SOLDER PLATING
LEAD MATERIAL	42/COPPER ALLOY
PACKAGE MASS	0.2g

14PIN SOP (PLASTIC)

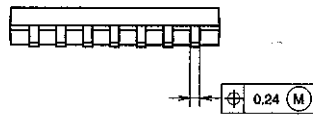
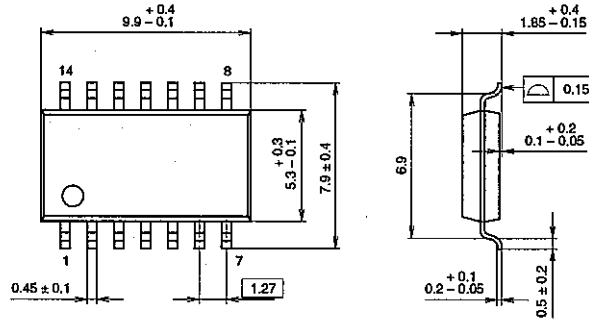

SONY CODE	SOP-14P-L01
EIAJ CODE	SOP014-P-0300
JEDEC CODE	

PACKAGE STRUCTURE

PACKAGE MATERIAL	EPOXY RESIN
LEAD TREATMENT	SOLDER PLATING
LEAD MATERIAL	42/COPPER ALLOY
PACKAGE MASS	0.2g

LEAD PLATING SPECIFICATIONS

ITEM	SPEC.
LEAD MATERIAL	COPPER ALLOY
SOLDER COMPOSITION	Sn-Bi Bi:1-4wt%
PLATING THICKNESS	5-18μm