

### FEATURES

- Digital triple-axis accelerometer,  $\pm 19 g$**
- Programmable event recorder**
  - Internal and external trigger inputs
- Low power operation**
  - Sleep mode current: 100  $\mu A$
  - Continuous sampling current: 1 mA, 1 kSPS
- Wake-up and record function**
  - External trigger input and SPI trigger command
- Peak acceleration sample-and-hold**
- Peak XYZ sum-of-squares output**
- 1600 Hz (X, Y) and 550 Hz (Z) sensor bandwidth**
- Digitally controlled bias correction**
- Digitally controlled sample rate, up to 4096 SPS**
- Programmable alarms for condition monitoring**
- Programmable digital input/output lines**
  - Data-ready output and alarm indicator output
- Real-time clock**
- Digitally activated self-test**
- Embedded temperature sensor**
- Programmable power management**
- SPI-compatible serial interface**
- Auxiliary 10-bit ADC input**
- Two analog trigger inputs with programmable threshold**
- Single-supply operation: 2.4 V to 3.6 V**
- >4000 g powered shock survivability**

### APPLICATIONS

- Crash or impact detection
- Condition monitoring of valuable goods
- Safety, shut-off sensing
- Impact event recording
- Security sensing and tamper detection

### GENERAL DESCRIPTION

The ADIS16240 is a fully integrated digital shock detection and recorder system. It combines industry-leading iMEMS® technology with a signal processing solution that optimizes dynamic performance for low power applications. The triple-axis sensing element enables shock measurement in all directions, eliminating the need for additional sensors and complex mechanical structures for many applications. The digital serial peripheral interface (SPI) uses four wires and is compatible with most processor platforms. The SPI interface provides access to sensor data and a set of configuration registers that control such operational parameters as offset bias correction, sample rate, sleep mode, peak detection, and event capture.

#### Rev. 0

Information furnished by Analog Devices is believed to be accurate and reliable. However, no responsibility is assumed by Analog Devices for its use, nor for any infringements of patents or other rights of third parties that may result from its use. Specifications subject to change without notice. No license is granted by implication or otherwise under any patent or patent rights of Analog Devices. Trademarks and registered trademarks are the property of their respective owners.

### FUNCTIONAL BLOCK DIAGRAM

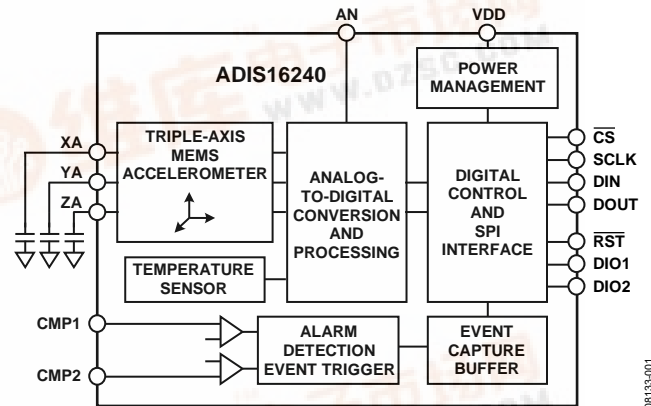

Figure 1.

The programmable event recorder offers two trigger modes. The internal mode monitors continuous sampled data and triggers the capture, based on the user-defined threshold. The external mode uses the two comparator inputs and a user-defined threshold to trigger the event captures. This function also provides user configuration controls for capture length, pretrigger data, and data storage. Each event is stored with a header that captures temperature, power supply, and time. Several power management features, including sleep mode and a wake-up function, enable power optimization with respect to specific mechanical system requirements.

The ADIS16240 is available in a 12 mm × 12 mm laminate-based ball grid array (BGA) that meets IPC/JEDEC standards for Pb-free solder reflow processing (J-STD-020C and J-STD-033).



## TABLE OF CONTENTS

Features .....	1	Sensing Element .....	8
Applications.....	1	Data Sampling and Processing .....	8
Functional Block Diagram .....	1	User Interface.....	8
General Description .....	1	Capture .....	8
Revision History .....	2	Basic Operation .....	9
Specifications.....	3	Memory Map .....	10
Timing Specifications .....	4	Output Data Registers .....	11
Absolute Maximum Ratings.....	5	Event Recorder .....	12
ESD Caution.....	5	Operational Control.....	14
Pin Configuration and Function Descriptions.....	6	Outline Dimensions .....	16
Typical Performance Characteristics .....	7	Ordering Guide .....	16
Theory of Operation .....	8		

## REVISION HISTORY

4/09—Revision 0: Initial Version

## SPECIFICATIONS

$T_A = 25^\circ\text{C}$ ,  $V_{DD} = 2.4\text{ V}$  to  $3.6\text{ V}$  unless otherwise noted.

Table 1.

Parameter	Conditions	Axis	Min	Typ	Max	Unit
<b>ACCELEROMETER</b>						
Dynamic Range			$\pm 16$	$\pm 19$		<i>g</i>
Initial Sensitivity				51.4		mg/LSB
Sensitivity Temperature Coefficient	$-40^\circ\text{C}$ to $+85^\circ\text{C}$			$\pm 0.01$		%
Sensitivity Change with Supply Voltage	$2.4\text{ V} < V_{DD} < 3.6\text{ V}$	X, Y		6		%
Nonlinearity	Compare with best fit line			$\pm 2$		% FS
Sensor-to-Sensor Alignment Error				$\pm 0.1$		Degrees
Cross-Axis Sensitivity				$\pm 1$		%
Initial Bias Error			$-2.7$		$+2.7$	<i>g</i>
Bias Temperature Coefficient				$\pm 1$		mg/ $^\circ\text{C}$
Bias Voltage Sensitivity				TBD		mg/V
Output Noise				24		mg rms
Noise Density				480		$\mu\text{g}/\sqrt{\text{Hz}}$
Bandwidth	No external capacitance	X, Y		1600		Hz
	No external capacitance	Z		550		Hz
Sensor Resonant Frequency				5.5		kHz
Self-Test Change in Output Response		X	$-10$	$-21$	$-39$	LSB
		Y	$+10$	$+21$	$+39$	LSB
		Z	$+10$	$+36$	$+65$	LSB
TEMPERATURE SENSOR SCALE FACTOR	TEMP_OUT = 0x0133 (307) at $25^\circ\text{C}$			0.244		$^\circ\text{C}/\text{LSB}$
<b>ADC INPUT</b>						
Input Range			0		$V_{DD}$	V
Resolution				10		Bits
Integral Nonlinearity, INL				$\pm 1$	$\pm 2$	LSB
Differential Nonlinearity, DNL				$\pm 1$	$\pm 1.25$	LSB
Offset Error				$\pm 1$	$\pm 2$	LSB
Gain Error				$\pm 1$	$\pm 3$	LSB
Input Capacitance				11		pF
<b>LOGIC INPUTS<sup>1</sup></b>						
Input High Voltage, $V_{INH}$			2.0			V
Input Low Voltage, $V_{INL}$					0.8	V
Logic 1 Input Current, $I_{INH}$	$V_{IH} = V_{DD}$			$\pm 0.2$	$\pm 1$	$\mu\text{A}$
Logic 0 Input Current, $I_{INL}$	$V_{IL} = 0\text{ V}$			$-40$	$-60$	$\mu\text{A}$
Input Capacitance, $C_{IN}$				10		pF
<b>DIGITAL OUTPUTS</b>						
Output High Voltage, $V_{OH}$	$I_{SOURCE} = 1.6\text{ mA}$		2.4			V
Output Low Voltage, $V_{OL}$	$I_{SINK} = 1.6\text{ mA}$				0.4	V
<b>START-UP TIME</b>						
Initial, Reset Recovery					32	ms
<b>FLASH MEMORY</b>						
Endurance <sup>2</sup>			10,000			Cycles
Data Retention <sup>3</sup>	$T_J = 85^\circ\text{C}$		20			Years
CONVERSION RATE SETTING					4096	SPS
<b>POWER SUPPLY</b>						
Average Supply Current <sup>4</sup>	SMPL_PRD = 0x1F, $V_{DD} = 2.5\text{ V}$		2.4		3.6	V
Sleep Mode Current				1		mA
				100		$\mu\text{A}$

<sup>1</sup> Note that the inputs are 5 V tolerant.

<sup>2</sup> Endurance is qualified as per JEDEC Standard 22, Method A117 and measured at  $-40^\circ\text{C}$ ,  $+25^\circ\text{C}$ ,  $+85^\circ\text{C}$ , and  $+105^\circ\text{C}$ .

<sup>3</sup> Retention lifetime equivalent at junction temperature ( $T_J$ ) of  $55^\circ\text{C}$  as per JEDEC Standard 22, Method A117. Retention lifetime decreases with junction temperature.

<sup>4</sup> Instantaneous current has periodic peaks at the sample rate that can reach 30 mA.

## TIMING SPECIFICATIONS

$T_A = 25^\circ\text{C}$ ,  $V_{DD} = 3.3\text{ V}$ , unless otherwise noted.

Table 2.

Parameter	Description	Min <sup>1</sup>	Typ	Max <sup>1</sup>	Unit
$f_{\text{SCLK}}$	Serial clock rate <sup>2</sup>	0.01		2.5	MHz
$t_{\text{DATARATE}}$	Chip select period <sup>2</sup>	60			$\mu\text{s}$
$t_{\text{CS}}$	Chip select to clock edge	120			ns
$t_{\text{DAV}}$	Data output valid after SCLK edge			30	ns
$t_{\text{DSU}}$	Data input setup time before SCLK rising edge	20			ns
$t_{\text{DHD}}$	Data input hold time after SCLK rising edge	20			ns
$t_{\text{DF}}$	Data output fall time		10	25	ns
$t_{\text{DR}}$	Data output rise time		10	25	ns
$t_{\text{SFS}}$	CS high after SCLK edge	430			ns

<sup>1</sup> Guaranteed by design; typical specifications are not tested or guaranteed.

<sup>2</sup> Based on sample rate selection.

### Timing Diagrams

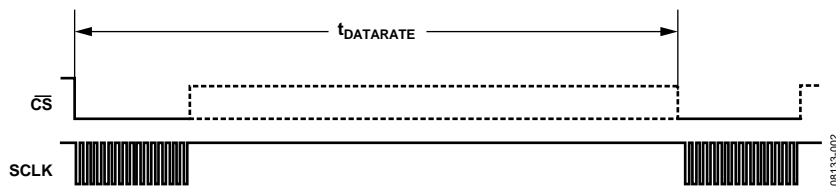

Figure 2. SPI Chip Select Timing

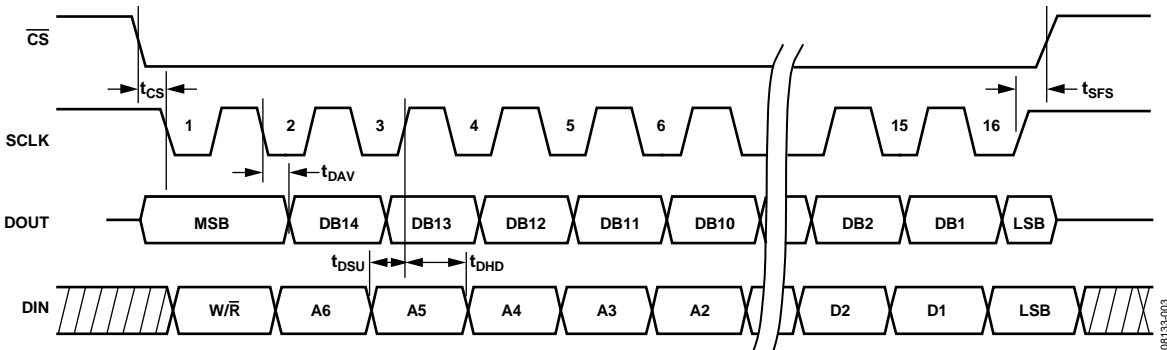

Figure 3. SPI Timing (Utilizing SPI Settings Typically Identified as Phase = 1, Polarity = 1)

## ABSOLUTE MAXIMUM RATINGS

Table 3.

Parameter	Rating
Acceleration	
Any Axis, Unpowered	2000 <i>g</i>
Any Axis, Powered	2000 <i>g</i>
VDD to GND	−0.3 V to +3.6 V
Digital Input Voltage to GND	−0.3 V to $V_{DD} + 0.3$ V
Analog Inputs to GND	−0.3 V to $V_{DD} + 0.3$ V
Operating Temperature Range	−40°C to +85°C
Storage Temperature Range	−65°C to +150°C

Stresses above those listed under Absolute Maximum Ratings may cause permanent damage to the device. This is a stress rating only; functional operation of the device at these or any other conditions above those indicated in the operational section of this specification is not implied. Exposure to absolute maximum rating conditions for extended periods may affect device reliability.

### ESD CAUTION



**ESD (electrostatic discharge) sensitive device.** Charged devices and circuit boards can discharge without detection. Although this product features patented or proprietary protection circuitry, damage may occur on devices subjected to high energy ESD. Therefore, proper ESD precautions should be taken to avoid performance degradation or loss of functionality.

# PIN CONFIGURATION AND FUNCTION DESCRIPTIONS

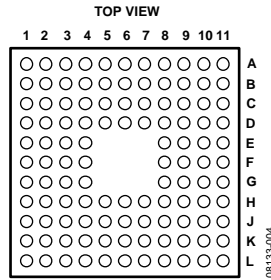

NOTES  
1. THE ACTUAL PINS ARE NOT VISIBLE FROM THE TOP VIEW.

Figure 4. Pin Configuration (Top View)

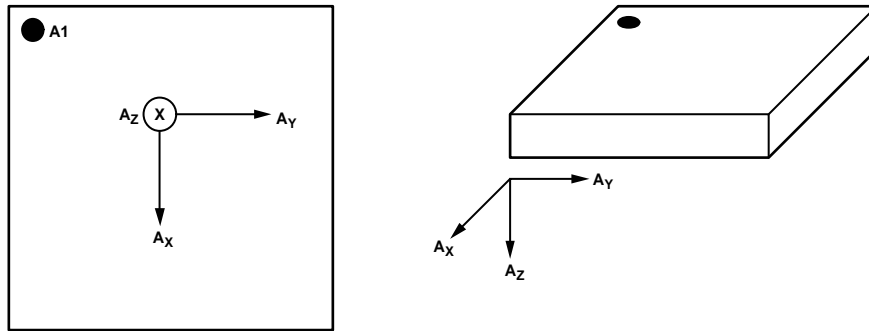

Figure 5. Axis Orientation of Device (Top View)

Table 4. Pin Function Descriptions

Pin No.	Mnemonic	Type <sup>1</sup>	Description
E10, E11	SCLK	I	SPI Serial Clock
F10, F11	$\overline{CS}$	I	SPI Chip Select, Active Low
G10, G11	DIN	I	SPI Data Input
H10, H11	DOUT	O	SPI Data Output
J10, J11	DIO2	I/O	Multifunction Digital Input/Output 2
K9, L9	DIO1	I/O	Multifunction Digital Input/Output 1
K8, L8	AN	I	Analog Input Channel
K7, L7	CMP2	I	Analog Comparator Input 2
K6, L6	CMP1	I	Analog Comparator Input 1
K3, L3	$\overline{RST}$	I	Reset, Active Low, No Pull-Up Resistor
J1, J2	XA	O	X-Axis Accelerometer Filter Pin
H1, H2	YA	O	Y-Axis Accelerometer Filter Pin
G1, G2	ZA	O	Z-Axis Accelerometer Filter Pin
A5, B5	ST	I	Self-Test Input Control Line
D4 to D8, E4, E8, F4, F8, G4, G8, H4 to H8	VDD	S	Power Supply, 3.3 V
A1, A2, A10, A11, B1, B2, B10, B11, C3 to C9, D3, D9, E3, E9, F3, F9, G3, G9, H3, H9, J3 to J9, K1, K2, K10, K11, L1, L2, L10, L11	GND	S	Ground
A3, A4, A6 to A9, B3, B4, B6 to B9, C1, C2, C10, C11, D1, D2, D10, D11, E1, E2, F1, F2, K4, K5, L4, L5	NC		No Connect

<sup>1</sup> I = input, O = output, I/O = input/output, S = supply.

### TYPICAL PERFORMANCE CHARACTERISTICS

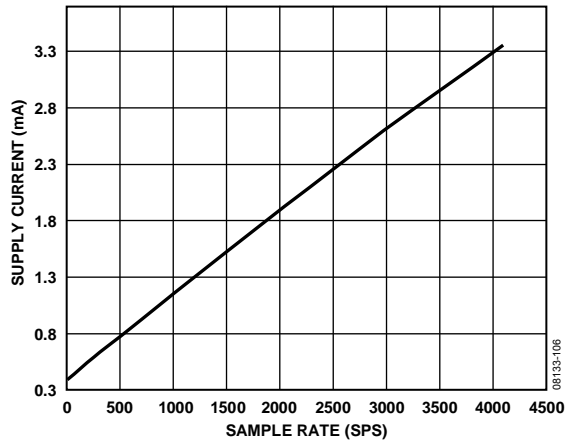

Figure 6. Supply Current vs. Sample Rate

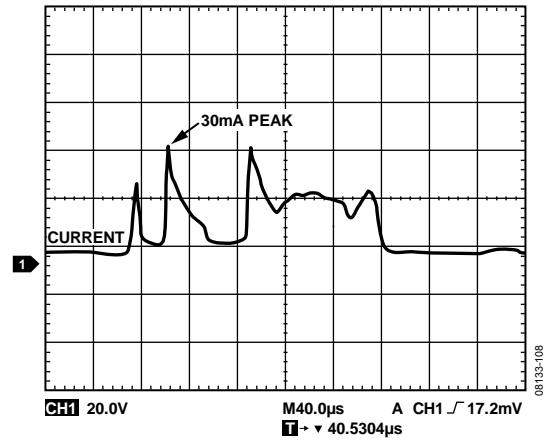

Figure 9. Instantaneous Supply Current

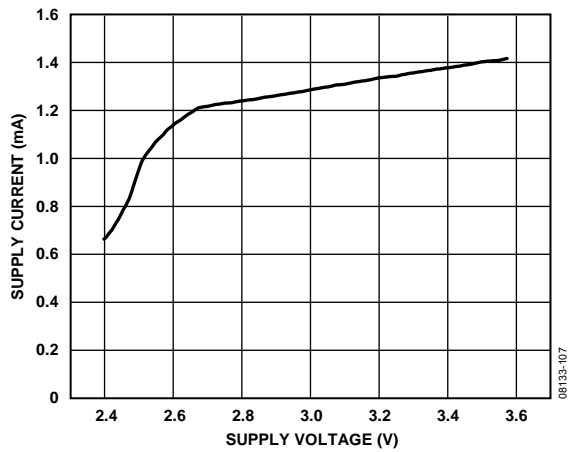

Figure 7. Supply Current vs. Supply Voltage

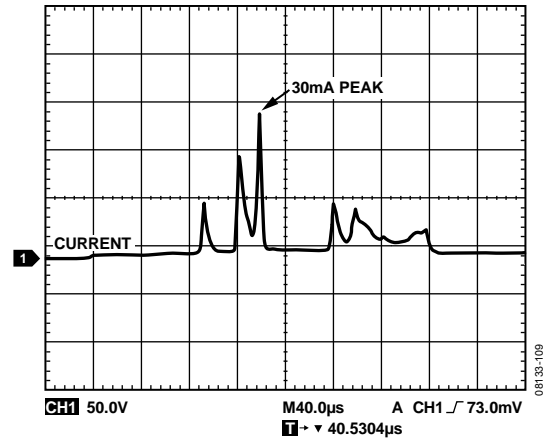

Figure 10. Instantaneous Supply Current

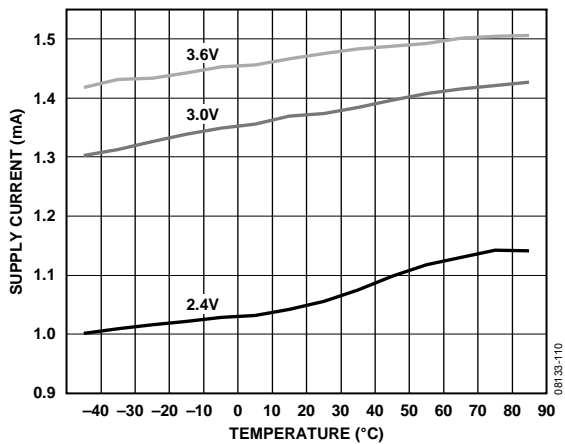

Figure 8. Supply Current vs. Temperature

## THEORY OF OPERATION

The ADIS16240 is a triple-axis accelerometer system for shock detection and recording applications. This sensing system collects data autonomously and makes it available to any processor system that supports a 4-wire serial peripheral interface (SPI).

### SENSING ELEMENT

Digital shock sensing starts with the triple-axis MEMS sensing element in the ADIS16240. This element provides a linear motion-to-electrical transducer function. Figure 11 provides a basic physical diagram of the sensing element and its response to linear acceleration. It uses a fixed frame and a moving frame to form a differential capacitance network that responds to linear acceleration. Tiny springs tether the moving frame to the fixed frame and govern the relationship between acceleration and physical displacement. A modulation signal on the moving plate feeds through each capacitive path into the fixed frame plates and into a demodulation circuit, which produces the electrical signal that is proportional to the acceleration acting on the device.

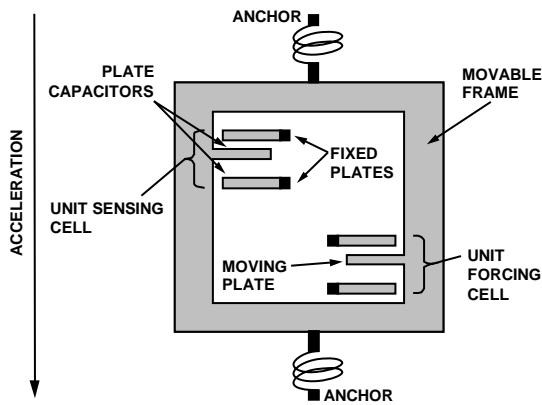

Figure 11. MEMS Sensor Diagram

08133-007

### DATA SAMPLING AND PROCESSING

The analog acceleration signals feed into an analog-to-digital converter stage that passes digitized data into the controller for data processing and capture. The ADIS16240 runs autonomously, based on the configuration in the user control registers.

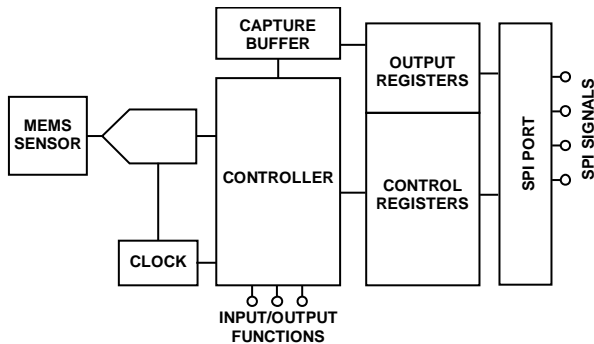

Figure 12. Simplified Sensor Signal Processing Diagram

08133-008

## USER INTERFACE

### SPI Interface

Data collection and configuration commands both use the SPI, which consists of four wires. The chip select ( $\overline{CS}$ ) signal activates the SPI interface, and the serial clock (SCLK) synchronizes the serial data lines. The serial input data clocks into DIN on the rising edge of SCLK, and the serial output data clocks out of DOUT on the falling edge of SCLK. Many digital processor platforms support this interface with dedicated serial ports and simple instruction sets.

### User Registers

The user registers provide addressing for all input/output operations on the SPI interface. Each 16-bit register has its own unique bit assignment and has two 7-bit addresses: one for its upper byte and one for its lower byte. Table 7 provides a memory map for each register and identifies output registers as read only (R) and configuration registers as either read/write (R/W) or write only (W). The control registers use a dual-memory structure. The SRAM controls operation while the part is on and facilitates all user configuration inputs. The flash memory provides nonvolatile storage for the control registers that are identified with a “yes” in the flash backup column in Table 7. Storing configuration data in the flash memory requires a manual command (see GLOB\_CMD[3] in Table 24). When the device starts up from an initial power-up or reset, the flash memory contents load into the SRAM. Then the device starts producing data according to the configuration in the control registers.

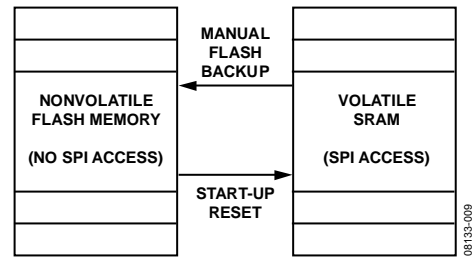

Figure 13. Control Registers—SRAM and Flash Memory Diagram

08133-009

### CAPTURE

The ADIS16240 offers a recorder function that captures acceleration information based on either internal or external triggers. The buffer memory is  $3 \times 8192$  samples and is capable of storing multiple trigger events.



## BASIC OPERATION

The ADIS16240 starts up automatically when it has a valid power supply and begins producing digital acceleration data in the output registers. When using the factory-default configuration, DIO1 serves as a data-ready indicator signal that can drive a processor interrupt function. Figure 14 shows a schematic for connecting to a SPI-compatible processor platform, referred to as the SPI master.

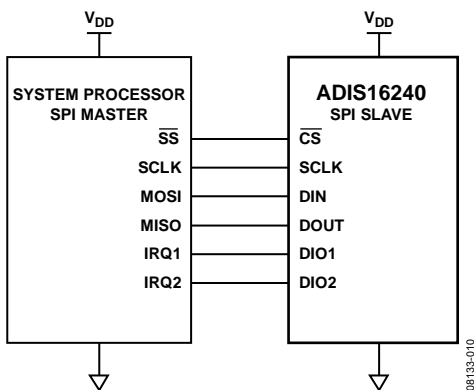

Figure 14. Electrical Hook-Up Diagram

Table 5. Generic Master Processor Pin Names and Functions

Pin Name	Function
SS	Slave select.
IRQ1, IRQ2	Interrupt request inputs.
MOSI	Master output, slave input.
MISO	Master input, slave output.
SCLK	Serial clock.

The ADIS16240 SPI interface supports full duplex serial communication (simultaneous transmit and receive) and uses the bit sequence shown in Figure 18. Processor platforms typically support SPI communication with general-purpose serial ports that require some configuration in their control registers. Table 6 lists the most common settings that require attention when initializing a processor serial port for communication with the ADIS16240.

Table 6. Generic Master Processor SPI Settings

Processor Setting	Description
Master	The ADIS16240 operates as a slave.
SCLK Rate ≤ 2.5 MHz	Bit rate setting.
SPI Mode 3 (1,1)	Clock polarity/phase (CPOL = 1, CPHA = 1).
MSB First	Bit sequence.
16-Bit	Shift register/data length.

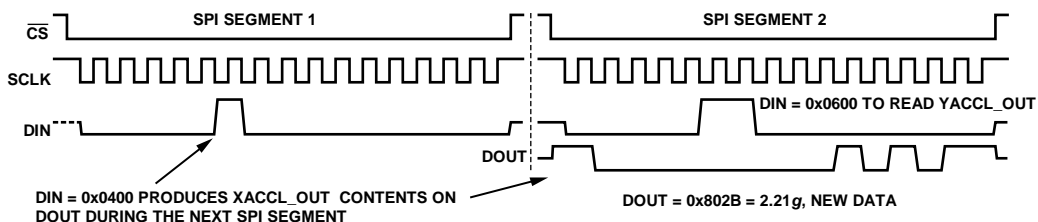

Figure 17. Example SPI Read Sequence

User registers govern all data collection and configuration. Table 7 provides a memory map that includes all user registers, along with references to bit assignment tables that follow the generic assignments in Figure 15.

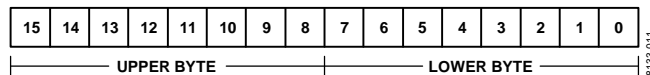

Figure 15. Generic Register Bit Assignments

### SPI Write Commands

Master processors write to the control registers, one byte at a time, using the bit assignments shown in Figure 18. The programmable registers in Table 7 provide controls for optimizing sensor operation and for starting various automated functions. For example, set GLOB\_CMD[8] = 1 (DIN = 0xCB01) to wake up the device.

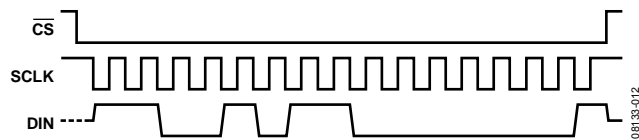

Figure 16. SPI Sequence for a Wake-Up Command (DIN = 0xCB01)

Some configurations require writing both bytes to a register, which takes two separate 16-bit sequences. See GLOB\_CMD[3] in Table 24 for backing up configuration data in nonvolatile flash memory.

### SPI Read Commands

Reading data on the SPI requires two consecutive 16-bit sequences. The first sequence transmits the read command on DIN, and the second sequence receives the resulting data from DOUT. The 7-bit register address can represent either the upper or lower byte address for the target register. For example, DIN can be either 0x0200 or 0x0300 when reading the SUPPLY\_OUT register. The SPI operates in full duplex mode, which means that the master processor can read the output data from DOUT while using the same SCLK pulses to transmit a new command on DIN. In Figure 17, the second SPI segment sets up the device to read YACCL\_OUT on the following SPI segment (not shown).

## MEMORY MAP

Note that all registers are two bytes. All unused memory locations are reserved for future use.

Table 7. User Register Memory Map

Register Name	Read/Write	Flash Backup	Register Address <sup>1</sup>	Default	Function	Bit Assignments
FLASH_CNT	R	Yes	0x00	N/A	Flash memory write count	N/A
SUPPLY_OUT	R	No	0x02	N/A	Output, power supply	See Table 10
XACCL_OUT	R	No	0x04	N/A	Output, x-axis accelerometer	See Table 9
YACCL_OUT	R	No	0x06	N/A	Output, y-axis accelerometer	See Table 9
ZACCL_OUT	R	No	0x08	N/A	Output, z-axis accelerometer	See Table 9
AUX_ADC	R	No	0x0A	N/A	Output, auxiliary ADC input	See Table 8
TEMP_OUT	R	No	0x0C	N/A	Output, temperature	See Table 11
XPEAK_OUT	R	No	0x0E	N/A	Output, x-axis acceleration peak	See Table 9
YPEAK_OUT	R	No	0x10	N/A	Output, y-axis acceleration peak	See Table 9
ZPEAK_OUT	R	No	0x12	N/A	Output, z-axis acceleration peak	See Table 9
XYZPEAK_OUT	R	No	0x14	N/A	Output, sum-of-squares acceleration peak	See Table 8
CAPT_BUF1	R		0x16	N/A	Output, Capture Buffer 1, X and Y acceleration	See Table 18
CAPT_BUF2	R		0x18	N/A	Output, Capture Buffer 2, Z acceleration	See Table 19
DIAG_STAT	R		0x1A	0x0000	Diagnostic, error flags	See Table 28
EVNT_CNTR	R		0x1C	0x0000	Diagnostic, event counter	See Table 21
CHK_SUM	R	Yes	0x1E	N/A	Diagnostic, check sum value from firmware test	See Table 34
XACCL_OFF	R/W	Yes	0x20	0x0000	Calibration, x-axis acceleration offset adjustment	See Table 27
YACCL_OFF	R/W	Yes	0x22	0x0000	Calibration, y-axis acceleration offset adjustment	See Table 27
ZACCL_OFF	R/W	Yes	0x24	0x0000	Calibration, z-axis acceleration offset adjustment	See Table 27
CLK_TIME	R/W	Yes	0x2E	0x0000	Clock, hour and minute	See Table 29
CLK_DATE	R/W	Yes	0x30	0x0000	Clock, month and day	See Table 30
CLK_YEAR	R/W	Yes	0x32	0x0000	Clock, year	See Table 31
WAKE_TIME	R/W	Yes	0x34	0x0000	Wake-up setting, hour and minute	See Table 32
WAKE_DATE	R/W	Yes	0x36	0x0000	Wake-up setting, month and day	See Table 33
ALM_MAG1	R/W	Yes	0x38	0x9000	Alarm 1 amplitude threshold	See Table 13
ALM_MAG2	R/W	Yes	0x3A	0x9000	Alarm 2 amplitude threshold	See Table 13
ALM_CTRL	R/W	Yes	0x3C	0x0000	Alarm control	See Table 12
XTRIG_CTRL	R/W	Yes	0x3E	0x0000	Capture, external trigger control	See Table 15
CAPT_PNTR	R/W	Yes	0x40	0x0000	Capture, address pointer	See Table 20
CAPT_CTRL	R/W	Yes	0x42	0x0022	Capture, configuration and control	See Table 17
GPIO_CTRL	R/W	No	0x44	0x0000	General-purpose digital input/output control	See Table 26
MSC_CTRL	R/W	No	0x46	0x0006	Miscellaneous control	See Table 25
SMPL_PRD	R/W	Yes	0x48	0x001F	Internal sample period (rate) control	See Table 23
GLOB_CMD	W	Yes	0x4A	N/A	System command	See Table 24

<sup>1</sup> Each register contains two bytes. The address of the lower byte is displayed. The address of the upper byte is equal to the address of the lower byte plus 1.

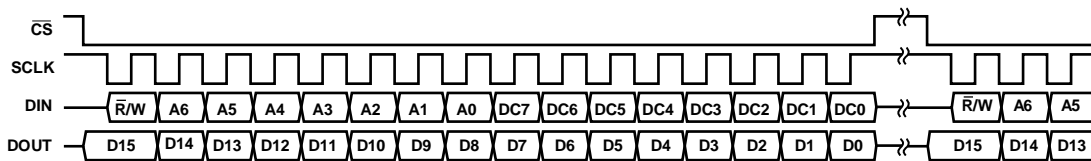

**NOTES**

1. DOUT BITS ARE BASED ON THE PREVIOUS 16-BIT SEQUENCE, WHEN  $\bar{R}/W = 0$ .

Figure 18. SPI Communication Bit Sequence

08133-014

**OUTPUT DATA REGISTERS**

Each output data register uses the bit assignments shown in Figure 19. The ND flag indicates that unread data resides in the register. This flag clears and returns to 0 after reading the register. It returns to 1 after the next internal sample updates the register with new data. When the data-ready function (the DIO1 and DIO2 pins and the MSC\_CTRL register; see Table 25) drives data collection, the ND bit is always high and does not require validation. The EA flag indicates that one of the error flags in the DIAG\_STAT register (see Table 28) is active (true).

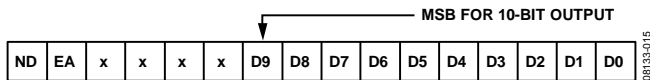

Figure 19. Output Register Bit Assignments

**Table 8. Output Data Register Formats**

Register	Bits	Format	Scale
SUPPLY_OUT	10	Binary, 0 V = 0x0000	4.88 mV
XACCL_OUT	10	Twos complement	51.4 mg
YACCL_OUT	10	Twos complement	51.4 mg
ZACCL_OUT	10	Twos complement	51.4 mg
AUX_ADC	10	Binary, 0 V = 0x0000	V <sub>DD</sub> /1024
TEMP_OUT	10	Binary, 25°C = 0x0133	0.244°C
XPEAK_OUT <sup>1</sup>	10	Twos complement	51.4 mg
YPEAK_OUT <sup>1</sup>	10	Twos complement	51.4 mg
ZPEAK_OUT <sup>1</sup>	10	Twos complement	51.4 mg
XYZPEAK_OUT <sup>2</sup>	12	Binary, 0 g <sup>2</sup> = 0x0000	0.676 g <sup>2</sup>

<sup>1</sup> Function requires MSC\_CTRL[14] = 1.

<sup>2</sup> Function requires MSC\_CTRL[15] = 1.

**Processing Sensor Data**

Processing sensor data starts with reading the appropriate output data register using the SPI. For example, use DIN = 0x0E00 to read the XPEAK\_OUT register. Use the ND and EA bits to validate new data and normal operating status, if necessary. Then mask off all of the nondata bits and calculate the data, using the format and scale information shown in Table 8. For example, XACCL\_OUT[9:0] and XYZPEAK\_OUT[11:0] contain all relevant data for their function. Table 9, Table 10, and Table 11 provide output code examples for each output register.

**Table 9. Accelerometer Data Output Format<sup>1</sup>**

Binary	Hex	Codes	Acceleration
01 0011 0111	0x137	+311	+16 g
...	...	...	...
00 0000 0010	0x002	+2	+102.8 mg
00 0000 0001	0x001	+1	+51.4 mg
00 0000 0000	0x000	0	0
11 1111 1111	0x3FF	-1	-51.4 mg
11 1111 1110	0x3FE	-2	-102.8 mg
...	...	...	...
10 1100 1001	0x2C9	-311	-16 g

<sup>1</sup> The XACCL\_OUT register is located at Address 0x05[15:8] and Address 0x04[7:0]. The YACCL\_OUT register is located at Address 0x07[15:8] and Address 0x06[7:0]. The ZACCL\_OUT register is located at Address 0x09[15:8] and Address 0x08[7:0]. The XPEAK\_OUT register is located at Address 0x0F[15:8] and Address 0x0E[7:0]. The YPEAK\_OUT register is located at Address 0x11[15:8] and Address 0x10[7:0]. The ZPEAK\_OUT register is located at Address 0x13[15:8] and Address 0x12[7:0].

When MSC\_CTRL[14] = 1, the XPEAK\_OUT, YPEAK\_OUT, and ZPEAK\_OUT registers track the peak acceleration in each acceleration output register. When MSC\_CTRL[15] = 1, use the following equation to calculate the root mean square (rms) of all three peak registers, where 1 LSB = 0.822 g:

$$XYZ_{rms} = \sqrt{XYZPEAK\_OUT}$$

Set GLOB\_CMD[5] = 1 to reset these registers to 0x0000.

**Table 10. Power Supply Data Output Format<sup>1</sup>**

Binary	Hex	Codes	Power Supply (V)
10 1110 0010	0x2E2	738	3.6
...	...	...	...
10 1010 0101	0x2A5	677	3.30488
10 1010 0100	0x2A4	676	3.3
10 1010 0011	0x2A3	675	3.29502
...	...	...	...
01 1110 1100	0x1EC	492	2.4

<sup>1</sup> The SUPPLY\_OUT register is located at Address 0x03[15:8] and Address 0x02[7:0].

**Table 11. Temperature Data Output Format<sup>1</sup>**

Binary	Hex	Codes	Temperature (°C)
10 0010 1001	0x229	553	+85°C
...	...	...	...
01 0011 0100	0x134	308	+25.244°C
01 0011 0011	0x133	307	+25°C
01 0011 0010	0x132	306	+24.756°C
...	...	...	...
00 0010 1001	0x029	41	-40°C

<sup>1</sup> The TEMP\_OUT register is located at Address 0x0D[15:8] and Address 0x0C[7:0].

## EVENT RECORDER

The ADIS16240 provides a  $3 \times 8192$  (8-bit) buffer memory for reading transient acceleration data on all three axes (x, y, and z). There are a number of user controls for tailoring the event recorder for optimal system-level operation. Alarm 1 and Alarm 2 provide internal and external trigger options for starting a data capture sequence.

### Internal Trigger Setup

Select the trigger data source for Alarm 1 and Alarm 2 using ALM\_CTRL[15:8] (see Table 12). The ALM\_MAG1 and ALM\_MAG2 registers contain threshold magnitude and direction settings for Alarm 1 and Alarm 2, respectively. The format for the data bits in these registers matches the trigger data source, which is set using ALM\_CTRL[15:8]. For example, if ALM\_CTRL[15:12] equals 0010, then the format matches that of XACCL\_OUT: 10-bit, twos complement, with 1 LSB = 51.4 mg of acceleration.

**Table 12. ALM\_CTRL Register Bit Descriptions<sup>1</sup>**

Bit	Description (Default = 0x0000)
[15:12]	Alarm 2 source selection 0000 = disabled 0001 = power supply voltage (SUPPLY_OUT) 0010 = x acceleration (XACCL_OUT) 0011 = y acceleration (YACCL_OUT) 0100 = z acceleration (ZACCL_OUT) 0101 = auxiliary ADC voltage (AUX_ADC) 0110 = temperature (TEMP_OUT) 0111 = XYZ peak acceleration (XYZPEAK_OUT) 1000 = external trigger
[11:8]	Alarm 1 source selection (same as Alarm 2)
[7:6]	Unused
5	Alarm 2 capture trigger: 1 = enabled, 0 = disabled
4	Alarm 1 capture trigger: 1 = enabled, 0 = disabled
3	Unused
2	Alarm indicator enable: 1 = enabled, 0 = disabled
1	Alarm indicator polarity: 1 = positive, 0 = negative
0	Alarm indicator pin: 1 = DIO2, 0 = DIO1

<sup>1</sup> The ALM\_CTRL register is located at Address 0x3D[15:8] and Address 0x3C[7:0].

**Table 13. ALM\_MAG1, ALM\_MAG2 Register Bit Descriptions<sup>1</sup>**

Bit	Description (Default = 0x9000)
15	Threshold direction 1 = active for output greater than alarm magnitude 0 = inactive for output less than alarm magnitude
14	Unused
[13:0]	Trigger threshold; bit format matches that of the register selected by ALM_CTRL[15:8] but is unsigned.

<sup>1</sup> The ALM\_MAG1 register is located at Address 0x39[15:8] and Address 0x38[7:0]. The ALM\_MAG2 register is located at Address 0x3B[15:8] and Address 0x3A[7:0].

**Table 14. Internal Trigger Setup Example**

DIN	Description
0xBD44	Set Alarm 1 and Alarm 2 to ZACCL_OUT
0xB980, 0xB832	Set Alarm 1 to trigger on a measured acceleration that has a magnitude of $>2.57 g$
0xBB00, 0xBA0A	Set Alarm 2 to trigger on a measured acceleration that has a magnitude of $<0.5 g$
0xBC37	Activate Alarm 1 and Alarm 2 to trigger capture events, and configure DIO2 as a positive alarm indicator output.

### External Trigger Setup

ALM\_CTRL[15:8] and XTRIG\_CTRL (see Table 15) provide all of the settings needed to govern the use of the comparator pins (CMP1, CMP2) as external trigger inputs.

**Table 15. XTRIG\_CTRL Register Bit Descriptions<sup>1</sup>**

Bit	Description (Default = 0x0000)
[15:8]	Unused
7	External Trigger 1 direction: 0 = $<$ , 1 = $>$
6	External Trigger 2 direction: 0 = $<$ , 1 = $>$
5	External Trigger 1 enable: 1 = enabled, 0 = disabled
4	External Trigger 2 enable: 1 = enabled, 0 = disabled
[3:0]	External trigger-level setting (TL), binary format Note that trigger threshold = $TL \times \text{supply}/24$

<sup>1</sup> The XTRIG\_CTRL register is located at Address 0x3F[15:8] and Address 0x3E[7:0].

**Table 16. External Trigger Setup Example**

DIN	Description
0xBD80	Set Alarm 2 to an external trigger (ALM_CTRL)
0xBE1C	Activate and set CMP2 to trigger on signals that are greater than one-half of the supply voltage (XTRIG_CTRL)
0xBC20	Activate Alarm 2 to trigger data capture (ALM_CTRL)

If the device is in standby mode, an external trigger on CMD1 or CMD2 awakens the device and initiates an event capture. The first sample is taken  $0.2 \text{ ms} + \text{sample period}$  (SMPL\_PRD[7:0]) after the trigger edge.

### Buffer Memory Configuration

CAPT\_CTRL (see Table 17) manages the buffer memory for the event recorder using two programmable controls: event length and pretrigger length.

**Table 17. CAPT\_CTRL Register Bit Descriptions<sup>1</sup>**

Bit	Description (Default = 0x0022)
[15:8]	Unused
[7:4]	Pretrigger length control factor (P), binary format
3	Unused
[2:0]	Event length control factor (T), binary format

<sup>1</sup> The CAPT\_CTRL register is located at Address 0x43[15:8] and Address 0x42[7:0].

The event length ( $N_L$ ) also determines the number of events ( $N_E$ ) that the buffer can store at one time.

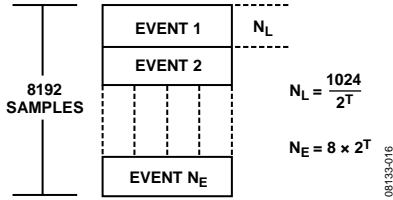

Figure 20. Event Storage in Buffer Memory

For example, if CAPT\_CTRL[2:0] = 100, then T = 4, which organizes the buffer memory into 128 events of 64 samples each.

**Event Organization**

Each event contains a header, pretrigger data, and posttrigger data, as shown in Figure 21. The event header provides information about the conditions that occur when the capture takes place. CAPT\_CTRL[7:4] sets the number of pretrigger samples in each event. If N\_PRE is negative, there is no pretrigger data and the first sample after the trigger follows the header.

$$N_{PRE} = \frac{N_L}{16} - 6$$

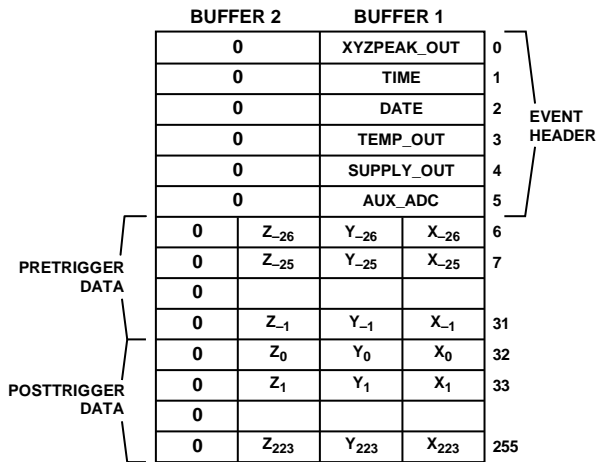

Figure 21. Default Event Organization

**Reading Event Data**

The CAPT\_BUF1, CAPT\_BUF2, and CAPT\_PNTR registers manage user access to data in the capture buffer (see Table 18, Table 19, and Table 20). The address pointer, CAPT\_PNTR, determines which capture memory location loads into the capture buffer registers. It increments automatically with every CAPT\_BUF2 read. The most efficient method for reading the entire buffer memory space is to alternate between the CAPT\_BUF1 (DIN = 0x9600) and CAPT\_BUF2 (DIN = 0x9800) read commands. When alternating the read sequences in this manner, the CAP\_PNTR increments automatically and optimizes SPI processing resources. Writing to the CAPT\_PNTR register provides access to individual locations in the capture. For example, writing 0x0138 (DIN = 0xC038, DIN = 0xC101) to the CAPT\_PNTR register causes the 311<sup>th</sup> sample in each buffer memory to load into the CAP\_BUF1 and CAPT\_BUF2 locations (see Figure 22).

Table 18. CAPT\_BUF1 Register Bit Descriptions<sup>1</sup>

Bit	Description	Format
[15:8]	Y-axis acceleration	Twos complement, 205.7 mg/LSB
[7:0]	X-axis acceleration	

<sup>1</sup> The CAPT\_BUF1 register is located at Address 0x17[15:8] and Address 0x16[7:0].

Table 19. CAPT\_BUF2 Register Bit Descriptions<sup>1</sup>

Bit	Description	Format
[15:8]	Unused	Twos complement, 205.7 mg/LSB
[7:0]	Z-axis acceleration	

<sup>1</sup> The CAPT\_BUF2 register is located at Address 0x19[15:8] and Address 0x18[7:0].

Table 20. CAPT\_PNTR Register Bit Descriptions<sup>1</sup>

Bit	Description
[15:13]	Unused
[7:0]	Buffer address that loads into CAPT_BUF1, CAPT_BUF2

<sup>1</sup> The CAPT\_PNTR register is located at Address 0x41[15:8] and Address 0x40[7:0].

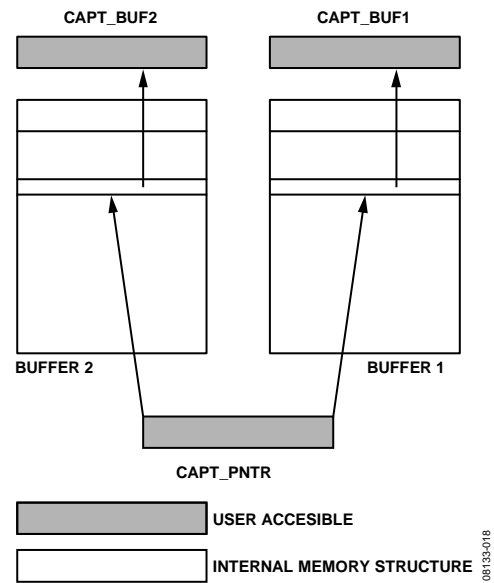

Figure 22. Capture Buffer Data Flow Diagram

The EVNT\_CNTR register (see Table 21) provides a running count for the number of triggers (internal and external) that occur after a buffer clear and/or reset. If this number is greater than the number of events, this indicates that the device has experienced trigger events that it could not capture because its capture buffer is full. The EVNT\_CNTR returns to 0x0000 after a buffer clear (GLOB\_CMD[6] = 1 by DIN = 0xCA40), or a factory reset (GLOB\_CMD[1] = 1 by DIN = 0xCA02). After a power cycle or software reset command, the EVNT\_CNTR contains the number of events stored in the buffer memory.

Table 21. EVNT\_CNTR Register Bit Descriptions<sup>1</sup>

Bit	Description
[15:0]	Binary event counter

<sup>1</sup> The EVNT\_CNTR register is located at Address 0x1D[15:8] and Address 0x1C[7:0].



## Transient Behavior During Capture

During capture events, the device consumes an increased amount of current for a short period. Following a capture event, sampling suspends and the SPI commands are ignored by the sensor for the pause times that are listed in Table 22.

**Table 22. Postcapture Operation Pause Times**

Event Length (Samples)	Pause Time (ms)
≤64	2
128	4
256	8
512	16
1024	33

## OPERATIONAL CONTROL

### Internal Sample Rate

The SMPL\_PRD register (see Table 23) provides a user control for sample rate adjustment, using the following equation:

$$f_s = \frac{32768}{(N_{SR} + 1)}$$

For example, set SMPL\_PRD[7:0] = 0x07 (DIN = 0xC807) to configure the ADIS16240 to operate at its maximum sample rate of 4096 SPS. Note that the sample rate affects power dissipation and peak resolution during event capture.

**Table 23. SMPL\_PRD Register Bit Descriptions<sup>1</sup>**

Bit	Description (Default = 0x001F)
[15:0]	Sample rate scale factor, binary format (N <sub>SR</sub> )

<sup>1</sup> The SMPL\_PRD register is located at Address 0x49[15:8] and Address 0x48[7:0].

### Global Commands

For convenience, the GLOB\_CMD register (see Table 24) provides an array of single-write commands. Setting the assigned bit to 1 activates each function, right after the 16<sup>th</sup> SCLK in the SPI communication sequence. When the function completes, the bit restores itself to 0. All commands in the GLOB\_CMD register require the power supply to be within normal limits for the execution times listed in Table 24. The execution times reflect the factory default configuration, where applicable, and describe the time required to return to normal operation. For example, set GLOB\_CMD[2] = 1 (DIN = 0xCA04) to place the part in standby mode. Set GLOB\_CMD[8] = 1 (DIN = 0xCB01) to wake up the device and return to normal operation.

### Input/Output Lines

The ADIS16240 provides two general-purpose digital input/output lines that offer several functions. When using the factory-default configuration, MSC\_CTRL[2:0] establishes DIO1 as a positive data-ready output. Change MSC\_CTRL[2:0] to 100 (DIN = 0xC604) to make DIO1 a negative data-ready output signal. ALM\_CTRL[2:0] offers a control for setting one of the digital signals as an alarm indicator. For example, set ALM\_CTRL[2:0] = 110 (DIN = 0xBC06) to set DIO1 as a positive alarm indicator output signal. When configured as general-

purpose lines, the GPIO\_CTRL register configures DIO1 and DIO2. For example, set GPIO\_CTRL = 0x0103 (DIN = 0xC403, then 0xC501) to set DIO1 and DIO2 as outputs, with DIO1 in a 1 state and DIO2 in a 0 state. In the event of competing assignments, the order of precedence is MSC\_CTRL, ALM\_CTRL, and GPIO\_CTRL.

**Table 24. GLOB\_CMD Register Bit Descriptions<sup>1</sup>**

Bit	Description	Execution Time <sup>2</sup>
[15:9]	Unused	N/A
8	Wake up from standby mode	0.2 ms
7	Software reset	32 ms
6	Clear capture buffer flash memory	350 ms
5	Clear peak registers	N/A
4	Clear DIAG_STAT register	N/A
3	Save configuration to flash	24 ms
2	Start standby mode for low power	N/A
1	Restore factory-default settings	350 ms
0	Auto-null	N/A

<sup>1</sup> The GLOB\_CMD register is located at Address 0x4B[15:8] and Address 0x4A[7:0].

<sup>2</sup> SPI processing and data sampling suspend for the indicated times.

**Table 25. MSC\_CTRL Register Bit Descriptions<sup>1</sup>**

Bit	Description (Default = 0x0006)
15	Enables sum-of-squares output (XYZPEAK_OUT)
14	Enables peak tracking output (XPEAK_OUT, YPEAK_OUT, and ZPEAK_OUT)
[13:10]	Unused
9	No self-test on startup when set to 1
8	Self-test enable: 1 = apply electrostatic force, 0 = disabled
[7:3]	Unused
2	Data-ready enable: 1 = enabled, 0 = disabled
1	Data-ready polarity: 1 = active high, 0 = active low
0	Data-ready line selection: 1 = DIO2, 0 = DIO1

<sup>1</sup> The MSC\_CTRL register is located at Address 0x47[15:8] and Address 0x46[7:0].

**Table 26. GPIO\_CTRL Register Bit Descriptions<sup>1</sup>**

Bit	Description (Default = 0x0000)
[15:10]	Unused
9	General-Purpose I/O Line 2 data level
8	General-Purpose I/O Line 1 data level
[7:2]	Unused
1	General-Purpose I/O Line 2, data direction control: 1 = output, 0 = input
0	General-Purpose I/O Line 1, data direction control: 1 = output, 0 = input

<sup>1</sup> The GPIO\_CTRL register is located at Address 0x45[15:8] and Address 0x44[7:0].

### Offset Adjustment

The XACCL\_OUT, YACCL\_OFF, and ZACCL\_OFF registers add to the sensor outputs and provide a convenient offset adjustment function for each accelerometer output. For example, writing 0x0A to YACCL\_OUT[7:0] (DIN = 0xA20A) results in a 514 mg offset adjustment for the YACCL\_OUT output data.

**Table 27. XACCL\_OFF, YACCL\_OFF, ZACCL\_OFF<sup>1</sup>**

Bit	Description (Default = 0x0000)
[15:10]	Unused
[9:0]	Offset, twos complement, 51.4 mg/LSB

<sup>1</sup> The XACCL\_OFF register is located at Address 0x21[15:8] and Address 0x20[7:0].  
 The YACCL\_OFF register is located at Address 0x23[15:8] and Address 0x22[7:0].  
 The ZACCL\_OFF register is located at Address 0x25[15:8] and Address 0x24[7:0].

**Diagnostics**

For all of the error flags in the DIAG\_STAT register (see Table 28), a 1 identifies an error condition, and a 0 signals normal operation. All of the flags return to 0 after reading DIAG\_STAT. If the power supply is still out of range during the next sample cycle, DIAG\_STAT[0] and DIAG\_STAT[1] return to 1. DIAG\_STAT[9:8] provide flags to check for the alarms with respect to the conditions in the ALM\_CTRL and ALM\_MAGx registers. DIAG\_STAT[6] contains the internal memory checksum result. If the sum of the firmware program memory does not match the expected value, this flag reports a 1. The SPI communication flag (DIAG\_STAT[3]) changes to 1 when the number of SCLK pulses during a SPI transfer is not a multiple of 16 when CS goes high.

**Table 28. DIAG\_STAT Register Bit Descriptions<sup>1</sup>**

Bit	Description (Default = 0x0000)
[15:10]	Unused
9	Alarm 2 status: 1 = alarm active, 0 = alarm inactive
8	Alarm 1 status: 1 = alarm active, 0 = alarm inactive
7	Capture buffer full: 1 = capture buffer is full
6	Flash test, checksum flag: 1 = mismatch, 0 = match
5	Power-on, self-test flag: 1 = failure, 0 = pass
4	Power-on self-test: 1 = in-progress, 0 = complete
3	SPI communications failure: 1 = error, 0 = normal
2	Flash update failure: 1 = failure, 0 = pass
1	Power supply above 3.625 V: 1 = above, 0 = below
0	Power supply below 2.225 V: 1 = below, 0 = above

<sup>1</sup> The DIAG\_STAT register is located at Address 0x1B[15:8] and Address 0x1A[7:0].

**Clock**

The CLK\_TIME, CLK\_DATE, and CLK\_YEAR registers provide an internal clock that enables a time entry into the event header and for user access. If CLK\_TIME = 0x2231, the time is 22:31, or 10:31 p.m. The CLK\_DATE and CLK\_YEAR registers follow a similar binary-coded, decimal format.

**Table 29. CLK\_TIME Register Bit Descriptions<sup>1</sup>**

Bit	Description
[15:14]	Unused
[13:12]	Hours, 10s digit
[11:8]	Hours, 1s digit
7	Unused
[6:4]	Minutes, 10s digit
[3:0]	Minutes, 1s digit

<sup>1</sup> The CLK\_TIME register is located at Address 0x2F[15:8] and Address 0x2E[7:0].

**Table 30. CLK\_DATE Register Bit Descriptions<sup>1</sup>**

Bit	Description (Default = 0x0000)
[15:13]	Unused
12	Month, 10s digit
[11:8]	Month, 1s digit
[7:6]	Unused
[5:4]	Day, 10s digit
[3:0]	Day, 1s digit

<sup>1</sup> The CLK\_DATE register is located at Address 0x31[15:8] and Address 0x30[7:0].

**Table 31. CLK\_YEAR Register Bit Descriptions<sup>1</sup>**

Bit	Description (Default = 0x0000)
[15:8]	Unused
[7:4]	Year, 10s digit
[3:0]	Year, 1s digit

<sup>1</sup> The CLK\_YEAR register is located at Address 0x33[15:8] and Address 0x32[7:0].

The WAKE\_TIME and WAKE\_DATE registers enable users to program a specific time for the ADIS16240 to exit standby mode. Enable this function by writing the wake-up time and date to these registers.

**Table 32. WAKE\_TIME Register Bit Descriptions<sup>1</sup>**

Bit	Description (Default = 0x0000)
15	Wake time enable (1 = enabled, 0 = disabled)
14	Unused
[13:12]	Hours, 10s digit
[11:8]	Hours, 1s digit
7	Unused
[6:4]	Minutes, 10s digit
[3:0]	Minutes, 1s digit

<sup>1</sup> The WAKE\_TIME register is located at Address 0x35[15:8] and Address 0x34[7:0].

**Table 33. WAKE\_DATE Register Bit Descriptions<sup>1</sup>**

Bit	Description (Default = 0x0000)
[15:14]	Unused
[13:12]	Month, 10s digit
[11:8]	Month, 1s digit
[7:6]	Unused
[5:4]	Day, 10s digit
[3:0]	Day, 1s digit

<sup>1</sup> The WAKE\_DATE register is located at Address 0x37[15:8] and Address 0x36[7:0].

**Checksum**

**Table 34. CHK\_SUM Register Bit Descriptions<sup>1</sup>**

Bit	Description
[15:0]	Sum of memory locations used to verify code integrity

<sup>1</sup> The CHK\_SUM register is located at Address 0x1F[15:8] and Address 0x1E[7:0].

# OUTLINE DIMENSIONS

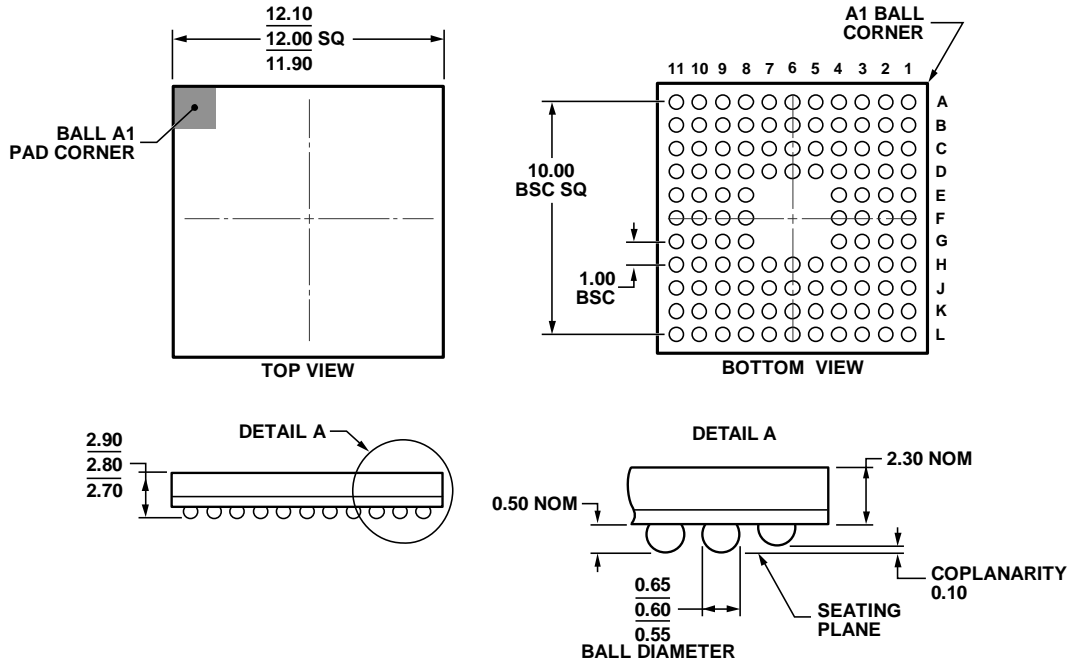

010909-A

Figure 23. 112-Ball Plastic Ball Grid Array [PBGA] (B-112-1)  
Dimensions shown in millimeters

## ORDERING GUIDE

Model	Temperature Range	Package Description	Package Option
ADIS16240ABCZ <sup>1</sup>	-40°C to +85°C	112-Ball Plastic Ball Grid Array [PBGA]	B-112-1
ADIS16240/PCBZ <sup>1</sup>		Evaluation Board	

<sup>1</sup> Z = RoHS Compliant Part.