

Low Voltage Precision Air-Core Tach/Speedo Driver

The CS4121 is specifically designed for use with air-core meter movements. The IC provides all the functions necessary for an analog tachometer or speedometer. The CS4121 takes a speed sensor input and generates sine and cosine related output signals to differentially drive an air-core meter.

Many enhancements have been added over industry standard tachometer drivers such as the CS289 or LM1819. The output utilizes differential drivers which eliminates the need for a Zener reference and offers more torque. The device withstands 60 V transients which decreases the protection circuitry required. The device is also more precise than existing devices allowing for fewer trims and for use in a speedometer.

The CS4121 is compatible with the CS8190, and provides higher accuracy at a lower supply voltage (8.0 V min. as opposed to 8.5 V). It is functionally operational to 6.5 V.

Features

- Pb-Free Package is Available*
- Direct Sensor Input
- High Torque Output
- Low Pointer Flutter
- High Input Impedance
- Overvoltage Protection
- Accurate to 8.0 V Functional to 6.5 V (typ)
- Internally Fused Leads in SO-20 Package and DIP-16

ABSOLUTE MAXIMUM RATINGS

Rating	Value	Unit
Supply Voltage, V_{CC}		
< 100 ms Pulse Transient	60	V
Continuous	24	V
Operating Temperature (T_J)	-40 to +105	°C
Storage Temperature	-40 to +165	°C
Junction Temperature	-40 to +150	°C
ESD (Human Body Model)	4.0	kV
Lead Temperature Soldering:		
Wave Solder (through hole styles only) (Note 1)	260 peak	°C
Reflow: (SMD styles only) (Note 2)	230 peak	°C

Maximum ratings are those values beyond which device damage can occur. Maximum ratings applied to the device are individual stress limit values (not normal operating conditions) and are not valid simultaneously. If these limits are exceeded, device functional operation is not implied, damage may occur and reliability may be affected.

1. 10 seconds maximum.
2. 60 second maximum above 183°C.

*For additional information on our Pb-Free strategy and soldering details, please download the ON Semiconductor Soldering and Mounting Techniques Reference Manual, SOLDERRM/D.



ON Semiconductor®

<http://onsemi.com>

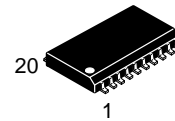

SO-20L
DWF SUFFIX
CASE 751D

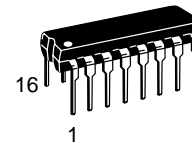

DIP-16
NF SUFFIX
CASE 648

ORDERING INFORMATION

Device	Package	Shipping†
CS4121EDWF20	SO-20L	37 Units/Rail
CS4121EDWF20G	SO-20L (Pb-Free)	37 Units/Rail
CS4121EDWFR20	SO-20L	1000 Tape&Reel
CS4121ENF16	DIP-16	25 Units/Rail

†For information on tape and reel specifications, including part orientation and tape sizes, please refer to our Tape and Reel Packaging Specifications Brochure, BRD8011/D.

DEVICE MARKING INFORMATION

See specific marking information and pin connection information on page 4 of this data sheet.

CS4121

[查询"CS4121EDWF20G"供应商](#)

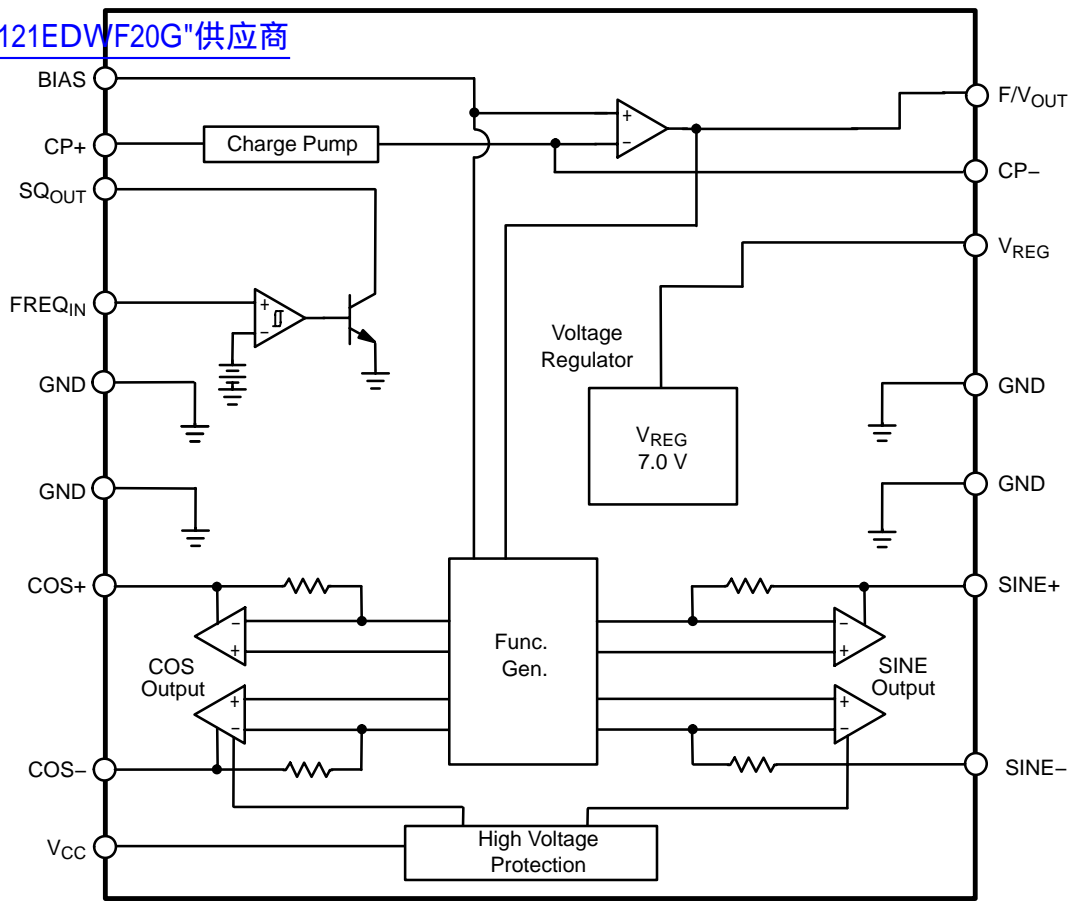

Figure 1. Block Diagram

CS4121

ELECTRICAL CHARACTERISTICS ($-40^{\circ}\text{C} \leq T_A \leq 85^{\circ}\text{C}$, $8.0\text{ V} \leq V_{CC} \leq 16\text{ V}$, unless otherwise specified.)

Characteristic	Test Conditions	Min	Typ	Max	Unit
----------------	-----------------	-----	-----	-----	------

Supply Voltage Section

I_{CC} Supply Current	$V_{CC} = 16\text{ V}$, -40°C , No Load	-	50	125	mA
V_{CC} Normal Operation Range	-	8.0	13.1	16	V

Input Comparator Section

Positive Input Threshold	-	1.0	2.0	3.0	V
Input Hysteresis	-	200	500	-	mV
Input Bias Current (Note 4)	$0\text{ V} \leq V_{IN} \leq 8.0\text{ V}$	-	-10	-80	μA
Input Frequency Range	-	0	-	20	kHz
Input Voltage Range	in series with $1.0\text{ k}\Omega$	-1.0	-	V_{CC}	V
Output V_{SAT}	$I_{CC} = 10\text{ mA}$	0	0.15	0.40	V
Output Leakage	$V_{CC} = 7.0\text{ V}$	-	-	10	μA
Logic 0 Input Voltage	-	1.0	-	-	V

Voltage Regulator Section

Output Voltage	-	6.25	7.00	7.50	V
Output Load Current	-	-	-	10	mA
Output Load Regulation	0 to 10 mA	-	10	50	mV
Output Line Regulation	$8.0\text{ V} \leq V_{CC} \leq 16\text{ V}$	-	20	150	mV
Power Supply Rejection	$V_{CC} = 13.1\text{ V}$, $1.0\text{ V}_{P/P}$, 1.0 kHz	34	46	-	dB

Charge Pump Section

Inverting Input Voltage	-	1.5	2.0	2.5	V
Input Bias Current	-	-	40	150	nA
V_{BIAS} Input Voltage	-	1.5	2.0	2.5	V
Non Invert. Input Voltage	$I_{IN} = 1.0\text{ mA}$	-	0.7	1.1	V
Linearity (Note 3)	@ 0, 87.5, 175, 262.5, + 350 Hz	-0.10	0.28	+0.70	%
F/ V_{OUT} Gain	@ 350 Hz, $C_{CP} = 0.0033\text{ }\mu\text{F}$, $R_T = 243\text{ k}\Omega$	7.0	10	13	mV/Hz
Norton Gain, Positive	$I_{IN} = 15\text{ }\mu\text{A}$	0.9	1.0	1.1	I/I
Norton Gain, Negative	$I_{IN} = 15\text{ }\mu\text{A}$	0.9	1.0	1.1	I/I

Function Generator Section ($-40^{\circ}\text{C} \leq T_A \leq 85^{\circ}\text{C}$, $V_{CC} = 13.1\text{ V}$ unless otherwise noted.)

Differential Drive Voltage, ($V_{COS+} - V_{COS-}$)	$8.0\text{ V} \leq V_{CC} \leq 16\text{ V}$, $\theta = 0^{\circ}$	5.5	6.5	7.5	V
Differential Drive Voltage, ($V_{SIN+} - V_{SIN-}$)	$8.0\text{ V} \leq V_{CC} \leq 16\text{ V}$, $\theta = 90^{\circ}$	5.5	6.5	7.5	V
Differential Drive Voltage, ($V_{COS+} - V_{COS-}$)	$8.0\text{ V} \leq V_{CC} \leq 16\text{ V}$, $\theta = 180^{\circ}$	-7.5	-6.5	-5.5	V
Differential Drive Voltage, ($V_{SIN+} - V_{SIN-}$)	$8.0\text{ V} \leq V_{CC} \leq 16\text{ V}$, $\theta = 270^{\circ}$	-7.5	-6.5	-5.5	V
Differential Drive Current	$8.0\text{ V} \leq V_{CC} \leq 16\text{ V}$, $T_A = 25^{\circ}\text{C}$	-	33	42	mA
Zero Hertz Output Angle	-	-1.5	0	1.5	deg
Function Generator Error (Note 5) Reference Figures 2, 3, 4, 5	$V_{CC} = 13.1\text{ V}$, $T_A = 25^{\circ}\text{C}$ $\theta = 0^{\circ}$ to 305°	-2.0	0	+2.0	deg
Function Generator Error	$13.1\text{ V} \leq V_{CC} \leq 16\text{ V}$, $T_A = 25^{\circ}\text{C}$	-2.5	0	+2.5	deg
Function Generator Error	$13.1\text{ V} \leq V_{CC} \leq 11\text{ V}$, $T_A = 25^{\circ}\text{C}$	-1.0	0	+1.0	deg
Function Generator Error	$13.1\text{ V} \leq V_{CC} \leq 8.0\text{ V}$, $T_A = 25^{\circ}\text{C}$	-3.0	0	+3.0	deg
Function Generator Error	$25^{\circ}\text{C} \leq T_A \leq 85^{\circ}\text{C}$	-3.0	0	+3.0	deg
Function Generator Error	$25^{\circ}\text{C} \leq T_A \leq 105^{\circ}\text{C}$	-5.5	0	+5.5	deg
Function Generator Error	$-40^{\circ}\text{C} \leq T_A \leq 25^{\circ}\text{C}$	-3.0	0	+3.0	deg
Function Generator Gain	θ vs F/ V_{OUT} , $T_A = 25^{\circ}\text{C}$	60	77	95	$^{\circ}/\text{V}$

3. Applies to % of full scale (270°).

4. Input is clamped by an internal 12 V Zener.

5. Deviation from nominal per Table 1 after calibration at 0° and 270° .

CS4121

查询CS4121EDWP200 供应商

PACKAGE PIN #		PIN SYMBOL	FUNCTION
DIP-16	SO-20L		
1	1	CP+	Positive input to charge pump.
2	2	SQ _{OUT}	Buffered square wave output signal.
3	3	FREQ _{IN}	Speed or RPM input signal.
4, 5, 12, 13	4-7, 14-17	GND	Ground Connections.
6	8	COS+	Positive cosine output signal.
7	9	COS-	Negative cosine output signal.
8	10	V _{CC}	Ignition or battery supply voltage.
9	11	BIAS	Test point or zero adjustment.
10	12	SIN-	Negative sine output signal.
11	13	SIN+	Positive sine output signal.
14	18	V _{REG}	Voltage regulator output.
15	19	F/V _{OUT}	Output voltage proportional to input signal frequency.
16	20	CP-	Negative input to charge pump.

MARKING DIAGRAM AND PIN CONNECTIONS

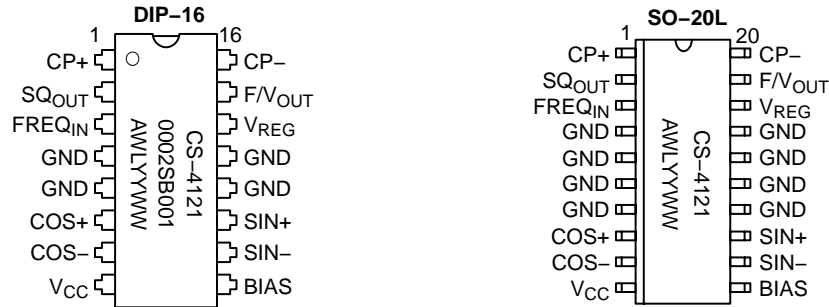

A = Assembly Location
 WL = Wafer Lot
 YY = Year
 WW = Work Week

TYPICAL PERFORMANCE CHARACTERISTICS

[查询"CS4121EDWF20G"供应商](#)

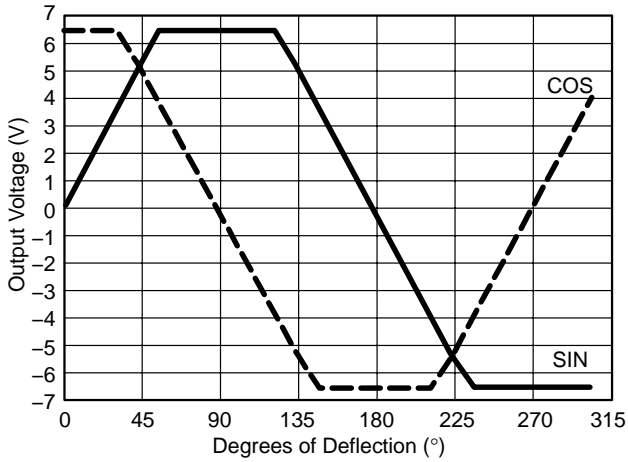

Figure 2. Function Generator Output Voltage vs. Degrees of Deflection

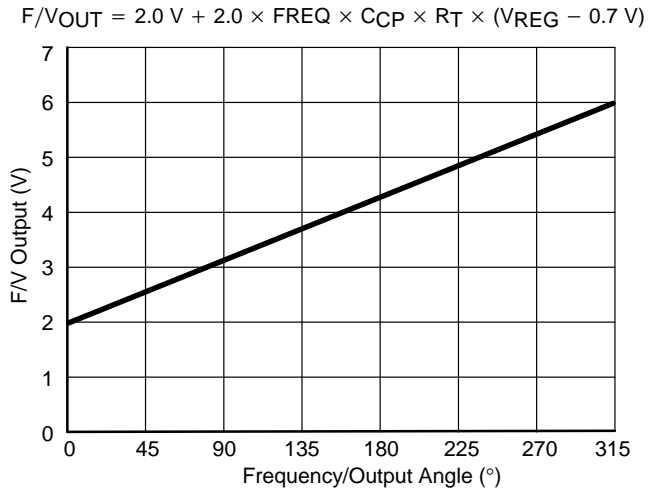

Figure 3. Charge Pump Output Voltage vs. Output Angle

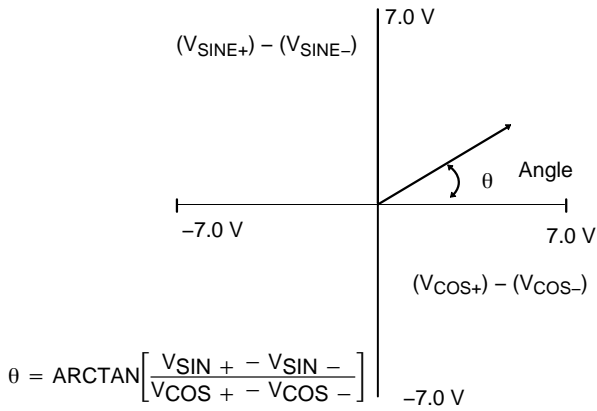

Figure 4. Output Angle in Polar Form

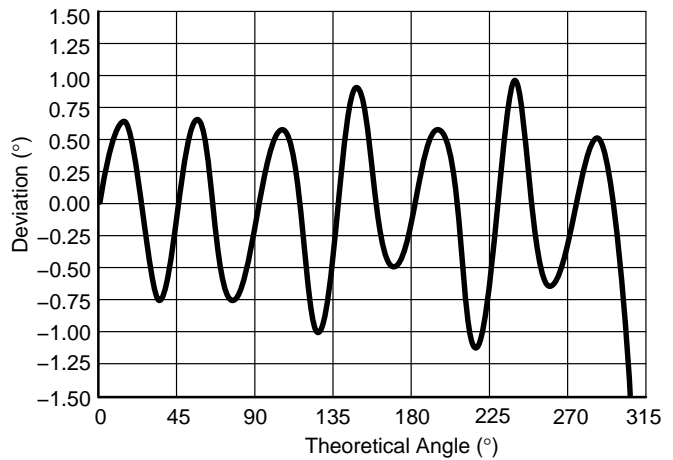

Figure 5. Nominal Output Deviation

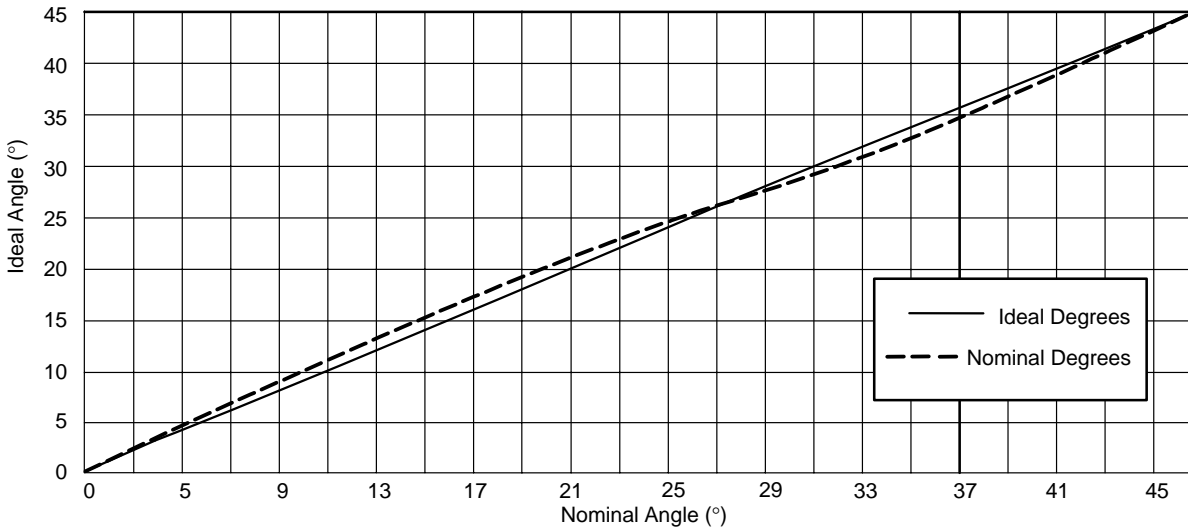

Figure 6. Nominal Angle vs. Ideal Angle (After Calibrating at 180°)

CS4121

Table 1. Function Generator Output Nominal Angle vs. Ideal Angle (After Calibrating at 270°)

Ideal θ Degrees	Nominal θ Degrees	Ideal θ Degrees	Nominal θ Degrees	Ideal θ Degrees	Nominal θ Degrees	Ideal θ Degrees	Nominal θ Degrees	Ideal θ Degrees	Nominal θ Degrees	Ideal θ Degrees	Nominal θ Degrees
0	0	17	17.98	34	33.04	75	74.00	160	159.14	245	244.63
1	1.09	18	18.96	35	34.00	80	79.16	165	164.00	250	249.14
2	2.19	19	19.92	36	35.00	85	84.53	170	169.16	255	254.00
3	3.29	20	20.86	37	36.04	90	90.00	175	174.33	260	259.16
4	4.38	21	21.79	38	37.11	95	95.47	180	180.00	265	264.53
5	5.47	22	22.71	39	38.21	100	100.84	185	185.47	270	270.00
6	6.56	23	23.61	40	39.32	105	106.00	190	190.84	275	275.47
7	7.64	24	24.50	41	40.45	110	110.86	195	196.00	280	280.84
8	8.72	25	25.37	42	41.59	115	115.37	200	200.86	285	286.00
9	9.78	26	26.23	43	42.73	120	119.56	205	205.37	290	290.86
10	10.84	27	27.07	44	43.88	125	124.00	210	209.56	295	295.37
11	11.90	28	27.79	45	45.00	130	129.32	215	214.00	300	299.21
12	12.94	29	28.73	50	50.68	135	135.00	220	219.32	305	303.02
13	13.97	30	29.56	55	56.00	140	140.68	225	225.00		
14	14.99	31	30.39	60	60.44	145	146.00	230	230.58		
15	16.00	32	31.24	65	64.63	150	150.44	235	236.00		
16	17.00	33	32.12	70	69.14	155	154.63	240	240.44		

Note: Temperature, voltage and nonlinearity not included.

[查询"CS4121EDWF20G"供应商](#) **CIRCUIT DESCRIPTION and APPLICATION NOTES**

The CS4121 is specifically designed for use with air-core meter movements. It includes an input comparator for sensing an input signal from an ignition pulse or speed sensor, a charge pump for frequency to voltage conversion, a bandgap voltage regulator for stable operation, and a function generator with sine and cosine amplifiers to differentially drive the meter coils.

From the partial schematic of Figure 7, the input signal is applied to the $FREQ_{IN}$ lead, this is the input to a high impedance comparator with a typical positive input threshold of 2.0 V and typical hysteresis of 0.5 V. The output of the comparator, SQ_{OUT} , is applied to the charge pump input $CP+$ through an external capacitor C_{CP} . When the input signal changes state, C_{CP} is charged or discharged through R3 and R4. The charge accumulated on C_{CP} is mirrored to C4 by the Norton Amplifier circuit comprising of Q1, Q2 and Q3. The charge pump output voltage, F/V_{OUT} , ranges from 2.0 V to 6.3 V depending on the input signal frequency and the gain of the charge pump according to the formula:

$$F/V_{OUT} = 2.0 V + 2.0 \times FREQ \times C_{CP} \times R_T \times (V_{REG} - 0.7 V)$$

R_T is a potentiometer used to adjust the gain of the F/V output stage and give the correct meter deflection. The F/V output voltage is applied to the function generator which generates the sine and cosine output voltages. The output voltage of the sine and cosine amplifiers are derived from the on-chip amplifier and function generator circuitry. The various trip points for the circuit (i.e., 0°, 90°, 180°, 270°) are determined by an internal resistor divider and the bandgap voltage reference. The coils are differentially driven, allowing bidirectional current flow in the outputs, thus providing up to 305° range of meter deflection. Driving the coils differentially offers faster response time, higher current capability, higher output voltage swings, and reduced external component count. The key advantage is a higher torque output for the pointer.

The output angle, θ , is equal to the F/V gain multiplied by the function generator gain:

$$\theta = AF/V \times AFG,$$

where:

$$AFG = 77^\circ/V(\text{typ})$$

The relationship between input frequency and output angle is:

$$\theta = AFG \times 2.0 \times FREQ \times C_{CP} \times R_T \times (V_{REG} - 0.7 V)$$

or,

$$\theta = 970 \times FREQ \times C_{CP} \times R_T$$

The ripple voltage at the F/V converter's output is determined by the ratio of C_{CP} and C4 in the formula:

$$\Delta V = \frac{C_{CP}(V_{REG} - 0.7 V)}{C4}$$

Ripple voltage on the F/V output causes pointer or needle flutter especially at low input frequencies.

The response time of the F/V is determined by the time constant formed by R_T and C4. Increasing the value of C4 will reduce the ripple on the F/V output but will also increase the response time. An increase in response time causes a very slow meter movement and may be unacceptable for many applications.

Design Example

Maximum meter Deflection = 270°

Maximum Input Frequency = 350 Hz

1. Select R_T and C_{CP}

$$\theta = 970 \times FREQ \times C_{CP} \times R_T = 270^\circ$$

Let $C_T = 0.0033 \mu F$, find R_T

$$R_T = \frac{270^\circ}{970 \times 350 \text{ Hz} \times 0.0033 \mu F}$$

$$R_T = 243 \text{ k}\Omega$$

R_T should be a 250 k Ω potentiometer to trim out any inaccuracies due to IC tolerances or meter movement pointer placement.

2. Select R3 and R4

Resistor R3 sets the output current from the voltage regulator. The maximum output current from the voltage regulator is 10 mA. R3 must ensure that the current does not exceed this limit.

Choose R3 = 3.3 k Ω

The charge current for C_{CP} is

$$\frac{V_{REG} - 0.7 V}{3.3 \text{ k}\Omega} = 1.90 \text{ mA}$$

C_{CP} must charge and discharge fully during each cycle of the input signal. Time for one cycle at maximum frequency is 2.85 ms. To ensure that C_{CP} is charged, assume that the (R3 + R4) C_{CP} time constant is less than 10% of the minimum input period.

$$T = 10\% \times \frac{1}{350 \text{ Hz}} = 285 \mu s$$

Choose R4 = 1.0 k Ω .

Discharge time: $t_{DCHG} = R3 \times C_{CP} = 3.3 \text{ k}\Omega \times 0.0033 \mu F = 10.9 \mu s$

Charge time: $t_{CHG} = (R3 + R4)C_{CP} = 4.3 \text{ k}\Omega \times 0.0033 \mu F = 14.2 \mu s$

3. Determine C4

C4 is selected to satisfy both the maximum allowable ripple voltage and response time of the meter movement.

$$C4 = \frac{C_{CP}(V_{REG} - 0.7 V)}{\Delta V_{MAX}}$$

With C4 = 0.47 μF , the F/V ripple voltage is 44 mV.

[查询"CS4121EDWF20G"供应商](#)

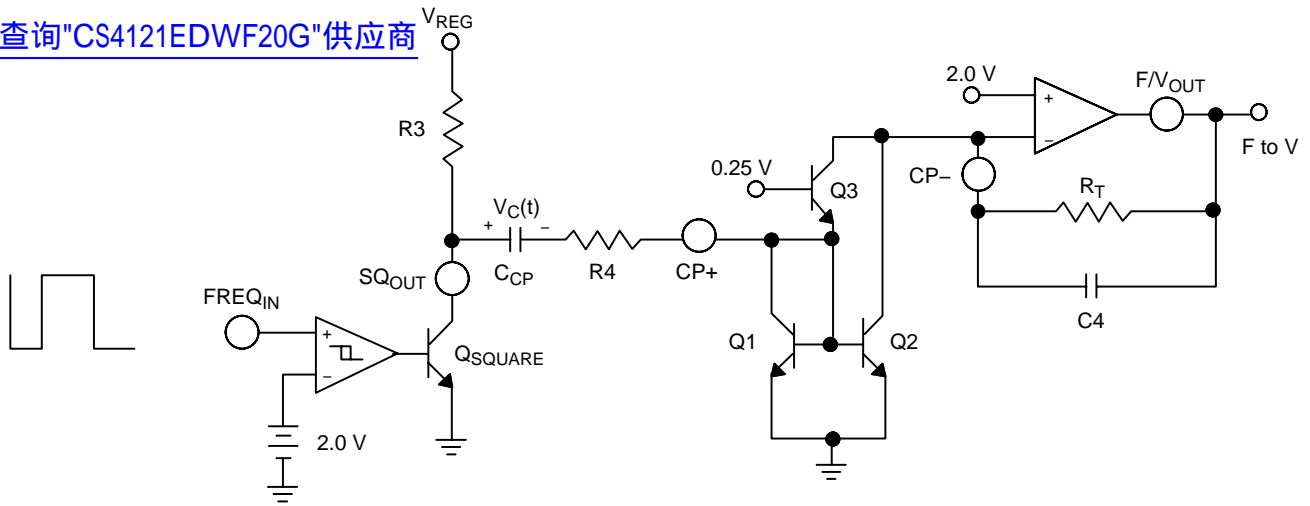

Figure 7. Partial Schematic of Input and Charge Pump

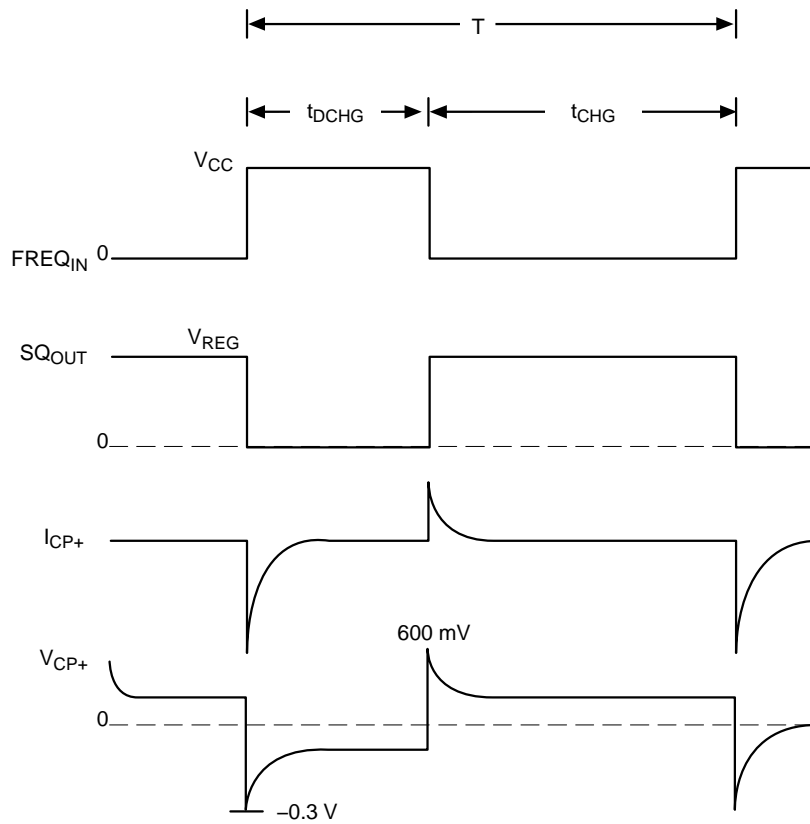
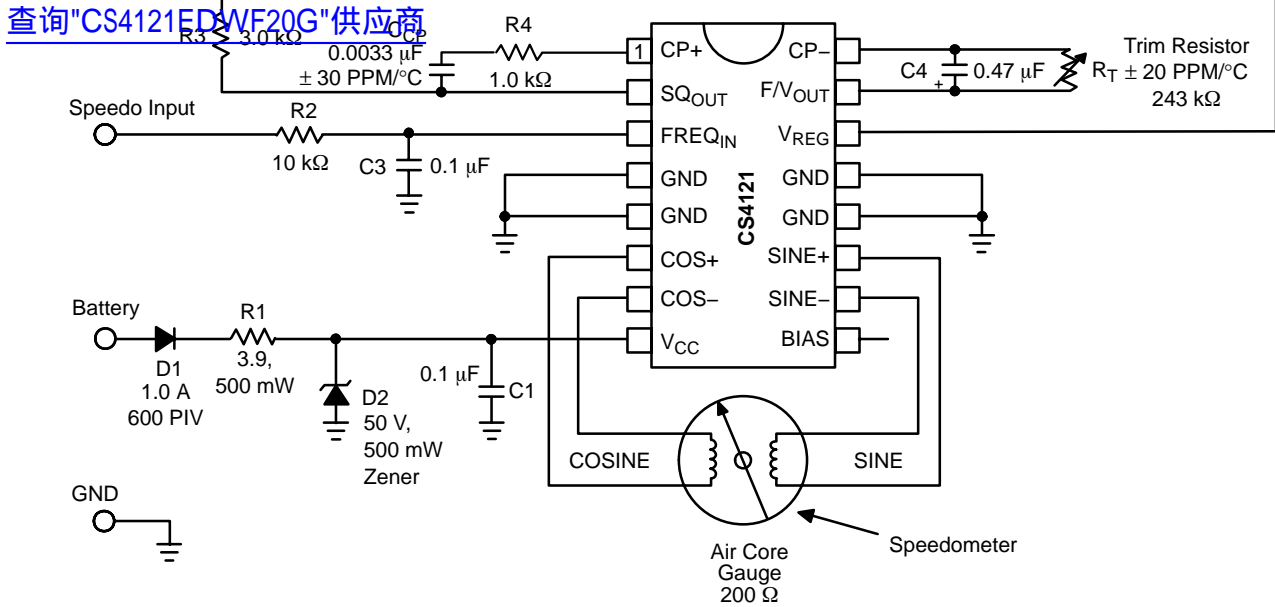

Figure 8. Timing Diagram of FREQ_IN and I_CP

CS4121



Notes:

1. For 58% Speed Input $T_{MAX} \leq 5.0/f_{MAX}$ where
 $T_{MAX} = C_{CP} (R3 + R4)$
 f_{MAX} = maximum speed input frequency
2. The product of C4 and R_T have a direct effect on gain and therefore directly affect temperature compensation.
3. C_{CP} Range; 20 pF to 0.2 μ F.
4. R_T Range; 100 k Ω to 500 k Ω .
5. The IC must be protected from transients above 60 V and reverse battery conditions.
6. Additional filtering on FREQ_{IN} lead may be required.
7. Gauge coil connections to the IC must be kept as short as possible (≤ 3.0 inch) for best pointer stability.

Figure 9. Speedometer or Tachometer Application

CS4121

[查询"CS4121EDWF20G"供应商](#)

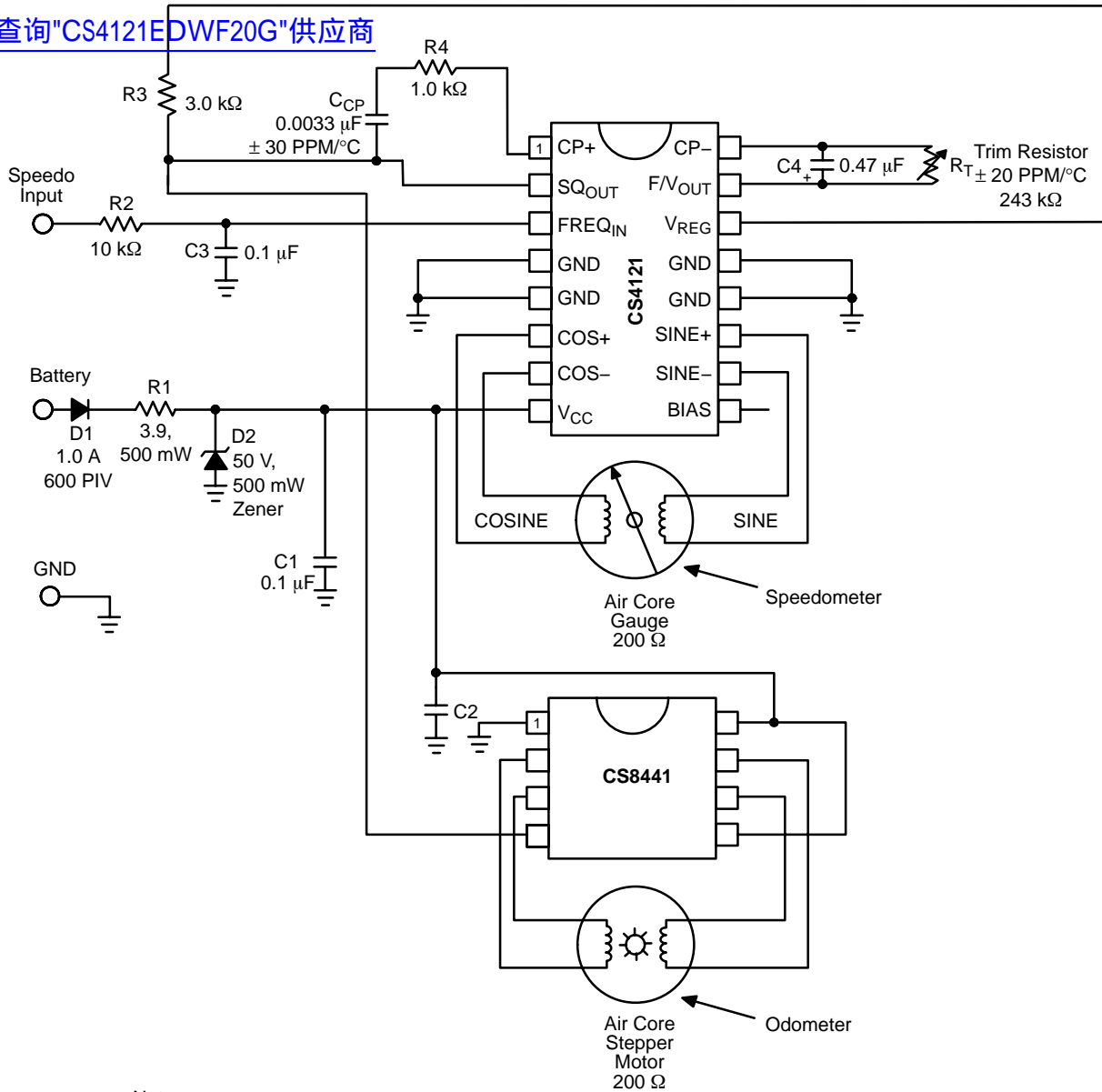

Notes:

1. The product of C₄ and R_T have a direct effect on gain and therefore directly affect temperature compensation.
2. C_{CP} Range; 20 pF to 0.2 μF.
3. R_T Range; 100 kΩ to 500 kΩ.
4. The I_c must be protected from transients above 60 V and reverse battery conditions.
5. Additional filtering on FREQ_{IN} lead may be required.
6. Gauge coil connections to the IC must be kept as short as possible (≤ 3.0 inch) for best pointer stability.

Figure 10. Speedometer With Odometer or Tachometer Application

CS4121

[查询"CS4121EDWF20G"供应商](#)

PACKAGE DIMENSIONS

DIP-16
NF SUFFIX
CASE 648-08
ISSUE T

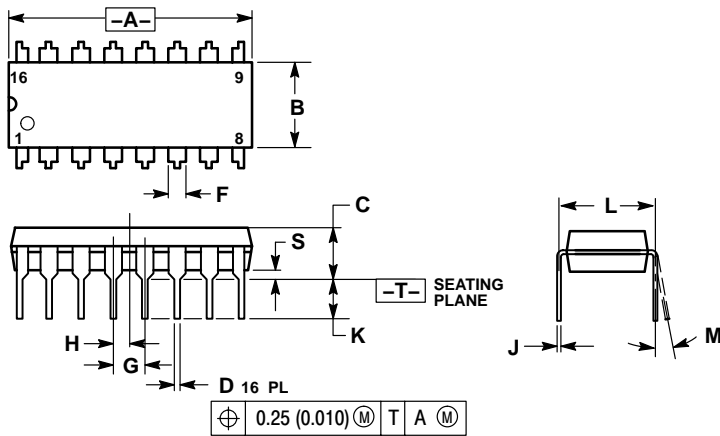

NOTES:

1. DIMENSIONING AND TOLERANCING PER ANSI Y14.5M, 1982.
2. CONTROLLING DIMENSION: INCH.
3. DIMENSION L TO CENTER OF LEADS WHEN FORMED PARALLEL.
4. DIMENSION B DOES NOT INCLUDE MOLD FLASH.
5. ROUNDED CORNERS OPTIONAL.

DIM	INCHES		MILLIMETERS	
	MIN	MAX	MIN	MAX
A	0.740	0.770	18.80	19.55
B	0.250	0.270	6.35	6.85
C	0.145	0.175	3.69	4.44
D	0.015	0.021	0.39	0.53
F	0.040	0.70	1.02	1.77
G	0.100 BSC		2.54 BSC	
H	0.050 BSC		1.27 BSC	
J	0.008	0.015	0.21	0.38
K	0.110	0.130	2.80	3.30
L	0.295	0.305	7.50	7.74
M	0°	10°	0°	10°
S	0.020	0.040	0.51	1.01

SO-20L
DWF SUFFIX
CASE 751D-05
ISSUE G

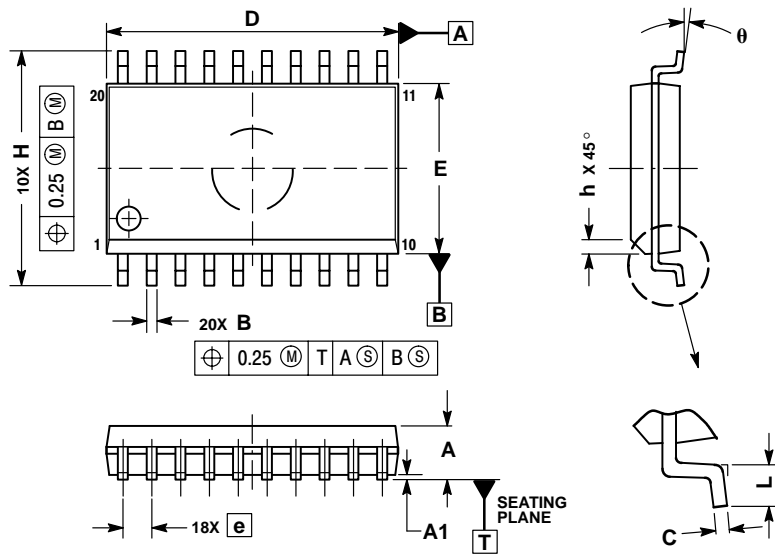

NOTES:

1. DIMENSIONS ARE IN MILLIMETERS.
2. INTERPRET DIMENSIONS AND TOLERANCES PER ASME Y14.5M, 1994.
3. DIMENSIONS D AND E DO NOT INCLUDE MOLD PROTRUSION.
4. MAXIMUM MOLD PROTRUSION 0.15 PER SIDE.
5. DIMENSION B DOES NOT INCLUDE DAMBAR PROTRUSION. ALLOWABLE PROTRUSION SHALL BE 0.13 TOTAL IN EXCESS OF B DIMENSION AT MAXIMUM MATERIAL CONDITION.

DIM	MILLIMETERS	
	MIN	MAX
A	2.35	2.65
A1	0.10	0.25
B	0.35	0.49
C	0.23	0.32
D	12.65	12.95
E	7.40	7.60
e	1.27 BSC	
H	10.05	10.55
h	0.25	0.75
L	0.50	0.90
theta	0°	7°

PACKAGE THERMAL DATA

Parameter		DIP-16	SO-20L	Unit
R _{thetaJC}	Typical	15	9	°C/W
R _{thetaJA}	Typical	50	55	°C/W

[查询"CS4121EDWF20G"供应商](#)

ON Semiconductor and  are registered trademarks of Semiconductor Components Industries, LLC (SCILLC). SCILLC reserves the right to make changes without further notice to any products herein. SCILLC makes no warranty, representation or guarantee regarding the suitability of its products for any particular purpose, nor does SCILLC assume any liability arising out of the application or use of any product or circuit, and specifically disclaims any and all liability, including without limitation special, consequential or incidental damages. "Typical" parameters which may be provided in SCILLC data sheets and/or specifications can and do vary in different applications and actual performance may vary over time. All operating parameters, including "Typicals" must be validated for each customer application by customer's technical experts. SCILLC does not convey any license under its patent rights nor the rights of others. SCILLC products are not designed, intended, or authorized for use as components in systems intended for surgical implant into the body, or other applications intended to support or sustain life, or for any other application in which the failure of the SCILLC product could create a situation where personal injury or death may occur. Should Buyer purchase or use SCILLC products for any such unintended or unauthorized application, Buyer shall indemnify and hold SCILLC and its officers, employees, subsidiaries, affiliates, and distributors harmless against all claims, costs, damages, and expenses, and reasonable attorney fees arising out of, directly or indirectly, any claim of personal injury or death associated with such unintended or unauthorized use, even if such claim alleges that SCILLC was negligent regarding the design or manufacture of the part. SCILLC is an Equal Opportunity/Affirmative Action Employer. This literature is subject to all applicable copyright laws and is not for resale in any manner.

PUBLICATION ORDERING INFORMATION

LITERATURE FULFILLMENT:

Literature Distribution Center for ON Semiconductor
P.O. Box 5163, Denver, Colorado 80217 USA

Phone: 303-675-2175 or 800-344-3860 Toll Free USA/Canada

Fax: 303-675-2176 or 800-344-3867 Toll Free USA/Canada

Email: orderlit@onsemi.com

N. American Technical Support: 800-282-9855 Toll Free
USA/Canada

Japan: ON Semiconductor, Japan Customer Focus Center

2-9-1 Kamimeguro, Meguro-ku, Tokyo, Japan 153-0051

Phone: 81-3-5773-3850

ON Semiconductor Website: <http://onsemi.com>

Order Literature: <http://www.onsemi.com/litorder>

For additional information, please contact your
local Sales Representative.