

30N06

MOSFET

30 Amps, 60 Volts  
 N-CHANNEL POWER MOSFET

DESCRIPTION

The UTC 30N06 is a low voltage MOSFET and is designed to have better characteristics, such as fast switching time, low gate charge, low on-state resistance and excellent avalanche characteristics. This power MOSFET is usually used at automotive applications in power supplies, high efficient DC to DC converters and battery operated products.

FEATURES

- \*  $R_{DS(ON)} = 40m\Omega @ V_{GS} = 10V$
- \* Ultra low gate charge ( typical 20 nC )
- \* Low reverse transfer Capacitance (  $C_{RSS} =$  typical 80 pF )
- \* Fast switching capability
- \* 100% avalanche energy specified
- \* Improved dv/dt capability

SYMBOL

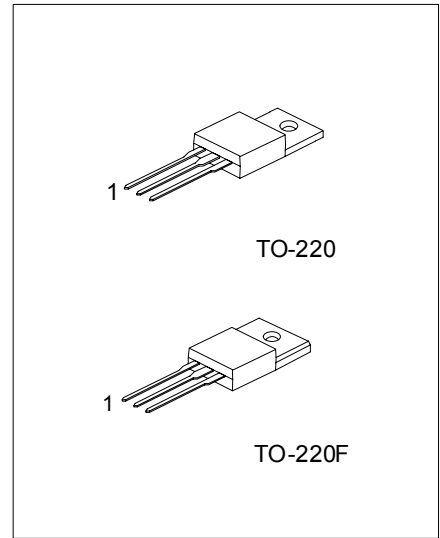
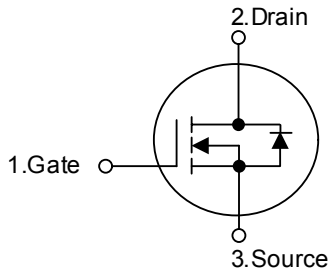

\*Pb-free plating product number: 30N06L

ORDERING INFORMATION

Order Number		Package	Pin Assignment			Packing
Normal	Lead Free Plating		1	2	3	
30N06-TA3-T	30N06L-TA3-T	TO-220	G	D	S	Tube
30N06-TF3-T	30N06L-TF3-T	TO-220F	G	D	S	Tube

Note: Pin Assignment: G: Gate D: Drain S: Source

<p>30N06L-TA3-T</p>	<p>(1) T: Tube, R: Tape Reel</p> <p>(2) TA3: TO-220, TF3: TO-220F</p> <p>(3) L: Lead Free Plating Blank: Pb/Sn</p>
---------------------	--

■ ABSOLUTE MAXIMUM RATINGS

PARAMETER	SYMBOL	RATINGS	UNIT	
Drain-Source Voltage	$V_{DSS}$	60	V	
Gate to Source Voltage	$V_{GSS}$	$\pm 20$	V	
Continuous Drain Current	$I_D$	$T_C = 25$	30	A
		$T_C = 100$	21.3	A
Pulsed Drain Current (Note 1)	$I_{DM}$	120	A	
Avalanche Energy, Single Pulsed (Note 2)	$E_{AS}$	300	mJ	
Repetitive Avalanche Energy (Note 1)	$E_{AR}$	8	mJ	
Peak Diode Recovery dv/dt (Note 3)	dv/dt	7.5	V/ns	
Total Power Dissipation ( $T_C = 25$ )	$P_D$	80	W	
Derating Factor Above 25		0.53	W/	
Operation Junction Temperature	$T_J$	-55 ~ +150		
Storage Temperature	$T_{STG}$	-55 ~ +150		

Note: Absolute maximum ratings are those values beyond which the device could be permanently damaged. Absolute maximum ratings are stress ratings only and functional device operation is not implied.

■ THERMAL DATA

PARAMETER	SYMBOL	MIN	TYP	MAX	UNIT
Thermal Resistance, Junction-to-Case	$\theta_{JC}$			1.8	$^{\circ}\text{C/W}$
Thermal Resistance, Case-to-Sink	$\theta_{CS}$		0.5		$^{\circ}\text{C/W}$
Thermal Resistance, Junction-to-Ambient	$\theta_{JA}$			62.5	$^{\circ}\text{C/W}$

■ ELECTRICAL CHARACTERISTICS ( $T_C = 25$ , unless otherwise specified)

PARAMETER	SYMBOL	TEST CONDITIONS	MIN	TYP	MAX	UNIT
<b>Off Characteristics</b>						
Drain-Source Breakdown Voltage	$BV_{DSS}$	$V_{GS} = 0\text{ V}, I_D = 250\ \mu\text{A}$	60			V
Drain-Source Leakage Current	$I_{DSS}$	$V_{DS} = 60\text{ V}, V_{GS} = 0\text{ V}$			1	$\mu\text{A}$
		$V_{DS} = 48\text{ V}, V_{GS} = 0\text{ V}, T_J = 150$			10	$\mu\text{A}$
Gate-Source Leakage Current	Forward	$I_{GSS}$	$V_{GS} = 20\text{ V}, V_{DS} = 0\text{ V}$		100	nA
	Reverse			$V_{GS} = -20\text{ V}, V_{DS} = 0\text{ V}$		-100
Breakdown Voltage Temperature Coefficient	$BV_{DSS}/T_J$	$I_D = 250\ \mu\text{A}$ , Referenced to 25		0.06		V/
<b>On Characteristics</b>						
Gate Threshold Voltage	$V_{GS(TH)}$	$V_{DS} = V_{GS}, I_D = 250\ \mu\text{A}$	2.0		4.0	V
Static Drain-Source On-State Resistance	$R_{DS(ON)}$	$V_{GS} = 10\text{ V}, I_D = 15\text{ A}$		32	40	m $\Omega$
<b>Dynamic Characteristics</b>						
Input Capacitance	$C_{ISS}$	$V_{GS} = 0\text{ V}, V_{DS} = 25\text{ V}, f = 1\text{ MHz}$		800		pF
Output Capacitance	$C_{OSS}$			300		pF
Reverse Transfer Capacitance	$C_{RSS}$			80		pF
<b>Switching Characteristics</b>						
Turn-On Delay Time	$t_{D(ON)}$	$V_{DD} = 30\text{ V}, I_D = 15\text{ A}, V_{GS} = 10\text{ V}$ (Note 4, 5)		12		ns
Turn-On Rise Time	$t_R$			79		ns
Turn-Off Delay Time	$t_{D(OFF)}$			50		ns
Turn-Off Fall Time	$t_F$			52		ns
Total Gate Charge	$Q_G$	$V_{DS} = 60\text{ V}, V_{GS} = 10\text{ V}, I_D = 24\text{ A}$ (Note 4, 5)		20	30	nC
Gate-Source Charge	$Q_{GS}$			6		nC
Gate-Drain Charge (Miller Charge)	$Q_{GD}$			9		nC

■ ELECTRICAL CHARACTERISTICS (Cont.)

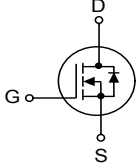
PARAMETER	SYMBOL	TEST CONDITIONS	MIN	TYP	MAX	UNIT
<b>Source-Drain Diode Ratings and Characteristics</b>						
Diode Forward Voltage	$V_{SD}$	$I_S = 30A, V_{GS} = 0V$			1.4	V
Maximum Continuous Drain-Source Diode Forward Current	$I_S$	Integral Reverse p-n Junction Diode in the MOSFET 			30	A
Maximum Pulsed Drain-Source Diode Forward Current	$I_{SM}$				120	A
Reverse Recovery Time	$t_{RR}$	$I_S = 30A, V_{GS} = 0V$		40		ns
Reverse Recovery Charge	$Q_{RR}$	$di_F / dt = 100 A/\mu s$ (Note4)		70		$\mu C$

Note 1. Repeativity rating: pulse width limited by junction temperature

2.  $L=19.5mH, I_{AS}=30A, R_G=20\Omega$ , Starting  $T_J=25$

3.  $I_{SD} \leq 50A, di/dt \leq 300A/\mu s, V_{DD} \leq BV_{DSS}$ , Starting  $T_J=25$

4. Pulse Test: Pulse Width  $\leq 300\mu s$ , Duty Cycle  $\leq 2\%$

5. Essentially independent of operating temperature.

■ TEST CIRCUITS AND WAVEFORMS

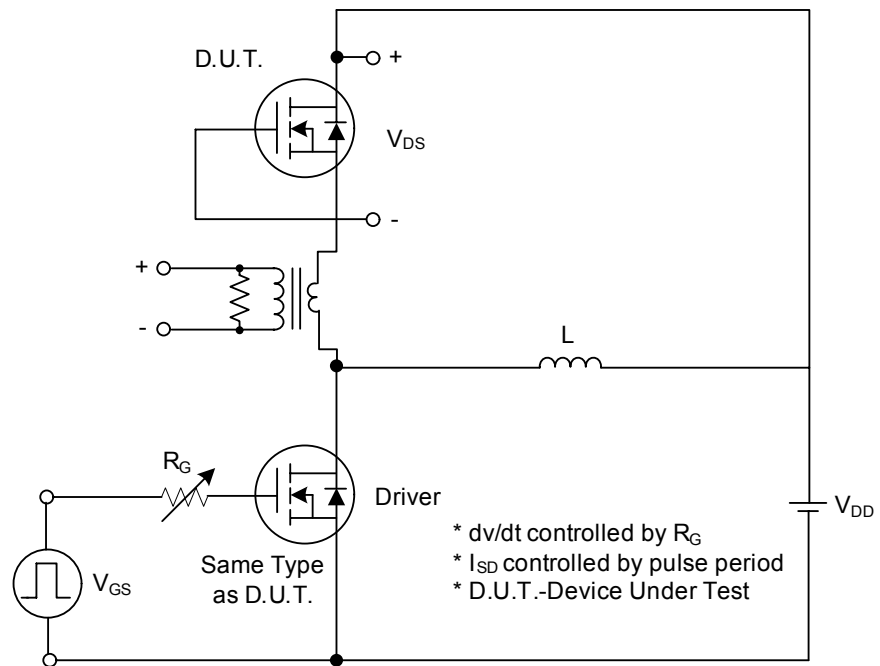

Fig. 1A Peak Diode Recovery  $dv/dt$  Test Circuit

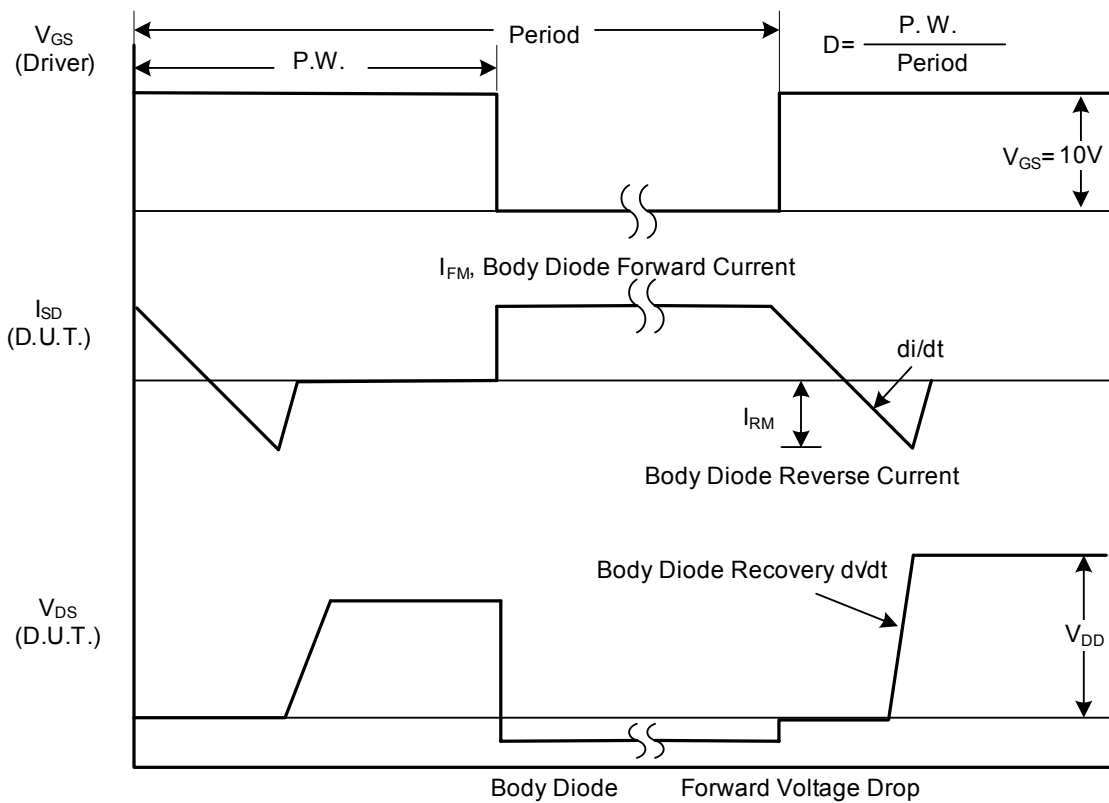

Fig. 1B Peak Diode Recovery  $dv/dt$  Waveforms

■ TEST CIRCUITS AND WAVEFORMS (Cont.)

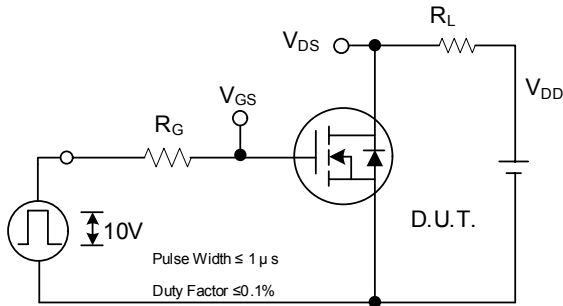

Fig. 2A Switching Test Circuit

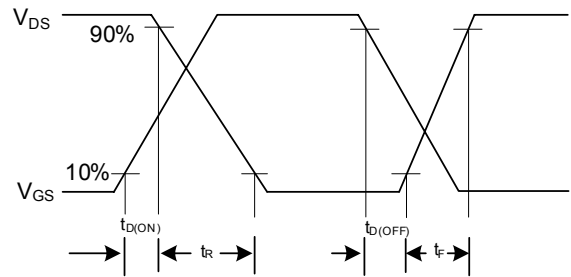

Fig. 2B Switching Waveforms

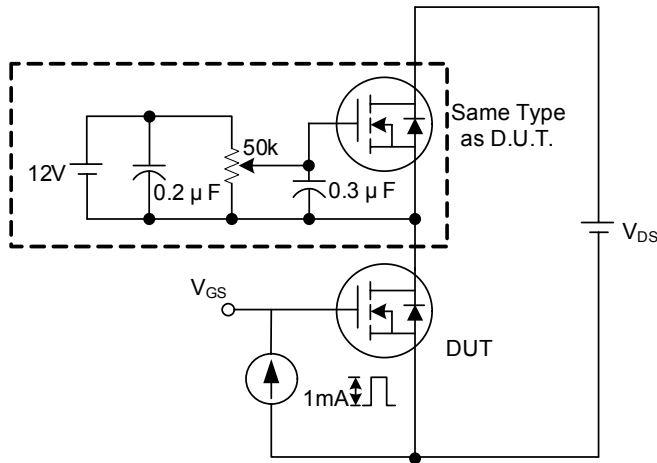

Fig. 3A Gate Charge Test Circuit

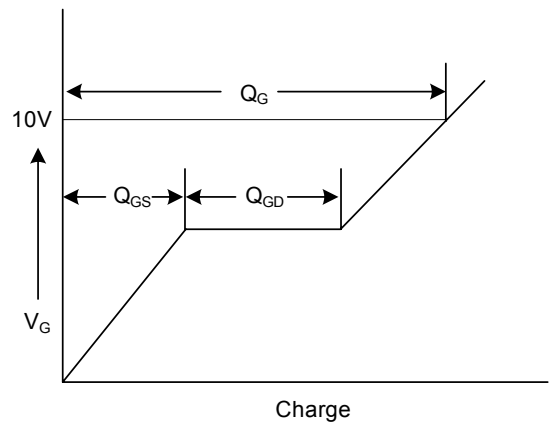

Fig. 3B Gate Charge Waveform

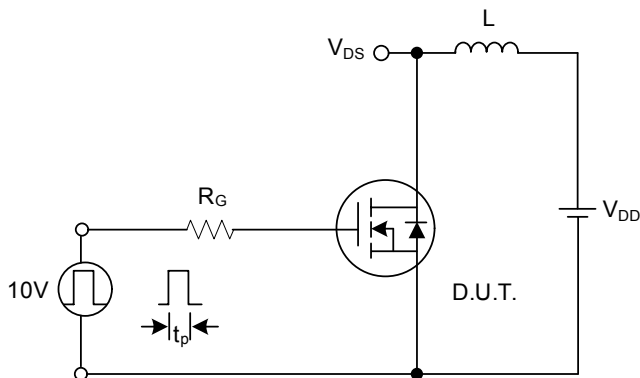

Fig. 4A Unclamped Inductive Switching Test Circuit

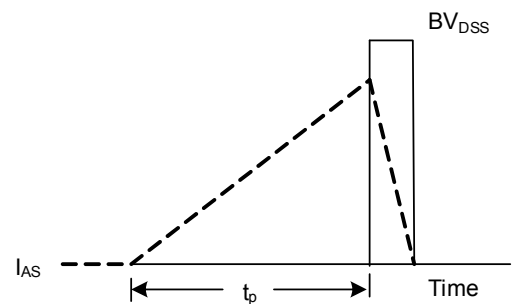
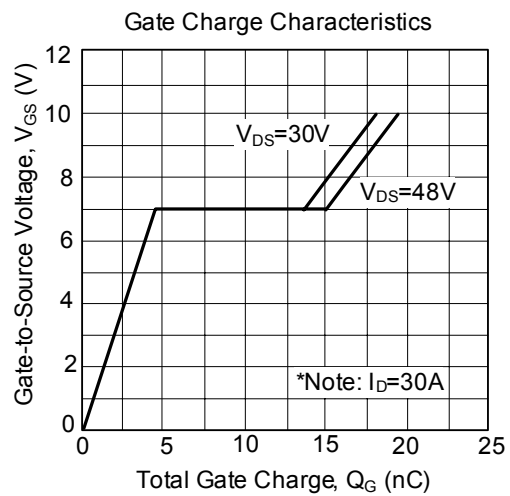
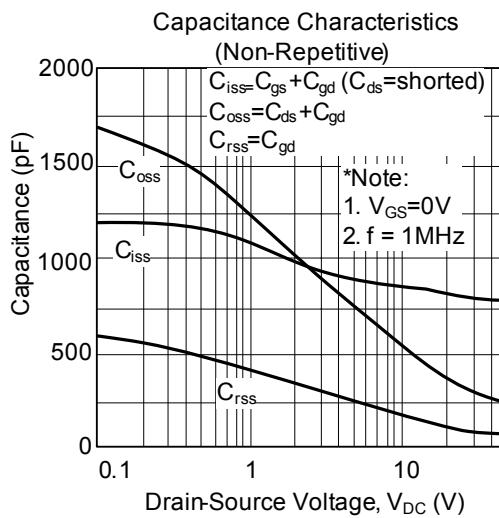
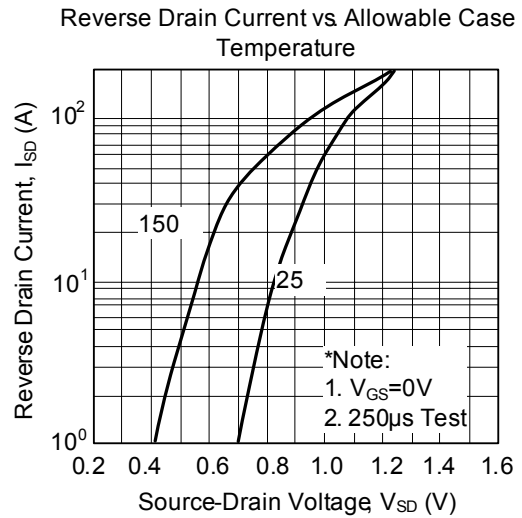
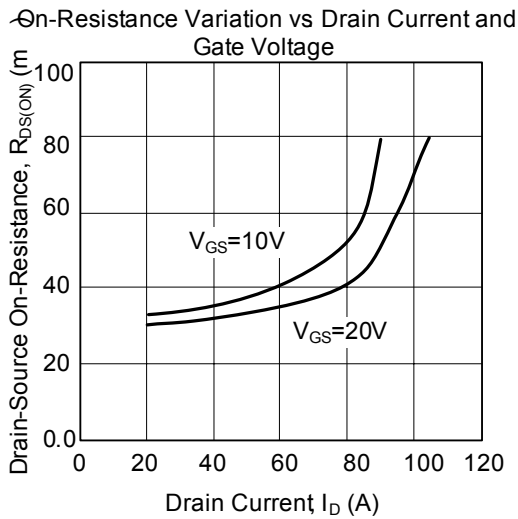
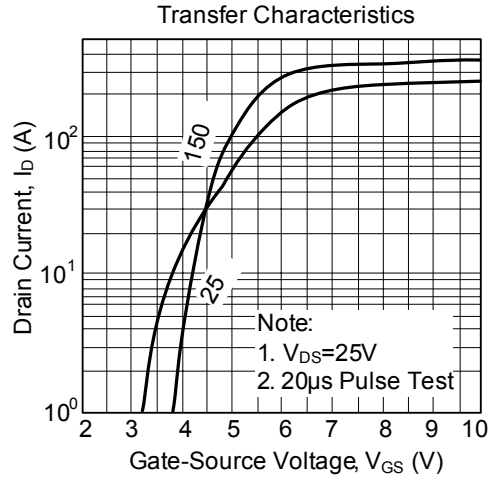
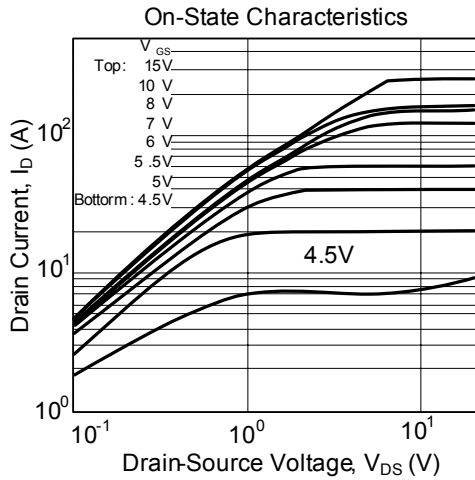
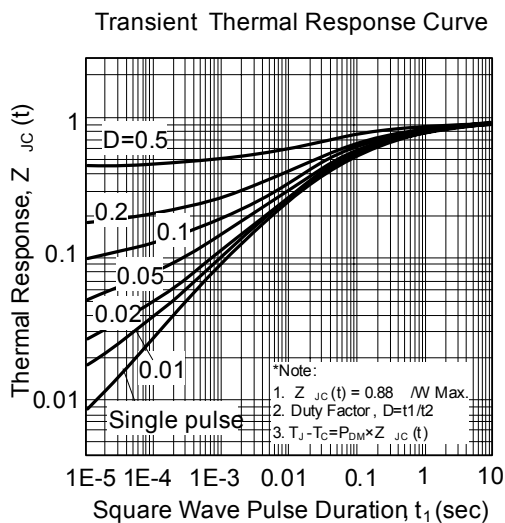
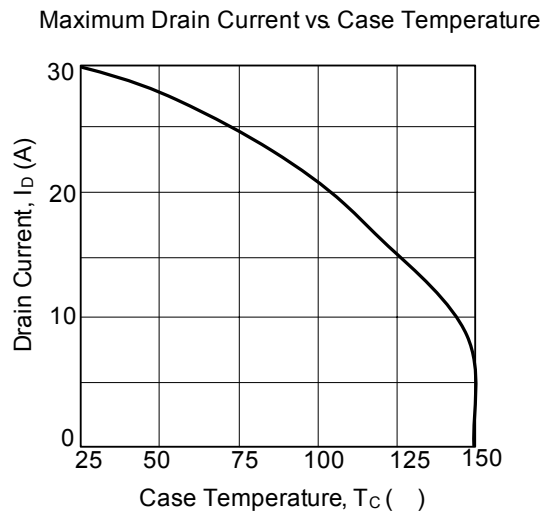
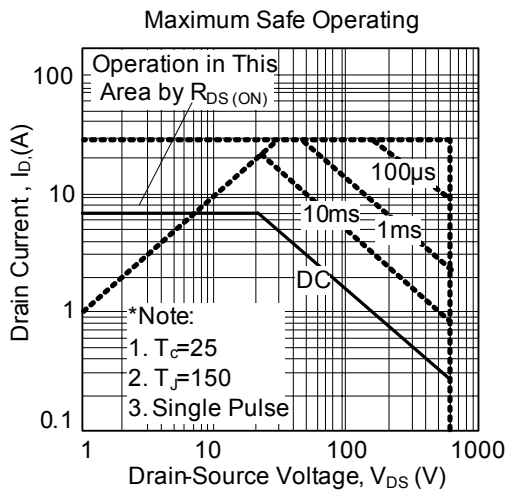
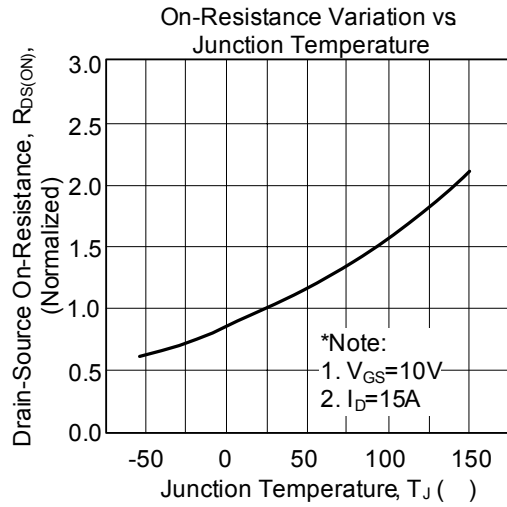
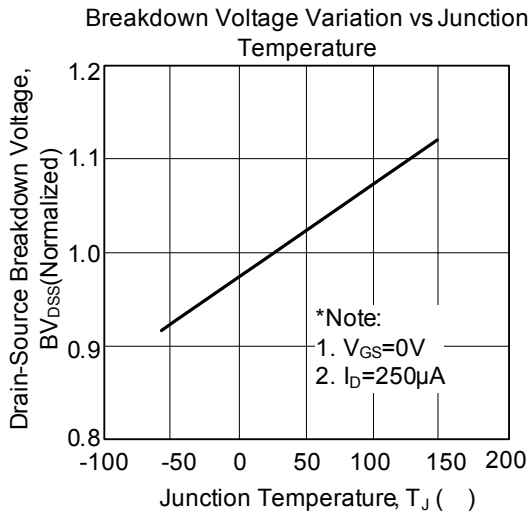

Fig. 4B Unclamped Inductive Switching Waveforms

■ TYPICAL CHARACTERISTICS



■ TYPICAL CHARACTERISTICS(Cont.)



UTC assumes no responsibility for equipment failures that result from using products at values that exceed, even momentarily, rated values (such as maximum ratings, operating condition ranges, or other parameters) listed in products specifications of any and all UTC products described or contained herein. UTC products are not designed for use in life support appliances, devices or systems where malfunction of these products can be reasonably expected to result in personal injury. Reproduction in whole or in part is prohibited without the prior written consent of the copyright owner. The information presented in this document does not form part of any quotation or contract, is believed to be accurate and reliable and may be changed without notice.