

1-to-2 Decoder/ Demultiplexer

The NL7SZ19 is a 1-to-2 decoder. When the output enable (\bar{E}) is Low, the device passes data at input A to outputs Y0 (true) and Y1 (complement). The NL7SZ19 can also be used as a 1-to-2 demultiplexer. As a demultiplexer, data at input \bar{E} is routed to either Y0 or Y1 depending on the state of A. The device operates over the voltage range from 1.65 V to 5.5 V. The device is fabricated in sub-micron CMOS for high speed and fast decode times. Both inputs and outputs are in high impedance state, when supply voltage is powered down. Both inputs are tolerant of voltages up to 5.5 V, regardless of operating voltage. This device is suitable for low power decoding in a variety of applications.

Features

- High-Speed Propagation Delay:
 t_{PD} 2.7 nS (Typ), Load 50 pF @ 5.0 V
- 32 mA Output Drive Capability @ 5.0 V
- Power Down Impedance: Inputs/Outputs in High-Z
- Broad V_{CC} Operating Range: 1.65 V to 5.5 V
- Surface Mount Technology: SC-70, 6-Lead and UDFN6 Packaging
- OVT* on I/Os
- Pb-Free Package is Available

Typical Applications

- Cell Phones
- PDAs
- Digital Cameras
- Video Cameras

Important Information

- ESD Protection: Human Body Model >2000 V
- Latchup Max Rating: 300 mA
- Pin to Pin Compatible with NC7SZ19

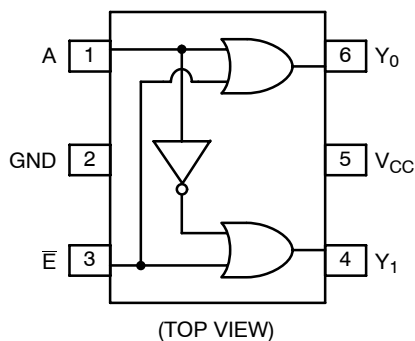

Figure 1. Pinout

*Over Voltage Tolerance (OVT) enables input and output pins to function outside (higher) of their operating voltages, with no damage to the devices or to signal integrity.



ON Semiconductor®

<http://onsemi.com>

MARKING DIAGRAM

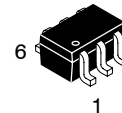

SOT-363/SC70-6/SC-88
DF SUFFIX
CASE 419B

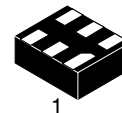
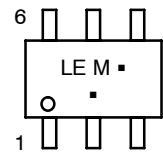

UDFN6
MU SUFFIX
CASE 517AA



LE, U = Device Marking
M = Date Code*
▪ = Pb-Free Package

(Note: Microdot may be in either location)
*Date Code orientation may vary depending upon manufacturing location.

PIN/FUNCTION TABLE

Pin	Function Description	
	As Decoder	As Demultiplexer
A	Address	Select
\bar{E}	Output Enable	Data
Y ₀	Output 0	Output 0
Y ₁	Output 1	Output 1

TRUTH TABLE

\bar{E}	A	Y ₀ = A + \bar{E}	Y ₁ = \bar{A} + \bar{E}
L	L	L	H
L	H	H	L
H	H	H	H
H	L	H	H

ORDERING INFORMATION

See detailed ordering and shipping information in the package dimensions section on page 2 of this data sheet.

NL7SZ19

MAXIMUM RATINGS

Symbol	Rating	Value	Unit
V _{CC}	DC Supply Voltage	-0.5 to +7.0	V
V _{IN}	DC Input Voltage	-0.5 to +7.0	V
V _{OUT}	DC Output Voltage	-0.5 to +7.0	V
I _{IK}	DC Input Diode Current @ V ₁ < -0.5 V	-50	mA
I _{OK}	DC Output Diode Current @ V ₁ < -0.5 V	-50	mA
I _{OUT}	DC Output Sink Current	± 50	mA
I _{CC}	DC Supply Current per Supply Pin	± 100	mA
I _{GND}	DC Ground Current per Ground Pin	± 100	mA
T _{STG}	Storage Temperature Range	-65 to +150	°C
T _L	Lead Temperature, 1 mm from Case for 10 Seconds	260	°C
T _J	Junction Temperature Under Bias	+150	°C
θ _{JA}	Thermal Resistance (Note 1)	250	°C/W
P _D	Power Dissipation in Still Air at 85°C	180	mW
MSL	Moisture Sensitivity	Level 1	-
F _R	Flammability Rating Oxygen Index: 28 to 34	UL 94 V-0 @ 0125 in	-
V _{ESD}	ESD Withstand Voltage Human Body Model (Note 2) Machine Model (Note 3) Charged Device Model (Note 4)	> 2000 > 150 n/a	V

Stresses exceeding Maximum Ratings may damage the device. Maximum Ratings are stress ratings only. Functional operation above the Recommended Operating Conditions is not implied. Extended exposure to stresses above the Recommended Operating Conditions may affect device reliability.

1. Measured with minimum pad spacing on an FR4 board, using 10 mm-by-1 inch, 2 ounce copper trace no air flow.
2. Tested to EIA/JESD22-A114-A.
3. Tested to EIA/JESD22-A115-A.
4. Tested to JESD22-C101-A.

RECOMMENDED OPERATING CONDITIONS

Symbol	Rating	Value	Unit
V _{CC}	DC Supply Voltage	1.65 to 5.5	V
V _{CC}	DC Supply Voltage, Data Retention	1.5 to 5.5	V
V _{IN}	Input Voltage	0 to 5.5	V
V _{OUT}	Output Voltage	0 to 5.5	V
T _A	Operating Temperature	-40 to 85	°C
t _r , t _f	Input Rise and Fall Times V _{CC} @ 1.8 ± 0.15 V V _{CC} @ 2.5 ± 0.2 V V _{CC} @ 3.3 ± 0.3 V V _{CC} @ 5.0 ± 0.5 V	0 to 20 0 to 20 0 to 10 0 to 5	nS/V
θ _{JA}	Thermal Resistance	350	°C/W

ORDERING INFORMATION

Device Order Number	Package	Shipping†
NL7SZ19DFT2	SC70-6	3000 / Tape & Reel
NL7SZ19DFT2G	SC70-6 (Pb-Free)	3000 / Tape & Reel
NL7SZ19MUR2G	UDFN6 (Pb-Free)	3000 / Tape & Reel

†For information on tape and reel specifications, including part orientation and tape sizes, please refer to our Tape and Reel Packaging Specifications Brochure, BRD8011/D.

NL7SZ19

DC ELECTRICAL CHARACTERISTICS

Symbol	Parameter	Condition	V _{CC} (V)	T _A = 25°C			T _A = -40°C to 85°C		Unit	
				Min	Typ	Max	Min	Max		
V _{IH}	High-Level Input Voltage		1.65 2.3 to 5.5	0.75 V _{CC} 0.70 V _{CC}			0.75 V _{CC} 0.70 V _{CC}		V	
V _{IL}	Low-Level Output Voltage		1.65 2.3-5.5			0.25 V _{CC} 0.30 V _{CC}		0.25 V _{CC} 0.30 V _{CC}	V	
V _{OH}	High-Level Output Voltage	V _{IN} = V _{IH} or V _{IL}	I _{OH} = -100 μA	1.65	1.55	1.65		1.55		V
				2.3	2.20	2.30		2.20		
				3.0	2.90	3.00		2.90		
				4.5	4.40	4.50		4.40		
				1.65	1.29	1.47		1.29		
				2.3	1.90	2.10		1.90		
3.0	2.40	2.75		2.40						
3.0	2.30	2.63		2.30						
4.5	3.80	4.15		3.80						
V _{OL}	Low-Level Output Voltage	V _{IN} = V _{IL} or V _{IH}	I _{OL} = 100 μA	1.65		0.0	0.10		0.10	V
				2.3		0.0	0.10		0.10	
				3.0		0.0	0.10		0.10	
				4.5		0.0	0.10		0.10	
				1.65	0.09	0.24		0.24		
				2.3	0.12	0.30		0.30		
3.0	0.20	0.40		0.40						
3.0	0.30	0.55		0.55						
4.5	0.32	0.55		0.55						
I _{IN}	Input Leakage Current	V _{IN} = 5.5 V, GND	0.0 to 5.5			±0.1		±1.0	μA	
I _{OFF}	Power-Off Leakage Current	V _{IN} or V _{OUT} = 5.5 V	0.0			1.0		10	μA	
I _{CC}	Quiescent Supply Current	V _{IN} = 5.5 V, GND	1.65 to 5.5			1.0		10	μA	

AC ELECTRICAL CHARACTERISTICS

Symbol	Parameter	Condition	V _{CC}	T _A = 25°C			T _A = -40°C to 85°C		Unit	Figure
				Min	Typ	Max	Min	Max		
t _{PLH} t _{PHL}	Propagation Delay A or • to Y ₀ or Y ₁	C _L = 15 pF R _D = 1.0 MΩ	1.8 ± 0.15	2.5	6.2	10.5	2.5	11	nS	Figures 1 & 3
			2.5 ± 0.2	1.2	3.6	6.0	1.2	6.4		
			3.3 ± 0.3	0.8	2.9	4.1	0.8	4.5		
			5.0 ± 0.5	0.5	2.4	3.2	0.5	3.5		
		C _L = 50 pF R _D = 500 Ω	3.3 ± 0.3	1.2	3.2	5.1	1.2	5.4	nS	Figures 1 & 3
			5.0 ± 0.5	0.8	2.7	4.0	0.8	4.3		
C _{IN}	Input Capacitance		0		2.3				pF	
C _{PD}	Power Dissipation Capacitance	Note 5	3.3 5.0		10.5 12.8				pF	Figure 2

5. C_{PD} is defined as the value of the internal equivalent capacitance which is derived from dynamic operating current consumption (I_{CCD}) at no output loading and operating at 50% duty cycle (see Figure 2). C_{PD} is related to I_{CCD} dynamic operating current by the expression: I_{CCD} = (C_{PD}) (V_{CC}) (f_{IN}) + (I_{CCD}static).

NL7SZ19

[查询"NL7SZ19_0"供应商](#)

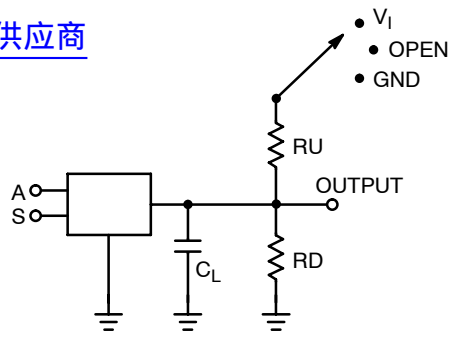

Figure 1. AC Test Circuit

C_L Includes Load and Stray Capacitance
 Input PRR = 1.0 MHz; $t_W = 500$ ns

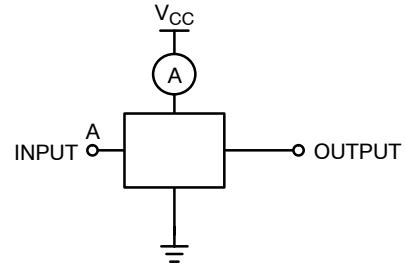

Figure 2. I_{CCD} Test Circuit

Input = AC Waveform; $t_r = t_f = 1.8$ nS
 PRR = 10 MHz; Duty Cycle = 50%
 S Input = GND or x

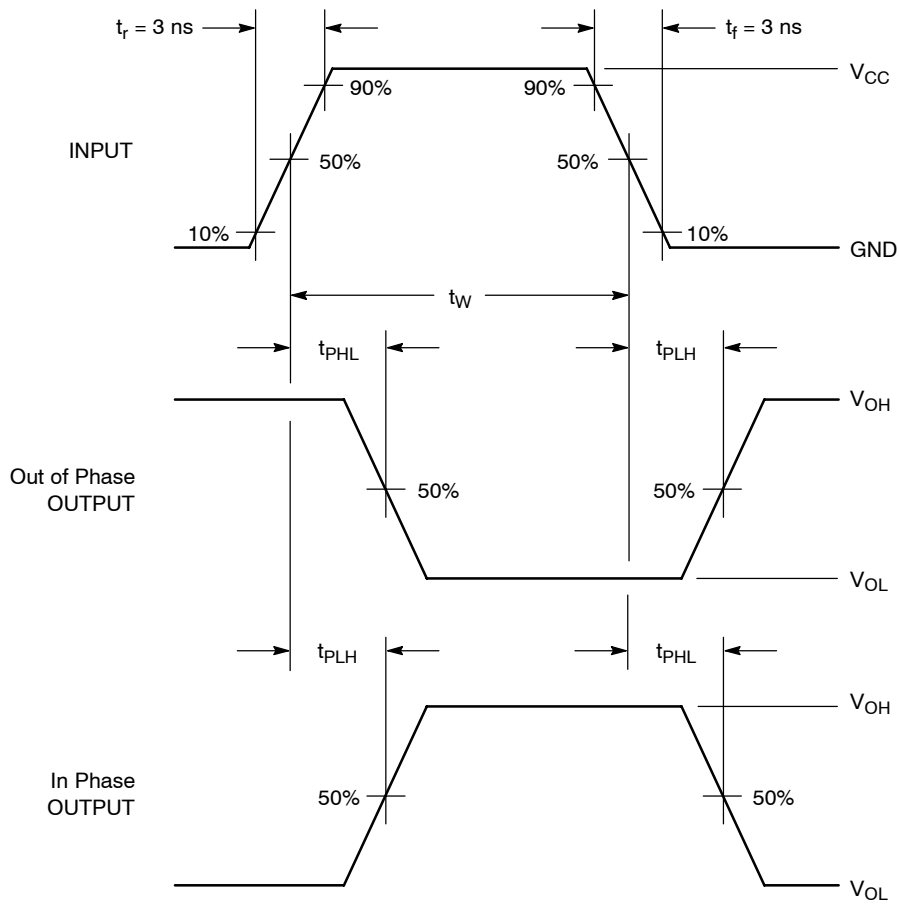

Figure 3. AC Waveforms

NL7SZ19

[查询"NL7SZ19_0"供应商](#)

PACKAGE DIMENSIONS

SC-88/SC70-6/SOT-363
CASE 419B-02
ISSUE W

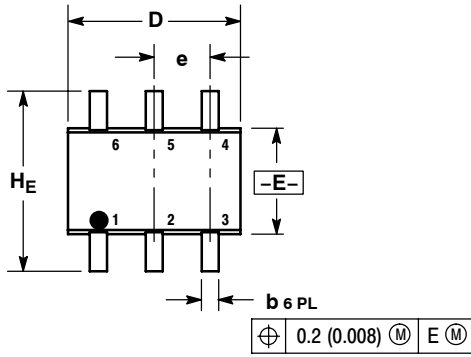

- NOTES:
1. DIMENSIONING AND TOLERANCING PER ANSI Y14.5M, 1982.
2. CONTROLLING DIMENSION: INCH.
3. 419B-01 OBSOLETE, NEW STANDARD 419B-02.

DIM	MILLIMETERS			INCHES		
	MIN	NOM	MAX	MIN	NOM	MAX
A	0.80	0.95	1.10	0.031	0.037	0.043
A1	0.00	0.05	0.10	0.000	0.002	0.004
A3	0.20 REF			0.008 REF		
b	0.10	0.21	0.30	0.004	0.008	0.012
C	0.10	0.14	0.25	0.004	0.005	0.010
D	1.80	2.00	2.20	0.070	0.078	0.086
E	1.15	1.25	1.35	0.045	0.049	0.053
e	0.65 BSC			0.026 BSC		
L	0.10	0.20	0.30	0.004	0.008	0.012
H _E	2.00	2.10	2.20	0.078	0.082	0.086

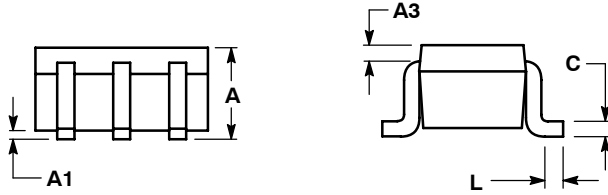

SOLDERING FOOTPRINT*

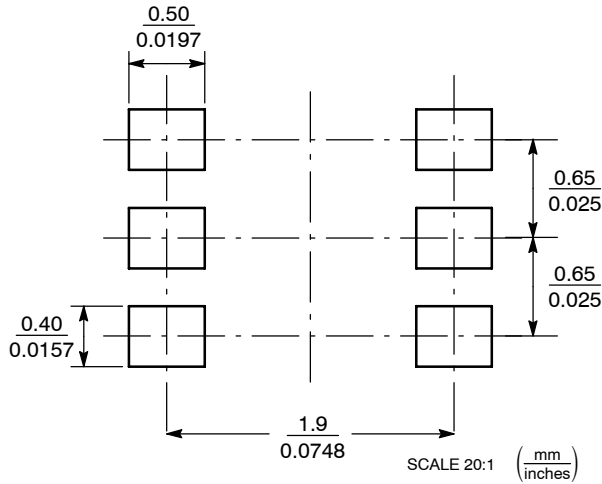

SC-88/SC70-6/SOT-363

*For additional information on our Pb-Free strategy and soldering details, please download the ON Semiconductor Soldering and Mounting Techniques Reference Manual, SOLDERRM/D.

NL7SZ19

查询"NL7SZ19_0"供应商

PACKAGE DIMENSIONS

UDFN6, 1.2x1.0, 0.4P
CASE 517AA-01
ISSUE A

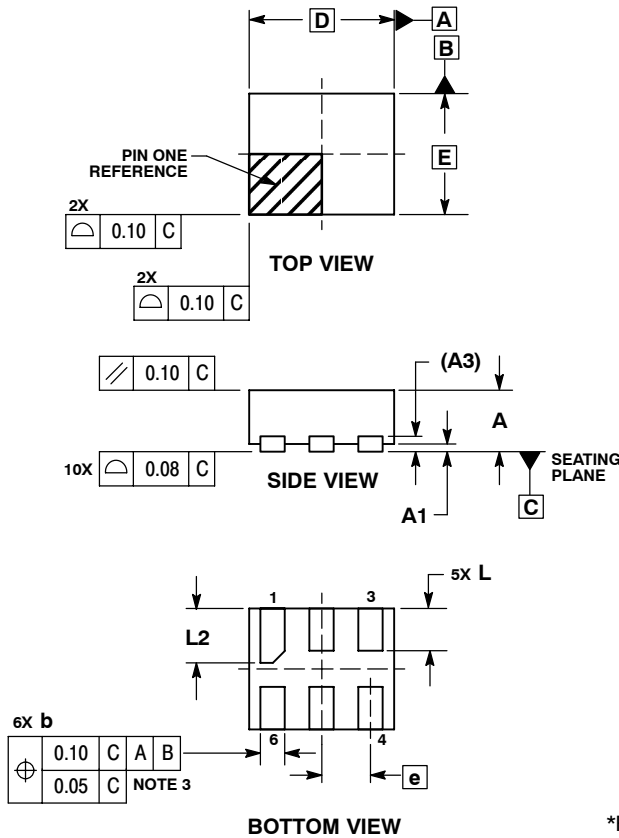

NOTES:

1. DIMENSIONING AND TOLERANCING PER ASME Y14.5M, 1994.
2. CONTROLLING DIMENSION: MILLIMETERS.
3. DIMENSION b APPLIES TO PLATED TERMINAL AND IS MEASURED BETWEEN 0.25 AND 0.30 mm FROM TERMINAL.
4. COPLANARITY APPLIES TO THE EXPOSED PAD AS WELL AS THE TERMINALS.

MILLIMETERS		
DIM	MIN	MAX
A	0.45	0.55
A1	0.00	0.05
A3	0.127	REF
b	0.15	0.25
D	1.00	BSC
E	1.20	BSC
e	0.40	BSC
L	0.30	0.40
L2	0.40	0.50

MOUNTING FOOTPRINT*

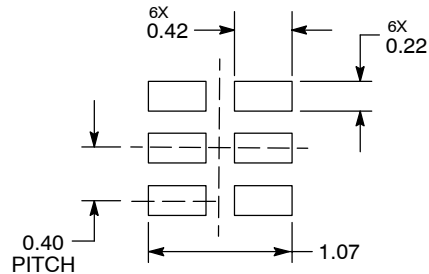

DIMENSIONS: MILLIMETERS

*For additional information on our Pb-Free strategy and soldering details, please download the ON Semiconductor Soldering and Mounting Techniques Reference Manual, SOLDERRM/D.

ON Semiconductor and are registered trademarks of Semiconductor Components Industries, LLC (SCILLC). SCILLC reserves the right to make changes without further notice to any products herein. SCILLC makes no warranty, representation or guarantee regarding the suitability of its products for any particular purpose, nor does SCILLC assume any liability arising out of the application or use of any product or circuit, and specifically disclaims any and all liability, including without limitation special, consequential or incidental damages. "Typical" parameters which may be provided in SCILLC data sheets and/or specifications can and do vary in different applications and actual performance may vary over time. All operating parameters, including "Typicals" must be validated for each customer application by customer's technical experts. SCILLC does not convey any license under its patent rights nor the rights of others. SCILLC products are not designed, intended, or authorized for use as components in systems intended for surgical implant into the body, or other applications intended to support or sustain life, or for any other application in which the failure of the SCILLC product could create a situation where personal injury or death may occur. Should Buyer purchase or use SCILLC products for any such unintended or unauthorized application, Buyer shall indemnify and hold SCILLC and its officers, employees, subsidiaries, affiliates, and distributors harmless against all claims, costs, damages, and expenses, and reasonable attorney fees arising out of, directly or indirectly, any claim of personal injury or death associated with such unintended or unauthorized use, even if such claim alleges that SCILLC was negligent regarding the design or manufacture of the part. SCILLC is an Equal Opportunity/Affirmative Action Employer. This literature is subject to all applicable copyright laws and is not for resale in any manner.

PUBLICATION ORDERING INFORMATION

LITERATURE FULFILLMENT:
Literature Distribution Center for ON Semiconductor
P.O. Box 5163, Denver, Colorado 80217 USA
Phone: 303-675-2175 or 800-344-3860 Toll Free USA/Canada
Fax: 303-675-2176 or 800-344-3867 Toll Free USA/Canada
Email: orderlit@onsemi.com

N. American Technical Support: 800-282-9855 Toll Free
USA/Canada
Europe, Middle East and Africa Technical Support:
Phone: 421 33 790 2910
Japan Customer Focus Center
Phone: 81-3-5773-3850

ON Semiconductor Website: www.onsemi.com
Order Literature: <http://www.onsemi.com/orderlit>

For additional information, please contact your local Sales Representative